

# **bluEvolution82** Planning manual





<b>Designation</b>	<b>Chapter</b>
Introduction	1
System features	2
Profile overview	3
Profile combinations	4
Window statics	5

---



Chapter 1

**Introduction**

---

**Designation**

**Page**

---

Introduction Planungshandbuch

1

---



**About this manual**

This manual contains important information and instructions for planning window and door elements with Salamander products. We present a wide range of applications and possible combinations. It is, however, not possible to show all applications. Please use our planning tool as a supplement or consult our technical customer service.

This manual has been prepared and checked with great care. However, errors cannot be excluded. We therefore kindly ask you to contact our technical customer service if you discover any errors or discrepancies.

This manual is an important part of the bluEvolution82 system kit.

- ▶ Always keep it within easy reach.

**Standards**

Most of the illustrations and drawings are not to scale. Scale illustrations are marked accordingly.

**Online**

This manual, test certificates and other technical documents are also available in electronic form in the login area of our website [salamander-windows.com](http://salamander-windows.com). Please note that the electronic documents may be more up to date than the printed versions.

**Further information**

Further information can be found in the log-in area of our website [salamander-windows.com](http://salamander-windows.com):

- Production manual
- Planning tool
- Statics calculator

We also recommend the following on the website [ift-rosenheim.de](http://ift-rosenheim.de):

- ift assembly planner

**Abbreviations**

RAM	Outer frame dimension
FAM	Outer sash dimension
FFM	Sash rebate dimension
B	Width
H	Height
L	Length
D	Thickness
AD	Stopper gasket, stopper gasket system
MD	Central gasket, central gasket system
DK	Tilt-turn
D-DK	Turn/tilt-turn
PSK	Parallel slide and tilt

**Symbols**

~	Dimensions are approximate
-----	Pattern film
— · —	Screwing axis
— · —	Line of symmetry
	Sealing compound

Pictograms

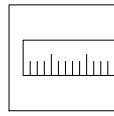

Measuring

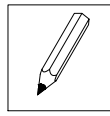

Marking

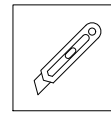

Cutting

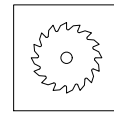

Sawing

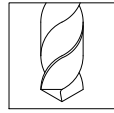

Drilling

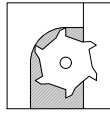

Shaping

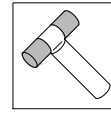

Tapping in with a recoilless soft-face hammer

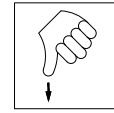

Pressing in

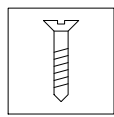

Screwing

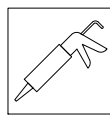

Sealing\*\*

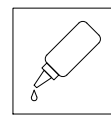

Gluing

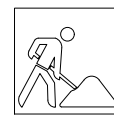

On the construction site

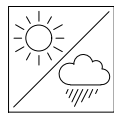

Outside

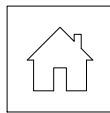

Room side

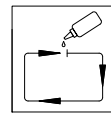

Inserting gasket, bonding joint

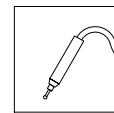

Shaping sealing groove

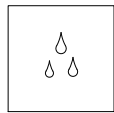

Condensation

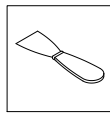

Sickle knife, spatula

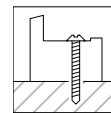

Dowel drilling

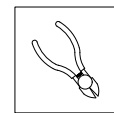

Removing with side cutters

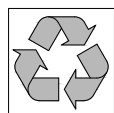

Profile with coloured recycled core

**i** INFO

\*\* Seal with permanently elastic, neutrally cross-linking sealing compound, suitable for PVC and galvanised steel.

Deviations noted separately.

---

<b>Standards and guidelines</b>	<p>Standards and guidelines specified in this manual and other applicable standards and directives:</p> <ul style="list-style-type: none"><li>▪ RAL-GZ 716</li><li>▪ DIN EN 12210</li><li>▪ DIN EN 12608</li><li>▪ DIN 16941-2A</li><li>▪ DIN 18055</li><li>▪ Eurocode 1</li><li>▪ DIN EN 14351-1</li><li>▪ Fastening of load-bearing hardware parts of turn and tilt-turn fittings (TBDK guideline)</li><li>▪ Technical guidelines of the glass trade</li><li>▪ Guideline for planning and executing the installation of windows and entrance doors</li></ul>
---------------------------------	--

**Disclaimer**

Our advice – whether verbal or written – is based on experience and provided to the best of our knowledge. However, no guarantee is given for the completeness or accuracy of the information contained in this manual. In particular, it does not contain any assurance of properties. We reserve the right to make technical changes. Working conditions beyond our control and different operating conditions exclude any claims based on our information. The user must check the suitability of selected products for the specific application on their own responsibility. The application, use and processing of the products are beyond our control and are therefore the sole responsibility of the user.

Statements require written confirmation from us to be legally valid.

Where products from other suppliers are shown in this manual, this is intended to illustrate possibilities. We accept no warranty or liability, to the extent permitted by law, for these representations or the specific use of third-party products that are not original Salamander products. Please check with the supplier before using it to make sure it's right for what you need.

Should liability on our part nevertheless arise, it shall be governed exclusively by our General Terms and Conditions valid at the time. They can be viewed, downloaded and printed at [salamander-windows.com/legal/terms-and-conditions](http://salamander-windows.com/legal/terms-and-conditions). Upon written request, we will also send them to you by post or email.

**Copyright**

The contents of this document are protected by copyright. The rights arising from this, in particular those of reprinting, extracting illustrations and translating, remain reserved.



## Chapter 2

**System features**

---

<b>Designation</b>	<b>Page</b>
System highlights	1
Design features	2
Element types	4
System-related dimensions	6
System-related dimensions of aluminium clip facing shells	8
Opening dimensions	9
Minimum breaking forces	10
Material characteristics	13

---



**System highlights**



- Combination system AD / MD
- Same faceplate profiles can be used for AD and MD
- Low view height possible
- Selected profiles available in Grade A and Grade B
- Fixed glazing possible without additional strips and machining steps

Technical specifications	
Heat transfer coefficient	0.97 W/(m <sup>2</sup> K)
Durability against wind loading	C5 / B5
Water tightness – unprotected	9A
Air permeability	Grade 4
Sound reduction	47 dB
Burglary inhibition	RC2 / RC3

Design features

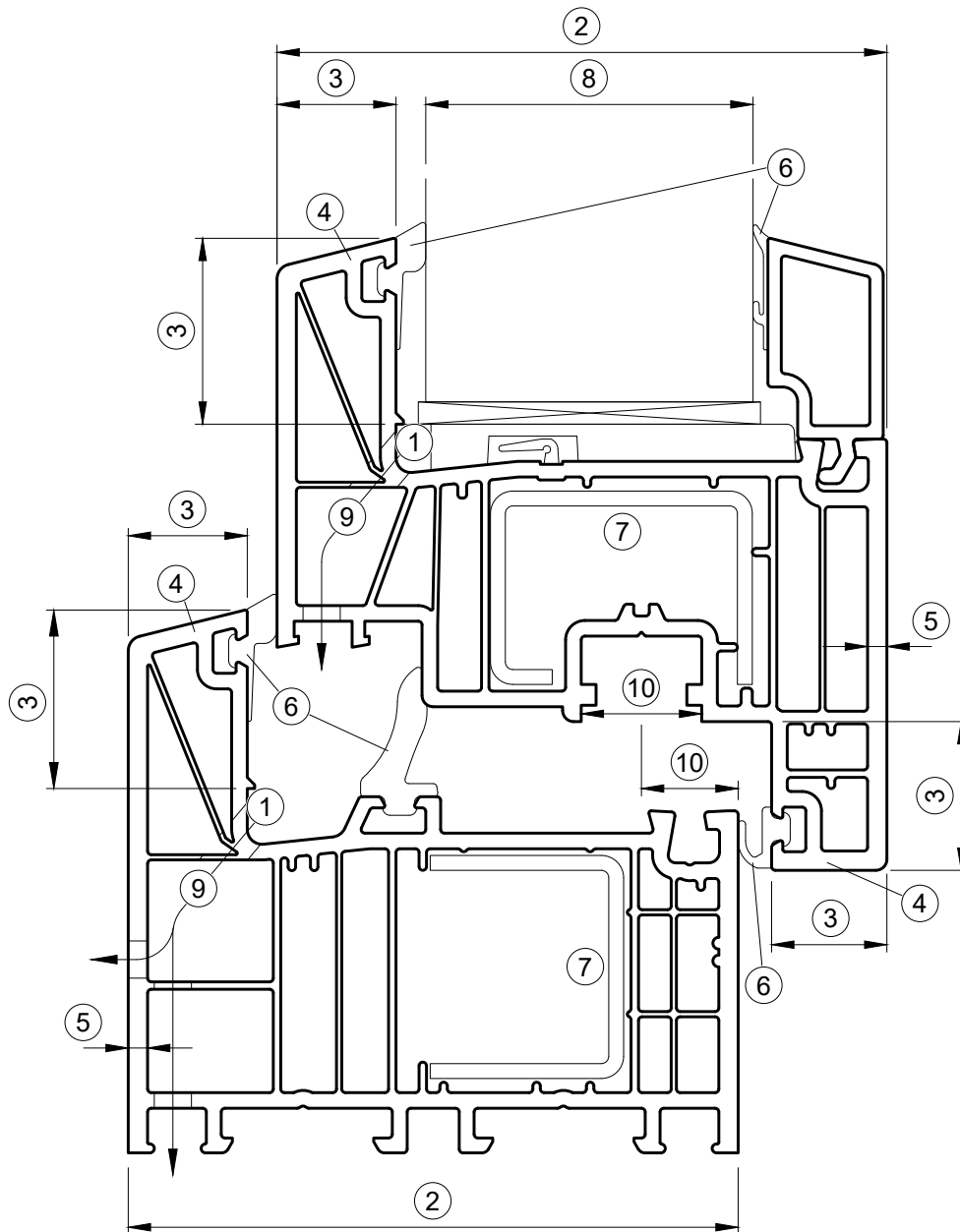

①	Rebate	Glazing rebate with water drainage channel and 3 mm upstand in frame and sash
②	Construction depth	Frame: 82 mm Sash: 82 mm Fixed mullion: 82 mm
③	Fittings	Stop height: outside 19 mm or 27 mm, inside 20 mm Stop width: outside 16 mm, inside 15.5 mm
④	Fitting shape	Outer stop bevelled at 14°, design versions available Interior sash stops straight Glazing-bead with 14° bevel Curve design version Design version box straight
⑤	Profile wall thickness	Outer walls of the main profiles according to RAL-GZ 716 Interior walls according to design requirements
⑥	Gaskets	Stopper gasket, inside and central gasket, glazing gasket ex-works, made of PVC-P, weldable Glazing-bead seal made of PVC-P Gap dimension of glazing 4 mm Gap dimension outer stop 4 mm, gap dimension inside stop 4.5 mm
⑦	Strengthening	Galvanised steel profiles according to RAL-GZ 716
⑧	Glazing	All commercially available insulating glass panes for thermal insulation, sound reduction and burglary inhibition. Infill thickness up to 52 mm
⑨	Drainage / ventilation	Via separate antechambers to the front or concealed downwards
⑩	Hardware	All commercially available single-handed hardware for 16 mm Euro-groove and 13 mm groove centre position
⑪	Profile connection	Frame and sash corner connection by butt welding Fixed mullions, deadbolts and glazing bars by mechanical connection, alternatively as V-weld
⑫	Chamber construction	6 chambers in frame and sash, 5 chambers in fixed mullion
⑬	Colours	White homogeneous in mass, through-dyed with long-life surface protection Standard foil décors outside and inside Special foil décors on request RAL coatings on request

**Model 1**

**1.1 Windows and French windows e.g. 1-sashed, 2-sashed, with fixed mullion**

Fixed glazed windows; turn-only windows, single-sashed, tilt&turn windows; bot-tom-hung windows; tilt-only windows; also multipart elements (according to DIN EN 14351-1).

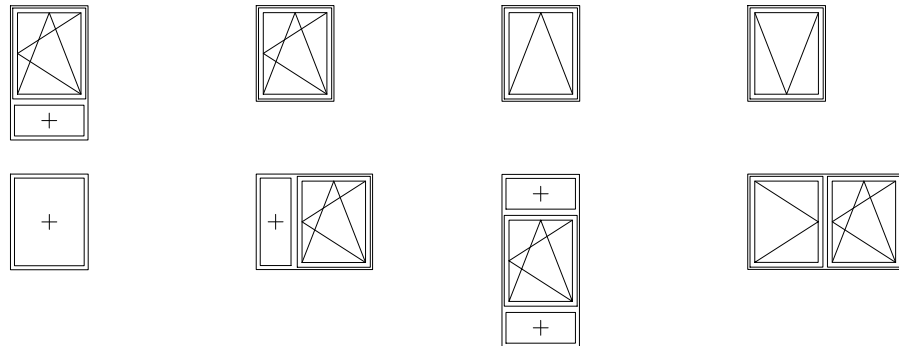

**1.2 Windows and French doors e.g. 2-sashed with loose fixed mullion (face-plate)**

Turn-only windows and doors, two- and multiple-sashed (opening inwards or out-wards), tilt&turn windows and French doors, also multipart (according to DIN EN 14351-1).

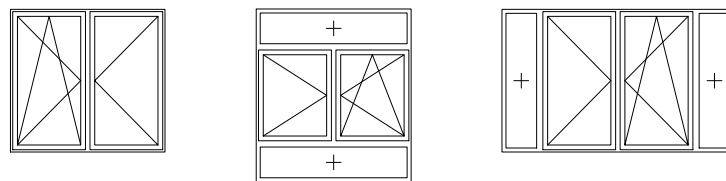

**Model 2**

**2.1 PSK doors and windows**

(parallel sliding and/or tilting or parking doors).

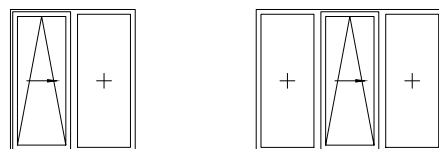

**2.2 Folding sliding windows and doors**

Folding sliding windows and doors (according to DIN EN 14351-1). Other opening types and combinations possible.

**Not currently possible.**

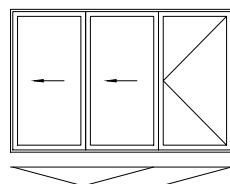

**2.3 Centre-pivot roof windows**

**Not currently possible.**

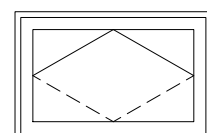

### 2.3 Miscellaneous (special) window designs

The determination of the performance characteristics varies depending on the type and requires special consideration with reference to product standard DIN EN 14351-1.

- Arched, segmental arch, basket arch windows
- Door constructions without thresholds, barrier-free elements
- Externally opening windows / French windows / front doors
- Fixed windows, gable windows (sloping elements)
- Triangular and trapezoidal windows single-sided and on both sides
- Arched windows, diamond windows, (e.g. in the gable)
- Other window designs

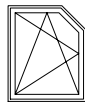

### Model 3

#### 3.1 Main doors

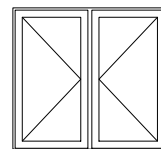
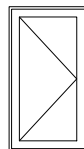
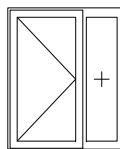

Transfer to tested sash sizes and the size tables stored in the system description, in compliance with the locking-points distances, similar format, compliance with the sash weight and consistent manufacturing quality.

### Window shapes

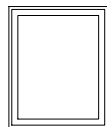

Rectangle



Triangle

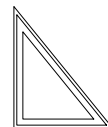

Slanted

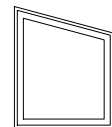

Slanted

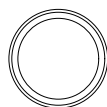

Round

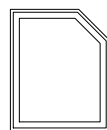

Polygon

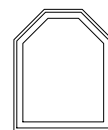

Polygon

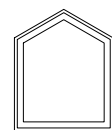

Polygon

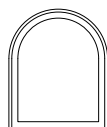

Round arch

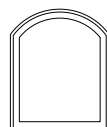

Segmental arch

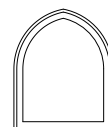

Pointed arch

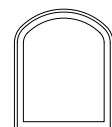

Basket arch

Frame  
HO9---, HP9---

Fixed mullion  
HO9---, HP9---

Sash  
HO8---, HP8---

MD system

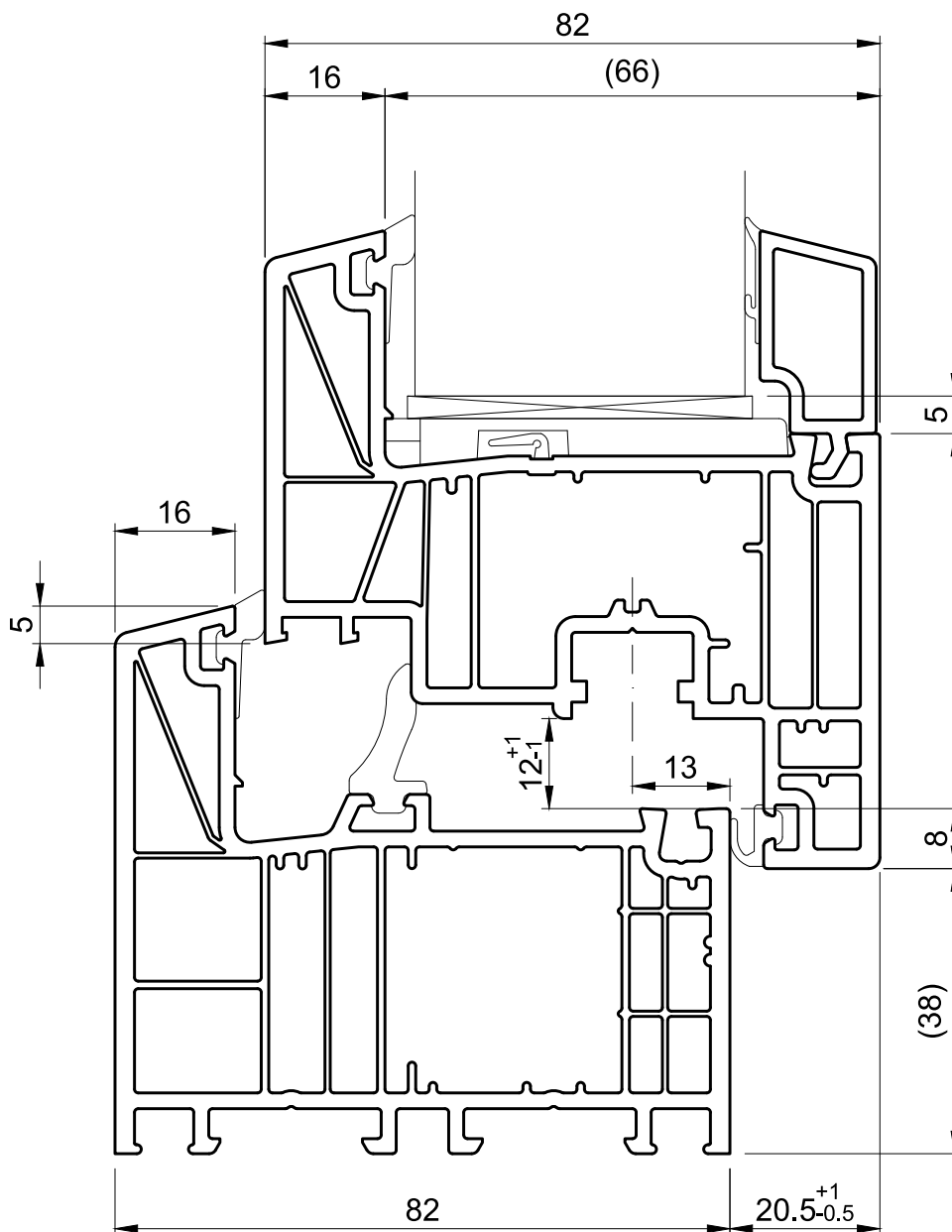

### Dimensional deviations

The dimensions listed below are approximate. Tolerances result from DIN 16941-2A, unless agreed separately.

The internal overlap depth in the bluEvolution82 system is  $20.5 +1/-0.5$  mm. Deviations from this nominal dimensional specification may result from tolerances in the profiles, seals and fittings used, as well as from the window manufacture itself.

The dimension of the overlap depth alone is not meaningful for the evaluation of the tightness of window elements; possible dimensional deviations therefore do not necessarily constitute a defect. Only technical test assessments and classifications in accordance with the applicable EN standards are authoritative for air and water tightness. The specification for permissible operating forces on window elements ( $\leq 10$  Nm) has priority over compliance with the overturning dimensions.

Frame  
HO8---, HP8---

Fixed mullion  
HO8---, HP8---

Sash  
HO8---, HP8---

AD system

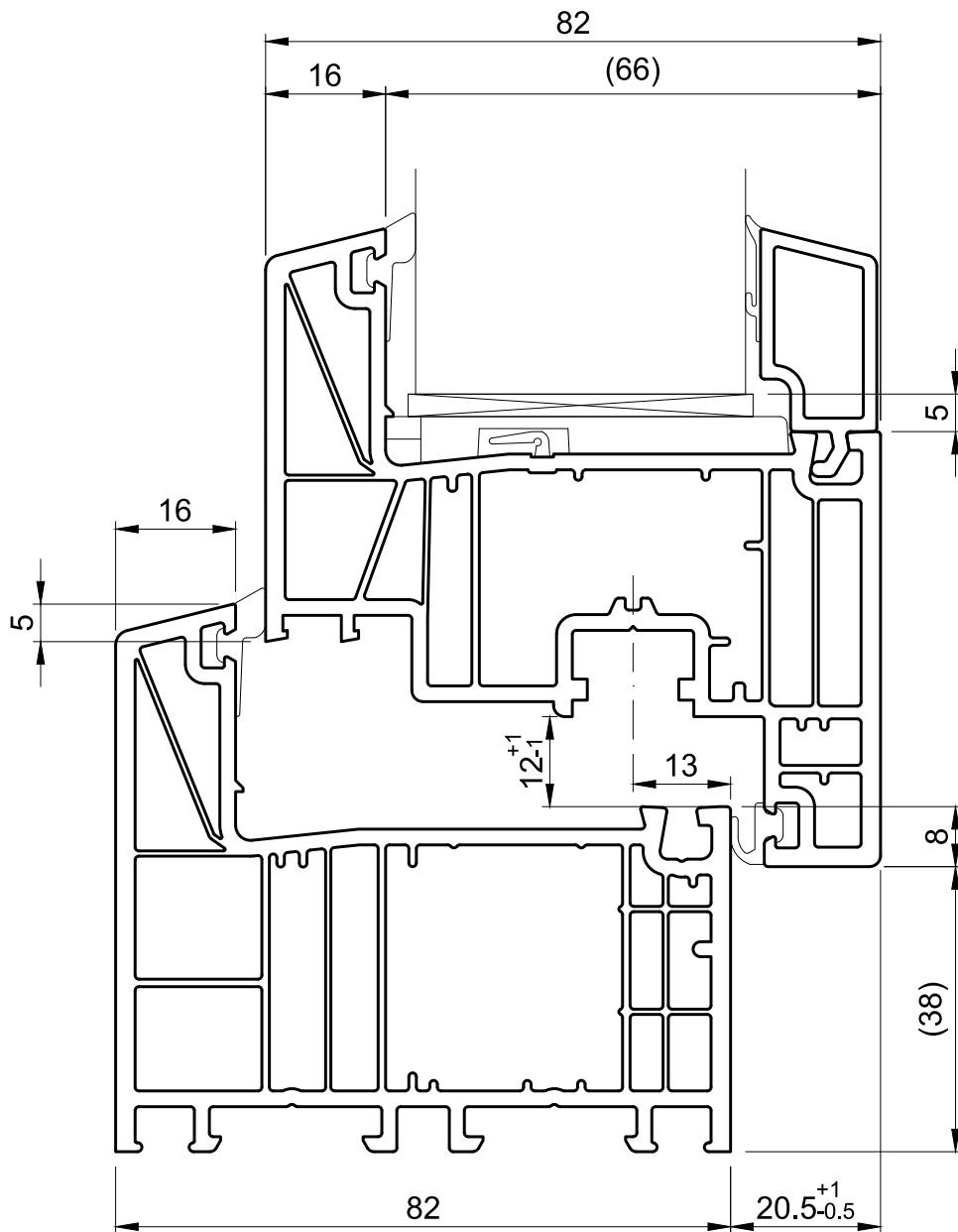

**Dimensional deviations**

The dimensions listed below are approximate. Tolerances result from DIN 16941-2A , unless agreed separately.

The internal overlap depth in the bluEvolution82 system is 20.5 +1/-0.5 mm. Deviations from this nominal dimensional specification may result from tolerances in the profiles, seals and fittings used, as well as from the window manufacture itself.

The dimension of the overlap depth alone is not meaningful for the evaluation of the tightness of window elements; possible dimensional deviations therefore do not necessarily constitute a defect. Only technical test assessments and classifications in accordance with the applicable EN standards are authoritative for air and water tightness. The specification for permissible operating forces on window elements ( $\leq 10$  Nm) has priority over compliance with the overturning dimensions.

Aluminium clip facing shells

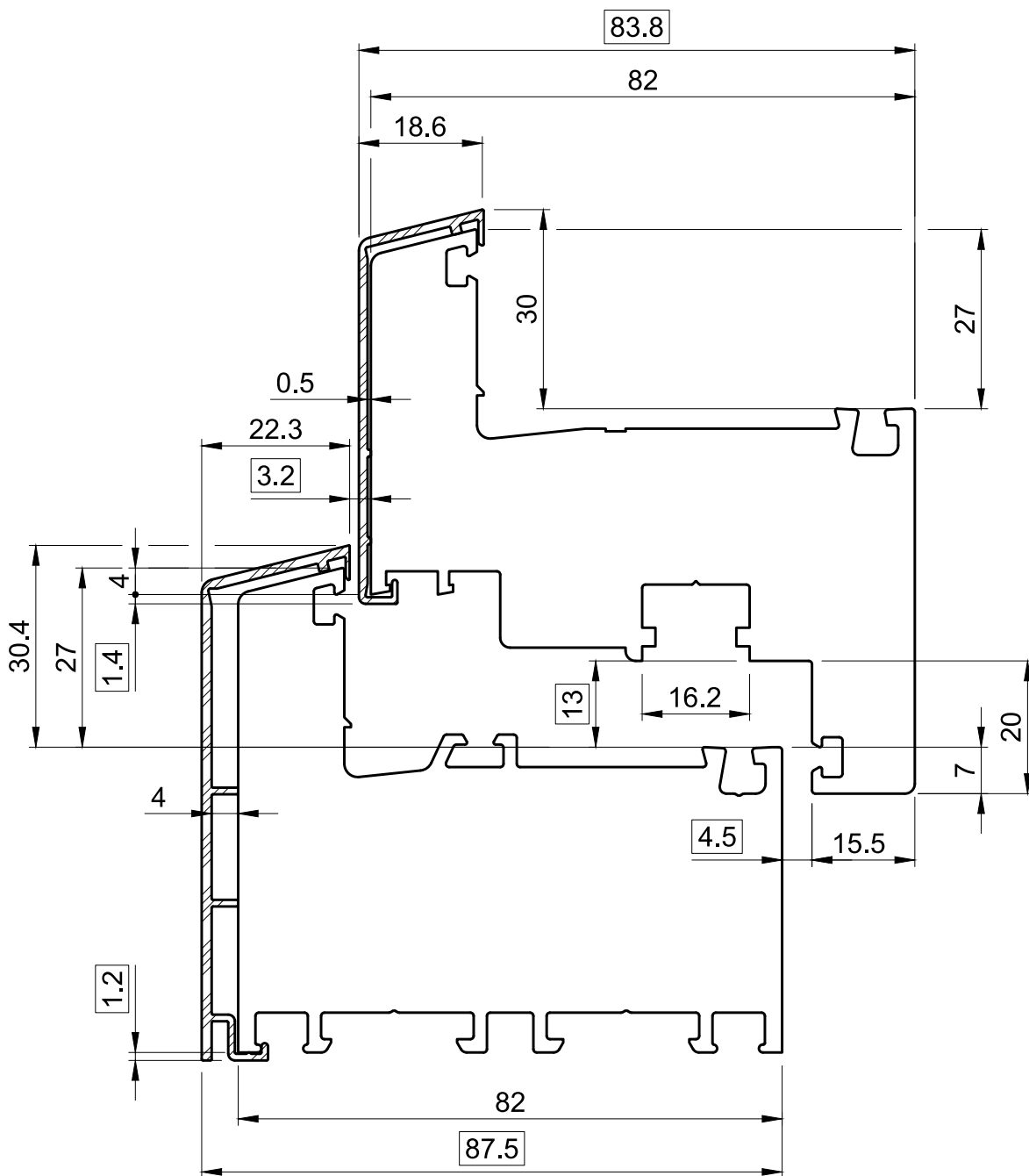

Frame  
HO9020 - HO9100

Sash  
HO8520

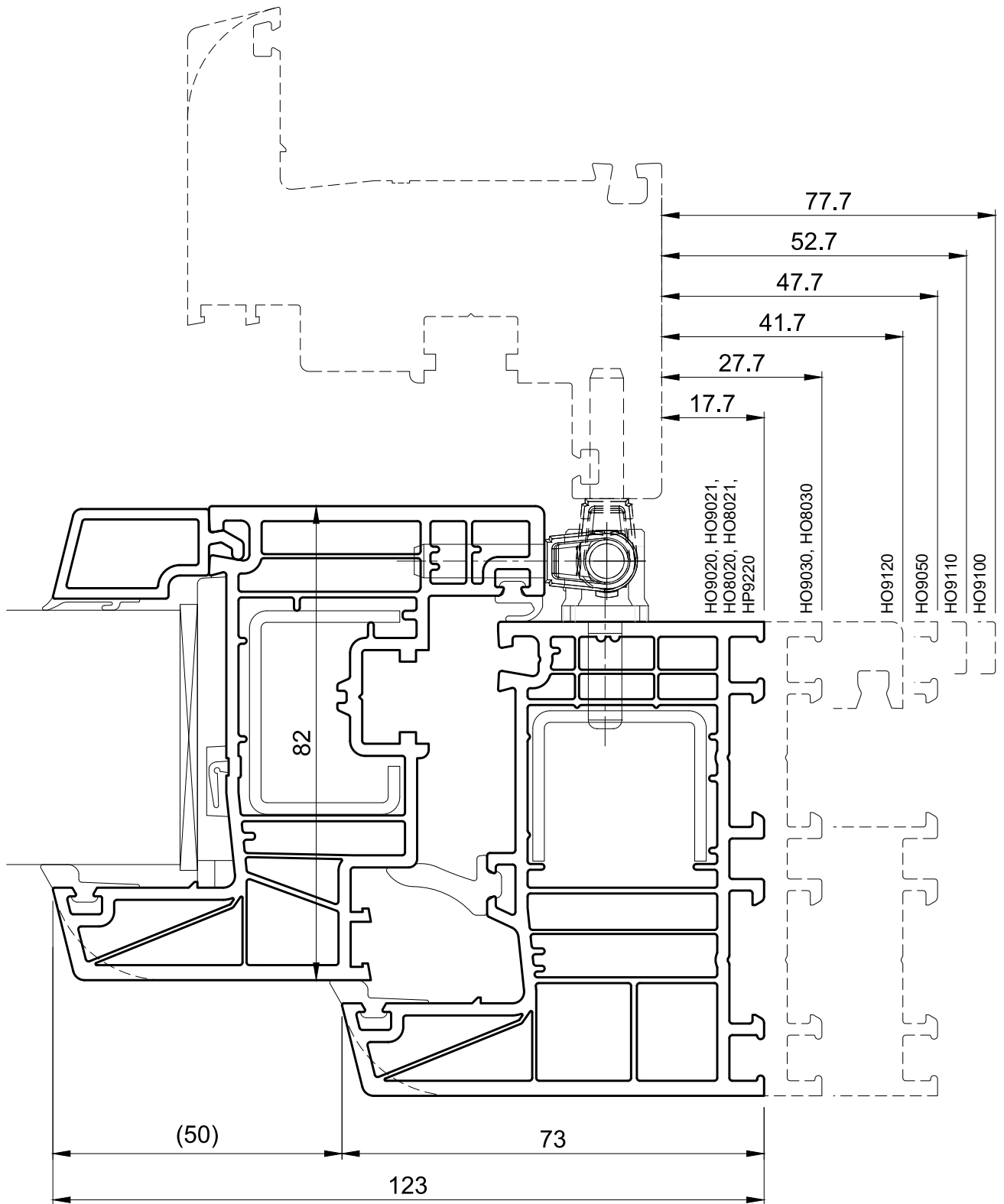

**Functional drawing**

Dimensions without tolerance specification according to quality assurance for PVC windows, RAL-GZ 716.

## Minimum breaking forces

**Weldability**

(Excerpt from RAL-GZ 716  
Technical Appendix;  
January 2023 edition)

The following applies for main profiles:

The weldability test is used to check the weldability of the formulation used.

During the pressure bending test on welded corner joints, at least the following stresses must be verified as fracture stress:

Individual value per sample  $\sigma_{\min \text{ individual}} = 30 \text{ N/mm}^2$

Average value from three samples  $\sigma_{\min \text{ average}} = 35 \text{ N/mm}^2$

The following applies as an exception: For a profile depth or overall width of  $\geq 100$  mm:  $\sigma_{\min \text{ individual}} = 24 \text{ N/mm}^2$ ,  $\sigma_{\min \text{ average}} = 28 \text{ N/mm}^2$

The maximum force  $F$  measured must not fall below the minimum breaking force  $F_c$  calculated using the equation below.

The minimum permissible individual value is calculated from the calculated minimum breaking force  $F_c$  for  $\sigma_{\min \text{ average}}$  by multiplying it by factor  $\left(\frac{30}{35}\right)$  or  $\left(\frac{24}{28}\right)$ , without taking the decimal place into account (cut off, do not round).

A test is considered passed if a measured force of  $F \geq 8000 \text{ N}$  is achieved.

	$F_c$	Calculated minimum breaking force in [N]
	$W$	Section modulus of the profile in direction of stress (inner corner) in [mm <sup>3</sup> ]
$F_c = \frac{2 \cdot W \cdot \sigma_{\min}}{a - \frac{e}{\sqrt{2}}}$	$\sigma_{\min}$	Minimum stress in [N/mm <sup>2</sup> ]
	$a$	Distance between rotation axes in [mm]; $a = (400 \pm 2) \text{ mm}$
	$e$	Distance of the critical fibre from the neutral fibre in [mm]

The calculated minimum breaking force  $F_c$  is specified by the profile manufacturer. Calculated minimum breaking forces  $\geq 8000 \text{ N}$  are for information purposes only.

To determine the cross-sectional area of the profile, the nominal external dimensions specified in the cross-sectional drawing filed with the quality association and the minimum wall thickness (lower tolerance) must be taken into account. For renovation frames (old building/slip-on frames) with a wide overlap (for profile or wall covering), this overlap is not taken into account when calculating the minimum breaking force.

Minimum breaking forces

**Calculated minimum breaking forces**

Art. no.	La (mm)	Cut (mm)	100% - unplastered corners		80% - plastered corners	
			F <sub>c</sub> Average value (N)	F <sub>c</sub> Individual value (N)	F <sub>c</sub> Average value (N)	F <sub>c</sub> Individual value (N)
HO8020	341	344	3712	3182	2970	2545
HO8021	341	344	3712	3182	2970	2545
HO8030	351	354	5075	4350	4060	3480
HO8300	361	364	2920	2502	2336	2002
HO8310	359	362	5107	4377	4085	3501
HO8320	379	382	5137	4403	4110	3522
HO8510	351	354	2662	2281	2130	1825
HO8520	364	367	4053	3473	3242	2779
HO8521	364	367	4053	3473	3242	2779
HO8530	392	395	7116	6099	5693	4879
HO8540	392	395	7097	6083	5678	4866
HO8570	337	340	2453	2102	1962	1681
HO8580	393	396	8997*	7711	7197	6169
HO9020	342	345	3808	3263	3046	2611
HO9021	342	345	3808	3263	3046	2611
HO9030	352	355	5217	4471	4174	3577
HO9050	372	375	7004	6003	5603	4802
HO9100	342	345	3831	3283	3065	2627
HO9110	342	345	3831	3283	3065	2627
HO9120	332	335	2454	2103	1963	1682
HO9310	379	382	5299	4542	4239	3633
HO9320	379	382	5330	4568	4264	3654
HO9330	399	402	7007	6005	5606	4804
HO9340	399	402	7085	6072	5668	4858
HP8550	406	409	10735*	9201*	8588*	7361
HP8560	407	410	10661*	9138*	8529*	7310
HP8920	362	365	4040	3463	3232	2770
HP8930	391	394	7381	6326	5905	5061
HP9020	342	345	4128	3538	3302	2830
HP9220	340	343	3795	3253	3036	2602
HP9420	379	382	5130	4396	4104	3517

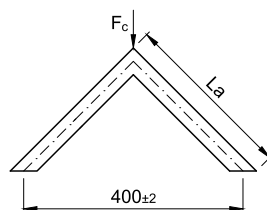

F<sub>c</sub> Calculated minimum breaking force in [N]

La Length of the profile-pieces on the outside

\* A test is considered passed if a measured force of F ≥ 8000 N is achieved.

## Minimum breaking forces Greta

**Greta**

Greta is produced from 100 % recycled PVC. Due to the varying composition of the recyclate, it is not always possible to achieve a consistent homogeneity of the recycled material.

For this reason, the permissible minimum breaking stress for profiles made of Greta material has been reduced.

SIP recommends regularly checking the minimum breaking forces of the frames and sash-frames required in the currently valid processing guidelines and adjusting the welding parameters if necessary. Depending on the welding machine used, the optimum welding parameters for profiles made of Greta material should be determined in advance through a series of tests.

The best welding results were achieved with welding machines that use the parallel thrust welding procedure. The optimum welding temperature here was  $245 \pm 5^\circ\text{C}$ . With welding machines that use the diagonal thrust welding procedure, the corner strength values can be lower, as with white profiles.

**Calculated minimum breaking forces Greta**

Art. no.	La (mm)	Cut (mm)	100% - unplastered corners		80% - plastered corners	
			F <sub>c</sub> Average value (N)	F <sub>c</sub> Individual value (N)	F <sub>c</sub> Average value (N)	F <sub>c</sub> Individual value (N)
HO8030	351	354	3248	2784	2599	2227
HO8300	361	364	1869	1601	1495	1281
HO8510	351	354	1704	1460	1363	1168
HO8520	364	367	2594	2223	2075	1778
HO8521	364	367	2594	2223	2075	1778
HO8530	392	395	4554	3903	3643	3122
HO8540	392	395	4542	3893	3634	3114
HO9020	342	345	2437	2088	1950	1671
HO9021	342	345	2437	2088	1950	1671
HO9030	352	355	3339	2862	2671	2289
HO9100	342	345	2452	2101	1961	1681
HO9110	342	345	2452	2101	1961	1681
HO9320	379	382	3411	2923	2729	2339
HO9330	399	402	4484	3843	3588	3075
HO9340	399	402	4534	3886	3627	3109
HP8550	406	409	6871	5889	5496	4711

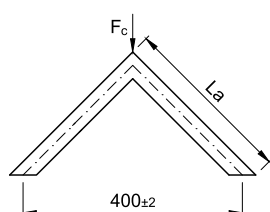

F<sub>c</sub> Calculated minimum breaking force in [N]

L<sub>a</sub> Length of the profile-pieces on the outside

\* A test is considered passed if a measured force of  $F \geq 8000$  N is achieved.

**Profile material**

SALAMANDER plastic window profiles are made of high-impact modified rigid PVC in accordance with the RAL quality and testing regulations for plastic window profiles RAL-GZ 716.

Moulding compound:

Through-dyed rigid PVC moulding compound in white, cream, caramel, brown and anthracite.

Designation according to EN ISO 1163-1:

Moulding compound ISO 1163-PVC-U, EDLP, 082-25-28

PVC = Polyvinyl chloride

D = Powder

U = Hard (plasticiser-free)

L = Light and weather resistant stabilized (White and cream. Caramel, brown and anthracite only available with decorative film).

E = Extrusion

P = Impact modified

SALAMANDER moulding compound exceeds the requirements of RAL-GZ 716.

PVC type		Delivery form		Processing	
Letter	Meaning	Letter	Meaning	Letter	Meaning
U	Free of plasticisers	D	Powder	E	Extrusion
Vicat softening temperature VST/B		Min. notched impact strength		Min. bending modulus of elasticity	
Digit	°C	Digit	kJ/m <sup>2</sup>	Digit	N/mm <sup>2</sup>
082	>80 ≤84	25	>20	28	>2500

Testing on press plates

**Window profiles**

Measurement on test pieces made of extruded profiles: (removed in extrusion direction)

	Test method	Unit	Value
Density	EN ISO 1183 - 1	g/cm <sup>3</sup>	1.44 ±0.03
Thermostability	EN ISO 182 - 2	min	>30
Vicat softening temperature VST/B	EN ISO 306	°C	80-83 °C
Coefficient of linear expansion between -30 °C and +50 °C	Leitz dilatometer	K <sup>1</sup>	8x10 <sup>-5</sup>
Thermal conductivity	EN ISO 10077 - 1	W/(m·K)	0.17
Fire behaviour	EN 13501 - 1		Class E
Resistance to artificial weathering	EN 513	GJ/m <sup>2</sup>	12, ΔE <3.8
Tensile modulus of elasticity	EN ISO 527	N/mm <sup>2</sup>	>2500 ±300
Notched impact strength at +23 °C	EN ISO 179-1/fA	kJ/m <sup>2</sup>	>55 (wall thickness A) >60 (wall thickness B)
Impact strength	EN ISO 8256	kJ/m <sup>2</sup>	>500 (23 °C)

**Gaskets, PVC-P**

PVC-P quality according to RAL-GZ 716, section II; product class IV (exterior and interior)

	Test method	Unit	Value
Density	EN ISO 1183-1	g/cm <sup>3</sup>	1.22 ±0.03
Tensile strength	DIN 53 504	N/mm <sup>2</sup>	≥5.0
Elongation at break	DIN 53 504	%	≥250
Compression set (-25 °C / 22 h / 25 %)	DIN ISO 815	%	≤90
(23 °C / 22 h / 25 %)		%	≤35
(70 °C / 22 h / 25 %)		%	≤50
Behaviour after heat ageing	DIN 53 508 (7 days, 100 °C)		No complaints
Change in hardness	DIN ISO 48	IRHD	≤5
Change in tensile strength	DIN 53 504/53 455	%	≤25
Elongation at break (absolute)	DIN 53 504/53 455	%	≥200
Change in Shore hardness with temperature change from 23 °C to -10 °C	DIN 53 505	-	≤25
Behaviour after exposure to ozone	DIN 53 509	Crack level	0
Weatherfastness	ISO 188	GMA02	≥3 no cracks, blisters
Weather resistance	ISO 105 A	%	≥200
Contact discolouration	ISO 3865	GMA02	≥4
Weight loss	DIN 53407, Method A	%	≤3.0
Compatibility	Contact under tensile bending stress of 0-15 N/mm <sup>2</sup>		No cracking in the contact material

**Gaskets, EPDM**

Quality in accordance with DIN 7863 or RAL-GZ 716, section II; elastomer class A

	Test method	Unit	Value	Value
Nominal hardness		IRHD	≤50	>50 / ≤70
Density	DIN 53479, procedure A	g/cm <sup>3</sup>		
Tolerance of nominal hardness	DIN 53 519	IRHD	±5	±5
Tensile test	DIN 53 504			
Tensile strength		N/mm <sup>2</sup>	≥7.5	≥7.5
Elongation at break		%	≥300	≥200
Compression set (-25 °C / 22 h / 25 %)	DIN ISO 815	%	≤70	≤80
(23 °C / 22 h / 25 %)				
(100 °C / 22 h / 25 %)				
Behaviour after heat ageing	DIN 53 508 (7 days, 100 °C)		No complaints	
Change in hardness	DIN 53 519	IRHD	≤15	≤15
Change in tensile strength	DIN 53 504	%	≤25	≤25
Elongation at break (absolute)	DIN 53 504	%	≥200	≥150
Change in Shore hardness with temperature change from 23 °C to -10 °C	DIN 53 505	Shore A	≤10	≤10
Behaviour after exposure to ozone	DIN 53 509	Crack level	0	0
Behaviour under artificial weathering	RAL-GZ 716, Section I		no cracks, blisters	
Weather resistance	DIN 53504 (elongation at break)	%	≥200	≥150
Contact discolouration	DIN 53 540	Fastness number (A02)	≥3	≥3
			Fastness number (A03)	≥4
Weight loss	EN ISO 176 method A	%	≤3.0	≤3.0
Compatibility	Contact under tensile bending stress of 0 - 15 N/mm <sup>2</sup>		No cracking in the contact material	



## Chapter 3

**Profile overview**

<b>Designation</b>	<b>Page</b>
Parts list	1
Frame	43
Sash	54
Post, mullion	64
Faceplate, right-angled profiles	72
Glazing-beads	78
Gaskets	87
Glass rebate bridges, glass blocks	92
Strengthening	93
Weldable corner connector	102
Fixed-mullion connector, glazing bar connector	103
Faceplate end cover caps	106
Door thresholds	110
Widenings	122
Sill connection	130
Window sill	133
Couplings	134
Static couplings	135
Corner connections	136
Static profiles (pilaster strips)	139
Fixing	141
Glazing bars, self-adhesive	143
Weather profile strip	144
Cladding profiles	145
Roller shutter accessories	152
Panels	157

Chapter 3

**Profile overview**

---

Drilling and cutting jigs 158

---

Miscellaneous accessories 162

---

Aluminium clip facing shells 164

---

Main profiles

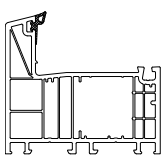
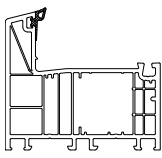
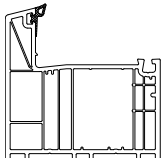
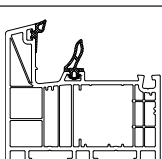
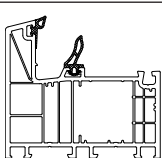
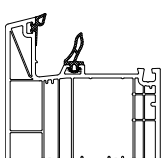
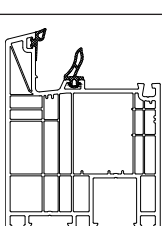
Colour base body: PW = pureWhite; CA = caramel; BR = brown; AN = anthracite, CR = cream; GL = Greta@Fenster_loop SW = solidWhite Colour seal: s = black; g = grey; l = light grey (suitable with Greta@Fenster_loop) Décor: <input type="checkbox"/> = without <input type="checkbox"/> = on both sides <input type="checkbox"/> = outside <input type="checkbox"/> = inside						
Illustration	Description	Article no.	Length / PU	Colour main body+colour gasket	Pattern	From page
<b>Frame</b>						
	Frame	<b>HO8020</b>	6.5 m	SW+s; SW+g; BR+s; CA+s; AN+s	<input type="checkbox"/>   <input type="checkbox"/> <input type="checkbox"/> <input type="checkbox"/>	<a href="#">Chapter 3</a> <a href="#">Page 45</a>
	Frame	<b>HO8021</b>	6.5 m	SW+s; SW+g; BR+s; CA+s; AN+s	<input type="checkbox"/>   <input type="checkbox"/> <input type="checkbox"/> <input type="checkbox"/>	<a href="#">Chapter 3</a> <a href="#">Page 46</a>
	Frame	<b>HO8030</b>	6.5 m	SW+s; SW+g; BR+s; CA+s; AN+s; GL+l	<input type="checkbox"/>   <input type="checkbox"/> <input type="checkbox"/> <input type="checkbox"/>	<a href="#">Chapter 3</a> <a href="#">Page 49</a>
	Frame	<b>HO9020</b>	6.5 m	SW+s; SW+g; BR+s; CA+s; AN+s	<input type="checkbox"/>   <input type="checkbox"/> <input type="checkbox"/> <input type="checkbox"/>	<a href="#">Chapter 3</a> <a href="#">Page 43</a>
	Frame	<b>HO9021</b>	6.5 m	SW+s; SW+g; BR+s; CA+s; AN+s; GL+l	<input type="checkbox"/>   <input type="checkbox"/> <input type="checkbox"/> <input type="checkbox"/>	<a href="#">Chapter 3</a> <a href="#">Page 44</a>
	Frame	<b>HO9030</b>	6.5 m	SW+s; SW+g; BR+s; CA+s; AN+s; GL+l	<input type="checkbox"/>   <input type="checkbox"/> <input type="checkbox"/> <input type="checkbox"/>	<a href="#">Chapter 3</a> <a href="#">Page 47</a>
	Frame	<b>HO9050</b>	6.5 m	SW+s; SW+g; BR+s; CA+s; AN+s	<input type="checkbox"/>   <input type="checkbox"/> <input type="checkbox"/>	<a href="#">Chapter 3</a> <a href="#">Page 50</a>

Main profiles

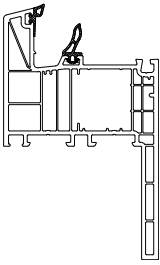
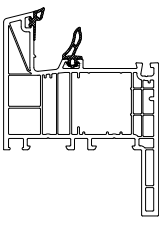
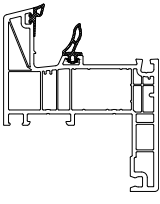
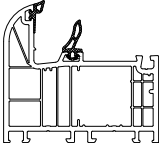
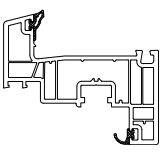
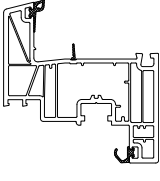
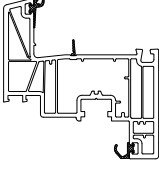
Colour base body: PW = pureWhite; CA = caramel; BR = brown; AN = anthracite, CR = cream; GL = Greta@Fenster_loop SW = solidWhite Colour seal: s = black; g = grey; l = light grey (suitable with Greta@Fenster_loop) Décor: <input type="checkbox"/> = without <input type="checkbox"/> = on both sides <input type="checkbox"/> = outside <input type="checkbox"/> = inside						
Illustration	Description	Article no.	Length / PU	Colour main body+colour gasket	Pattern	From page
	Frame	<b>HO9100</b>	6.5 m	SW+s; SW+g; BR+s; CA+s; AN+s	<input type="checkbox"/> <input type="checkbox"/> <input type="checkbox"/> <input type="checkbox"/>	<a href="#">Chapter 3</a> <a href="#">Page 53</a>
	Frame	<b>HO9110</b>	6.5 m	SW+s; SW+g; BR+s; CA+s; AN+s; GL+l	<input type="checkbox"/> <input type="checkbox"/> <input type="checkbox"/> <input type="checkbox"/>	<a href="#">Chapter 3</a> <a href="#">Page 51</a>
	Frame	<b>HO9120</b>	6.5 m	SW+s; SW+g; BR+s; CA+s; AN+s	<input type="checkbox"/> <input type="checkbox"/> <input type="checkbox"/> <input type="checkbox"/>	<a href="#">Chapter 3</a> <a href="#">Page 52</a>
	Frame	<b>HP9220</b>	6.5 m	SW+s; SW+g; BR+s; CA+s; AN+s	<input type="checkbox"/> <input type="checkbox"/> <input type="checkbox"/> <input type="checkbox"/> <input type="checkbox"/>	<a href="#">Chapter 3</a> <a href="#">Page 48</a>
<b>Sash</b>						
	Sash	<b>HO8510</b>	6.5 m	SW+s; SW+g; BR+s; CA+s; AN+s; GL+l	<input type="checkbox"/> <input type="checkbox"/> <input type="checkbox"/> <input type="checkbox"/>	<a href="#">Chapter 3</a> <a href="#">Page 54</a>
	Sash	<b>HO8520</b>	6.5 m	SW+s; SW+g; BR+s; CA+s; AN+s	<input type="checkbox"/> <input type="checkbox"/> <input type="checkbox"/> <input type="checkbox"/> <input type="checkbox"/>	<a href="#">Chapter 3</a> <a href="#">Page 55</a>
	Sash	<b>HO8521</b>	6.5 m	SW+s; SW+g; BR+s; CA+s; AN+s; GL+l	<input type="checkbox"/> <input type="checkbox"/> <input type="checkbox"/> <input type="checkbox"/> <input type="checkbox"/>	<a href="#">Chapter 3</a> <a href="#">Page 56</a>

Main profiles

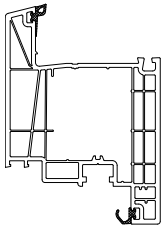
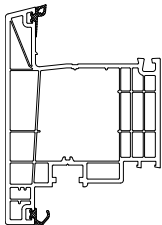
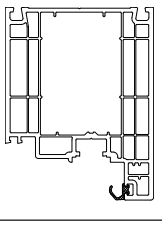
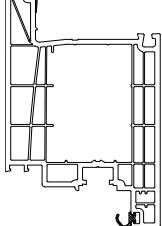
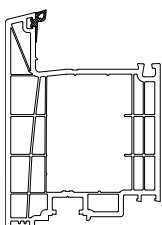
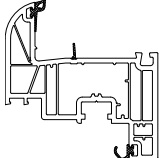
Colour base body: PW = pureWhite; CA = caramel; BR = brown; AN = anthracite, CR = cream; GL = Greta@Fenster_loop SW = solidWhite Colour seal: s = black; g = grey; l = light grey (suitable with Greta@Fenster_loop) Décor: <input type="checkbox"/> = without <input type="checkbox"/> = on both sides <input type="checkbox"/> = outside <input type="checkbox"/> = inside						
Illustration	Description	Article no.	Length / PU	Colour main body+colour gasket	Pattern	From page
	Sash	<b>HO8530</b>	6.5 m	SW+s; SW+g; BR+s; CA+s; AN+s; GL+l	<input type="checkbox"/>   <input type="checkbox"/>   <input type="checkbox"/>	<a href="#">Chapter 3</a> <a href="#">Page 58</a>
	Sash	<b>HO8540</b>	6.5 m	SW+s; SW+g; BR+s; CA+s; AN+s; GL+l	<input type="checkbox"/>   <input type="checkbox"/>   <input type="checkbox"/>	<a href="#">Chapter 3</a> <a href="#">Page 59</a>
	Sash	<b>HO8580</b>	6.5 m	SW+s; SW+g; BR+s; CA+s; AN+s	-	<a href="#">Chapter 3</a> <a href="#">Page 63</a>
	Sash	<b>HP8550</b>	6.5 m	SW+s; SW+g; BR+s; CA+s; AN+s; GL+l	<input type="checkbox"/>   <input type="checkbox"/>   <input type="checkbox"/>	<a href="#">Chapter 3</a> <a href="#">Page 61</a>
	Sash	<b>HP8560</b>	6.5 m	SW+s; SW+g; BR+s; CA+s; AN+s	<input type="checkbox"/>   <input type="checkbox"/>   <input type="checkbox"/>	<a href="#">Chapter 3</a> <a href="#">Page 62</a>
	Sash	<b>HP8920</b>	6.5 m	SW+s; SW+g; BR+s; CA+s; AN+s	<input type="checkbox"/>   <input type="checkbox"/>   <input type="checkbox"/>	<a href="#">Chapter 3</a> <a href="#">Page 57</a>

## Main profiles

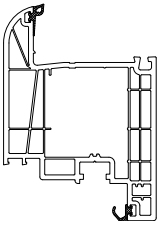
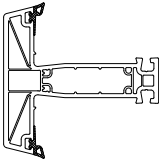
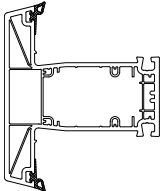
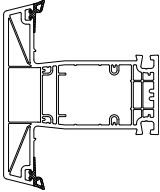
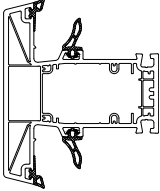
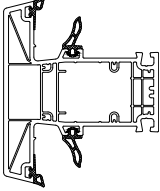
Colour base body: PW = pureWhite; CA = caramel; BR = brown; AN = anthracite, CR = cream; GL = Greta@Fenster_loop SW = solidWhite Colour seal: s = black; g = grey; l = light grey (suitable with Greta@Fenster_loop) Décor: <input type="checkbox"/> = without <input type="checkbox"/> = on both sides <input type="checkbox"/> = outside <input type="checkbox"/> = inside						
Illustration	Description	Article no.	Length / PU	Colour main body+colour gasket	Pattern	From page
	Sash	<b>HP8930</b>	6.5 m	SW+s; SW+g; BR+s; CA+s; AN+s	<input type="checkbox"/>   <input type="checkbox"/> <input type="checkbox"/>	<a href="#">Chapter 3</a> <a href="#">Page 60</a>
<b>Fixed mullion / glazing bar</b>						
	Glazing bar	<b>HO8300</b>	6.5 m	SW+s; SW+g; BR+s; CA+s	-	<a href="#">Chapter 3</a> <a href="#">Page 71</a>
	Fixed mullion	<b>HO8310</b>	6.5 m	PW+s; PW+g; SW+s; SW+g; BR+s; CA+s; AN+s	<input type="checkbox"/>   <input type="checkbox"/> <input type="checkbox"/> <input type="checkbox"/>	<a href="#">Chapter 3</a> <a href="#">Page 69</a>
	Fixed mullion	<b>HO8320</b>	6.5 m	PW+s; PW+g; SW+s; SW+g; BR+s; CA+s; AN+s	<input type="checkbox"/>   <input type="checkbox"/> <input type="checkbox"/> <input type="checkbox"/>	<a href="#">Chapter 3</a> <a href="#">Page 70</a>
	Fixed mullion	<b>HO9310</b>	6.5 m	SW+s; SW+g; BR+s; CA+s; AN+s	<input type="checkbox"/>   <input type="checkbox"/> <input type="checkbox"/>	<a href="#">Chapter 3</a> <a href="#">Page 64</a>
	Fixed mullion	<b>HO9320</b>	6.5 m	SW+s; SW+g; BR+s; CA+s; AN+s; GL+l	<input type="checkbox"/>   <input type="checkbox"/> <input type="checkbox"/> <input type="checkbox"/>	<a href="#">Chapter 3</a> <a href="#">Page 65</a>

Main profiles

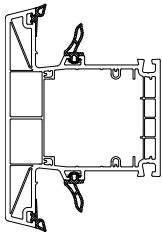
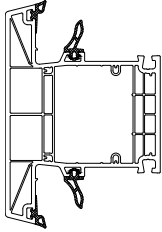
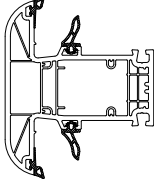
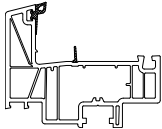
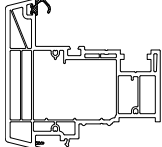
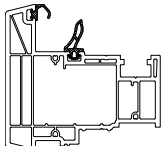
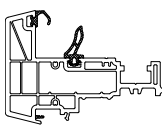
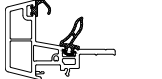
Colour base body: PW = pureWhite; CA = caramel; BR = brown; AN = anthracite, CR = cream; GL = Greta@Fenster_loop SW = solidWhite Colour seal: s = black; g = grey; l = light grey (suitable with Greta@Fenster_loop) Décor: <input type="checkbox"/> = without <input type="checkbox"/> = on both sides <input type="checkbox"/> = outside <input type="checkbox"/> = inside						
Illustration	Description	Article no.	Length / PU	Colour main body+colour gasket	Pattern	From page
	Fixed mullion	<b>HO9330</b>	6.5 m	SW+s; SW+g; BR+s; CA+s; AN+s; GL+l	<input type="checkbox"/>   <input type="checkbox"/> <input type="checkbox"/>	<a href="#">Chapter 3</a> <a href="#">Page 66</a>
	Fixed mullion	<b>HO9340</b>	6.5 m	SW+s; SW+g; BR+s; CA+s; AN+s; GL+l	<input type="checkbox"/>   <input type="checkbox"/> <input type="checkbox"/>	<a href="#">Chapter 3</a> <a href="#">Page 67</a>
	Fixed mullion	<b>HP9420</b>	6.5 m	SW+s; SW+g; BR+s; CA+s; AN+s	<input type="checkbox"/>   <input type="checkbox"/> <input type="checkbox"/>	<a href="#">Chapter 3</a> <a href="#">Page 68</a>
<b>Right-angled profiles</b>						
	French window sash	<b>HO8570</b>	6.5 m	SW+g; AN+s	<input type="checkbox"/>   <input type="checkbox"/>	<a href="#">Chapter 3</a> <a href="#">Page 73</a>
	Right-angled profile	<b>HO8800</b>	6.5 m	SW+s; SW+g; BR+s; CA+s; AN+s	<input type="checkbox"/>   <input type="checkbox"/> <input type="checkbox"/> <input type="checkbox"/>	<a href="#">Chapter 3</a> <a href="#">Page 77</a>
	Right-angled profile	<b>HO9800</b>	6.5 m	SW+s; SW+g; BR+s; CA+s; AN+s; GL+l	<input type="checkbox"/>   <input type="checkbox"/> <input type="checkbox"/> <input type="checkbox"/>	<a href="#">Chapter 3</a> <a href="#">Page 75</a>
	Right-angled profile	<b>HO9810</b>	6.5 m	SW+s; SW+g; BR+s; CA+s; AN+s	<input type="checkbox"/>   <input type="checkbox"/> <input type="checkbox"/>	<a href="#">Chapter 3</a> <a href="#">Page 74</a>
	Faceplate right-angled profile	<b>HO9820</b>	6.5 m	SW+s; SW+g; AN+s	<input type="checkbox"/>   <input type="checkbox"/> <input type="checkbox"/>	<a href="#">Chapter 3</a> <a href="#">Page 72</a>

Main profiles

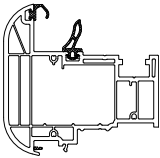
Colour base body: PW = pureWhite; CA = caramel; BR = brown; AN = anthracite, CR = cream; GL = Greta@Fenster_loop SW = solidWhite Colour seal: s = black; g = grey; l = light grey (suitable with Greta@Fenster_loop) Décor: <input type="checkbox"/> = without <input type="checkbox"/>   = on both sides      <input type="checkbox"/> = outside <input type="checkbox"/>   = inside						
Illustration	Description	Article no.	Length / PU	Colour main body+colour gasket	Pattern	From page
	Right-angled profile	<b>HO9850</b>	6.5 m	SW+s; SW+g; BR+s; CA+s; AN+s	<input type="checkbox"/>   <input type="checkbox"/> <input type="checkbox"/>	<a href="#">Chapter 3</a> <a href="#">Page 76</a>



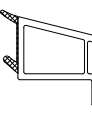
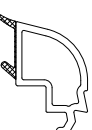
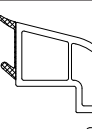
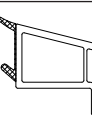
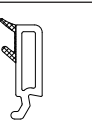

Glazing beads, gaskets

Colour base body: PW = pureWhite; CA = caramel; BR = brown; AN = anthracite, CR = cream; GL = Greta@Fenster_loop SW = solidWhite Colour seal: s = black; g = grey; l = light grey (suitable with Greta@Fenster_loop) Décor: <input type="checkbox"/> = without <input type="checkbox"/> = on both sides <input type="checkbox"/> = outside <input type="checkbox"/> = inside						
Illustration	Description	Article no.	Length / PU	Colour main body+colour gasket	Pattern	From page
<b>Glazing beads</b>						
	Glazing bead	<b>413001</b>	6 m	PW+s; PW+g; SW+s; SW+g; BR+s; GL+l	<input type="checkbox"/> <input type="checkbox"/> l	<a href="#">Chapter 3</a> <a href="#">Page 84</a>
	Glazing bead	<b>413003</b>	6 m	PW+s; PW+g; SW+s; SW+g; BR+s; CR+g; GL+l	<input type="checkbox"/> <input type="checkbox"/> l	<a href="#">Chapter 3</a> <a href="#">Page 84</a>
	Glazing bead	<b>413005</b>	6 m	PW+s; PW+g; SW+s; SW+g; BR+s; GL+l	<input type="checkbox"/> <input type="checkbox"/> l	<a href="#">Chapter 3</a> <a href="#">Page 84</a>
	Glazing bead	<b>413007</b>	6 m	PW+s; PW+g; SW+s; SW+g; BR+s; GL+l	<input type="checkbox"/> <input type="checkbox"/> l	<a href="#">Chapter 3</a> <a href="#">Page 84</a>
	Glazing bead	<b>413009</b>	6 m	PW+s; PW+g; SW+s; SW+g; BR+s	<input type="checkbox"/> <input type="checkbox"/> l	<a href="#">Chapter 3</a> <a href="#">Page 84</a>
	Glazing bead	<b>413011</b>	6 m	PW+s; PW+g; SW+s; SW+g; BR+s; CR+g; GL+l	<input type="checkbox"/> <input type="checkbox"/> l	<a href="#">Chapter 3</a> <a href="#">Page 84</a>
	Glazing bead	<b>413013</b>	6 m	PW+s; PW+g; SW+s; SW+g; BR+s	<input type="checkbox"/> <input type="checkbox"/> l	<a href="#">Chapter 3</a> <a href="#">Page 84</a>
	Glazing-bead	<b>413301</b>	6 m	PW+s; PW+g; BR+s; GL+l	<input type="checkbox"/> <input type="checkbox"/> l	<a href="#">Chapter 3</a> <a href="#">Page 81</a>
	Glazing-bead	<b>413303</b>	6 m	PW+s; PW+g; SW+s; SW+g; BR+s; GL+l	<input type="checkbox"/> <input type="checkbox"/> l	<a href="#">Chapter 3</a> <a href="#">Page 81</a>
	Glazing-bead	<b>413305</b>	6 m	PW+s; PW+g; SW+s; SW+g; BR+s; GL+l	<input type="checkbox"/> <input type="checkbox"/> l	<a href="#">Chapter 3</a> <a href="#">Page 81</a>



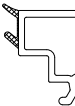
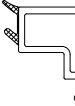
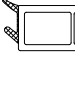
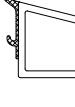
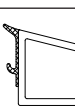
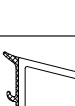

## Glazing beads, gaskets

Colour base body:		PW = pureWhite; CA = caramel; BR = brown; AN = anthracite, CR = cream; GL = Greta@Fenster_loop SW = solidWhite					
Colour seal:		s = black; g = grey; l = light grey (suitable with Greta@Fenster_loop)					
Décor:		□ = without		□  = on both sides		□ = outside	□  = inside
Illustration	Description	Article no.	Length / PU	Colour main body+colour gasket	Pattern	From page	
	Glazing-bead	<b>413307</b>	6 m	PW+s; PW+g; BR+s; GL+l	□ □	<a href="#">Chapter 3</a> <a href="#">Page 81</a>	
	Glazing bead	<b>413309</b>	6 m	PW+s; PW+g; BR+s	□ □	<a href="#">Chapter 3</a> <a href="#">Page 81</a>	
	Glazing-bead	<b>413311</b>	6 m	PW+s; PW+g; BR+s; GL+l	□ □	<a href="#">Chapter 3</a> <a href="#">Page 81</a>	
	Glazing-bead	<b>413313</b>	6 m	PW+s; PW+g; BR+s; GL+l	□ □	<a href="#">Chapter 3</a> <a href="#">Page 81</a>	
	Glazing-bead curve	<b>413103</b>	6 m	PW+s; PW+g; BR+s; CR+g	□ □	<a href="#">Chapter 3</a> <a href="#">Page 82</a>	
	Glazing-bead curve	<b>413105</b>	6 m	PW+s; PW+g; BR+s	□ □	<a href="#">Chapter 3</a> <a href="#">Page 82</a>	
	Glazing-bead curve	<b>413107</b>	6 m	PW+s; PW+g; SW+s; SW+g; BR+s	□ □	<a href="#">Chapter 3</a> <a href="#">Page 82</a>	
	Glazing-bead curve	<b>413111</b>	6 m	PW+s; PW+g; BR+s; CR+g	□ □	<a href="#">Chapter 3</a> <a href="#">Page 82</a>	
	Glazing-bead curve	<b>413113</b>	6 m	PW+s; PW+g; BR+s	□ □	<a href="#">Chapter 3</a> <a href="#">Page 82</a>	
	Glazing bead box	<b>413201</b>	6 m	PW+s; PW+g; BR+s	□ □	<a href="#">Chapter 3</a> <a href="#">Page 85</a>	



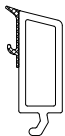
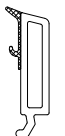
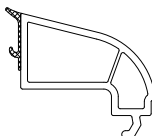
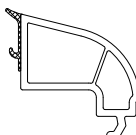
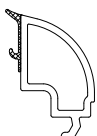
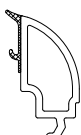
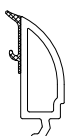











Glazing beads, gaskets

Colour base body: PW = pureWhite; CA = caramel; BR = brown; AN = anthracite, CR = cream; GL = Greta@Fenster_loop SW = solidWhite Colour seal: s = black; g = grey; l = light grey (suitable with Greta@Fenster_loop) Décor: <input type="checkbox"/> = without <input type="checkbox"/> = on both sides <input type="checkbox"/> = outside <input type="checkbox"/> = inside						
Illustration	Description	Article no.	Length / PU	Colour main body+colour gasket	Pattern	From page
	Glazing bead box	<b>413205</b>	6 m	PW+s; PW+g; BR+s	<input type="checkbox"/> <input type="checkbox"/> l	<a href="#">Chapter 3</a> <a href="#">Page 85</a>
	Glazing bead box	<b>413207</b>	6 m	PW+s; PW+g; BR+s; CR+g	<input type="checkbox"/> <input type="checkbox"/> l	<a href="#">Chapter 3</a> <a href="#">Page 85</a>
	Glazing bead box	<b>413209</b>	6 m	PW+s; PW+g; BR+s	<input type="checkbox"/> <input type="checkbox"/> l	<a href="#">Chapter 3</a> <a href="#">Page 85</a>
	Glazing bead box	<b>413211</b>	6 m	PW+s; PW+g; BR+s	<input type="checkbox"/> <input type="checkbox"/> l	<a href="#">Chapter 3</a> <a href="#">Page 85</a>
	Glazing bead	<b>GP8240</b>	6 m	PW+s; PW+g; SW+s; SW+g; BR+s; GL+l	<input type="checkbox"/> <input type="checkbox"/> l	<a href="#">Chapter 3</a> <a href="#">Page 78</a>
	Glazing bead	<b>GP8280</b>	6 m	PW+s; PW+g; SW+s; SW+g; BR+s; GL+l	<input type="checkbox"/> <input type="checkbox"/> l	<a href="#">Chapter 3</a> <a href="#">Page 78</a>
	Glazing bead	<b>GP8320</b>	6 m	PW+s; PW+g; SW+s; SW+g; BR+s	<input type="checkbox"/> <input type="checkbox"/> l	<a href="#">Chapter 3</a> <a href="#">Page 78</a>
	Glazing bead	<b>GP8360</b>	6 m	PW+s; PW+g; SW+s; SW+g; BR+s; GL+l	<input type="checkbox"/> <input type="checkbox"/> l	<a href="#">Chapter 3</a> <a href="#">Page 78</a>
	Glazing bead	<b>GP8400</b>	6 m	PW+s; PW+g; SW+s; SW+g; BR+s	<input type="checkbox"/> <input type="checkbox"/> l	<a href="#">Chapter 3</a> <a href="#">Page 78</a>
	Glazing bead	<b>GP8440</b>	6 m	PW+s; PW+g; SW+s; SW+g; BR+s; GL+l	<input type="checkbox"/> <input type="checkbox"/> l	<a href="#">Chapter 3</a> <a href="#">Page 78</a>

## Glazing beads, gaskets

Colour base body:		PW = pureWhite; CA = caramel; BR = brown; AN = anthracite, CR = cream; GL = Greta@Fenster_loop SW = solidWhite				
Colour seal:		s = black; g = grey; l = light grey (suitable with Greta@Fenster_loop)				
Décor:		<input type="checkbox"/> = without	<input type="checkbox"/> = on both sides	<input type="checkbox"/> = outside	<input type="checkbox"/> = inside	
Illustration	Description	Article no.	Length / PU	Colour main body+colour gasket	Pattern	From page
	Glazing bead	<b>GP8480</b>	6 m	PW+s; PW+g; SW+s; SW+g; BR+s; GL+l	<input type="checkbox"/> <input type="checkbox"/> l	<a href="#">Chapter 3</a> <a href="#">Page 78</a>
	Glazing bead	<b>GP8520</b>	6 m	PW+s; PW+g; SW+s; SW+g; BR+s; GL+l	<input type="checkbox"/> <input type="checkbox"/> l	<a href="#">Chapter 3</a> <a href="#">Page 78</a>
	Glazing-bead curve	<b>GP9240</b>	6 m	SW+s; SW+g; BR+s	<input type="checkbox"/> <input type="checkbox"/> l	<a href="#">Chapter 3</a> <a href="#">Page 79</a>
	Glazing-bead curve	<b>GP9280</b>	6 m	SW+s; SW+g; BR+s	<input type="checkbox"/> <input type="checkbox"/> l	<a href="#">Chapter 3</a> <a href="#">Page 79</a>
	Glazing-bead curve	<b>GP9400</b>	6 m	SW+s; SW+g; BR+s	<input type="checkbox"/> <input type="checkbox"/> l	<a href="#">Chapter 3</a> <a href="#">Page 79</a>
	Glazing-bead curve	<b>GP9440</b>	6 m	SW+s; SW+g; BR+s	<input type="checkbox"/> <input type="checkbox"/> l	<a href="#">Chapter 3</a> <a href="#">Page 79</a>
	Glazing-bead curve	<b>GP9480</b>	6 m	SW+s; SW+g; BR+s	<input type="checkbox"/> <input type="checkbox"/> l	<a href="#">Chapter 3</a> <a href="#">Page 79</a>
<b>Gaskets</b>						
	Brush seal	<b>DP7010</b>	225 m	Grey	-	<a href="#">Chapter 3</a> <a href="#">Page 91</a>
	Stopper gasket	<b>DP7230</b>	200 m	Black, grey	-	<a href="#">Chapter 3</a> <a href="#">Page 91</a>
	Stop and glazing gasket	<b>DP8110</b>	100 m	Black, grey	-	<a href="#">Chapter 3</a> <a href="#">Page 88</a>
	Stop and glazing gasket	<b>DP8160</b>	300 m	Black, grey	-	<a href="#">Chapter 3</a> <a href="#">Page 88</a>







Glazing beads, gaskets

Colour base body: PW = pureWhite; CA = caramel; BR = brown; AN = anthracite, CR = cream; GL = Greta@Fenster_loop SW = solidWhite Colour seal: s = black; g = grey; l = light grey (suitable with Greta@Fenster_loop) Décor: <input type="checkbox"/> = without <input type="checkbox"/> = on both sides <input type="checkbox"/> = outside <input type="checkbox"/> = inside						
Illustration	Description	Article no.	Length / PU	Colour main body+colour gasket	Pattern	From page
	Glazing gasket	<b>DP8410</b>	100 m	Black, grey	-	<a href="#">Chapter 3</a> <a href="#">Page 88</a>
	Glazing gasket	<b>DP8480</b>	300 m	Black, grey	-	<a href="#">Chapter 3</a> <a href="#">Page 88</a>
	Stopper gasket	<b>DP8610</b>	300 m	Black, grey	-	<a href="#">Chapter 3</a> <a href="#">Page 88</a>
	Stopper gasket	<b>DP8660</b>	400 m	Black, grey	-	<a href="#">Chapter 3</a> <a href="#">Page 88</a>
	Main door stopper gasket	<b>DP8860</b>	300 m	Black, grey	-	<a href="#">Chapter 3</a> <a href="#">Page 88</a>
	Main door stopper gasket	<b>DP8865</b>	200 m	Black, grey	-	<a href="#">Chapter 3</a> <a href="#">Page 88</a>
	Central gasket	<b>DP9110</b>	100 m	Black, grey	-	<a href="#">Chapter 3</a> <a href="#">Page 88</a>
	Brush seal	<b>404930</b>	100 m	Black	-	<a href="#">Chapter 3</a> <a href="#">Page 91</a>
	Brush seal	<b>404935</b>	100 m	Black	-	<a href="#">Chapter 3</a> <a href="#">Page 91</a>
	Gasket	<b>414566</b>	300 m / roll	Black, grey	-	<a href="#">Chapter 3</a> <a href="#">Page 90</a>
	Glazing gasket	<b>414573</b>	200 m / roll	Black, grey	-	<a href="#">Chapter 3</a> <a href="#">Page 90</a>
	Brush seal	<b>414971</b>	225 m / roll	Grey	-	<a href="#">Chapter 3</a> <a href="#">Page 91</a>
	Combination gasket	<b>464100</b>	100 m	Black, grey	-	<a href="#">Chapter 3</a> <a href="#">Page 90</a>
	Stopper gasket	<b>464101</b>	100 m	Black, grey	-	<a href="#">Chapter 3</a> <a href="#">Page 90</a>
	Stopper gasket	<b>464203</b>	100 m	Black, grey	-	<a href="#">Chapter 3</a> <a href="#">Page 90</a>

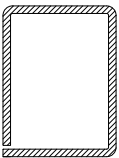
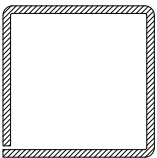
## Glass rebate bridges, glass blocks, strengthenings

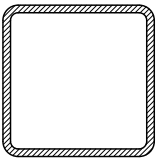
Colour base body:		PW = pureWhite; CA = caramel; BR = brown; AN = anthracite, CR = cream; GL = Greta@Fenster_loop SW = solidWhite				
Colour seal:		s = black; g = grey; l = light grey (suitable with Greta@Fenster_loop)				
Décor:		□ = without	□□ = on both sides	□□ = outside	□□□ = inside	
Illustration	Description	Article no.	Length / PU	Colour main body+colour gasket	Pattern	From page
<b>Block bridges and glass blocks</b>						
	Glass rebate bridge	<b>GZ8010</b>	100 pc.	Grey	-	<a href="#">Chapter 3</a> <a href="#">Page 92</a>
	Glass rebate bridge	<b>GZ9010</b>	100 pc.	Grey	-	<a href="#">Chapter 3</a> <a href="#">Page 92</a>
	Glass blocks 30 mm wide, 2 – 6 mm thick	<b>417212 - 417216</b>	per 1000 pc.	Colourful	-	<a href="#">Chapter 3</a> <a href="#">Page 92</a>
	Glass blocks 34 mm wide, 2 – 6 mm thick	<b>417222 - 417226</b>	per 1000 pc.	Colourful	-	<a href="#">Chapter 3</a> <a href="#">Page 92</a>
	Glass blocks 40 mm wide, 2 – 5 mm thick	<b>417232 - 417235</b>	per 1000 pc.	Colourful	-	<a href="#">Chapter 3</a> <a href="#">Page 92</a>
	Glass blocks 48 mm wide, 2 – 5 mm thick	<b>417242 - 417245</b>	per 1000 pc.	Colourful	-	<a href="#">Chapter 3</a> <a href="#">Page 92</a>
	Glass blocks 50 mm wide, 2 – 5 mm thick	<b>417252 - 417255</b>	per 1000 pc.	Colourful	-	<a href="#">Chapter 3</a> <a href="#">Page 92</a>
	Glass blocks 52 mm wide, 2 – 5 mm thick	<b>417262 - 417265</b>	per 1000 pc.	Colourful	-	<a href="#">Chapter 3</a> <a href="#">Page 92</a>
<b>Strengthening</b>						
	Strengthening	<b>105011</b>	6 m	Steel, galvanised	-	<a href="#">Chapter 3</a> <a href="#">Page 93</a>
	Strengthening	<b>405015</b>	6 m	Steel, galvanised	-	<a href="#">Chapter 3</a> <a href="#">Page 93</a>

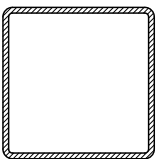
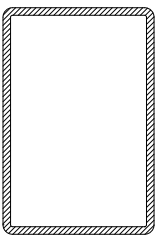
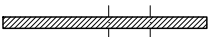
Glass rebate bridges, glass blocks, strengthenings

Colour base body: PW = pureWhite; CA = caramel; BR = brown; AN = anthracite, CR = cream; GL = Greta@Fenster_loop SW = solidWhite Colour seal: s = black; g = grey; l = light grey (suitable with Greta@Fenster_loop) Décor: <input type="checkbox"/> = without <input type="checkbox"/> = on both sides <input type="checkbox"/> = outside <input type="checkbox"/> = inside						
Illustration	Description	Article no.	Length / PU	Colour main body+colour gasket	Pattern	From page
	Strengthening	<b>405040</b>	6 m	Steel, galvanised	-	<a href="#">Chapter 3</a> <a href="#">Page 93</a>
	Strengthening	<b>405060</b>	6 m	Steel, galvanised	-	<a href="#">Chapter 3</a> <a href="#">Page 93</a>
	Strengthening	<b>405065</b>	6 m	Steel, galvanised	-	<a href="#">Chapter 3</a> <a href="#">Page 93</a>
	Strengthening	<b>405125</b>	6 m	Steel, galvanised	-	<a href="#">Chapter 3</a> <a href="#">Page 93</a>
	Strengthening	<b>415040</b>	6 m	Steel, galvanised	-	<a href="#">Chapter 3</a> <a href="#">Page 93</a>
	Strengthening	<b>475021</b>	6 m	Steel, galvanised	-	<a href="#">Chapter 3</a> <a href="#">Page 93</a>
	Strengthening	<b>715303</b>	6 m	Steel, galvanised	-	<a href="#">Chapter 3</a> <a href="#">Page 93</a>
	Strengthening	<b>AR4630</b>	6 m	Steel, galvanised	-	<a href="#">Chapter 3</a> <a href="#">Page 93</a>
	Rebate reinforcement	<b>MT8500</b>	4.5 m	Steel, galvanised	-	<a href="#">Chapter 3</a> <a href="#">Page 93</a>
	Rebate reinforcement	<b>465022</b>	6 m	Steel, galvanised	-	<a href="#">Chapter 3</a> <a href="#">Page 93</a>



## Glass rebate bridges, glass blocks, strengthenings

Colour base body: PW = pureWhite; CA = caramel; BR = brown; AN = anthracite, CR = cream; GL = Greta@Fenster_loop SW = solidWhite Colour seal: s = black; g = grey; l = light grey (suitable with Greta@Fenster_loop) Décor: <input type="checkbox"/> = without <input type="checkbox"/> = on both sides <input type="checkbox"/> = outside <input type="checkbox"/> = inside						
Illustration	Description	Article no.	Length / PU	Colour main body+colour gasket	Pattern	From page
	Strengthening	<b>MT8530</b>	6.5 m	Steel, galvanised	-	<a href="#">Chapter 3</a> <a href="#">Page 93</a>
	Strengthening	<b>MT8551</b>	6.5 m	Steel, galvanised	-	<a href="#">Chapter 3</a> <a href="#">Page 93</a>
	Strengthening	<b>VS1010</b>	6 m	Steel, galvanised	-	<a href="#">Chapter 3</a> <a href="#">Page 93</a>
	Strengthening	<b>VS1020</b>	6 m	Steel, galvanised	-	<a href="#">Chapter 3</a> <a href="#">Page 93</a>
	Strengthening	<b>VS1120</b>	6 m	Steel, galvanised	-	<a href="#">Chapter 3</a> <a href="#">Page 93</a>
	Strengthening	<b>VS3030</b>	6 m	Steel, galvanised	-	<a href="#">Chapter 3</a> <a href="#">Page 93</a>
	Strengthening	<b>VS4020</b>	6 m	Steel, galvanised	-	<a href="#">Chapter 3</a> <a href="#">Page 93</a>
	Strengthening	<b>VS8020</b>	6 m	Steel, galvanised	-	<a href="#">Chapter 3</a> <a href="#">Page 93</a>
	Strengthening	<b>VS8030</b>	6 m	Steel, galvanised	-	<a href="#">Chapter 3</a> <a href="#">Page 93</a>

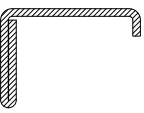
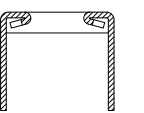

Glass rebate bridges, glass blocks, strengthenings

Colour base body: PW = pureWhite; CA = caramel; BR = brown; AN = anthracite, CR = cream; GL = Greta@Fenster_loop SW = solidWhite Colour seal: s = black; g = grey; l = light grey (suitable with Greta@Fenster_loop) Décor: <input type="checkbox"/> = without <input type="checkbox"/> = on both sides <input type="checkbox"/> = outside <input type="checkbox"/> = inside						
Illustration	Description	Article no.	Length / PU	Colour main body+colour gasket	Pattern	From page
	Strengthening	<b>VS8050</b>	6 m	Steel, galvanised	-	<a href="#">Chapter 3</a> <a href="#">Page 93</a>
	Strengthening	<b>VS8055</b>	6 m	Steel, galvanised	-	<a href="#">Chapter 3</a> <a href="#">Page 93</a>
	Strengthening	<b>VS8160</b>	6 m	Steel, galvanised	-	<a href="#">Chapter 3</a> <a href="#">Page 93</a>
	Strengthening	<b>VS8230</b>	6 m	Steel, galvanised	-	<a href="#">Chapter 3</a> <a href="#">Page 93</a>
	Strengthening	<b>VS8300</b>	6 m	Steel, galvanised	-	<a href="#">Chapter 3</a> <a href="#">Page 93</a>
	Strengthening	<b>VS8310</b>	6 m	Steel, galvanised	-	<a href="#">Chapter 3</a> <a href="#">Page 93</a>
	Strengthening	<b>VS8320</b>	6 m	Steel, galvanised	-	<a href="#">Chapter 3</a> <a href="#">Page 93</a>
	Strengthening	<b>VS8420</b>	6 m	Steel, galvanised	-	<a href="#">Chapter 3</a> <a href="#">Page 93</a>
	Strengthening	<b>VS8450</b>	6 m	Steel, galvanised	-	<a href="#">Chapter 3</a> <a href="#">Page 93</a>
	Strengthening	<b>VS8510</b>	6 m	Steel, galvanised	-	<a href="#">Chapter 3</a> <a href="#">Page 93</a>

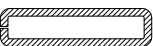
## Glass rebate bridges, glass blocks, strengthenings

Colour base body: PW = pureWhite; CA = caramel; BR = brown; AN = anthracite, CR = cream; GL = Greta@Fenster_loop SW = solidWhite Colour seal: s = black; g = grey; l = light grey (suitable with Greta@Fenster_loop) Décor: <input type="checkbox"/> = without <input type="checkbox"/> = on both sides <input type="checkbox"/> = outside <input type="checkbox"/> = inside						
Illustration	Description	Article no.	Length / PU	Colour main body+colour gasket	Pattern	From page
	Strengthening	<b>VS8520</b>	6 m	Steel, galvanised	-	<a href="#">Chapter 3</a> <a href="#">Page 93</a>
	Strengthening	<b>VS8620</b>	6 m	Steel, galvanised	-	<a href="#">Chapter 3</a> <a href="#">Page 93</a>
	Strengthening	<b>VS9029</b>	6 m	Steel, galvanised	-	<a href="#">Chapter 3</a> <a href="#">Page 93</a>
	Strengthening	<b>VS9800</b>	6 m	Steel, galvanised	-	<a href="#">Chapter 3</a> <a href="#">Page 93</a>
	Strengthening	<b>VS9810</b>	6 m	Steel, galvanised	-	<a href="#">Chapter 3</a> <a href="#">Page 93</a>

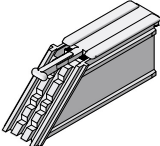
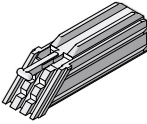
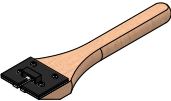
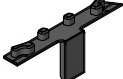
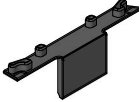
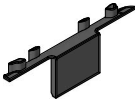
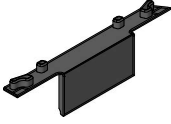
Side profiles and accessories

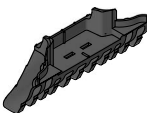
Colour base body: PW = pureWhite; CA = caramel; BR = brown; AN = anthracite, CR = cream; GL = Greta@Fenster_loop SW = solidWhite Colour seal: s = black; g = grey; l = light grey (suitable with Greta@Fenster_loop) Décor: <input type="checkbox"/> = without <input type="checkbox"/> = on both sides <input type="checkbox"/> = outside <input type="checkbox"/> = inside						
Illustration	Description	Article no.	Length / PU	Colour main body+colour gasket	Pattern	From page
<b>Weldable corner connector</b>						
	Weldable corner connector	<b>MT4631</b>	40 pc.	Colourful	-	<a href="#">Chapter 3</a> <a href="#">Page 102</a>
	Weldable corner connector	<b>MT8540</b>	40 pc.	Colourful	-	<a href="#">Chapter 3</a> <a href="#">Page 102</a>
	Clamping lever	<b>207910</b>	1 pc.	-	-	<a href="#">Chapter 3</a> <a href="#">Page 102</a>
<b>Glazing bar and fixed-mullion connectors</b>						
	Sealing block	<b>MT8200</b>	100 pc.	Black	-	<a href="#">Chapter 3</a> <a href="#">Page 103</a>
	Sealing block	<b>MT8220</b>	100 pc.	Black	-	<a href="#">Chapter 3</a> <a href="#">Page 103</a>
	Sealing block	<b>MT8230</b>	100 pc.	Black	-	<a href="#">Chapter 3</a> <a href="#">Page 103</a>
	Sealing block	<b>MT8240</b>	100 pc.	Black	-	<a href="#">Chapter 3</a> <a href="#">Page 103</a>
	Sealing fitting	<b>MT9010</b>	100 pc.	Black	-	<a href="#">Chapter 3</a> <a href="#">Page 103</a>
	Sealing pad	<b>MT9310</b>	100 pc.	Black	-	<a href="#">Chapter 3</a> <a href="#">Page 103</a>
	Sealing block	<b>MT9320</b>	100 pc.	Black	-	<a href="#">Chapter 3</a> <a href="#">Page 103</a>





## Side profiles and accessories

Colour base body:		PW = pureWhite; CA = caramel; BR = brown; AN = anthracite, CR = cream; GL = Greta@Fenster_loop SW = solidWhite					
Colour seal:		s = black; g = grey; l = light grey (suitable with Greta@Fenster_loop)					
Décor:		□ = without		□  = on both sides		□ = outside	□ = inside
Illustration	Description	Article no.	Length / PU	Colour main body+colour gasket	Pattern	From page	
	Sealing pad	<b>MT9330</b>	100 pc.	Black	-	<a href="#">Chapter 3</a> <a href="#">Page 103</a>	
	Sealing block	<b>MT9340</b>	100 pc.	Black	-	<a href="#">Chapter 3</a> <a href="#">Page 103</a>	
	Fixed-mullion connector set	<b>ZS8300</b>	50 pc.	Silver	-	<a href="#">Chapter 3</a> <a href="#">Page 103</a>	
	Fixed-mullion connector set	<b>ZS8303</b>	10 pc.	Silver	-	<a href="#">Chapter 3</a> <a href="#">Page 103</a>	
	Fixed-mullion connector set	<b>ZS8320</b>	50 pc.	Silver	-	<a href="#">Chapter 3</a> <a href="#">Page 103</a>	
	Fixed-mullion connector set	<b>ZS8323</b>	10 pc.	Silver	-	<a href="#">Chapter 3</a> <a href="#">Page 103</a>	
	Fixed-mullion connector set	<b>ZS8340</b>	50 pc.	Silver	-	<a href="#">Chapter 3</a> <a href="#">Page 103</a>	
	Fixed-mullion connector set	<b>ZS8343</b>	10 pc.	Silver	-	<a href="#">Chapter 3</a> <a href="#">Page 103</a>	
	Fixed-mullion connector set	<b>ZS8420</b>	50 pc.	Silver	-	<a href="#">Chapter 3</a> <a href="#">Page 103</a>	
	Fixed-mullion connector set	<b>ZS9320</b>	50 pc.	Silver	-	<a href="#">Chapter 3</a> <a href="#">Page 103</a>	
	Fixed-mullion connector set	<b>ZS9321</b>	50 pc.	Silver	-	<a href="#">Chapter 3</a> <a href="#">Page 103</a>	



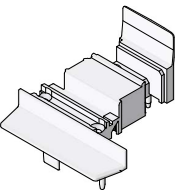
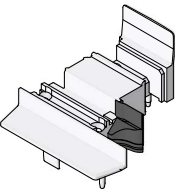
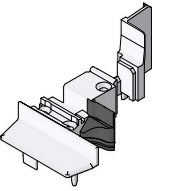
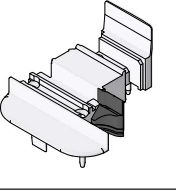
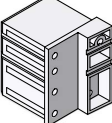





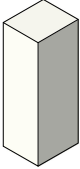
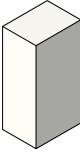

Side profiles and accessories

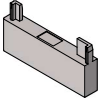
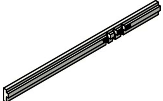
Colour base body: PW = pureWhite; CA = caramel; BR = brown; AN = anthracite, CR = cream; GL = Greta@Fenster_loop SW = solidWhite Colour seal: s = black; g = grey; l = light grey (suitable with Greta@Fenster_loop) Décor: <input type="checkbox"/> = without <input type="checkbox"/> = on both sides <input type="checkbox"/> = outside <input type="checkbox"/> = inside						
Illustration	Description	Article no.	Length / PU	Colour main body+colour gasket	Pattern	From page
	Post cross connector set	<b>ZS9341</b>	50 pc.	Silver	-	<a href="#">Chapter 3</a> <a href="#">Page 103</a>
	Fixed-mullion connector set	<b>ZS9420</b>	50 pc.	Silver	-	<a href="#">Chapter 3</a> <a href="#">Page 103</a>
<b>Floating-mullion end cover caps</b>						
	Floating-mullion end cover cap inside	<b>ES9801</b>	100 pc.	SW; BR; CA; black	-	<a href="#">Chapter 3</a> <a href="#">Page 106</a>
	Floating-mullion end cover cap outside	<b>ES9810</b>	100 pc.	SW; BR; CA; black	-	<a href="#">Chapter 3</a> <a href="#">Page 106</a>
	Floating-mullion end cover cap inside	<b>ES9821</b>	100 pc.	SW; BR; CA; black	-	<a href="#">Chapter 3</a> <a href="#">Page 106</a>
	Floating-mullion end cover cap outside	<b>ES9830</b>	100 pc.	SW; BR; CA; black	-	<a href="#">Chapter 3</a> <a href="#">Page 106</a>
	Floating-mullion end cover cap outside	<b>ES9850</b>	100 pc.	SW; BR; CA; black	-	<a href="#">Chapter 3</a> <a href="#">Page 106</a>
	Cover cap	<b>ES9860</b>	100 pc.	SW; BR; CA; black	-	<a href="#">Chapter 3</a> <a href="#">Page 106</a>
	Sealing fitting	<b>MT9800</b>	100 pc.	Black, grey	-	<a href="#">Chapter 3</a> <a href="#">Page 106</a>
	Faceplate end cover cap set	<b>ZS9820</b>	40 pc.	SW; BR; CA; black	-	<a href="#">Chapter 3</a> <a href="#">Page 106</a>

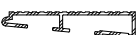
## Side profiles and accessories

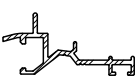
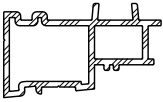
Colour base body: PW = pureWhite; CA = caramel; BR = brown; AN = anthracite, CR = cream; GL = Greta@Fenster_loop SW = solidWhite Colour seal: s = black; g = grey; l = light grey (suitable with Greta@Fenster_loop) Décor: <input type="checkbox"/> = without <input type="checkbox"/> = on both sides <input type="checkbox"/> = outside <input type="checkbox"/> = inside						
Illustration	Description	Article no.	Length / PU	Colour main body+colour gasket	Pattern	From page
	Faceplate end cover cap set	<b>ZS8801</b>	40 pc.	SW; BR; CA; black	-	<a href="#">Chapter 3</a> <a href="#">Page 106</a>
	Faceplate end cover cap set	<b>ZS9801</b>	40 pc.	SW; BR; CA; black	-	<a href="#">Chapter 3</a> <a href="#">Page 106</a>
	Faceplate end cover cap set	<b>ZS9811</b>	40 pc.	SW; BR; CA; black	-	<a href="#">Chapter 3</a> <a href="#">Page 106</a>
	Faceplate end cover cap set	<b>ZS9851</b>	40 pc.	SW; BR; CA; black	-	<a href="#">Chapter 3</a> <a href="#">Page 106</a>
<b>Door thresholds</b>						
	Threshold holder	<b>ES2040</b>	20 pc.	White	-	<a href="#">Chapter 3</a> <a href="#">Page 121</a>
	Protective cap for French door DIN left	<b>ES7215</b>	Upon request	Black	-	<a href="#">Chapter 3</a> <a href="#">Page 120</a>
	Protective cap for French door DIN right	<b>ES7216</b>	Upon request	Black	-	<a href="#">Chapter 3</a> <a href="#">Page 120</a>
	Protective cap for French door DIN left	<b>ES7217</b>	Upon request	Black	-	<a href="#">Chapter 3</a> <a href="#">Page 120</a>
	Protective cap for French door DIN right	<b>ES7218</b>	Upon request	Black	-	<a href="#">Chapter 3</a> <a href="#">Page 120</a>

Side profiles and accessories

Colour base body: PW = pureWhite; CA = caramel; BR = brown; AN = anthracite, CR = cream; GL = Greta@Fenster_loop SW = solidWhite Colour seal: s = black; g = grey; l = light grey (suitable with Greta@Fenster_loop) Décor: <input type="checkbox"/> = without <input type="checkbox"/> = on both sides <input type="checkbox"/> = outside <input type="checkbox"/> = inside						
Illustration	Description	Article no.	Length / PU	Colour main body+colour gasket	Pattern	From page
	Screw block	<b>MT7131</b>	100 pc.	-	-	<a href="#">Chapter 3</a> <a href="#">Page 117</a>
	Screw block	<b>MT7132</b>	100 pc.	-	-	<a href="#">Chapter 3</a> <a href="#">Page 117</a>
	Adapter	<b>MT7575</b>	75 set / carton (R+L)	Grey	-	<a href="#">Chapter 3</a> <a href="#">Page 112</a>
	Adapter	<b>MT7580</b>	75 set / carton (R+L)	Grey	-	<a href="#">Chapter 3</a> <a href="#">Page 112</a>
	Strike plate compensation piece	<b>MT7950</b>	100 pc.	Grey	-	<a href="#">Chapter 3</a> <a href="#">Page 121</a>
	Cover profile	<b>NP7120</b>	6 m	Grey	-	<a href="#">Chapter 3</a> <a href="#">Page 110</a>
	Attachment profile	<b>VA7125</b>	6 m	Aluminium	-	<a href="#">Chapter 3</a> <a href="#">Page 110</a>
	Weather profile strip	<b>VA7215</b>	6 m	Aluminium	-	<a href="#">Chapter 3</a> <a href="#">Page 120</a>
	Weather profile strip	<b>VA7231</b>	6 m	Aluminium	-	<a href="#">Chapter 3</a> <a href="#">Page 111</a>
	Compensating piece	<b>VA7410</b>	6 m	Aluminium	-	<a href="#">Chapter 3</a> <a href="#">Page 121</a>
	Door threshold	<b>ZS7110</b>	6 m	Grey	-	<a href="#">Chapter 3</a> <a href="#">Page 110</a>
	Door threshold	<b>ZS7120</b>	6 m	Grey	-	<a href="#">Chapter 3</a> <a href="#">Page 110</a>
	Door threshold	<b>ZS7125</b>	6 m	Grey	-	<a href="#">Chapter 3</a> <a href="#">Page 111</a>
	Door threshold	<b>ZS7130</b>	6 m	Grey	-	<a href="#">Chapter 3</a> <a href="#">Page 111</a>

## Side profiles and accessories

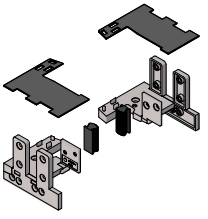
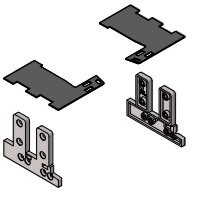
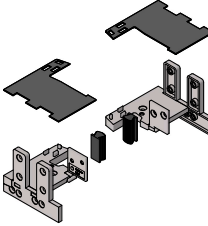
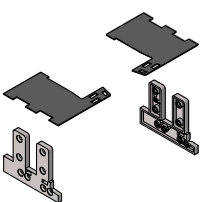
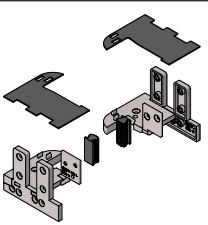
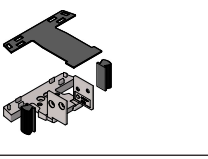
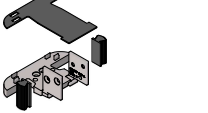
Colour base body:		PW = pureWhite; CA = caramel; BR = brown; AN = anthracite, CR = cream; GL = Greta@Fenster_loop SW = solidWhite					
Colour seal:		s = black; g = grey; l = light grey (suitable with Greta@Fenster_loop)					
Décor:		□ = without		□  = on both sides		□ = outside	□ = inside
Illustration	Description	Article no.	Length / PU	Colour main body+colour gasket	Pattern	From page	
	Threshold holder set	<b>ZS7520</b>	75 set / carton (R+L)	Grey	-	<a href="#">Chapter 3</a> <a href="#">Page 112</a>	
	Threshold holder set	<b>ZS7525</b>	75 set / carton (R+L)	Grey	-	<a href="#">Chapter 3</a> <a href="#">Page 115</a>	
	Threshold holder set	<b>ZS7530</b>	75 set / carton (R+L)	Grey	-	<a href="#">Chapter 3</a> <a href="#">Page 114</a>	
	Threshold holder set	<b>ZS7535</b>	75 set / carton (R+L)	Grey	-	<a href="#">Chapter 3</a> <a href="#">Page 116</a>	
	Threshold holder set	<b>ZS7620</b>	75 set / carton (R+L)	Grey	-	<a href="#">Chapter 3</a> <a href="#">Page 113</a>	
	Threshold holder set	<b>ZS7820</b>	75 pc. / carton	Grey	-	<a href="#">Chapter 3</a> <a href="#">Page 118</a>	
	Threshold holder set	<b>ZS7840</b>	75 pc. / carton	Grey	-	<a href="#">Chapter 3</a> <a href="#">Page 118</a>	

Side profiles and accessories

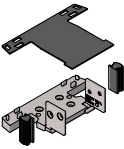
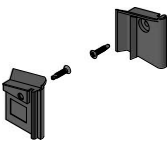
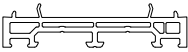
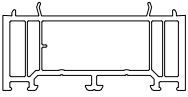
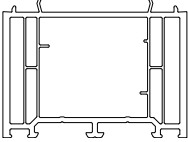
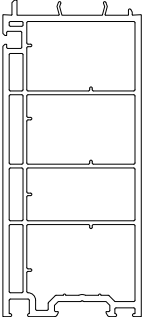
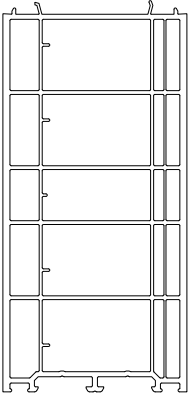
Colour base body: PW = pureWhite; CA = caramel; BR = brown; AN = anthracite, CR = cream; GL = Greta@Fenster_loop SW = solidWhite Colour seal: s = black; g = grey; l = light grey (suitable with Greta@Fenster_loop) Décor: <input type="checkbox"/> = without <input type="checkbox"/> = on both sides <input type="checkbox"/> = outside <input type="checkbox"/> = inside						
Illustration	Description	Article no.	Length / PU	Colour main body+colour gasket	Pattern	From page
	Threshold holder set	<b>ZS7845</b>	75 pc. / carton	Grey	-	<a href="#">Chapter 3</a> <a href="#">Page 119</a>
	Rebate seal part set	<b>ZS7890</b>	50 pairs	Black	-	<a href="#">Chapter 3</a> <a href="#">Page 121</a>
<b>Widenings</b>						
	Door threshold extension	<b>NP1120</b>	6 m	PW; SW	<input type="checkbox"/>   <input type="checkbox"/>   <input type="checkbox"/>   <input type="checkbox"/>	<a href="#">Chapter 3</a> <a href="#">Page 128</a>
	Door threshold extension	<b>NP1350</b>	6 m	PW; SW	<input type="checkbox"/>   <input type="checkbox"/>   <input type="checkbox"/>   <input type="checkbox"/>	<a href="#">Chapter 3</a> <a href="#">Page 128</a>
	Door threshold extension	<b>NP1550</b>	6 m	PW; SW	<input type="checkbox"/>   <input type="checkbox"/>   <input type="checkbox"/>   <input type="checkbox"/>	<a href="#">Chapter 3</a> <a href="#">Page 129</a>
	Base profile	<b>NP3280</b>	6 m	PW; SW	<input type="checkbox"/>   <input type="checkbox"/>   <input type="checkbox"/>   <input type="checkbox"/>	<a href="#">Chapter 3</a> <a href="#">Page 126</a>
	Widening	<b>NP3300</b>	6 m	PW; SW	<input type="checkbox"/>   <input type="checkbox"/>   <input type="checkbox"/>   <input type="checkbox"/>	<a href="#">Chapter 3</a> <a href="#">Page 125</a>



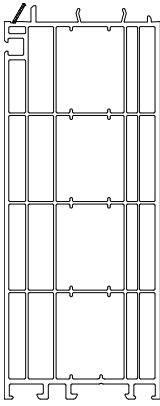
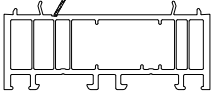
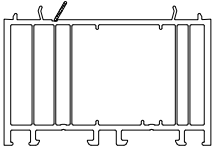
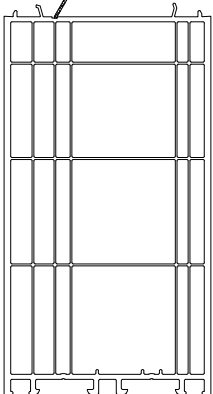
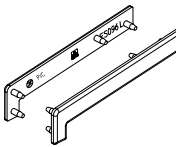
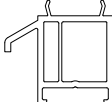

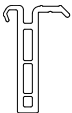
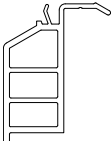
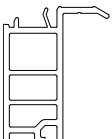
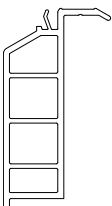
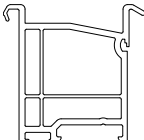
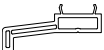
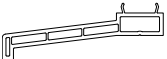
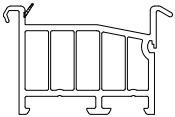
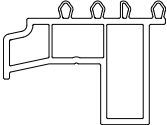
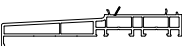

## Side profiles and accessories

Colour base body: PW = pureWhite; CA = caramel; BR = brown; AN = anthracite, CR = cream; GL = Greta@Fenster_loop SW = solidWhite Colour seal: s = black; g = grey; l = light grey (suitable with Greta@Fenster_loop) Décor: <input type="checkbox"/> = without <input type="checkbox"/> = on both sides <input type="checkbox"/> = outside <input type="checkbox"/> = inside						
Illustration	Description	Article no.	Length / PU	Colour main body+colour gasket	Pattern	From page
	Widening	<b>NP8200</b>	6 m	PW; SW	<input type="checkbox"/>   <input type="checkbox"/>   <input type="checkbox"/>   <input type="checkbox"/>	<a href="#">Chapter 3</a> <a href="#">Page 122</a>
	Base profile	<b>NP8280</b>	6.5 m	PW; SW	<input type="checkbox"/>   <input type="checkbox"/>   <input type="checkbox"/>   <input type="checkbox"/>	<a href="#">Chapter 3</a> <a href="#">Page 127</a>
	Door threshold extension	<b>NP8300</b>	6 m	PW; SW	<input type="checkbox"/>   <input type="checkbox"/>   <input type="checkbox"/>   <input type="checkbox"/>	<a href="#">Chapter 3</a> <a href="#">Page 122</a>
	Door threshold extension	<b>NP8500</b>	6 m	PW; SW	<input type="checkbox"/>   <input type="checkbox"/>   <input type="checkbox"/>   <input type="checkbox"/>	<a href="#">Chapter 3</a> <a href="#">Page 123</a>
	Door threshold extension	<b>NP8700</b>	6 m	PW; SW	<input type="checkbox"/>   <input type="checkbox"/>   <input type="checkbox"/>   <input type="checkbox"/>	<a href="#">Chapter 3</a> <a href="#">Page 124</a>
<b>Sill connection</b>						
	End caps	<b>ES0960</b>	20 pc.	SW; BR	-	<a href="#">Chapter 3</a> <a href="#">Page 132</a>
	External sill connection	<b>NP0300</b>	6 m	SW	-	<a href="#">Chapter 3</a> <a href="#">Page 130</a>

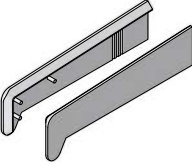

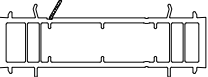
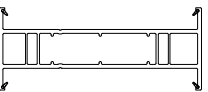
Side profiles and accessories

Colour base body: PW = pureWhite; CA = caramel; BR = brown; AN = anthracite, CR = cream; GL = Greta@Fenster_loop SW = solidWhite Colour seal: s = black; g = grey; l = light grey (suitable with Greta@Fenster_loop) Décor: <input type="checkbox"/> = without <input type="checkbox"/> = on both sides <input type="checkbox"/> = outside <input type="checkbox"/> = inside						
Illustration	Description	Article no.	Length / PU	Colour main body+colour gasket	Pattern	From page
	External sill connection	<b>NP0320</b>	6 m	SW	-	<a href="#">Chapter 3</a> <a href="#">Page 130</a>
	External sill connection	<b>NP0360</b>	6 m	SW	-	<a href="#">Chapter 3</a> <a href="#">Page 130</a>
	External sill connection	<b>NP0370</b>	6 m	SW	-	<a href="#">Chapter 3</a> <a href="#">Page 130</a>
	External sill connection	<b>NP0380</b>	6 m	SW	-	<a href="#">Chapter 3</a> <a href="#">Page 130</a>
	External sill connection	<b>NP0400</b>	6 m	SW	-	<a href="#">Chapter 3</a> <a href="#">Page 130</a>
	Window sill connection	<b>NP0770</b>	6 m	SW	<input type="checkbox"/>   <input type="checkbox"/>   <input type="checkbox"/>   <input type="checkbox"/>	<a href="#">Chapter 3</a> <a href="#">Page 132</a>
	Window sill connection	<b>NP0960</b>	6 m	SW	<input type="checkbox"/>   <input type="checkbox"/>   <input type="checkbox"/>   <input type="checkbox"/>	<a href="#">Chapter 3</a> <a href="#">Page 132</a>
	External sill connection	<b>NP8020</b>	6 m	Colourful	-	<a href="#">Chapter 3</a> <a href="#">Page 130</a>
	External sill connection	<b>416119</b>	6 m	Black	-	<a href="#">Chapter 3</a> <a href="#">Page 130</a>
<b>Window sills</b>						
	Window sill connection	<b>NP0850</b>	6 m	PW; BR	<input type="checkbox"/>   <input type="checkbox"/>   <input type="checkbox"/>   <input type="checkbox"/>	<a href="#">Chapter 3</a> <a href="#">Page 133</a>

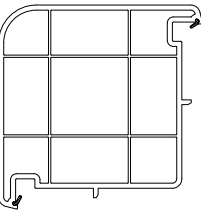
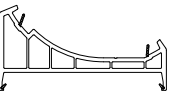
## Side profiles and accessories

Colour base body:		PW = pureWhite; CA = caramel; BR = brown; AN = anthracite, CR = cream; GL = Greta@Fenster_loop SW = solidWhite				
Colour seal:		s = black; g = grey; l = light grey (suitable with Greta@Fenster_loop)				
Décor:		<input type="checkbox"/> = without	<input type="checkbox"/> = on both sides	<input type="checkbox"/> = outside	<input type="checkbox"/> = inside	
Illustration	Description	Article no.	Length / PU	Colour main body+colour gasket	Pattern	From page
	End caps	<b>417115</b>	50 pairs	PW; BR; CA	-	<a href="#">Chapter 3</a> <a href="#">Page 133</a>
<b>Couplings</b>						
	Coupling profile	<b>NP0190</b>	6 m	SW	<input type="checkbox"/> <input type="checkbox"/>	<a href="#">Chapter 3</a> <a href="#">Page 134</a>
	Coupling profile	<b>NP8110</b>	6 m	SW	<input type="checkbox"/> <input type="checkbox"/> <input type="checkbox"/> <input type="checkbox"/>	<a href="#">Chapter 3</a> <a href="#">Page 134</a>
	Coupling profile	<b>NP8120</b>	6 m	SW	<input type="checkbox"/> <input type="checkbox"/> <input type="checkbox"/> <input type="checkbox"/>	<a href="#">Chapter 3</a> <a href="#">Page 134</a>
	Coupling profile	<b>NP8170</b>	6 m	SW	<input type="checkbox"/> <input type="checkbox"/> <input type="checkbox"/> <input type="checkbox"/>	<a href="#">Chapter 3</a> <a href="#">Page 134</a>
<b>Static couplings</b>						
	Spacer	<b>MT8140</b>	100 pc.	White	-	<a href="#">Chapter 3</a> <a href="#">Page 135</a>
	Coupling profile	<b>NP8140</b>	6 m	PW	-	<a href="#">Chapter 3</a> <a href="#">Page 135</a>
	Coupling steel	<b>VS8140</b>	6 m	Steel, galvanised	-	<a href="#">Chapter 3</a> <a href="#">Page 135</a>
	Cover profile	<b>ZF2110</b>	Upon request	PW	<input type="checkbox"/> <input type="checkbox"/>	<a href="#">Chapter 3</a> <a href="#">Page 135</a>
<b>Corner connections</b>						
	Corner connection, 90°	<b>NP0100</b>	6 m	SW; BR	<input type="checkbox"/> <input type="checkbox"/> <input type="checkbox"/> <input type="checkbox"/>	<a href="#">Chapter 3</a> <a href="#">Page 136</a>
	Adapter	<b>NP8150</b>	6 m	SW; BR	<input type="checkbox"/> <input type="checkbox"/> <input type="checkbox"/> <input type="checkbox"/>	<a href="#">Chapter 3</a> <a href="#">Page 138</a>

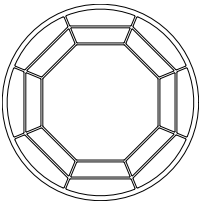
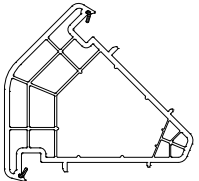
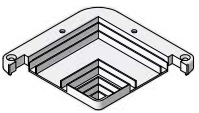
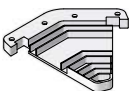
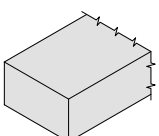
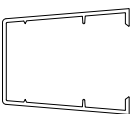
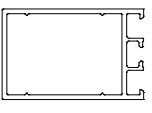

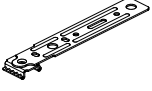







Side profiles and accessories

Colour base body: PW = pureWhite; CA = caramel; BR = brown; AN = anthracite, CR = cream; GL = Greta@Fenster_loop SW = solidWhite Colour seal: s = black; g = grey; l = light grey (suitable with Greta@Fenster_loop) Décor: <input type="checkbox"/> = without <input type="checkbox"/> = on both sides <input type="checkbox"/> = outside <input type="checkbox"/> = inside						
Illustration	Description	Article no.	Length / PU	Colour main body+colour gasket	Pattern	From page
	Corner connection, variable	<b>NP8160</b>	6 m	SW; BR	<input type="checkbox"/>   <input type="checkbox"/>   <input type="checkbox"/>   <input type="checkbox"/>	<a href="#">Chapter 3</a> <a href="#">Page 138</a>
	Corner connection, 135°	<b>416240</b>	6 m	SW; BR	<input type="checkbox"/>   <input type="checkbox"/>   <input type="checkbox"/>   <input type="checkbox"/>	<a href="#">Chapter 3</a> <a href="#">Page 137</a>
	End cap	<b>417210</b>	30 pc.	PW; BR; black; grey	-	<a href="#">Chapter 3</a> <a href="#">Page 136</a>
	End cap	<b>417240</b>	30 pc.	PW; BR	-	<a href="#">Chapter 3</a> <a href="#">Page 137</a>
	Insulation strip	<b>417810</b>	1 m / 100 pc.	-	-	<a href="#">Chapter 3</a> <a href="#">Page 136</a>
<b>Static profiles (pilaster strips)</b>						
	Attachment frame	<b>406271</b>	6.5 m	PW; SW	<input type="checkbox"/>   <input type="checkbox"/>	<a href="#">Chapter 3</a> <a href="#">Page 139</a>
	Sheathing profile	<b>416269</b>	6 m	PW; BR	<input type="checkbox"/>   <input type="checkbox"/>	<a href="#">Chapter 3</a> <a href="#">Page 140</a>
	Cover profile	<b>416311</b>	6 m	PW; BR	<input type="checkbox"/>   <input type="checkbox"/>	<a href="#">Chapter 3</a> <a href="#">Page 140</a>
<b>Fixings</b>						
	Wall anchor	<b>MT1000</b>	250 pc.	Steel, galvanised	-	<a href="#">Chapter 3</a> <a href="#">Page 141</a>



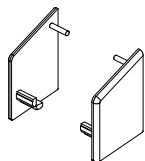

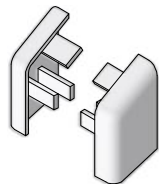

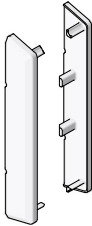

## Side profiles and accessories

Colour base body: PW = pureWhite; CA = caramel; BR = brown; AN = anthracite, CR = cream; GL = Greta@Fenster_loop SW = solidWhite Colour seal: s = black; g = grey; l = light grey (suitable with Greta@Fenster_loop) Décor: <input type="checkbox"/> = without <input type="checkbox"/> = on both sides <input type="checkbox"/> = outside <input type="checkbox"/> = inside						
Illustration	Description	Article no.	Length / PU	Colour main body+colour gasket	Pattern	From page
	Wall anchor	<b>MT1010</b>	250 pc.	Steel, galvanised	-	<a href="#">Chapter 3</a> <a href="#">Page 141</a>
	Wall anchor	<b>MT1040</b>	250 pc.	Steel, galvanised	-	<a href="#">Chapter 3</a> <a href="#">Page 141</a>
	Fixed iron	<b>407570</b>	1 pc.	Steel, galvanised	-	<a href="#">Chapter 3</a> <a href="#">Page 142</a>
	Fixed iron	<b>407571</b>	1 pc.	Steel, galvanised	-	<a href="#">Chapter 3</a> <a href="#">Page 142</a>
	Rebate corner angle	<b>438566</b>	20 pc.	Titanium-silver	-	<a href="#">Chapter 3</a> <a href="#">Page 142</a>



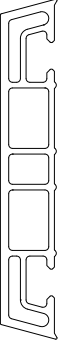

Side profiles and accessories

Colour base body: PW = pureWhite; CA = caramel; BR = brown; AN = anthracite, CR = cream; GL = Greta@Fenster_loop SW = solidWhite Colour seal: s = black; g = grey; l = light grey (suitable with Greta@Fenster_loop) Décor: <input type="checkbox"/> = without <input type="checkbox"/> = on both sides <input type="checkbox"/> = outside <input type="checkbox"/> = inside						
Illustration	Description	Article no.	Length / PU	Colour main body+colour gasket	Pattern	From page
<b>Glazing bars, self-adhesive</b>						
	Glazing bar, self-adhesive	<b>416302</b>	5 m	PW+s; PW+g; SW+s; SW+g; BR+s	<input type="checkbox"/> <input type="checkbox"/>	<a href="#">Chapter 3</a> <a href="#">Page 143</a>
	Glazing bar, self-adhesive	<b>416304</b>	5 m	PW+s; PW+g; SW+s; SW+g; BR+s	<input type="checkbox"/> <input type="checkbox"/>	<a href="#">Chapter 3</a> <a href="#">Page 143</a>
	Glazing bar, self-adhesive	<b>416306</b>	5 m	PW+s; PW+g; SW+s; SW+g; BR+s	-	<a href="#">Chapter 3</a> <a href="#">Page 143</a>
	Glazing bar, self-adhesive	<b>416322</b>	5 m	PW+s; PW+g; SW+s; SW+g; BR+s	<input type="checkbox"/> <input type="checkbox"/>	<a href="#">Chapter 3</a> <a href="#">Page 143</a>
	Glazing bar, self-adhesive	<b>416324</b>	5 m	PW+s; PW+g; SW+s	<input type="checkbox"/> <input type="checkbox"/>	<a href="#">Chapter 3</a> <a href="#">Page 143</a>
	Glazing bar, self-adhesive	<b>416326</b>	5 m	PW+s; PW+g; SW+s	<input type="checkbox"/> <input type="checkbox"/>	<a href="#">Chapter 3</a> <a href="#">Page 143</a>
<b>Weather profile strip</b>						
	End caps	<b>ES0220</b>	200 pc.	Black	-	<a href="#">Chapter 3</a> <a href="#">Page 144</a>
	Weather profile strip	<b>NP0220</b>	6 m	PW; CA	<input type="checkbox"/>   <input type="checkbox"/>	<a href="#">Chapter 3</a> <a href="#">Page 144</a>
	End caps	<b>SG1940</b>	200 pc.	PW; CA; BR	-	<a href="#">Chapter 3</a> <a href="#">Page 144</a>
	Weather profile strip	<b>ZF1940</b>	6 m	PW; CA; BR	<input type="checkbox"/>   <input type="checkbox"/>	<a href="#">Chapter 3</a> <a href="#">Page 144</a>

## Side profiles and accessories

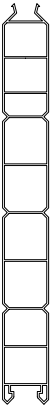
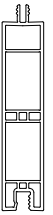
Colour base body: PW = pureWhite; CA = caramel; BR = brown; AN = anthracite, CR = cream; GL = Greta@Fenster_loop SW = solidWhite Colour seal: s = black; g = grey; l = light grey (suitable with Greta@Fenster_loop) Décor: <input type="checkbox"/> = without <input type="checkbox"/> = on both sides <input type="checkbox"/> = outside <input type="checkbox"/> = inside						
Illustration	Description	Article no.	Length / PU	Colour main body+colour gasket	Pattern	From page
<b>Cladding profiles</b>						
	End caps	<b>ES8250</b>	50 pc.	White; Caramel; Brown	-	<a href="#">Chapter 3</a> <a href="#">Page 150</a>
	Cover profile	<b>NP8180</b>	6 m	SW; light grey	-	<a href="#">Chapter 3</a> <a href="#">Page 148</a>
	Inner strike plate	<b>NP8250</b>	6 m	PW; CA; BR	<input type="checkbox"/> <input type="checkbox"/>	<a href="#">Chapter 3</a> <a href="#">Page 150</a>
	Cover, lateral	<b>NP8270</b>	6 m	SW; colourful	-	<a href="#">Chapter 3</a> <a href="#">Page 148</a>
	Flat profile	<b>ZF0510</b>	6 m	PW; SW	-	<a href="#">Chapter 3</a> <a href="#">Page 151</a>
	Cover profile	<b>ZF1910</b>	6.5 m	PW; SW	-	<a href="#">Chapter 3</a> <a href="#">Page 149</a>
	Corner-bracket	<b>406319</b>	6 m	PW; BR	<input type="checkbox"/> <input type="checkbox"/> <input type="checkbox"/>	<a href="#">Chapter 3</a> <a href="#">Page 151</a>
	Corner-bracket	<b>406320</b>	6 m	PW; BR	<input type="checkbox"/> <input type="checkbox"/>	<a href="#">Chapter 3</a> <a href="#">Page 151</a>
	Cover	<b>406340</b>	6 m	PW; BR	<input type="checkbox"/> <input type="checkbox"/>	<a href="#">Chapter 3</a> <a href="#">Page 149</a>

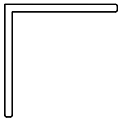
Side profiles and accessories

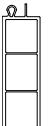
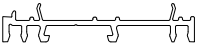
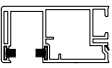
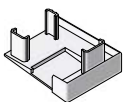
Colour base body: PW = pureWhite; CA = caramel; BR = brown; AN = anthracite, CR = cream; GL = Greta@Fenster_loop SW = solidWhite Colour seal: s = black; g = grey; l = light grey (suitable with Greta@Fenster_loop) Décor: <input type="checkbox"/> = without <input type="checkbox"/> = on both sides <input type="checkbox"/> = outside <input type="checkbox"/> = inside						
Illustration	Description	Article no.	Length / PU	Colour main body+colour gasket	Pattern	From page
	Panel profile	<b>406670</b>	6 m	PW; BR	<input type="checkbox"/>   <input type="checkbox"/>   <input type="checkbox"/>	<a href="#">Chapter 3</a> <a href="#">Page 146</a>
	Filling panel	<b>416274</b>	6 m	PW	Upon request	<a href="#">Chapter 3</a> <a href="#">Page 146</a>
	Cover profile, self-adhesive	<b>416327</b>	6 m	PW; BR	<input type="checkbox"/> <input type="checkbox"/>	<a href="#">Chapter 3</a> <a href="#">Page 147</a>
	Corner-bracket	<b>416330</b>	6 m	Black-brown	<input type="checkbox"/> <input type="checkbox"/>	<a href="#">Chapter 3</a> <a href="#">Page 151</a>
	Cover profile, self-adhesive	<b>416337</b>	6 m	PW; BR	<input type="checkbox"/> <input type="checkbox"/>	<a href="#">Chapter 3</a> <a href="#">Page 147</a>
	Cover profile, self-adhesive	<b>416357</b>	6 m	PW; BR	<input type="checkbox"/> <input type="checkbox"/>	<a href="#">Chapter 3</a> <a href="#">Page 147</a>
	Cover strip	<b>416360</b>	6 m	PW; BR	<input type="checkbox"/>   <input type="checkbox"/>	<a href="#">Chapter 3</a> <a href="#">Page 146</a>
	Adapter profile	<b>416382</b>	6.5 m	PW	<input type="checkbox"/>   <input type="checkbox"/>   <input type="checkbox"/> <input type="checkbox"/>	<a href="#">Chapter 3</a> <a href="#">Page 148</a>
	Tapee	<b>416386</b>	6 m	PW; BR	<input type="checkbox"/>   <input type="checkbox"/>	<a href="#">Chapter 3</a> <a href="#">Page 145</a>
<b>Roller shutter accessories</b>						
	End cap	<b>ES0530</b>	50 pairs	SW	-	<a href="#">Chapter 3</a> <a href="#">Page 153</a>



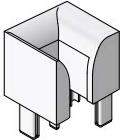
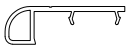
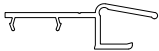
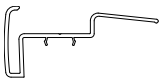
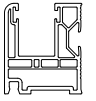
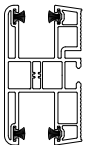
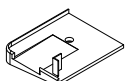
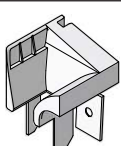
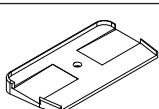
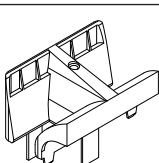
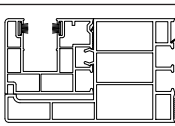



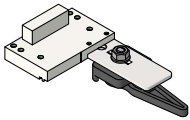
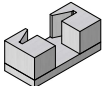
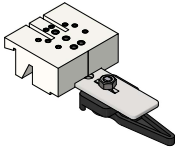
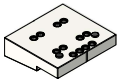

## Side profiles and accessories

Colour base body:		PW = pureWhite; CA = caramel; BR = brown; AN = anthracite, CR = cream; GL = Greta@Fenster_loop SW = solidWhite					
Colour seal:		s = black; g = grey; l = light grey (suitable with Greta@Fenster_loop)					
Décor:		□ = without		□  = on both sides		□ = outside	□  = inside
Illustration	Description	Article no.	Length / PU	Colour main body+colour gasket	Pattern	From page	
	Roller shutter guide	<b>RF0530</b>	6 m	SW	□  □	<a href="#">Chapter 3</a> <a href="#">Page 153</a>	
	Inlet funnel	<b>RZ1420</b>	50 pairs	SW	-	<a href="#">Chapter 3</a> <a href="#">Page 153</a>	
	Roller shutter drain	<b>RF3200</b>	6 m	PW; BR	-	<a href="#">Chapter 3</a> <a href="#">Page 152</a>	
	Roller shutter floor connection	<b>RF3210</b>	6 m	SW	-	<a href="#">Chapter 3</a> <a href="#">Page 152</a>	
	Roller shutter drain	<b>RF3220</b>	6 m	SW	-	<a href="#">Chapter 3</a> <a href="#">Page 152</a>	
	Roller shutter guide	<b>416086</b>	6 m	PW; CA; BR	□  □	<a href="#">Chapter 3</a> <a href="#">Page 155</a>	
	Double roller shutter guide	<b>416096</b>	6 m	PW; CA; BR	□  □	<a href="#">Chapter 3</a> <a href="#">Page 156</a>	
	End cap	<b>417081</b>	50 pairs	White; Caramel; Brown	-	<a href="#">Chapter 3</a> <a href="#">Page 155</a>	
	Inlet funnel	<b>417082</b>	50 pairs	PW; CA; BR	-	<a href="#">Chapter 3</a> <a href="#">Page 155</a>	
	End cap	<b>417095</b>	30 pc.	White; Caramel; Brown	-	Roller shutter guide	
	Inlet funnel	<b>417096</b>	30 pc.	PW; BR	-	Roller shutter guide	
	Adapter profile with roller shutter guide and brush	<b>556070</b>	6.5 m	PW; SW; BR	□  □	<a href="#">Chapter 3</a> <a href="#">Page 154</a>	

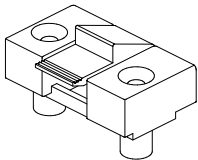





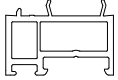



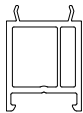

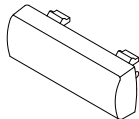
Side profiles and accessories

Colour base body: PW = pureWhite; CA = caramel; BR = brown; AN = anthracite, CR = cream; GL = Greta@Fenster_loop SW = solidWhite Colour seal: s = black; g = grey; l = light grey (suitable with Greta@Fenster_loop) Décor: <input type="checkbox"/> = without <input type="checkbox"/> = on both sides <input type="checkbox"/> = outside <input type="checkbox"/> = inside						
Illustration	Description	Article no.	Length / PU	Colour main body+colour gasket	Pattern	From page
	Roll-off profile	<b>556075</b>	6 m	SW	-	<a href="#">Chapter 3</a> <a href="#">Page 154</a>
	Inlet funnel	<b>557170</b>	50 pairs	PW; BR	-	<a href="#">Chapter 3</a> <a href="#">Page 154</a>
<b>Panels</b>						
	PVC panel	<b>PM1320</b>	1 pc.	White	-	<a href="#">Chapter 3</a> <a href="#">Page 157</a>
	Laminate board	<b>407914</b>	1 pc.	PW; BR	<input type="checkbox"/> <input type="checkbox"/>	<a href="#">Chapter 3</a> <a href="#">Page 157</a>
	Sandwich panel	<b>407920</b>	1 pc.	PW; CR	<input type="checkbox"/>   <input type="checkbox"/>   <input type="checkbox"/>	<a href="#">Chapter 3</a> <a href="#">Page 157</a>
<b>Drilling and cutting jigs</b>						
	Drilling jig for threshold	<b>MT7130</b>	1 pc.	-	-	<a href="#">Chapter 3</a> <a href="#">Page 158</a>
	Drilling jig for threshold, door opening outwards	<b>MT7125</b>	1 pc.	-	-	<a href="#">Chapter 3</a> <a href="#">Page 158</a>
	Drilling and cutting jig	<b>MT9900</b>	1 pc.	-	-	<a href="#">Chapter 3</a> <a href="#">Page 158</a>
	Drilling and cutting jig	<b>MT9901</b>	1 pc.	-	-	<a href="#">Chapter 3</a> <a href="#">Page 158</a>

## Side profiles and accessories

Colour base body:		PW = pureWhite; CA = caramel; BR = brown; AN = anthracite, CR = cream; GL = Greta@Fenster_loop SW = solidWhite					
Colour seal:		s = black; g = grey; l = light grey (suitable with Greta@Fenster_loop)					
Décor:		□ = without		□  = on both sides		□ = outside	□  = inside
Illustration	Description	Article no.	Length / PU	Colour main body+colour gasket	Pattern	From page	
	Drilling jig	<b>MT9902</b>	1 pc.	-	-	<a href="#">Chapter 3</a> <a href="#">Page 158</a>	
	Cutting jig	<b>MT9910</b>	1 pc.	-	-	<a href="#">Chapter 3</a> <a href="#">Page 158</a>	
	Drilling and cutting jig	<b>MT9920</b>	1 pc.	-	-	<a href="#">Chapter 3</a> <a href="#">Page 158</a>	
	Drilling jig	<b>MT9940</b>	1 pc.	-	-	<a href="#">Chapter 3</a> <a href="#">Page 158</a>	
<b>Miscellaneous accessories</b>							
	Sash-supporter component	<b>ES1000</b>	100 pc.	Upon request	-	<a href="#">Chapter 3</a> <a href="#">Page 163</a>	
	Fixed glazing clip	<b>ES1010</b>	50 pc.	White	-	<a href="#">Chapter 3</a> <a href="#">Page 163</a>	
	Sealing piece	<b>ES1500</b>	20 pc.	Black	-	<a href="#">Chapter 3</a> <a href="#">Page 163</a>	
	Snap-in head screw	<b>MZ1200</b>	500 pc.	Galvanised	-	<a href="#">Chapter 3</a> <a href="#">Page 149</a>	
	Cover cap	<b>MZ2880</b>	1000 pc.	White; brown	-	<a href="#">Chapter 3</a> <a href="#">Page 163</a>	
	Beading	<b>NP0060</b>	300 m	White; caramel; grey; brown	-	<a href="#">Chapter 3</a> <a href="#">Page 163</a>	
	Beading	<b>NP8000</b>	300 m	White; Caramel; Brown	-	<a href="#">Chapter 3</a> <a href="#">Page 163</a>	
	Additional profile	<b>NP0200</b>	6 m	White; brown	-	<a href="#">Chapter 3</a> <a href="#">Page 162</a>	

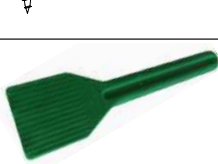
Side profiles and accessories

Colour base body: PW = pureWhite; CA = caramel; BR = brown; AN = anthracite, CR = cream; GL = Greta@Fenster_loop SW = solidWhite Colour seal: s = black; g = grey; l = light grey (suitable with Greta@Fenster_loop) Décor: <input type="checkbox"/> = without <input type="checkbox"/> = on both sides <input type="checkbox"/> = outside <input type="checkbox"/> = inside						
Illustration	Description	Article no.	Length / PU	Colour main body+colour gasket	Pattern	From page
	Transport protection	<b>NP0310</b>	6 m	Colourful	-	<a href="#">Chapter 3</a> <a href="#">Page 162</a>
	Clamp-strip for ZF1940	<b>NP1940</b>	6 m	Colourful	-	<a href="#">Chapter 3</a> <a href="#">Page 144</a>
	Wind cap	<b>SG3400</b>			-	<a href="#">Chapter 3</a> <a href="#">Page 163</a>
	Kick plate	<b>VA1010</b>	6 m	Aluminium	-	<a href="#">Chapter 3</a> <a href="#">Page 162</a>
	Kick plate	<b>VA8100</b>	6 m	Aluminium	-	<a href="#">Chapter 3</a> <a href="#">Page 162</a>
	Kick plate	<b>VA8110</b>	6 m	Aluminium	-	<a href="#">Chapter 3</a> <a href="#">Page 162</a>
	Clamp-strip PVC	<b>406335</b>	30 m	Colourful	-	<a href="#">Chapter 3</a> <a href="#">Page 149</a>
	Clamp-strip aluminium	<b>406635</b>	6 m	Aluminium	-	<a href="#">Chapter 3</a> <a href="#">Page 149</a>
	Snap-in head screw	<b>407900</b>	1000 pc.	Galvanised	-	<a href="#">Chapter 3</a> <a href="#">Page 149</a> <a href="#">Chapter 3</a> <a href="#">Page 150</a>
	Snap-in head screw	<b>407965</b>	500 pc.	Galvanised	-	<a href="#">Chapter 3</a> <a href="#">Page 145</a>
	Block trowel for block bridges and glass blocks	<b>407290</b>	1 pc.	-	-	-
<b>Maintenance, care and preservation of value</b>						
	APTK adhesive for white profiles	<b>407710</b>	1 pc.	-	-	-
	Adhesive Fenoplast KF for white profiles	<b>407720-000 edition</b>	1 pc.	-	-	-



## Side profiles and accessories

Colour base body: PW = pureWhite; CA = caramel; BR = brown; AN = anthracite, CR = cream; GL = Greta@Fenster_loop SW = solidWhite Colour seal: s = black; g = grey; l = light grey (suitable with Greta@Fenster_loop) Décor: <input type="checkbox"/> = without <input type="checkbox"/> = on both sides <input type="checkbox"/> = outside <input type="checkbox"/> = inside						
Illustration	Description	Article no.	Length / PU	Colour main body+colour gasket	Pattern	From page
	Adhesive: Fenoplast PMMA for decorative profiles	<b>407725-000</b>	1 pc.	-	-	-
	Adhesive: Fenoplast PMMA for white profiles	<b>407730-000</b>	1 pc.	-	-	-
	Cleaning agent, very weak solvent	<b>407810</b>	1 pc.	-	-	-
	Cleaning agent non-soluble	<b>407830</b>	1 pc.	-	-	-
	Smoothing and polishing agent, highly soluble	<b>407840</b>	1 pc.	-	-	-
	Repair resin SIP	<b>407852</b>	1 set	-	-	-
	Spray paint for floating-mullion end cover caps	<b>407875</b>	1 pc.	-	-	-
	Touch-up stick (Edge Fix)	<b>407880</b>	1 pc.	-	-	-

Side profiles and accessories

Colour base body: PW = pureWhite; CA = caramel; BR = brown; AN = anthracite, CR = cream; GL = Greta@Fenster_loop Colour seal: s = black; g = grey; l = light grey (suitable with Greta@Fenster_loop) Décor: <input type="checkbox"/> = without <input type="checkbox"/> = on both sides <input type="checkbox"/> = outside <input type="checkbox"/> = inside						
Illustration	Description	Article no.	Length / PU	Colour main body+colour gasket	Pattern	From page
	Cleaning and care set	<b>407890-000</b>	1 set	-	-	-
	Cleaning and care set	<b>407890-007</b>	1 set	-	-	-
	Care set for laminated profiles SIP	<b>407895</b>	1 set	-	-	-
	Repair set	<b>417851</b>	1 set	-	-	-
	Clear lacquer	<b>417887</b>	1 pc.	-	-	-
	Top-Clean cleaning agent	<b>MZ2850</b>	1 pc.	-	-	-

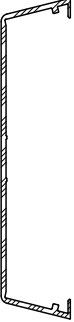
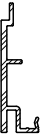
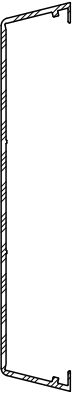
## Aluminium clip facing shells

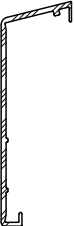
Colour base body: PW = pureWhite; CA = caramel; BR = brown; AN = anthracite, CR = cream; GL = Greta@Fenster_loop SW = solidWhite Colour seal: s = black; g = grey; l = light grey (suitable with Greta@Fenster_loop) Décor: <input type="checkbox"/> = without <input type="checkbox"/> = on both sides <input type="checkbox"/> = outside <input type="checkbox"/> = inside						
Illustration	Description	Article no.	Length / PU	Colour main body+colour gasket	Pattern	From page
<b>Aluminium clip facing shells</b>						
	Aluminium clip facing shell	<b>VA8302</b>	Upon request	-	-	<a href="#">Chapter 3</a> <a href="#">Page 172</a>
	Aluminium clip facing shell	<b>VA8303</b>	Upon request	-	-	<a href="#">Chapter 3</a> <a href="#">Page 175</a>
	Aluminium clip facing shell	<b>VA8312</b>	Upon request	-	-	<a href="#">Chapter 3</a> <a href="#">Page 170</a>
	Aluminium clip facing shell	<b>VA8503</b>	Upon request	-	-	<a href="#">Chapter 3</a> <a href="#">Page 175</a>
	Aluminium clip facing shell	<b>VA8523</b>	Upon request	-	-	<a href="#">Chapter 3</a> <a href="#">Page 167</a>



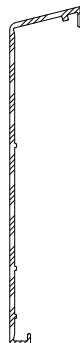
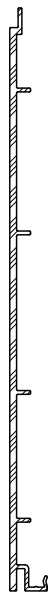
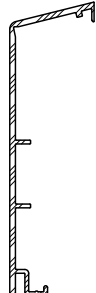

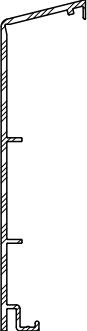
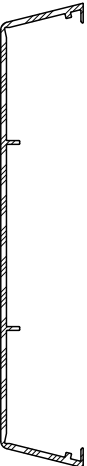
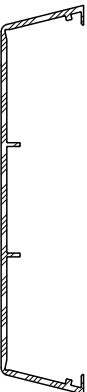

Aluminium clip facing shells

Colour base body: PW = pureWhite; CA = caramel; BR = brown; AN = anthracite, CR = cream; GL = Greta@Fenster_loop SW = solidWhite Colour seal: s = black; g = grey; l = light grey (suitable with Greta@Fenster_loop) Décor: <input type="checkbox"/> = without <input type="checkbox"/> = on both sides <input type="checkbox"/> = outside <input type="checkbox"/> = inside						
Illustration	Description	Article no.	Length / PU	Colour main body+colour gasket	Pattern	From page
	Aluminium clip facing shell	<b>VA8532</b>	Upon request	-	-	<a href="#">Chapter 3</a> <a href="#">Page 168</a>
	Aluminium clip facing shell	<b>VA8703</b>	Upon request	-	-	<a href="#">Chapter 3</a> <a href="#">Page 176</a>
	Aluminium clip facing shell	<b>VA9022</b>	Upon request	-	-	<a href="#">Chapter 3</a> <a href="#">Page 164</a>

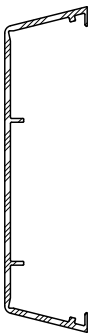
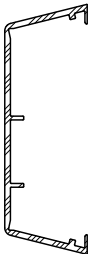
Aluminium clip facing shells

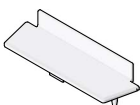
Colour base body: PW = pureWhite; CA = caramel; BR = brown; AN = anthracite, CR = cream; GL = Greta@Fenster_loop SW = solidWhite Colour seal: s = black; g = grey; l = light grey (suitable with Greta@Fenster_loop) Décor: <input type="checkbox"/> = without <input type="checkbox"/> = on both sides <input type="checkbox"/> = outside <input type="checkbox"/> = inside						
Illustration	Description	Article no.	Length / PU	Colour main body+colour gasket	Pattern	From page
	Aluminium clip facing shell	<b>VA9032</b>	Upon request	-	-	<a href="#">Chapter 3</a> <a href="#">Page 166</a>
	Aluminium clip facing shell	<b>VA9342</b>	Upon request	-	-	<a href="#">Chapter 3</a> <a href="#">Page 171</a>
	Aluminium clip facing shell	<b>VA9322</b>	Upon request	-	-	<a href="#">Chapter 3</a> <a href="#">Page 169</a>

Aluminium clip facing shells

Colour base body: PW = pureWhite; CA = caramel; BR = brown; AN = anthracite, CR = cream; GL = Greta@Fenster_loop SW = solidWhite Colour seal: s = black; g = grey; l = light grey (suitable with Greta@Fenster_loop) Décor: <input type="checkbox"/> = without <input type="checkbox"/> = on both sides <input type="checkbox"/> = outside <input type="checkbox"/> = inside						
Illustration	Description	Article no.	Length / PU	Colour main body+colour gasket	Pattern	From page
	Aluminium clip facing shell	<b>VA9802</b>	Upon request	-	-	<a href="#">Chapter 3</a> <a href="#">Page 174</a>
	Aluminium clip facing shell	<b>VA9812</b>	Upon request	-	-	<a href="#">Chapter 3</a> <a href="#">Page 173</a>
<b>Gaskets</b>						
	Stopper gasket	<b>DP2720</b>	100 m	Black, grey	-	<a href="#">Chapter 3</a> <a href="#">Page 178</a>
	Glazing gasket	<b>DP2730</b>	100 m	Black, grey	-	<a href="#">Chapter 3</a> <a href="#">Page 178</a>
<b>Accessories</b>						
	Floating-mullion end cover cap	<b>ES9812</b>	50 pc.	White; Cream; Caramel; Brown; Black	-	<a href="#">Chapter 3</a> <a href="#">Page 174</a>
	Floating-mullion end cover cap	<b>ES9832</b>	50 pc.	White; Cream; Caramel; Brown; Black	-	<a href="#">Chapter 3</a> <a href="#">Page 173</a>
	Distance compensation	<b>MT9080</b>	1000 pc.	Black	-	<a href="#">Chapter 3</a> <a href="#">Page 178</a>
	Aluminium sheet	<b>VA9400</b>	Upon request	-	-	<a href="#">Chapter 3</a> <a href="#">Page 177</a>
	Aluminium T-profile	<b>VA9410</b>	Upon request	-	-	<a href="#">Chapter 3</a> <a href="#">Page 177</a>

Aluminium clip facing shells

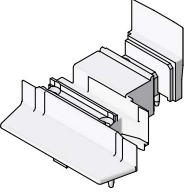
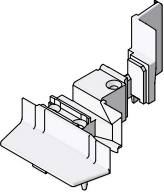
Colour base body: PW = pureWhite; CA = caramel; BR = brown; AN = anthracite, CR = cream; GL = Greta@Fenster_loop SW = solidWhite Colour seal: s = black; g = grey; l = light grey (suitable with Greta@Fenster_loop) Décor: <input type="checkbox"/> = without <input type="checkbox"/> = on both sides <input type="checkbox"/> = outside <input type="checkbox"/> = inside						
Illustration	Description	Article no.	Length / PU	Colour main body+colour gasket	Pattern	From page
	Faceplate end cover cap set	<b>ZS9802</b>	50 pc.	White; Cream; Caramel; Brown; Black	-	<a href="#">Chapter 3</a> <a href="#">Page 173</a>
	Faceplate end cover cap set	<b>ZS9812</b>	50 pc.	White; Cream; Caramel; Brown; Black	-	<a href="#">Chapter 3</a> <a href="#">Page 173</a>

Frame MD

**HO9020**

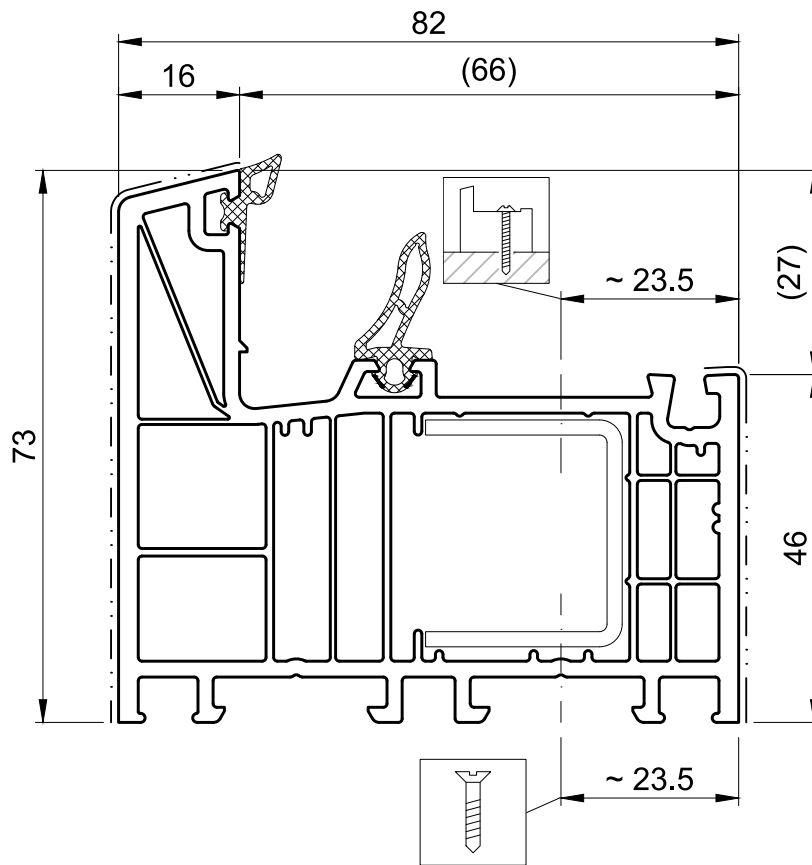

**Accessories** (not to scale)

Strengthening  
VS8020

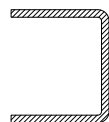

Strengthening  
VS8420

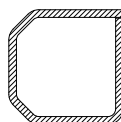

Glass rebate bridge  
GZ9010

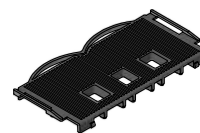

Frame MD

HO9021

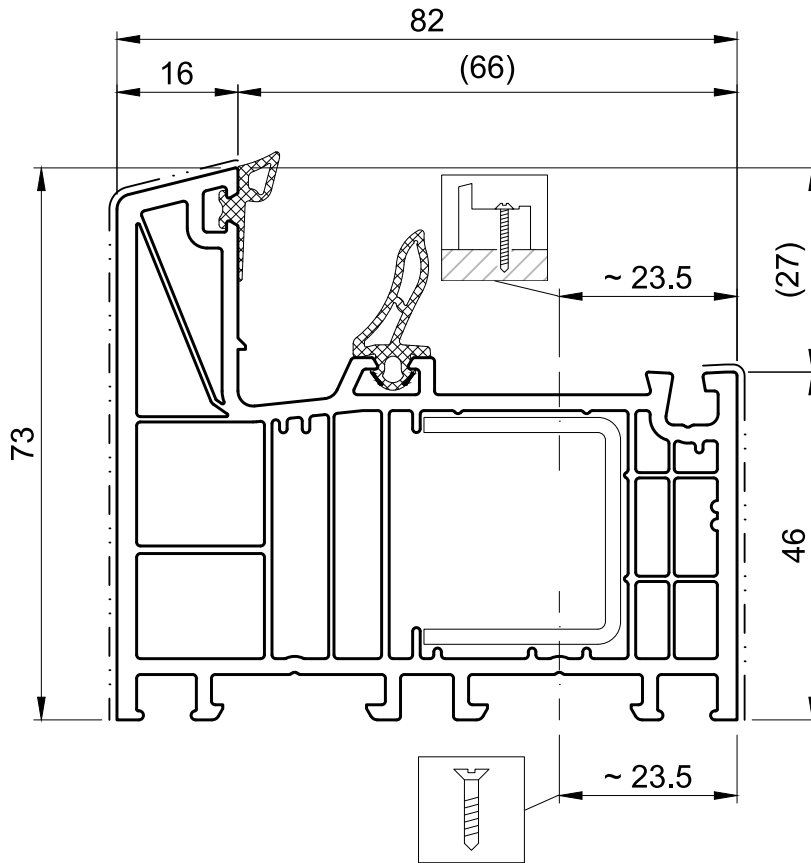
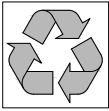

**Accessories (not to scale)**

Strengthening  
VS8020

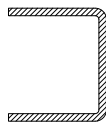

Strengthening  
VS8420

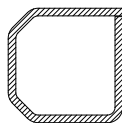

Glass rebate bridge  
GZ9010

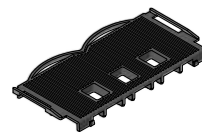

Frame AD

**HO8020**

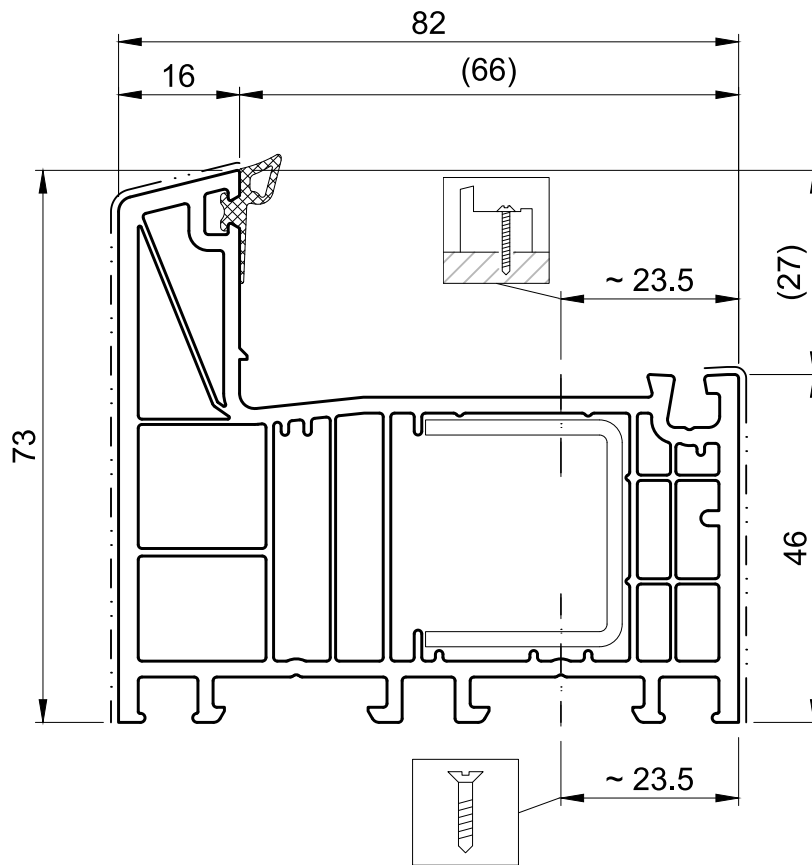

**Accessories** (not to scale)

Strengthening  
VS8020

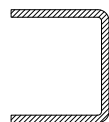

Strengthening  
VS8420

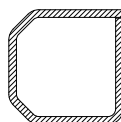

Glass rebate bridge  
GZ8010

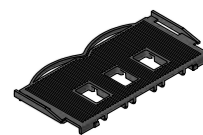

Frame AD

HO8021

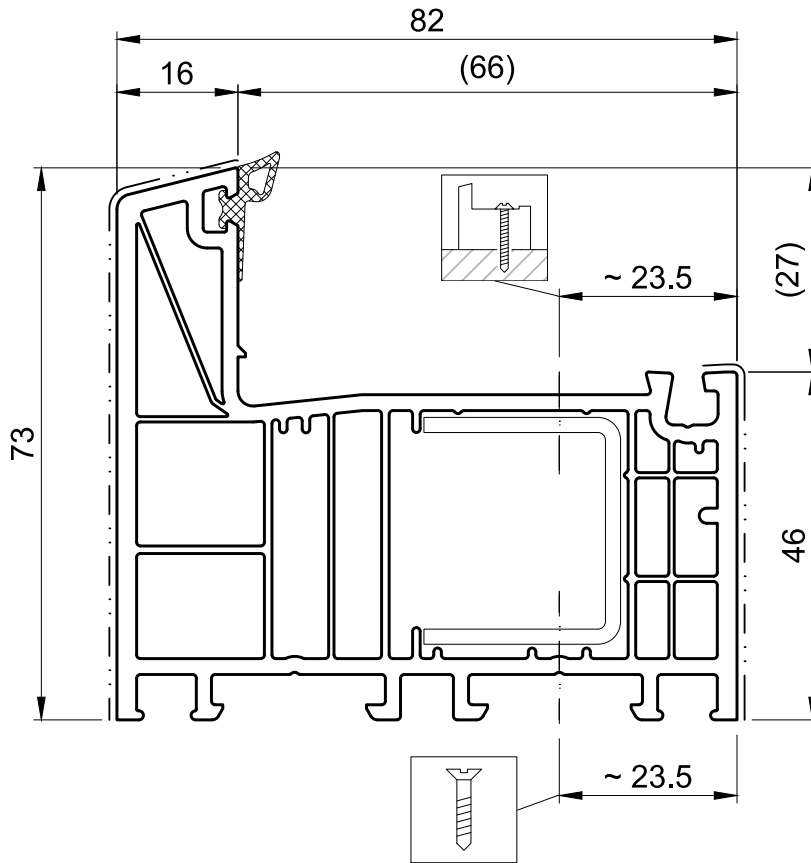
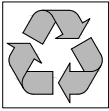

**Accessories (not to scale)**

Strengthening  
VS8020

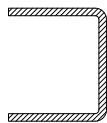

Strengthening  
VS8420

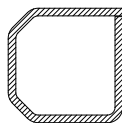

Glass rebate bridge  
GZ8010



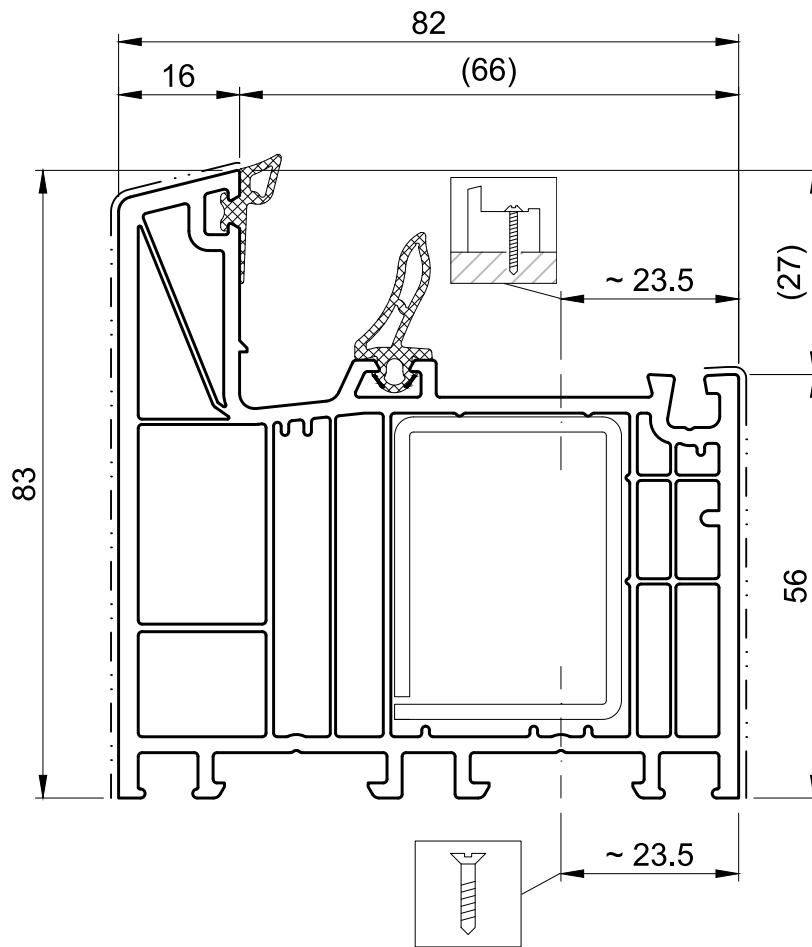

**Accessories** (not to scale)

Strengthening  
VS8230

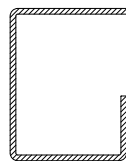

Strengthening  
405040

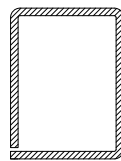

Glass rebate bridge  
GZ9010

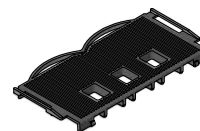

Frame MD

HP9220

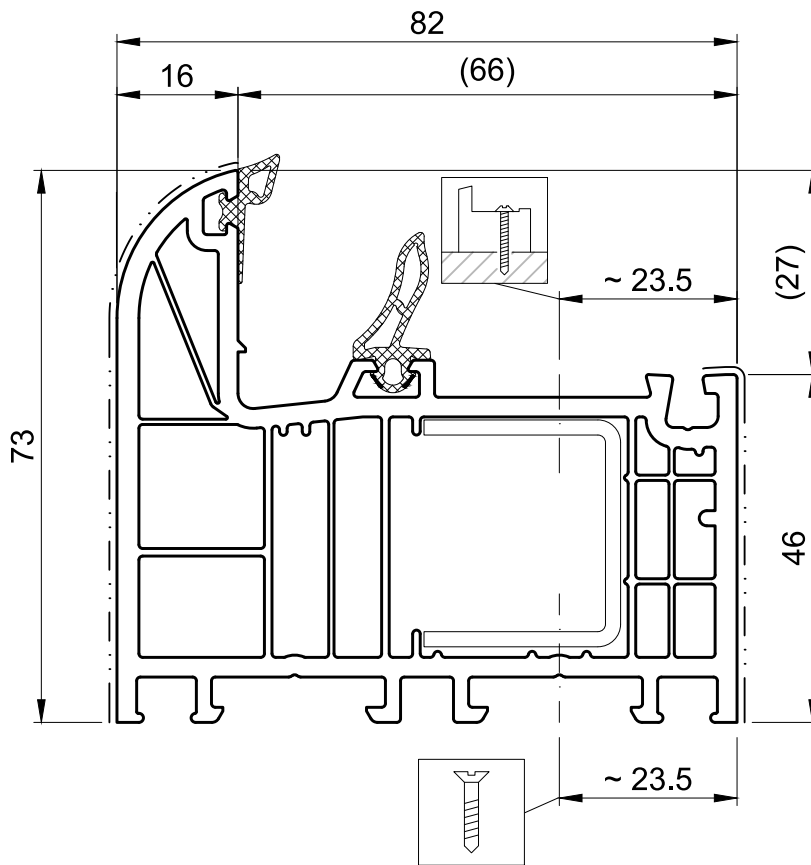

**Accessories** (not to scale)

Strengthening  
VS8020

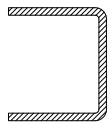

Strengthening  
VS8420

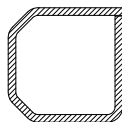

Glass rebate bridge  
GZ9010

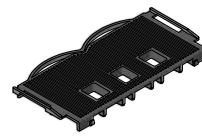

Frame AD

**HO8030**

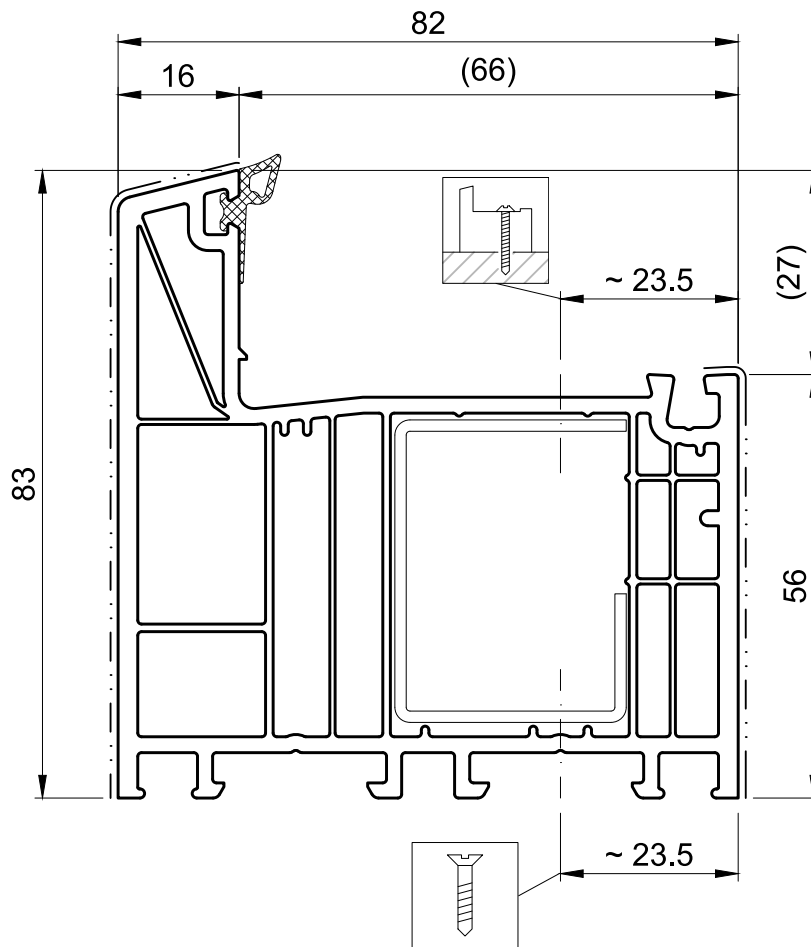

**Accessories** (not to scale)

Strengthening  
VS8230

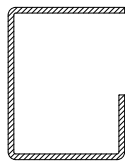

Strengthening  
405040

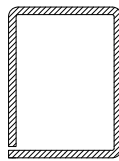

Glass rebate bridge  
GZ8010

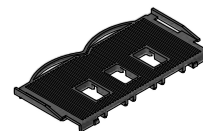

Frame MD

HO9050

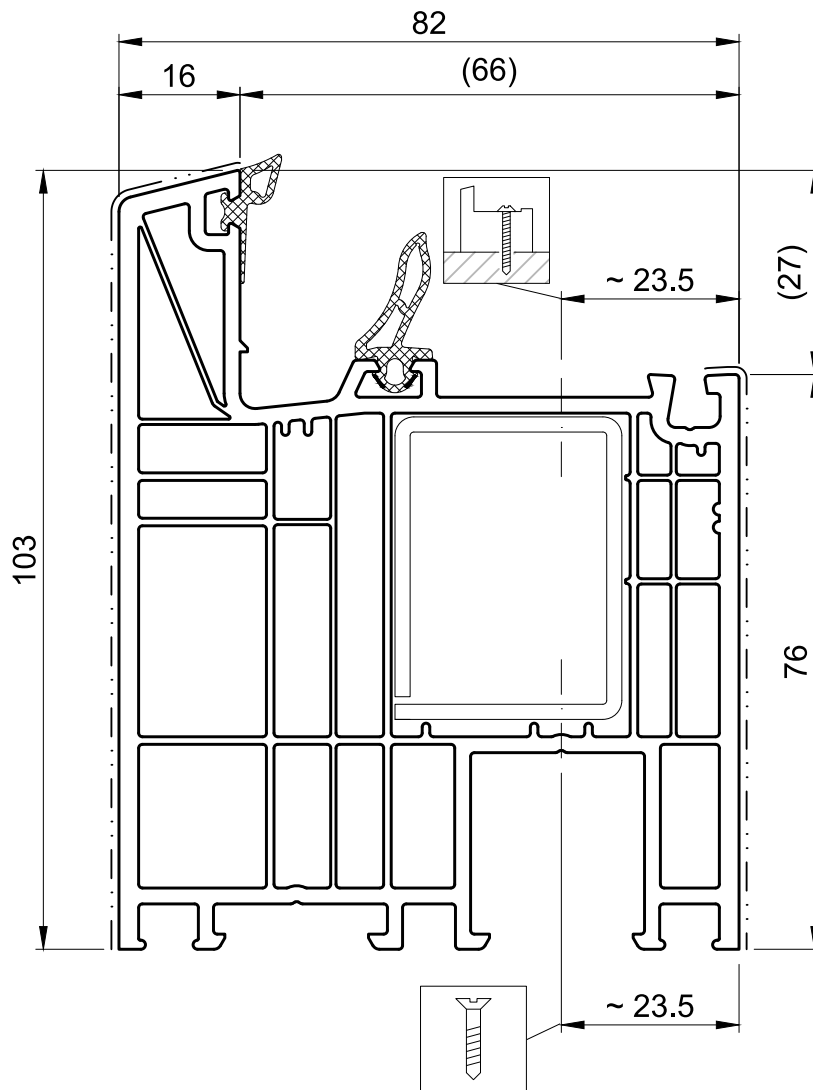

**Accessories** (not to scale)

Strengthening  
VS8230

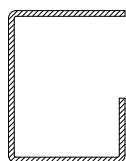

Strengthening  
405040

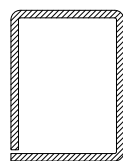

Glass rebate bridge  
GZ9010

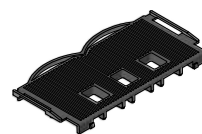

Old building frame MD

HO9110

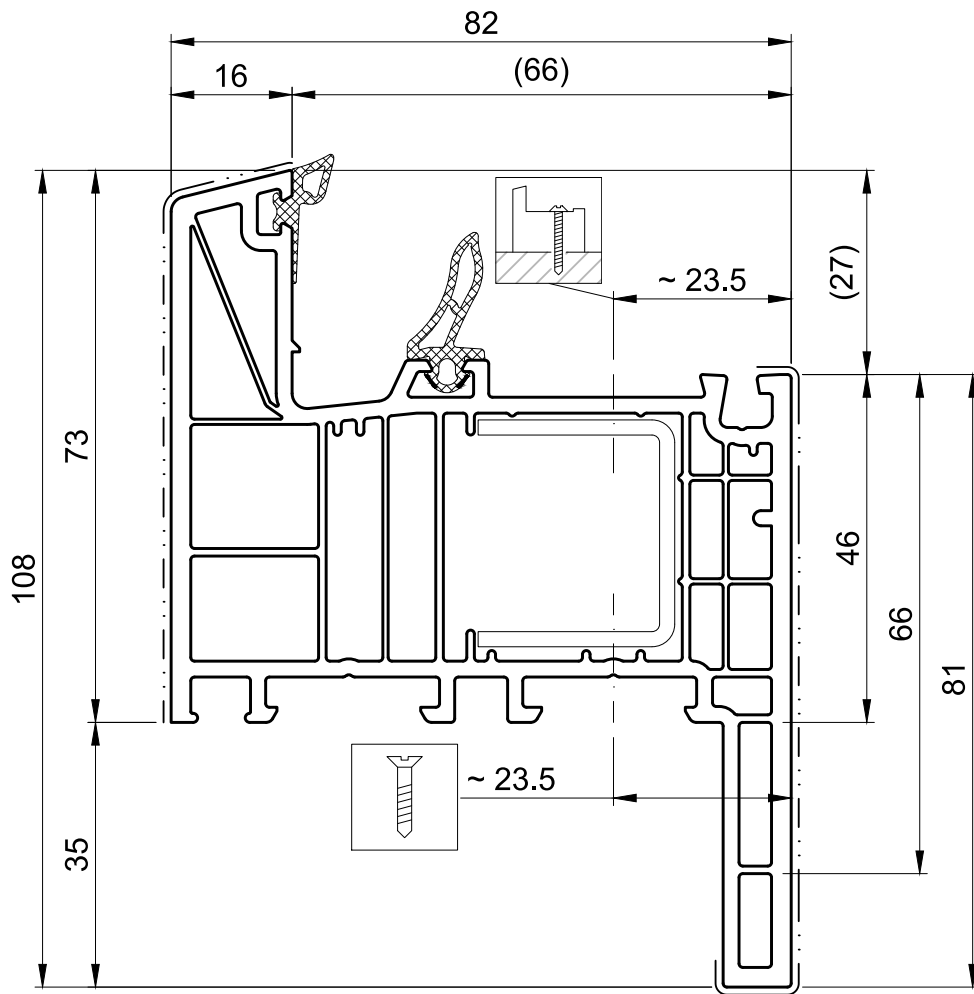

**Accessories (not to scale)**

Strengthening  
VS8020

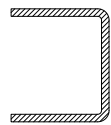

Strengthening  
VS8420

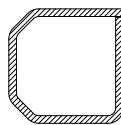

Glass rebate bridge  
GZ9010

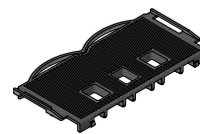

Old building frame MD

HO9120

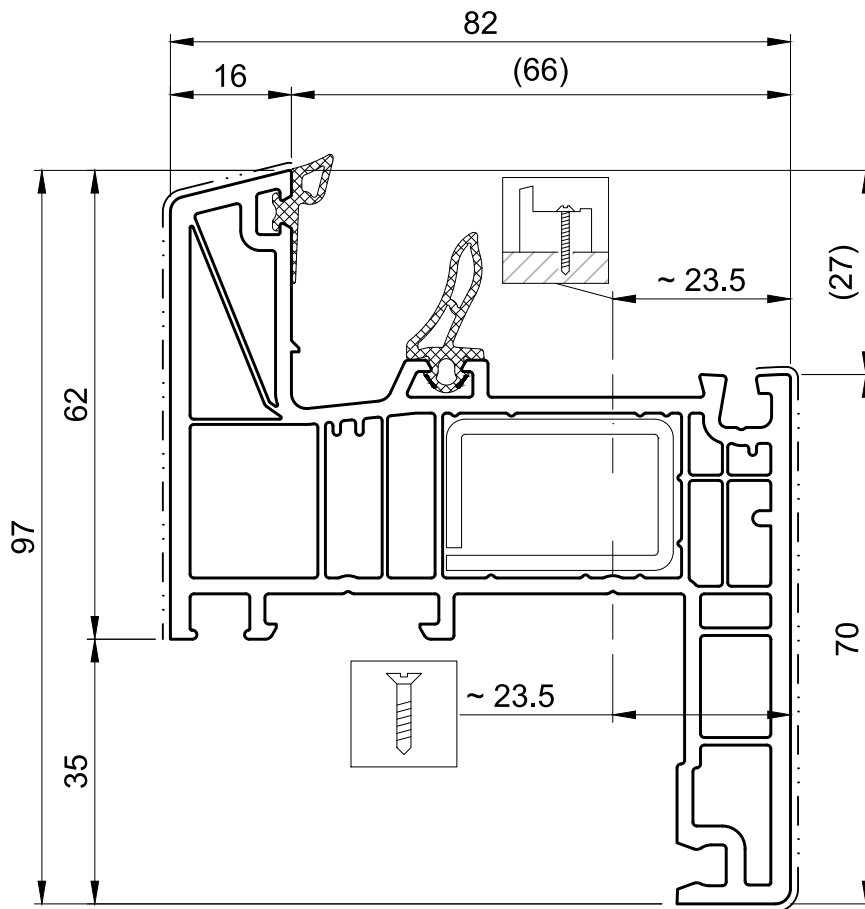

**Accessories (not to scale)**

Strengthening  
105011

Glass rebate bridge  
GZ9010

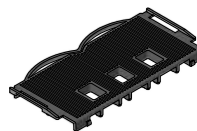

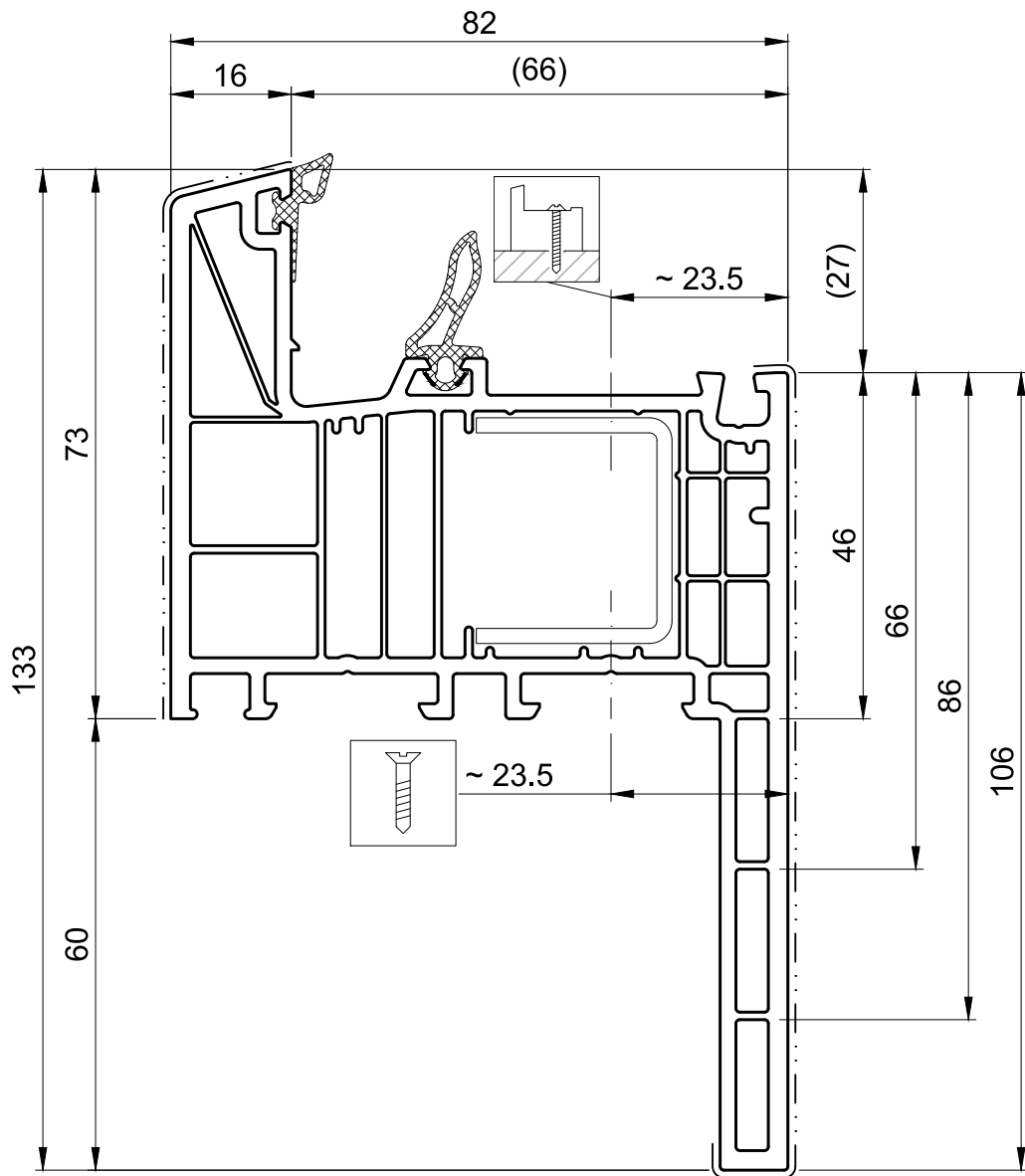

**Accessories (not to scale)**

Strengthening  
VS8020

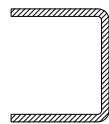

Strengthening  
VS8420

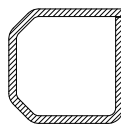

Glass rebate bridge  
GZ9010

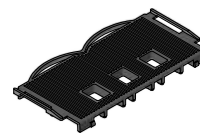

Sash  
HO8510

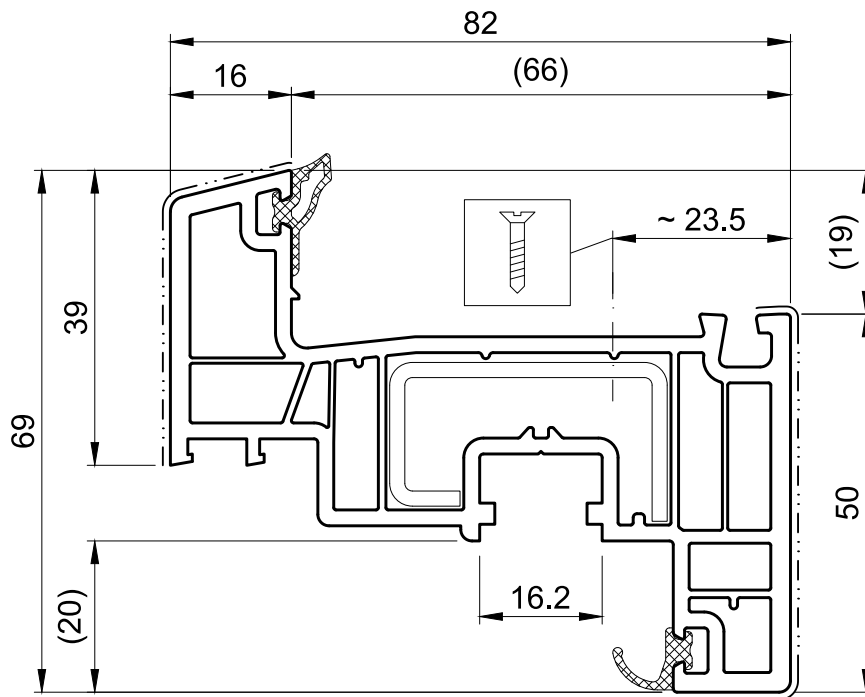

**Accessories** (not to scale)

Strengthening  
VS8510

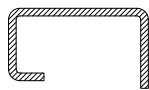

Rebate reinforcement  
MT8500

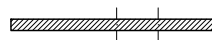

Glass rebate bridge  
GZ8010



Sash  
HO8520

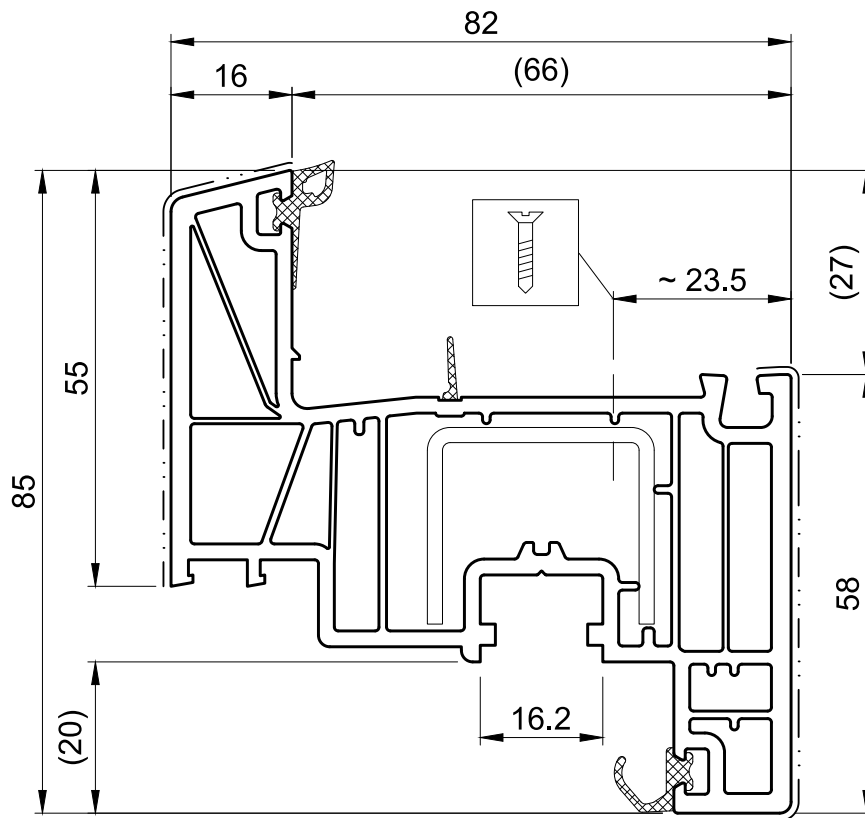

**Accessories** (not to scale)

Strengthening  
VS8020

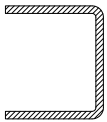

Strengthening  
VS8050

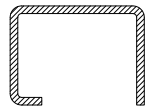

Strengthening  
VS8055

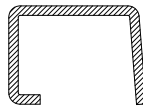

Strengthening  
VS8520

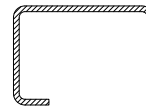

Strengthening  
VS8620

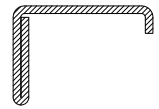

Strengthening  
VS9029

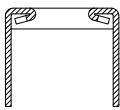

Rebate reinforcement  
MT8500



Glass rebate bridge  
GZ8010

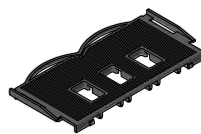

Sash  
HO8521

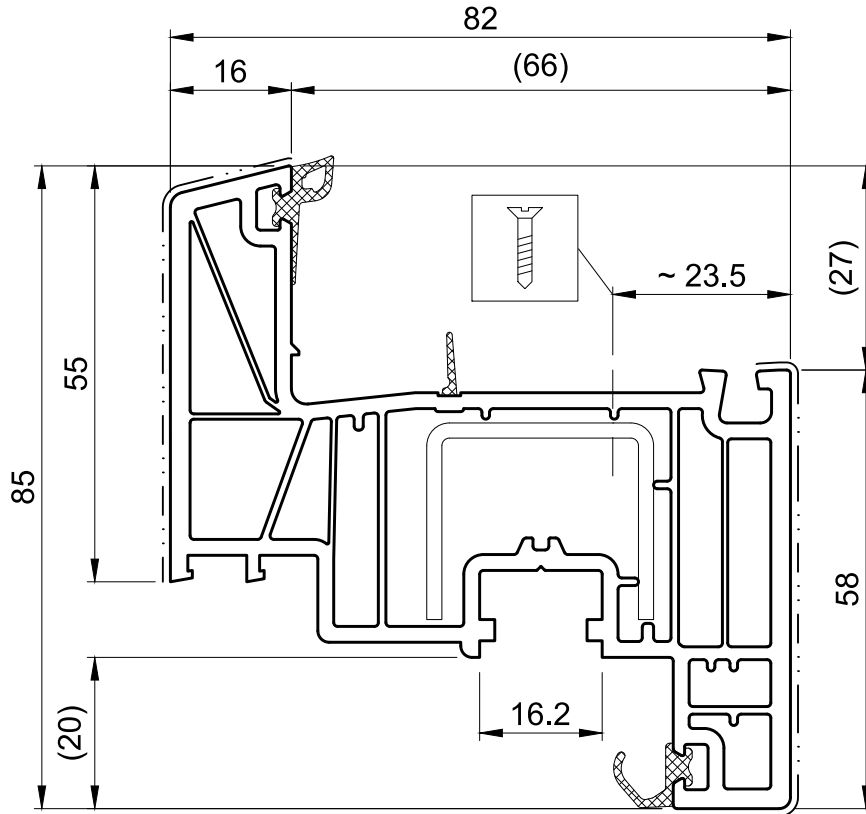
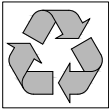

**Accessories (not to scale)**

Strengthening  
VS8020

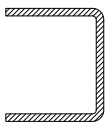

Strengthening  
VS8050

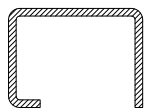

Strengthening  
VS8055

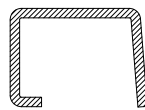

Strengthening  
VS8520

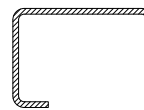

Strengthening  
VS8620

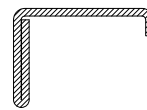

Strengthening  
VS9029

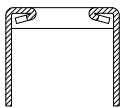

Rebate reinforcement  
MT8500

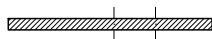

Glass rebate bridge  
GZ8010

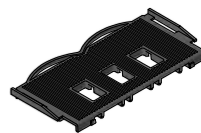

Sash

HP8920

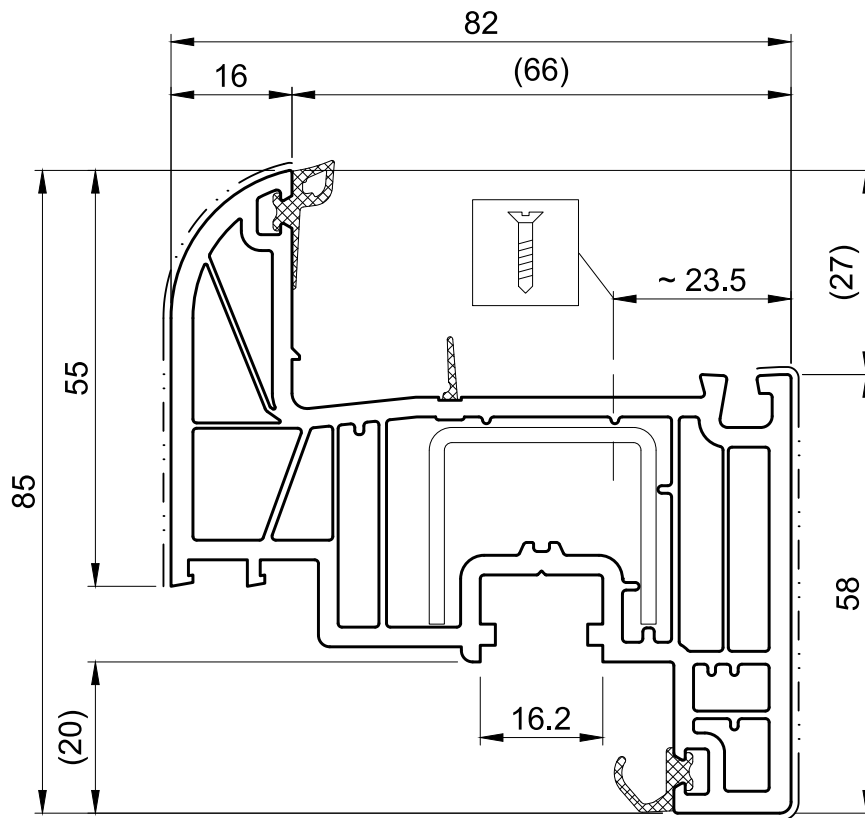

**Accessories** (not to scale)

Strengthening  
VS8020

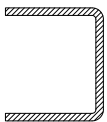

Strengthening  
VS8050

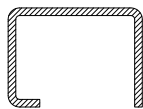

Strengthening  
VS8055

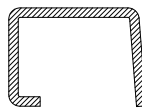

Strengthening  
VS8520

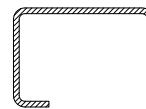

Strengthening  
VS8620

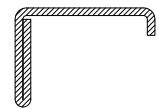

Strengthening  
VS9029

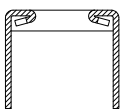

Rebate reinforcement  
MT8500



Glass rebate bridge  
GZ8010



Sash  
HO8530

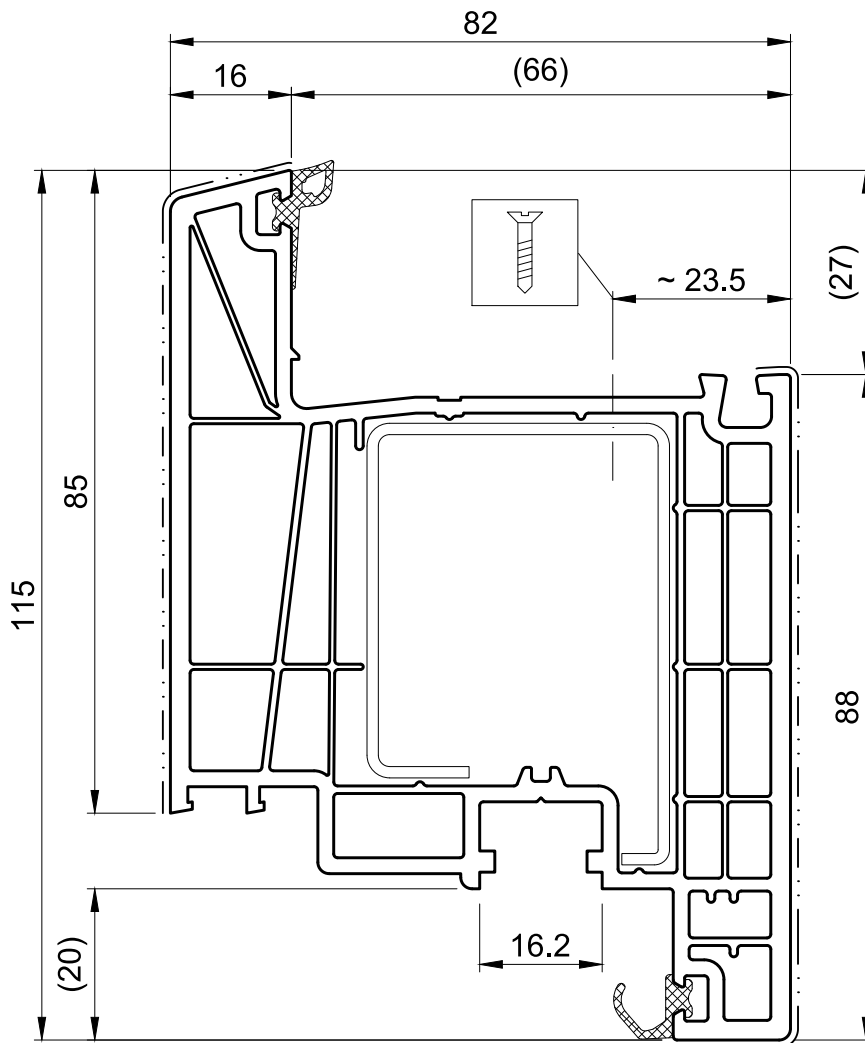

**Accessories (not to scale)**

Strengthening  
VS8030

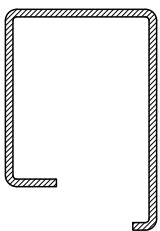

Strengthening  
VS8450

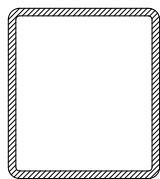

Strengthening  
MT8530

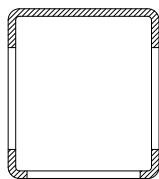

Rebate reinforcement  
MT8500

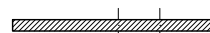

Glass rebate bridge  
GZ8010

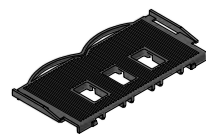

Clamping lever

207910

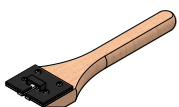

Weldable corner connector

MT8540

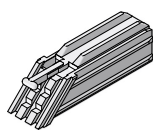

Sash  
HO8540

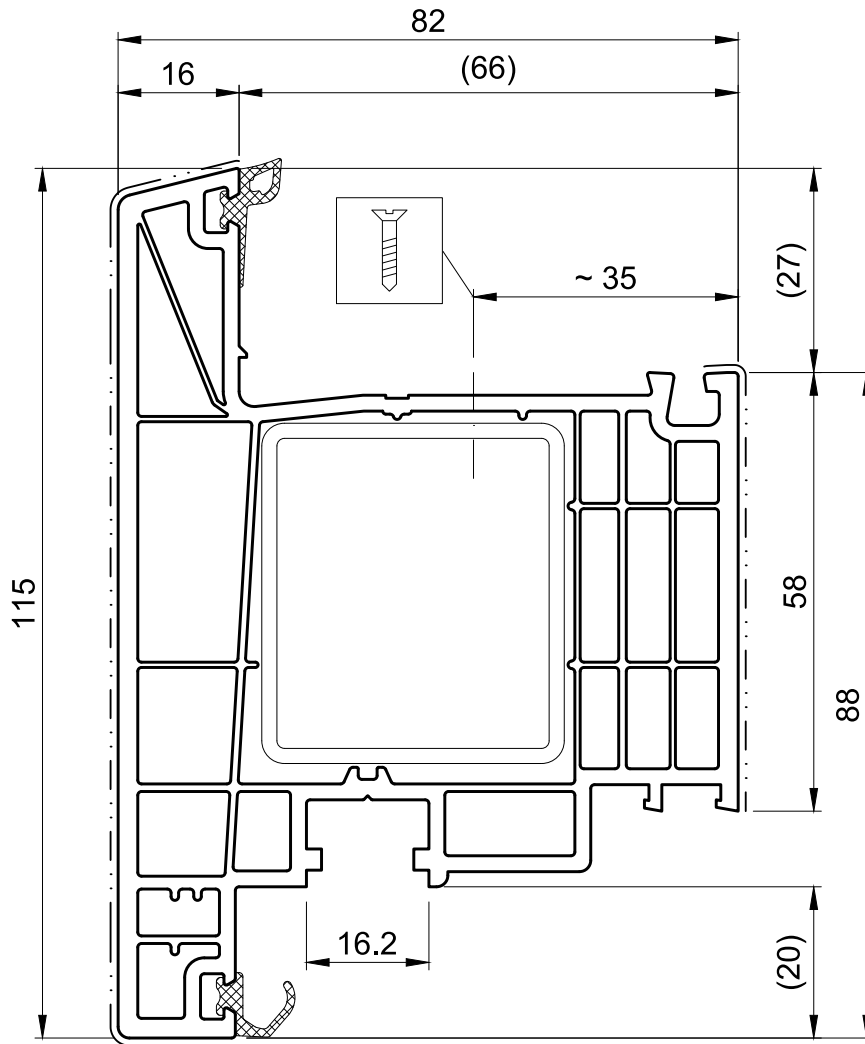

**Accessories (not to scale)**

Strengthening

VS8450

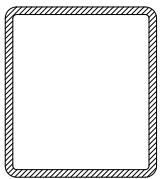

Clamping lever  
207910

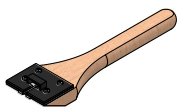

Strengthening

MT8530

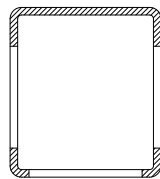

Rebate reinforcement Glass rebate bridge

MT8500



GZ8010

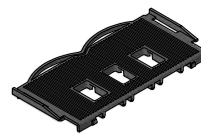

Weldable corner connector

MT8540

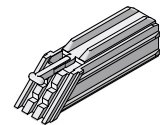

Sash  
HP8930

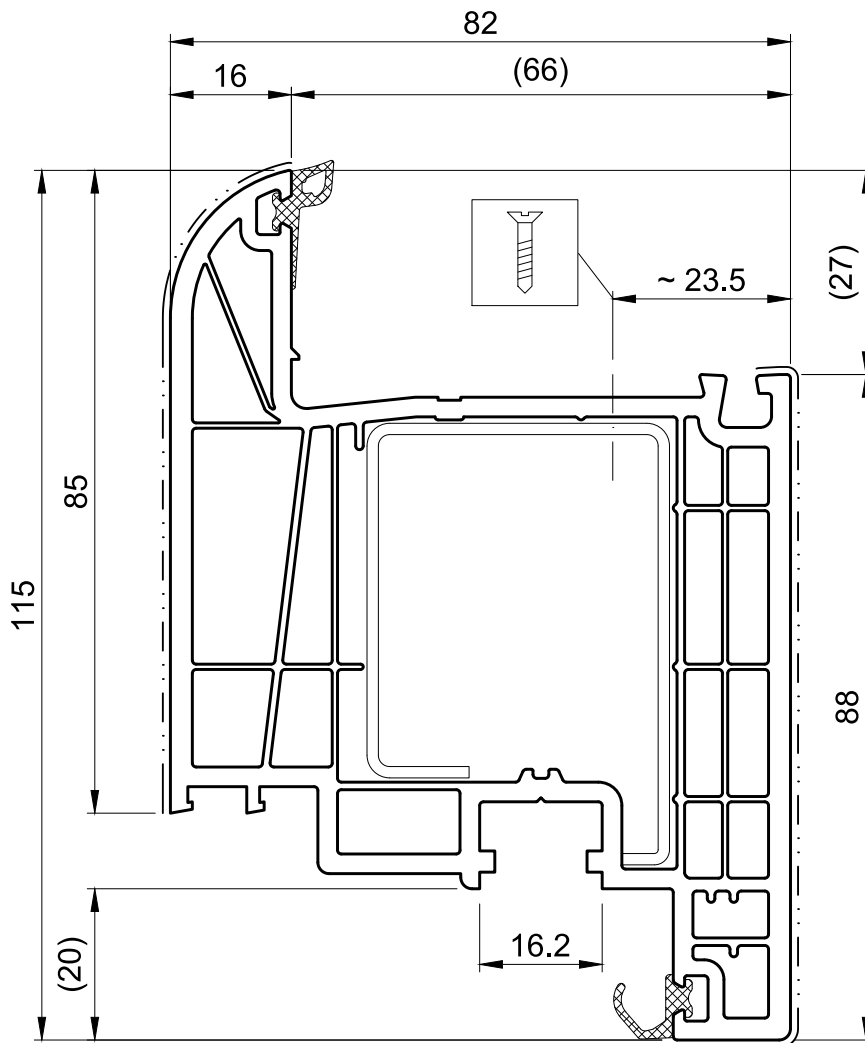

**Accessories (not to scale)**

Strengthening  
VS8030

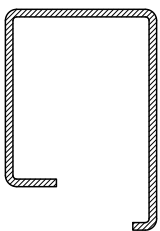

Strengthening  
VS8450

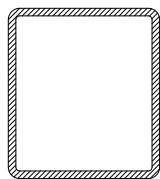

Strengthening  
MT8530

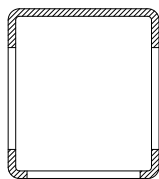

Rebate reinforcement  
MT8500

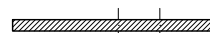

Glass rebate bridge  
GZ8010

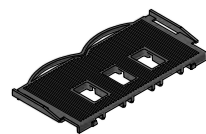

Clamping lever

207910

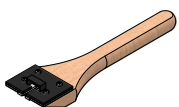

Weldable corner connector

MT8540

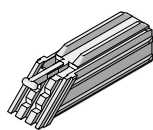

Sash

HP8550

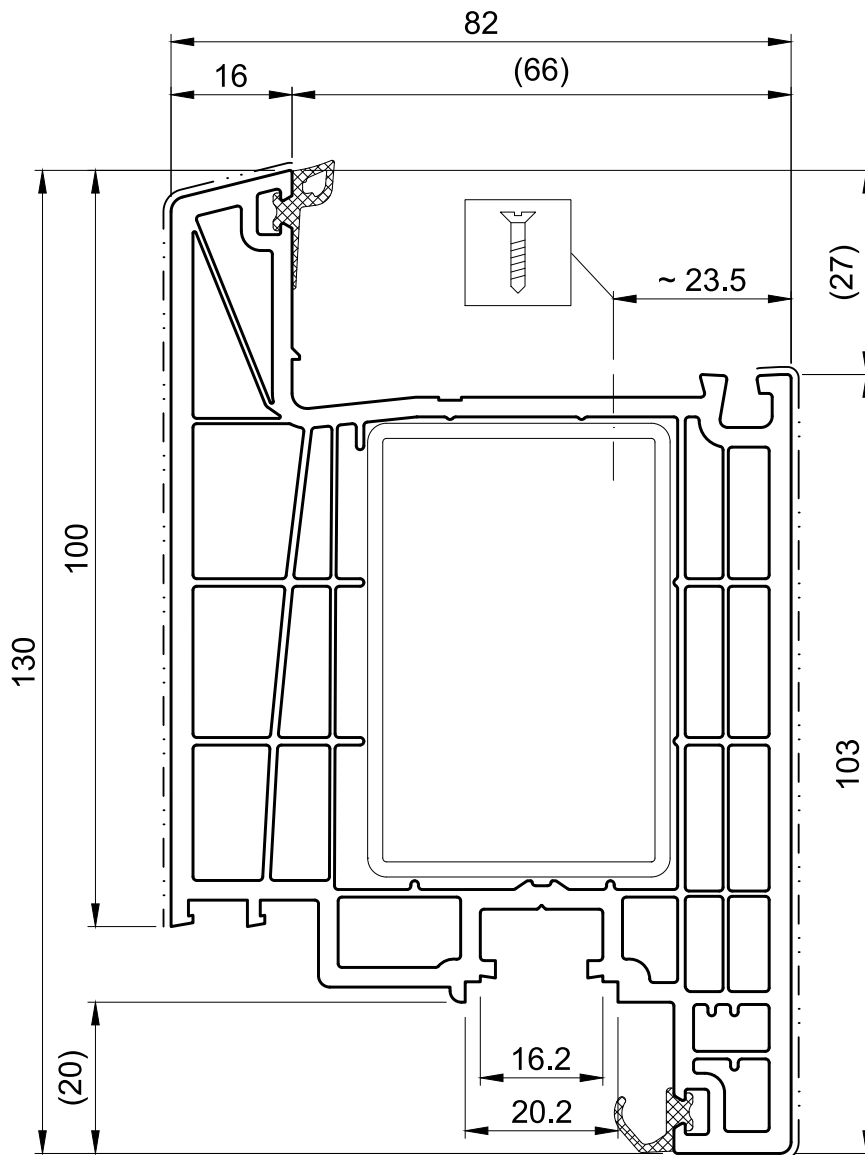

**Accessories** (not to scale)

Strengthening

AR4630

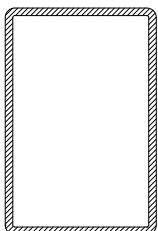

Clamping lever  
207910

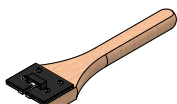

Strengthening

MT8551

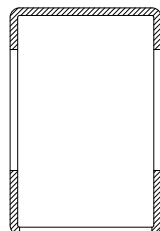

Rebate reinforcement

MT8500

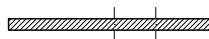

Glass rebate bridge

GZ8010



Weldable corner connector

MT4631

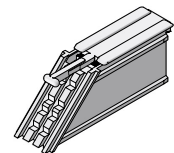

Sash  
HP8560

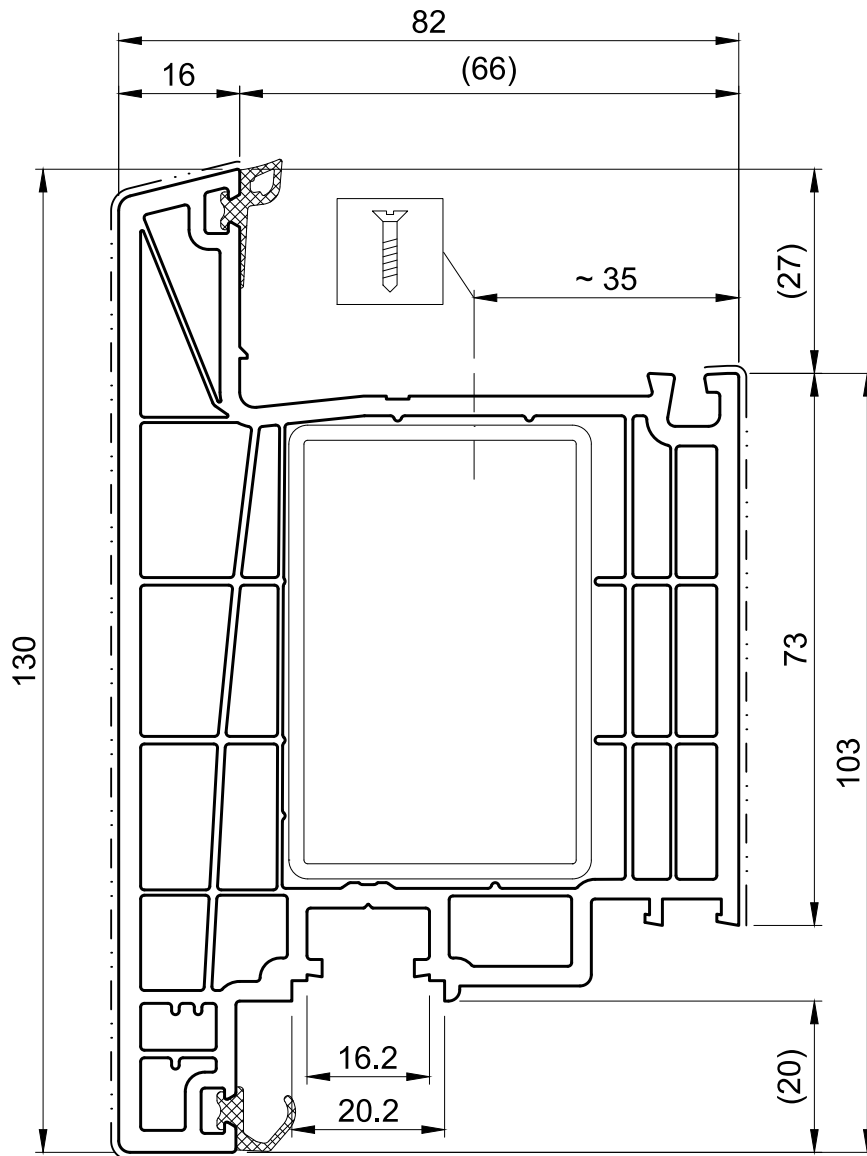

**Accessories (not to scale)**

Strengthening

AR4630

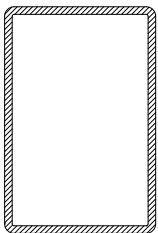

Strengthening

MT8551

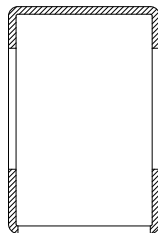

Rebate reinforcement Glass rebate bridge

MT8500

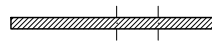

GZ8010

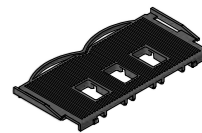

Weldable corner connector

MT4631

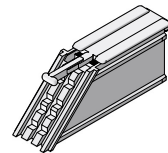

Clamping lever  
207910

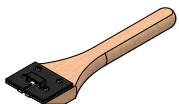

Sash  
HO8580

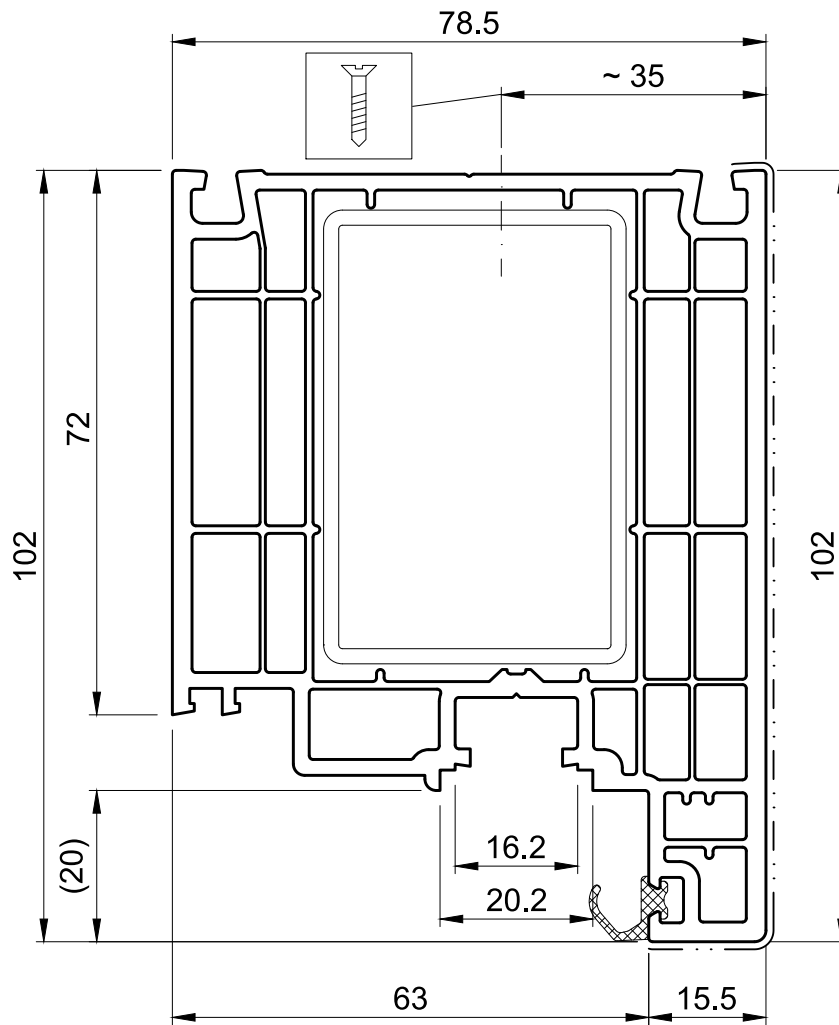

**Accessories (not to scale)**

Strengthening

Strengthening

Weldable corner connector

Clamping lever

AR4630

MT8551

MT4631

207910

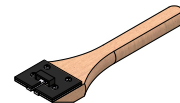
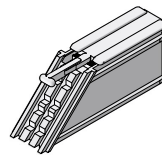
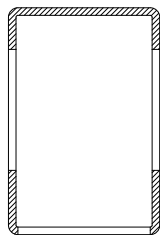
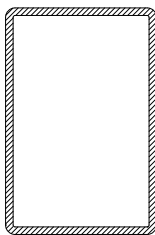

Fixed mullion MD

HO9310

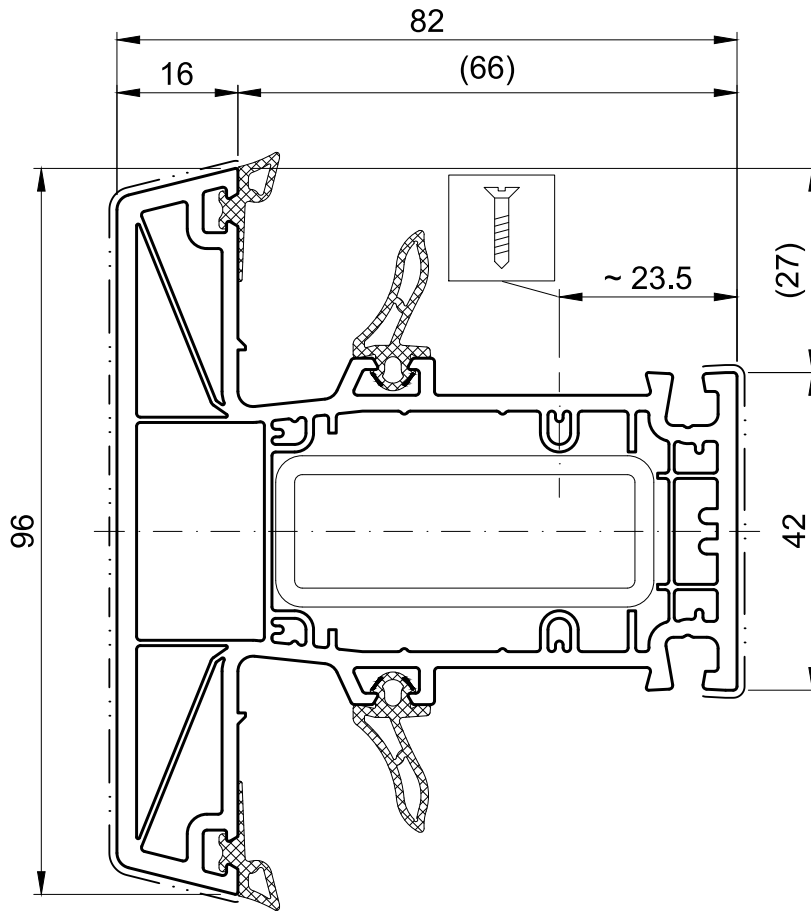

**Accessories (not to scale)**

Strengthening

475021



Strengthening

VS8310

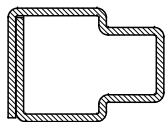

Glass rebate bridge

GZ9010

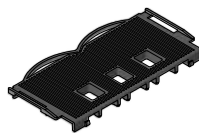

Fixed-mullion connector set

ZS9320

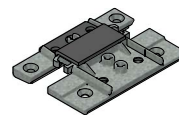

Fixed-mullion connector set

ZS9321

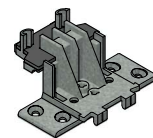

Fixed-mullion connector set

ZS9420



Sealing block

MT8220

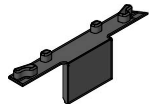

Sealing fitting

MT9010



Sealing pad

MT9310



Sealing block

MT9320

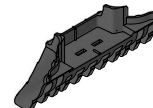

Drilling jig

MT9900

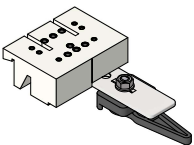

Drilling jig

MT9901

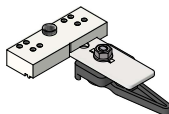

Cutting jig

MT9910

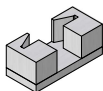

Fixed mullion MD

HO9320

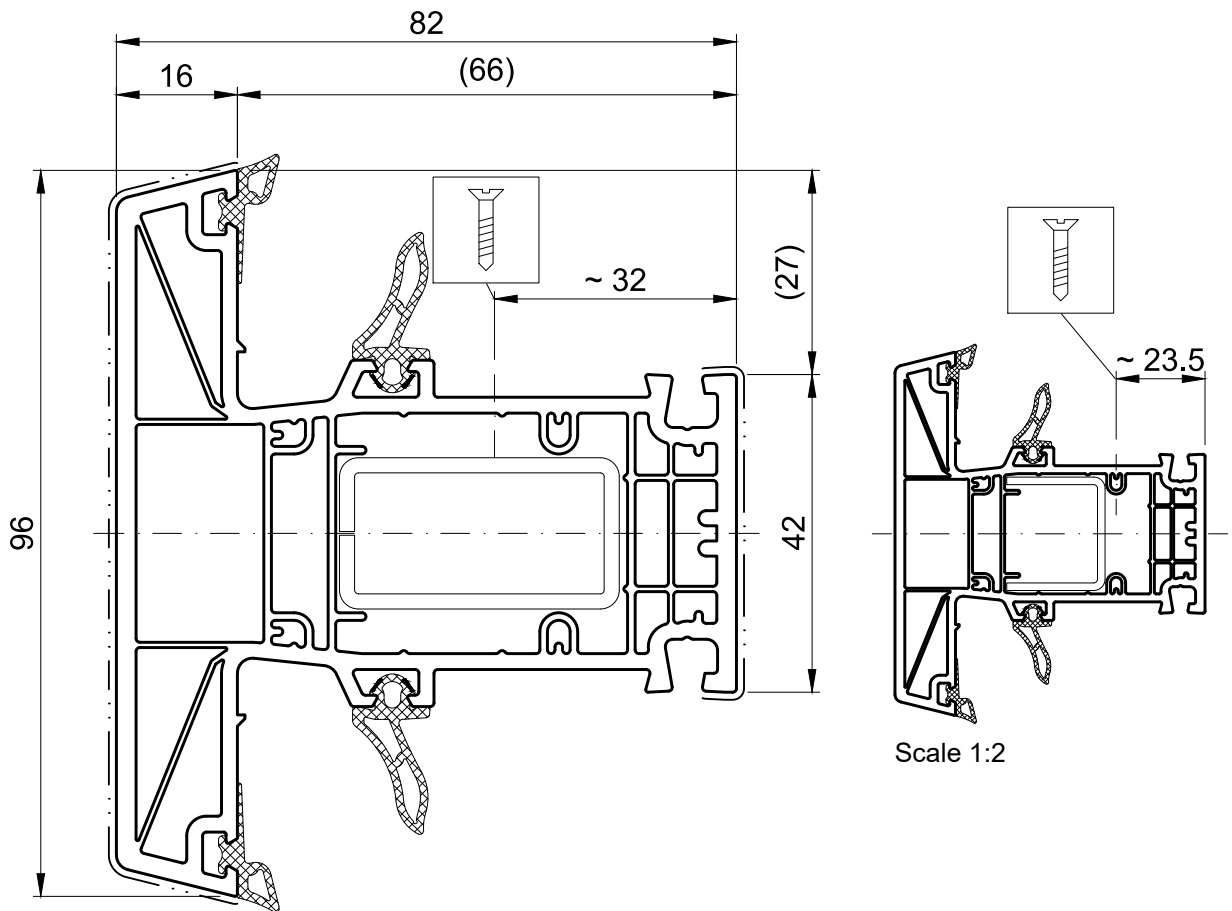

**Accessories** (not to scale)

Strengthening

VS8020

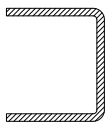

Fixed-mullion connector set

ZS9420



Drilling jig

MT9901

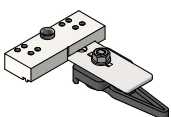

Strengthening

VS8320



Sealing block

MT8220

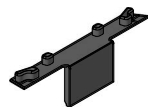

Cutting jig

MT9910

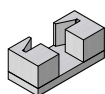

Glass rebate bridge

GZ9010

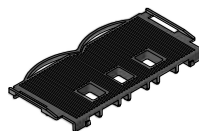

Sealing fitting

MT9010



Fixed-mullion connector set

ZS9320

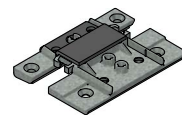

Sealing block

MT9320

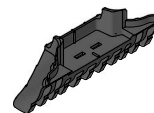

Fixed-mullion connector set

ZS9321

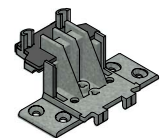

Drilling jig

MT9900

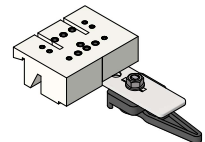

Fixed mullion MD

HO9330

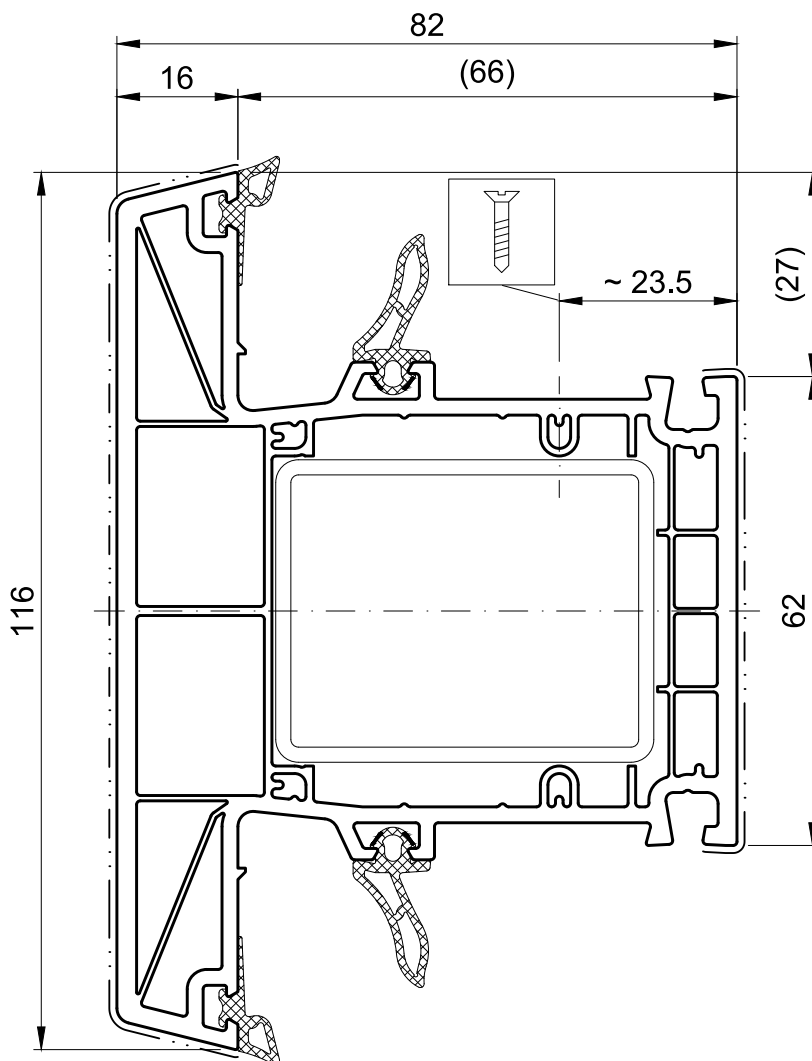

**Accessories (not to scale)**

Strengthening

405065



Sealing block  
MT8240

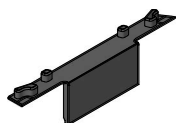

Glass rebate bridge

GZ9010

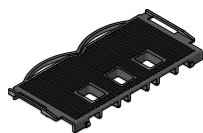

Sealing pad  
MT9330

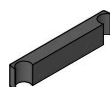

Fixed-mullion connector set

ZS8340

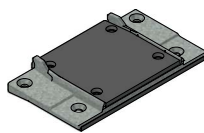

Sealing block  
MT9340

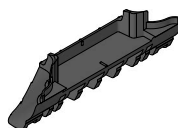

Fixed-mullion connector set

ZS8343

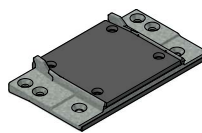

Drilling jig  
MT9901

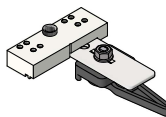

Fixed-mullion connector set

ZS9341

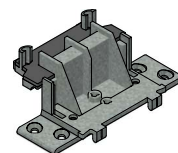

Drilling jig  
MT9902

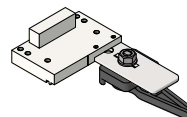

Fixed mullion MD

**HO9340**

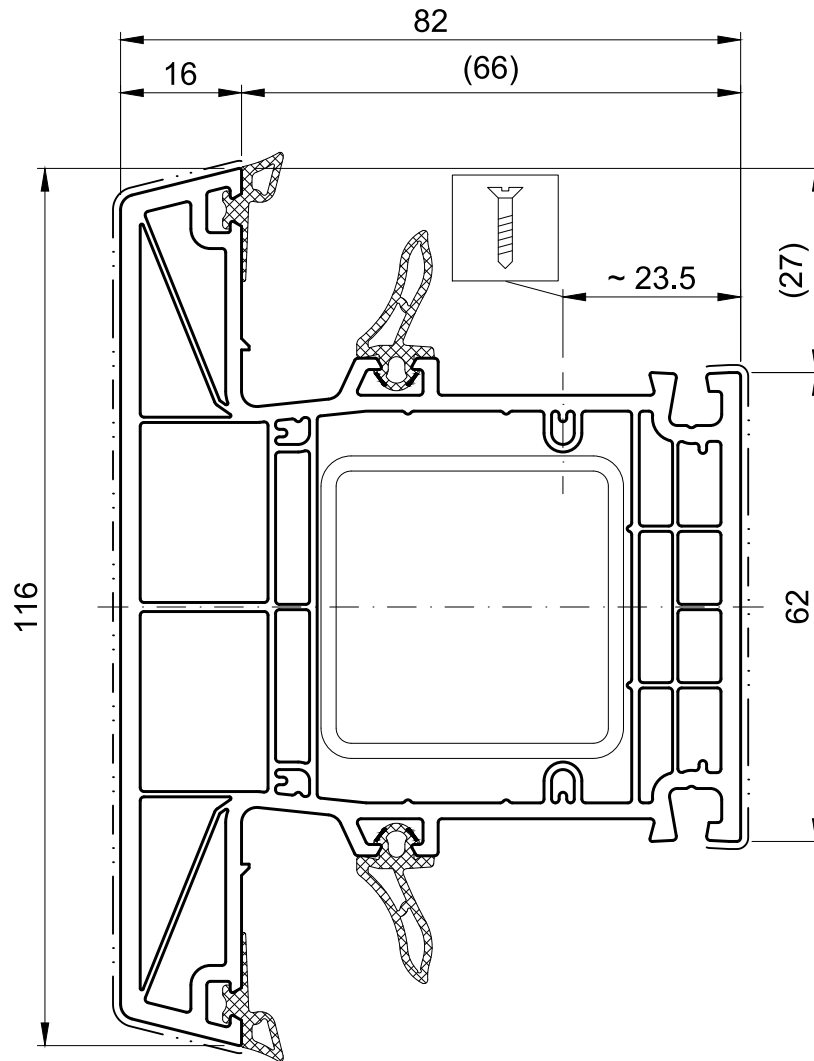

**Accessories (not to scale)**

Strengthening

415040

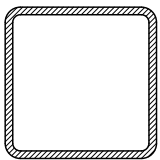

Sealing block  
MT8240

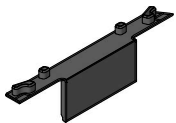

Glass rebate bridge

GZ9010

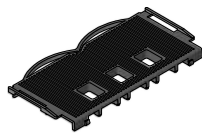

Sealing block  
MT9340

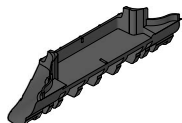

Fixed-mullion connector set

ZS8340

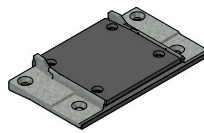

Drilling jig  
MT9901

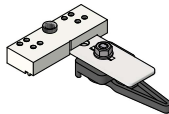

Fixed-mullion connector set

ZS8343

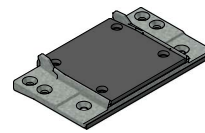

Drilling jig  
MT9902

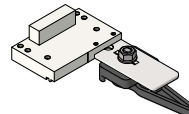

Fixed-mullion connector set

ZS9341

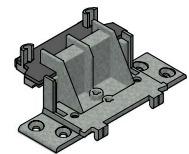

Fixed mullion MD

HP9420

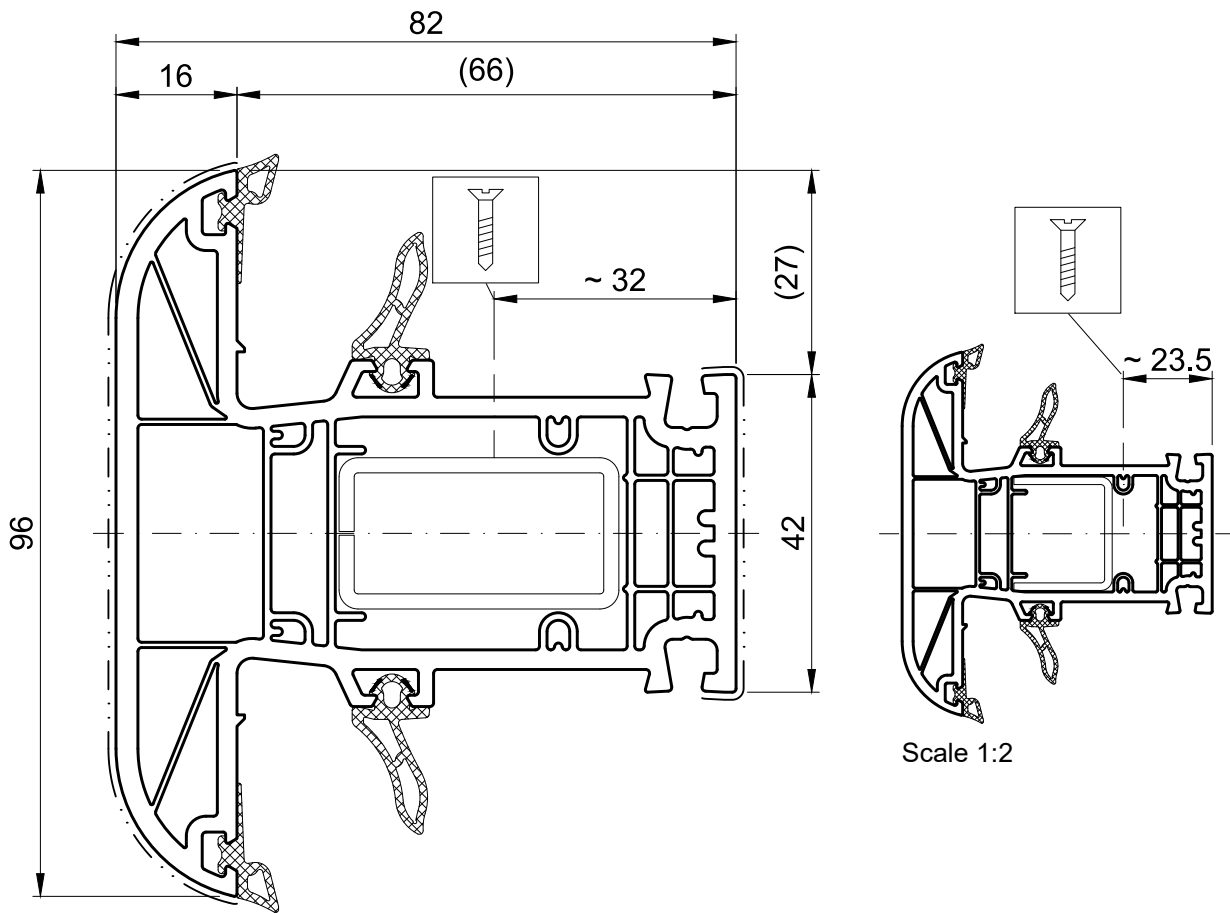

**Accessories (not to scale)**

Strengthening

VS8020

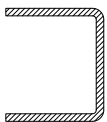

Strengthening

VS8320



Glass rebate bridge

GZ9010

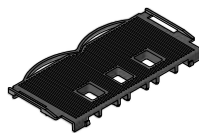

Fixed-mullion connector set

ZS9320

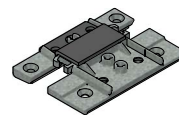

Fixed-mullion connector set

ZS9321

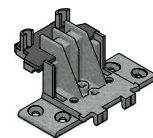

Fixed-mullion connector set

ZS9420



Sealing block

MT8230

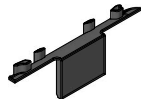

Sealing fitting

MT9010



Sealing block

MT9320

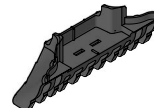

Drilling jig

MT9900

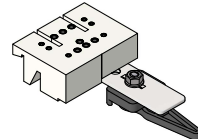

Drilling jig

MT9901

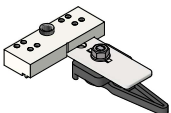

Cutting jig

MT9910

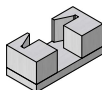

Fixed mullion AD

**HO8310**

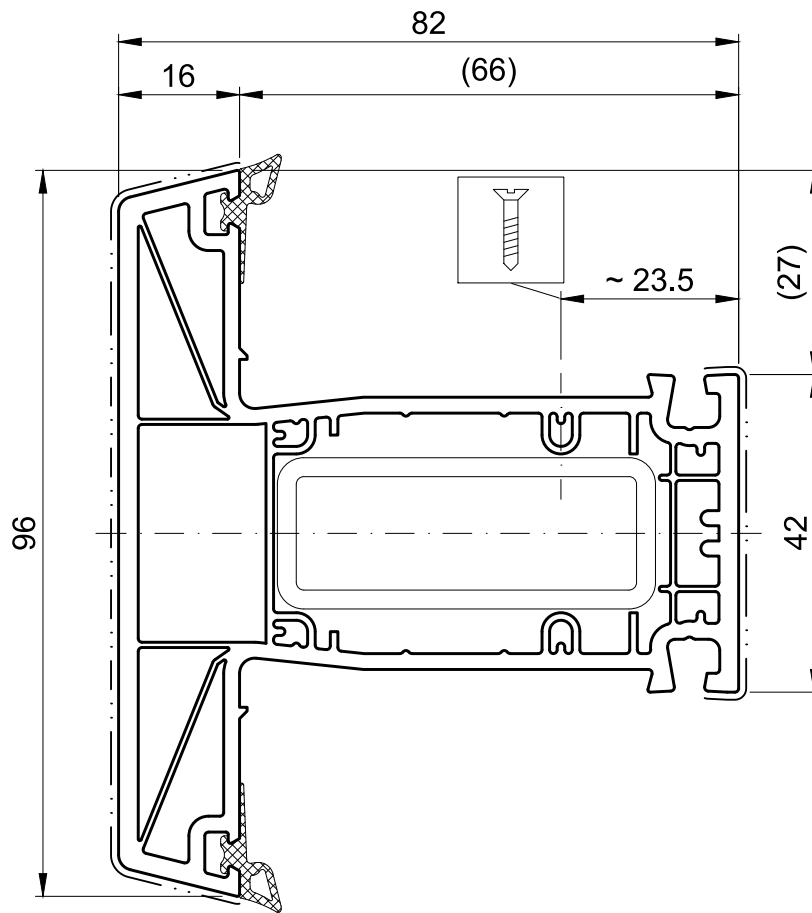

**Accessories** (not to scale)

Strengthening

475021



Strengthening

VS8310

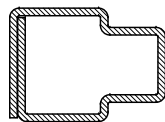

Glass rebate bridge

GZ8010

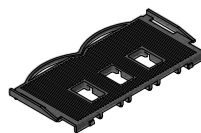

Fixed-mullion connector set

ZS8320



Fixed-mullion connector set

ZS8323



Fixed-mullion connector set

ZS8420



Sealing block

MT8220

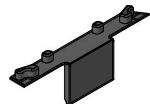

Drilling jig

MT9900

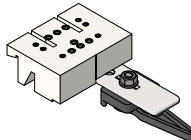

Fixed mullion AD

HO8320

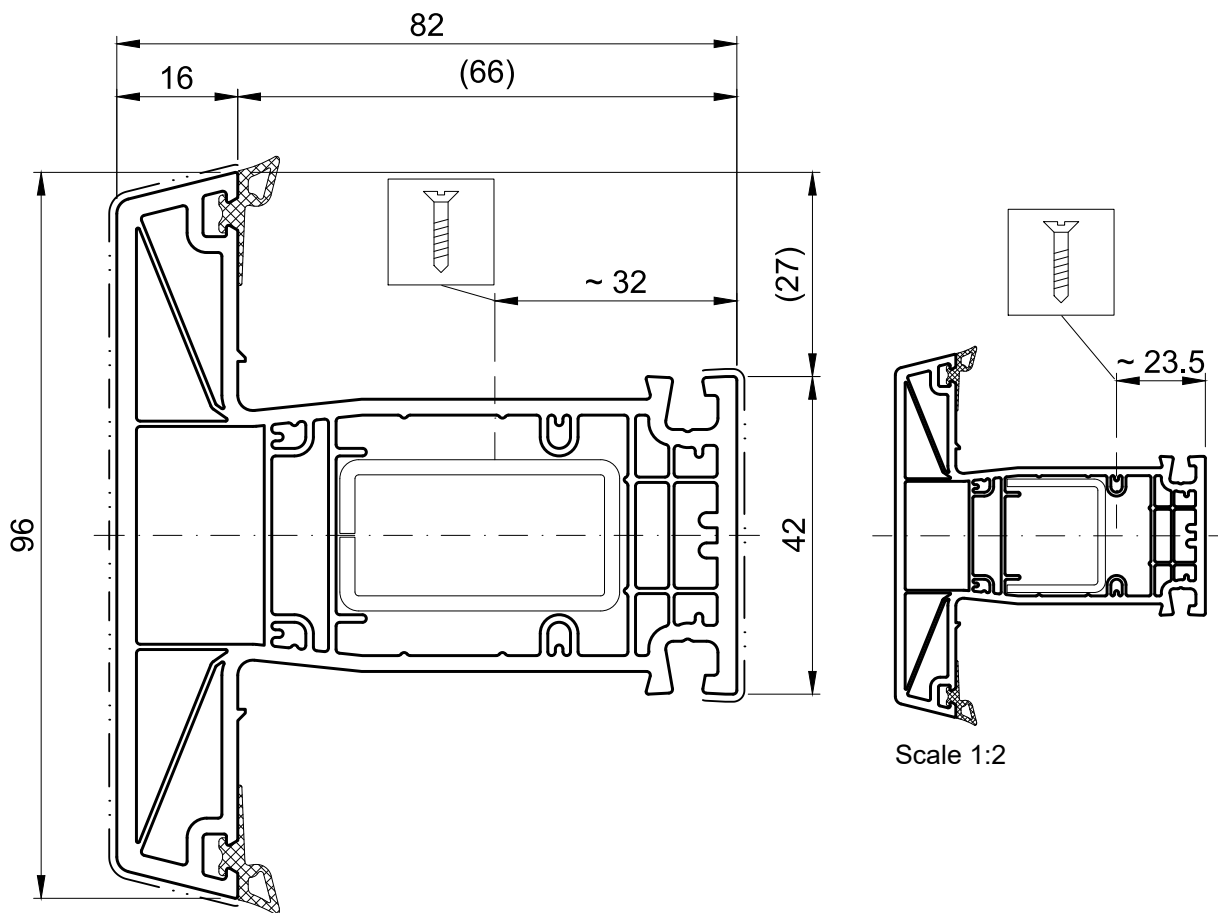

**Accessories (not to scale)**

Strengthening

VS8020

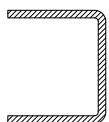

Strengthening

VS8320



Glass rebate bridge

GZ8010

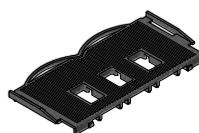

Fixed-mullion connector set

ZS8320



Fixed-mullion connector set

ZS8323



Fixed-mullion connector set

ZS8420

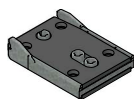

Sealing block

MT8220

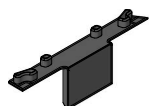

Drilling jig

MT9900

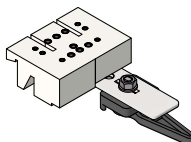

Glazing bar AD

**HO8300**

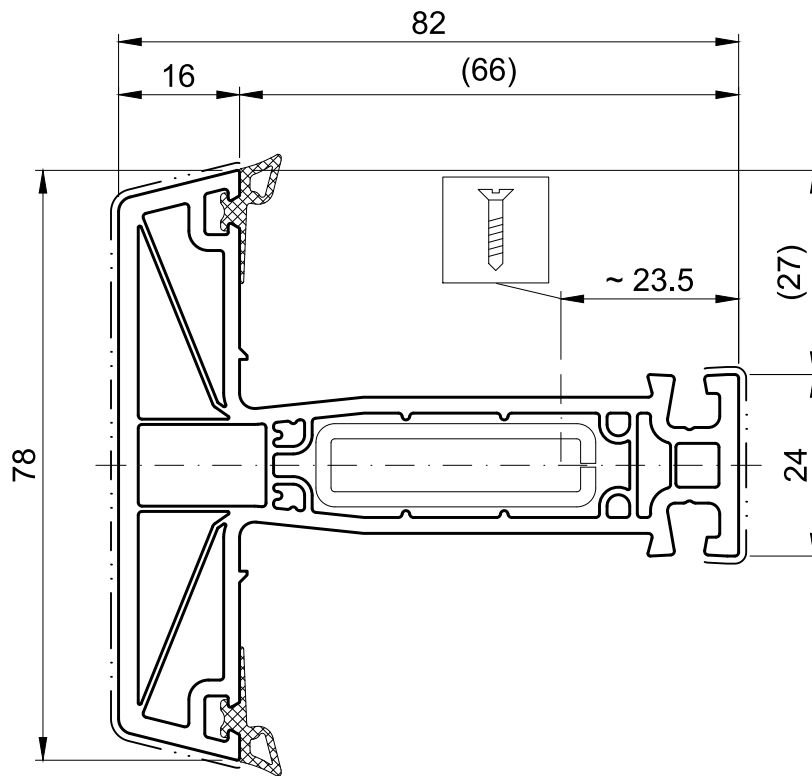

**Accessories (not to scale)**

Strengthening  
VS8300



Glass rebate bridge  
GZ8010

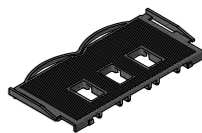

Mullion connector set  
ZS8300



Mullion connector set  
ZS8303



Sealing block  
MT8200

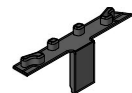

Drilling jig  
MT9920

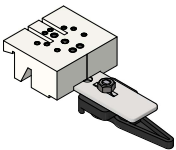

Faceplate, right-angled profile

HO9820

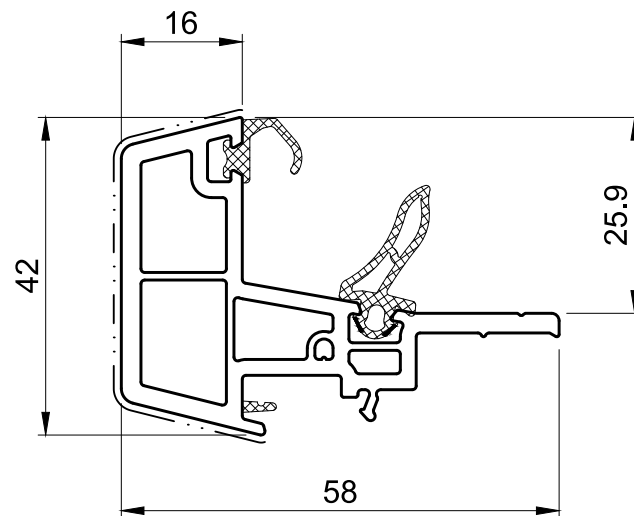

**Accessories** (not to scale)

Faceplate end cover cap set

ZS9820

Cover cap  
ES9860

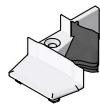

French window sash

**HO8570**

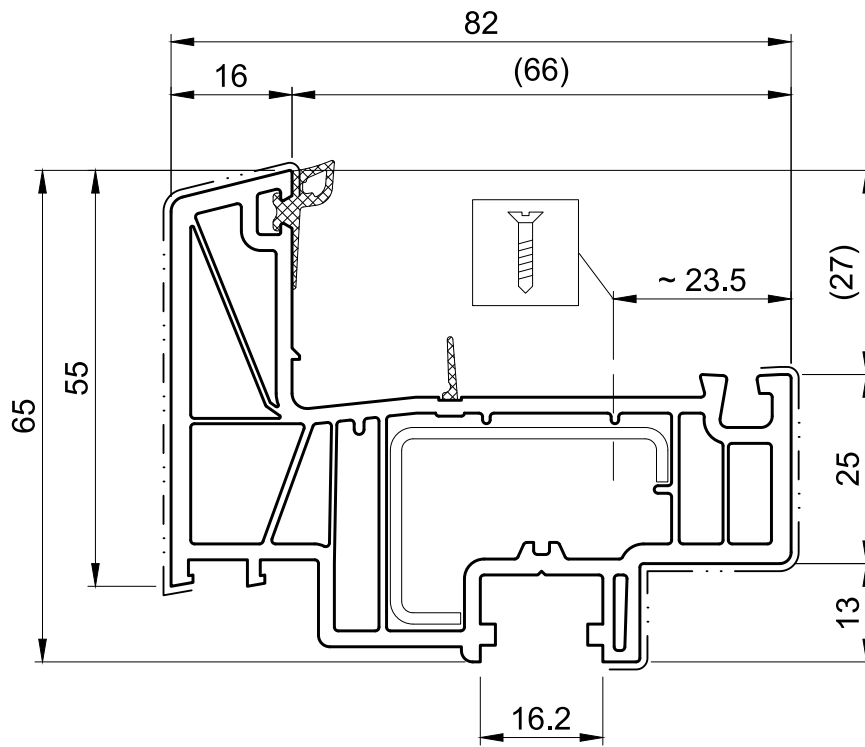

**Accessories** (not to scale)

Strengthening  
VS8520



Strengthening  
VS8620

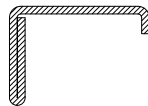

Rebate reinforcement  
MT8500

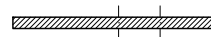

Glass rebate bridge  
GZ8010

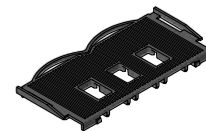

Right-angled profile MD

HO9810

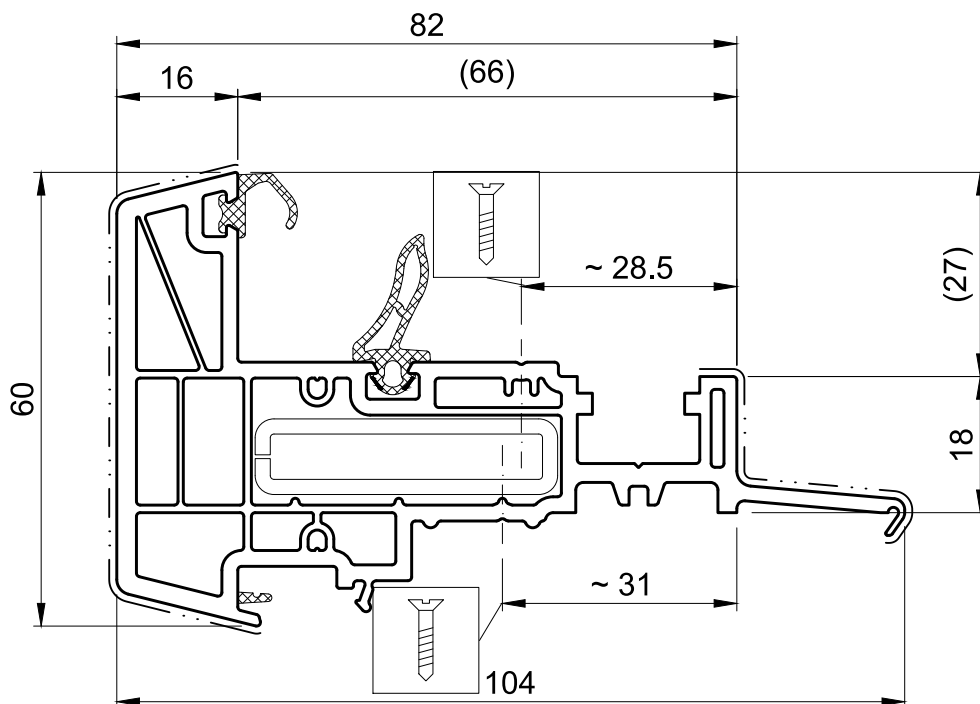

**Accessories** (not to scale)

Strengthening

VS9810

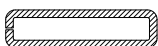

Faceplate end cover cap set

ZS9811

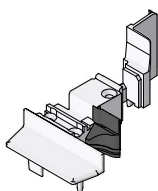

Floating-mullion end cover cap outside

ES9830



Floating-mullion end cover cap inside

ES9821

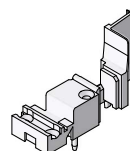

Sealing fitting

MT9800



Right-angled profile MD

**HO9800**

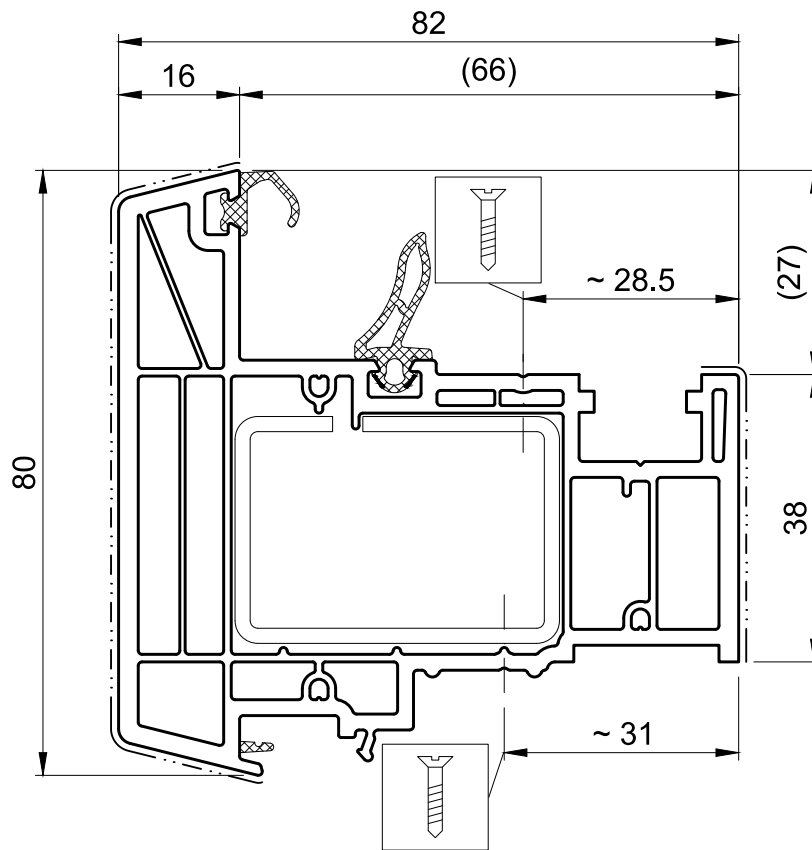

**Accessories (not to scale)**

Strengthening

VS8020

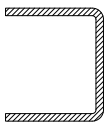

Strengthening

VS9800



Faceplate end cover cap set  
ZS9801

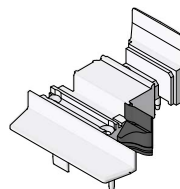

Floating-mullion end cover cap outside  
ES9810

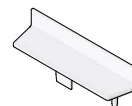

Floating-mullion end cover cap inside  
ES9801

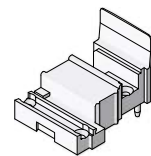

Sealing fitting

MT9800



Right-angled profile MD

HO9850

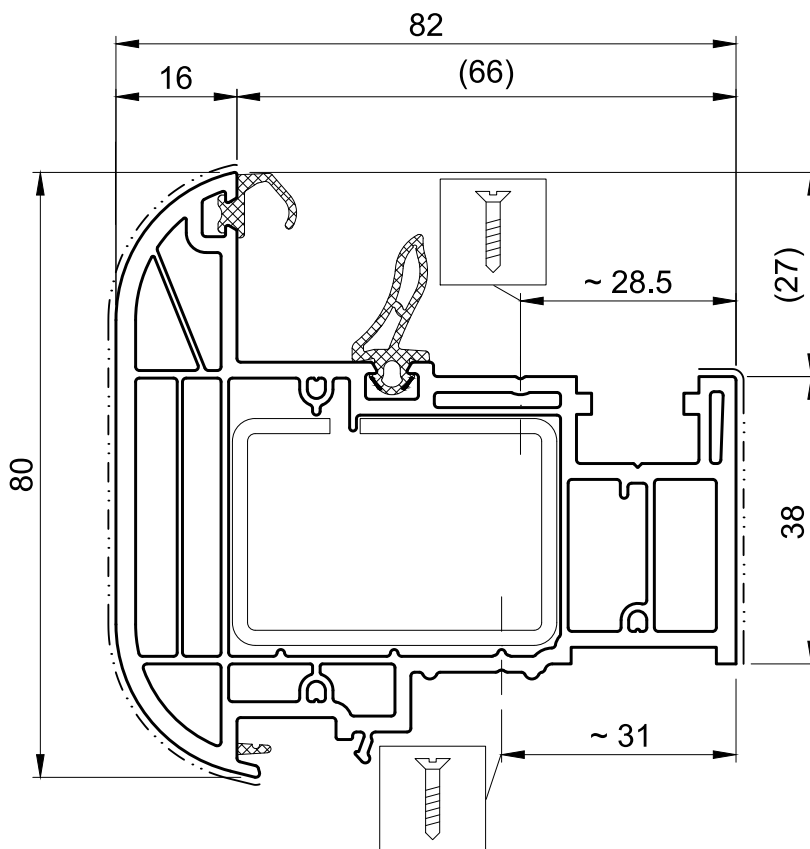

**Accessories** (not to scale)

Strengthening

VS8020

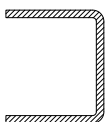

Strengthening

VS9800



Faceplate end cap set  
ZS9851

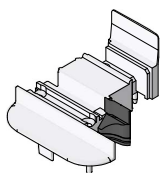

Floating-mullion end cover cap outside  
ES9850

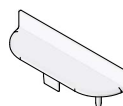

Floating-mullion end cover cap inside  
ES9801

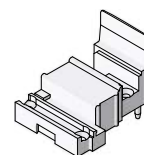

Sealing fitting

MT9800



Right-angled profile AD

**HO8800**

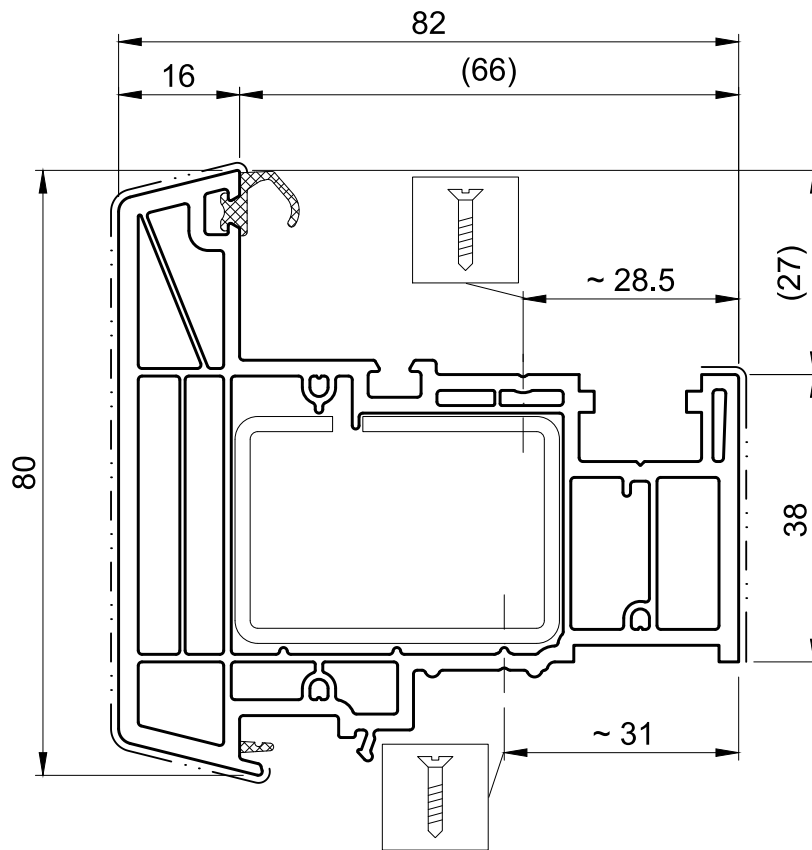

**Accessories** (not to scale)

Strengthening

VS8020

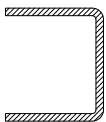

Strengthening

VS9800



Faceplate end cover cap set  
ZS8801

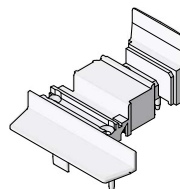

Floating-mullion end cover cap outside  
ES9810

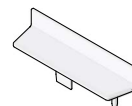

Floating-mullion end cover cap inside  
ES9801

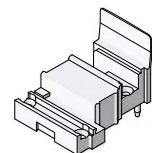

Beading  
NP8000



Glazing-beads

27 mm

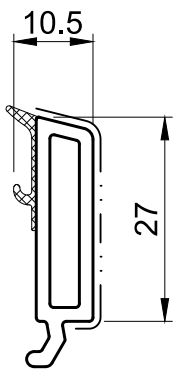

GP8520

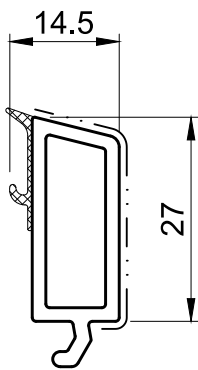

GP8480

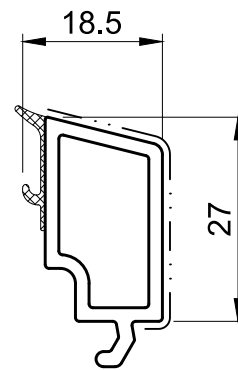

GP8440

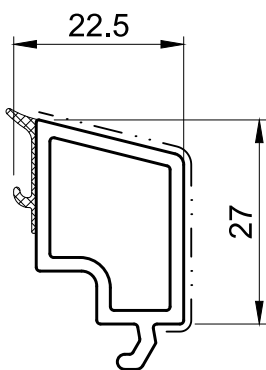

GP8400

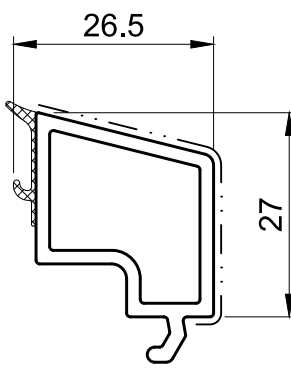

GP8360

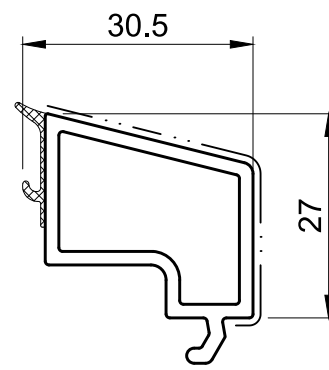

GP8320

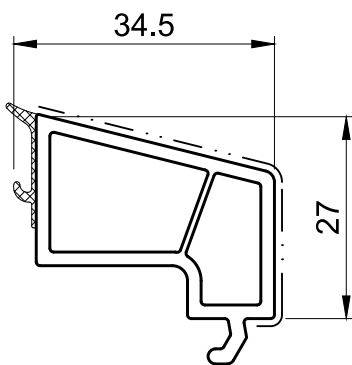

GP8280

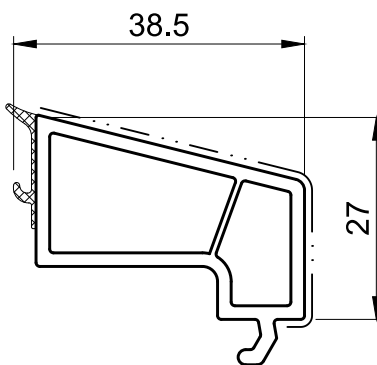

GP8240

Glazing-beads curve

27 mm

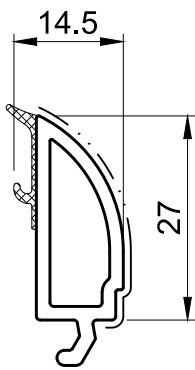

**GP9480**

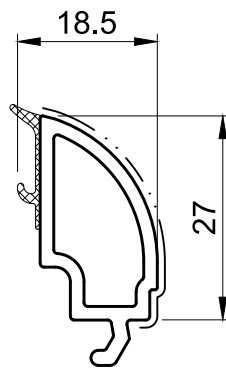

**GP9440**

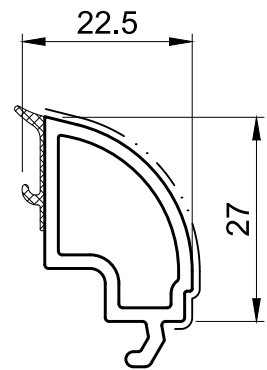

**GP9400**

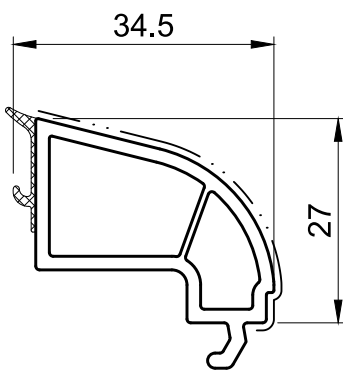

**GP9280**

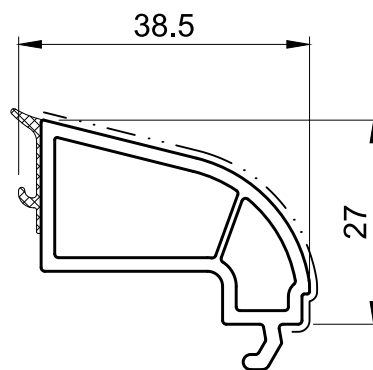

**GP9240**

Dry glazing table

27 mm

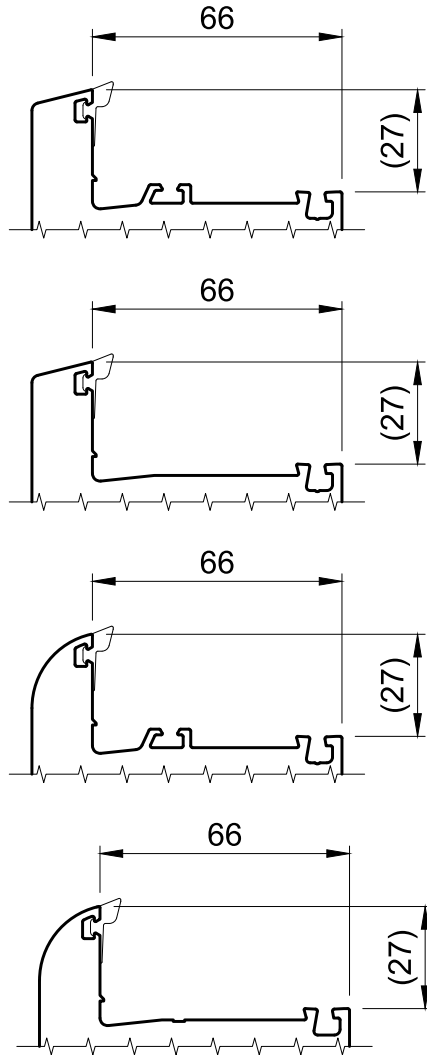

**Frame / fixed mullion / sash / glazing bar**

This table is based on calculated dimensions. Glass thickness tolerances and profile tolerances have not been taken into consideration. A glazing test must be performed before glazing.



Glass thickness in mm

Glazing-beads 27 mm

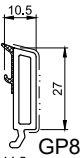
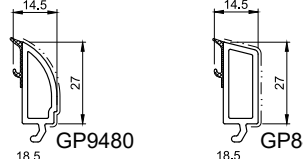
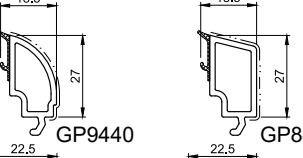
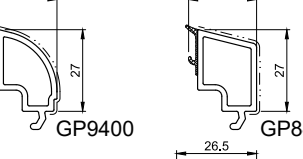
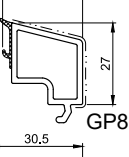
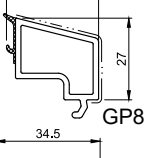
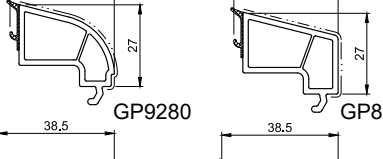
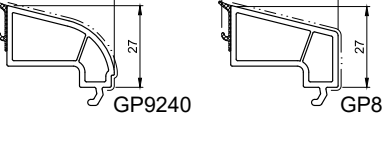
	 (WD) (A) (C) (E)	 (F)
 GP8520	51 - 52 - 53	49 - 50 - 51
 GP9480      GP8480	47 - 48 - 49	45 - 46 - 47
 GP9440      GP8440	43 - 44 - 45	41 - 42 - 43
 GP9400      GP8400	39 - 40 - 41	37 - 38 - 39
 GP8360	35 - 36 - 37	33 - 34 - 35
 GP8320	31 - 32 - 33	29 - 30 - 31
 GP9280      GP8280	27 - 28 - 29	25 - 26 - 27
 GP9240      GP8240	23 - 24 - 25	21 - 22 - 23

- (WD) = Gasket fitted ex-works
- (A) = DP8110 PVC-P
- (C) = DP8410 PVC-P
- (E) = DP8160 EPDM
- (F) = DP8480 EPDM

Glazing-beads

24 mm

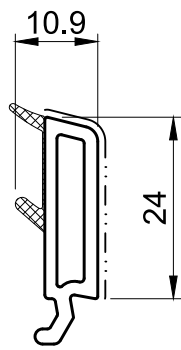

413301

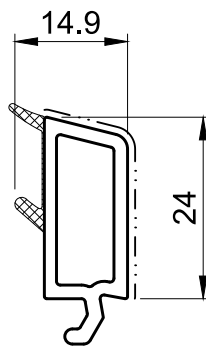

413303

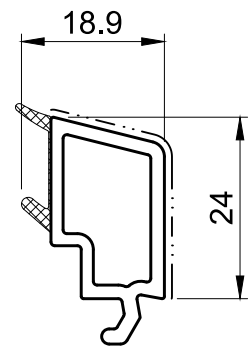

413305

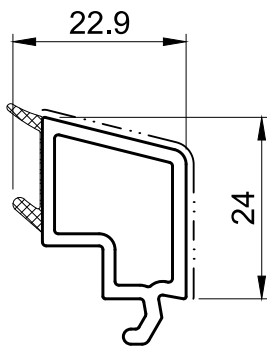

413307

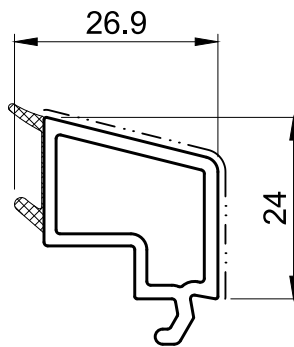

413309

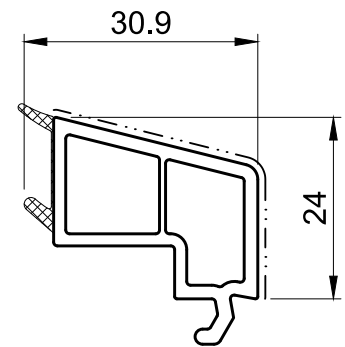

413311

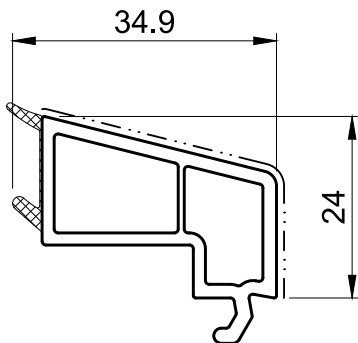

413313

Glazing-beads curve

24 mm

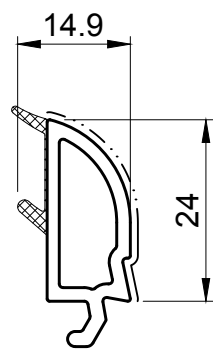

413103

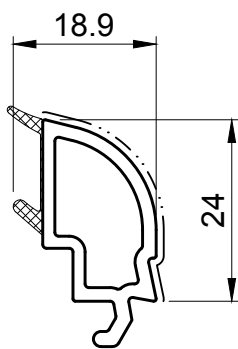

413105

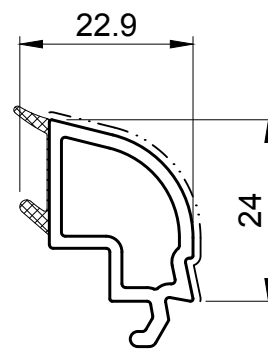

413107

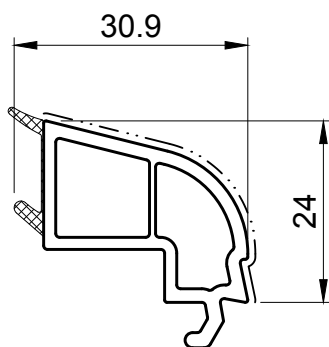

413111

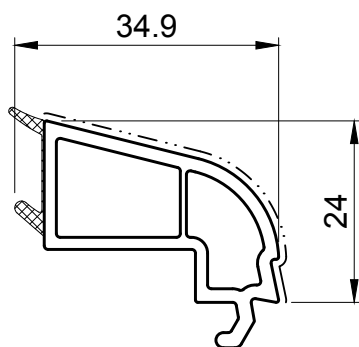

413113

Dry glazing table  
24 mm

Frame / fixed mullion /  
sash / glazing bar

This table is based on calculated dimensions. Glass thickness tolerances and profile tolerances have not been taken into consideration. A glazing test must be performed before glazing.

	Glass thickness in mm	
	 Glazing-beads 24 mm 	
	 413301	51 - 52 - 53      49 - 50 - 51
	 413103 413303	47 - 48 - 49      45 - 46 - 47
	 413105 413305	43 - 44 - 45      41 - 42 - 43
	 413107 413307	39 - 40 - 41      37 - 38 - 39
	 413309	35 - 36 - 37      33 - 34 - 35
	 413111 413311	31 - 32 - 33      29 - 30 - 31
	 413113 413313	27 - 28 - 29      25 - 26 - 27

- Ⓜ = Gasket fitted ex-works
- Ⓐ = DP8110 PVC-P
- Ⓒ = DP8410 PVC-P
- Ⓔ = DP8160 EPDM
- Ⓕ = DP8480 EPDM

Glass bar

19 mm

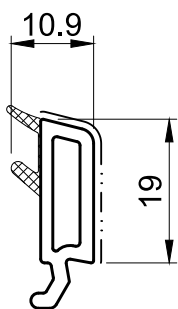

413001

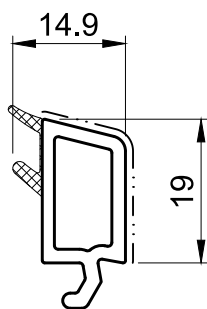

413003

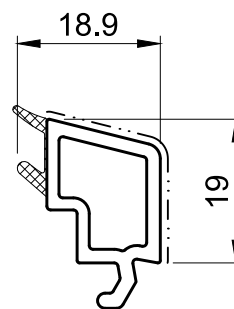

413005

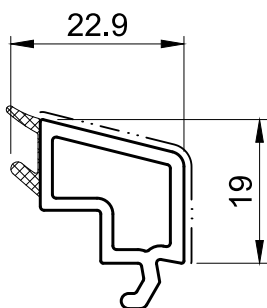

413007

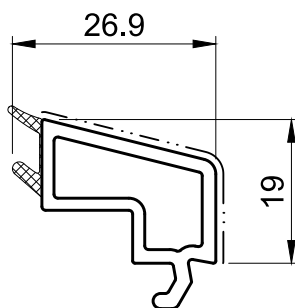

413009

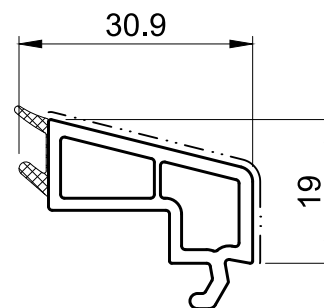

413011

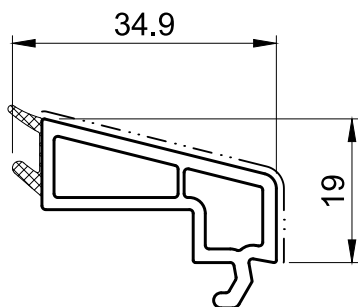

413013

Glass bar box

19 mm

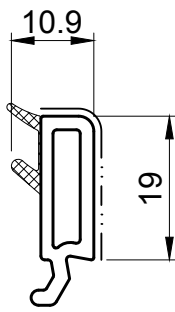

413201

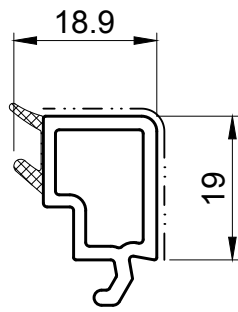

413205

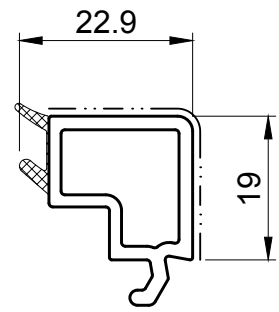

413207

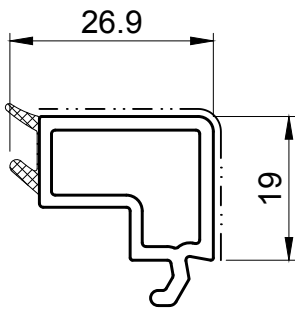

413209

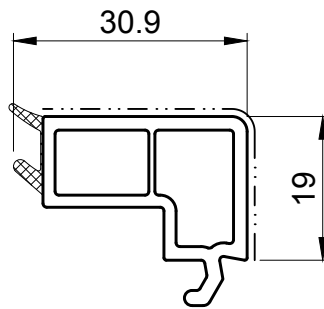

413211



Dry glazing table

19 mm

Sash / Mullion

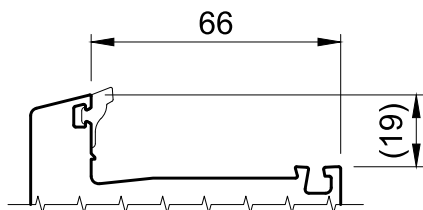
This table is based on calculated dimensions. Glass thickness tolerances and profile tolerances have not been taken into consideration. A glazing test must be performed before glazing.

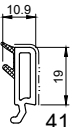
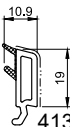
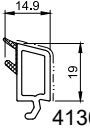
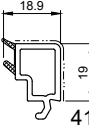
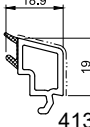
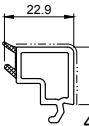
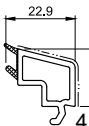
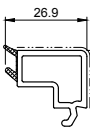
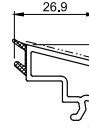
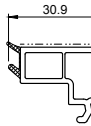
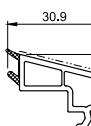
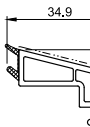

Glazing-beads 19 mm		Glass thickness in mm	
		 (WD) (A) (D) (F)	 (E)
 413201	 413001	51 - 52 - 53	49 - 50 - 51
	 413003	47 - 48 - 49	45 - 46 - 47
 413205	 413005	43 - 44 - 45	41 - 42 - 43
 413207	 413007	39 - 40 - 41	37 - 38 - 39
 413209	 413009	35 - 36 - 37	33 - 34 - 35
 413211	 413011	31 - 32 - 33	29 - 30 - 31
	 413013	27 - 28 - 29	25 - 26 - 27

- (WD) = Gasket fitted ex-works
- (A) = DP8110 PVC-P
- (C) = DP8410 PVC-P
- (E) = DP8160 EPDM
- (F) = DP8480 EPDM

Overlap 27 mm

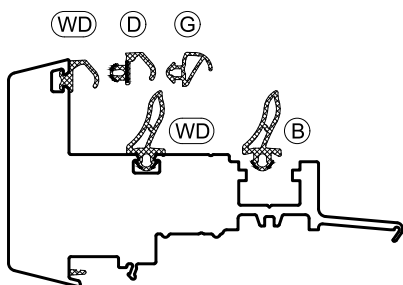
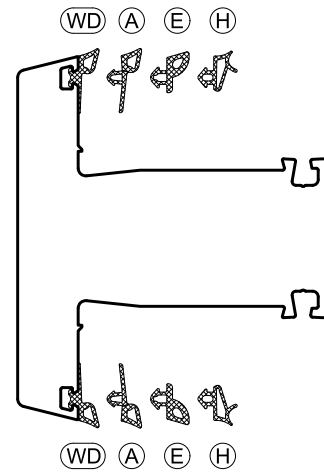
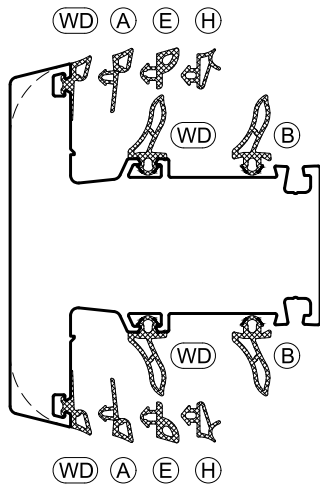
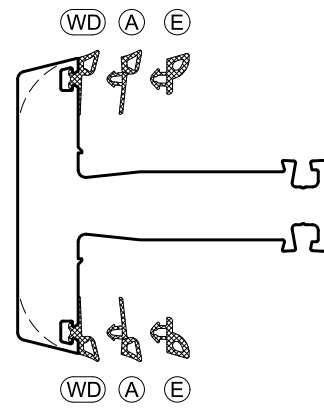
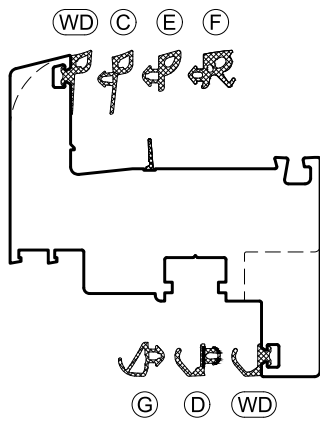
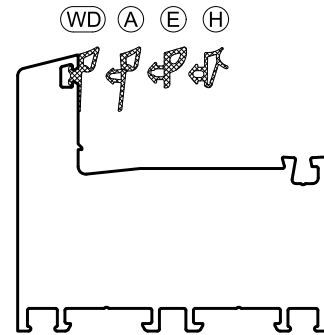
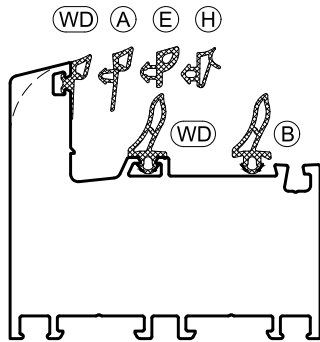

WD = ex-works gasket

A = DP8110 (PVC-P)

B = DP9110 (PVC-P)

C = DP8410 (PVC-P)

D = DP8610 (PVC-P)

E = DP8160 (EPDM)

F = DP8480 (EPDM)

G = DP8660 (EPDM)

H = DP8865 (EPDM)

Gaskets

PVC-P

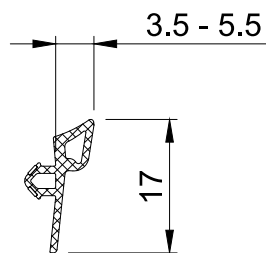

**DP8110**

Stop and glazing gasket  
for frames, fixed mullions, glazing bar  
Colour: black, grey

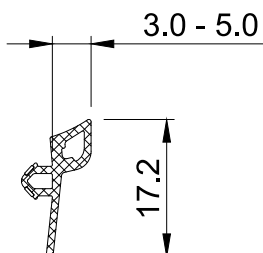

**DP8410**

Glazing gasket  
for sashes  
Colour: black, grey

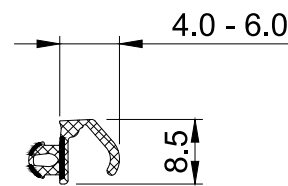

**DP8610**

Stopper gasket  
for sash, faceplate  
Colour: black, grey

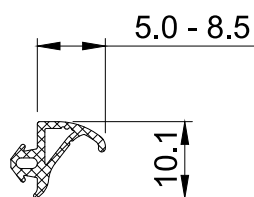

**DP8860**

Main door stopper gasket  
for frames, fixed mullions, sashes  
Colour: black, grey

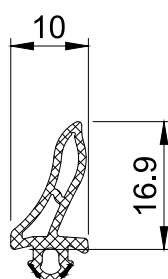

**DP9110**

Central gasket  
for frame, fixed mullion, faceplate  
Colour: black, grey

EPDM

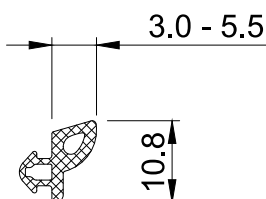

**DP8160**

Stop and glazing gasket  
for frames, fixed mullions, sashes  
Colour: black, grey

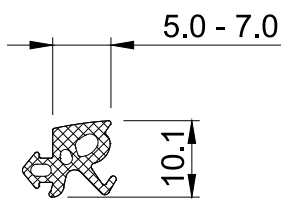

**DP8480**

Glazing gasket  
for sashes  
Colour: black, grey

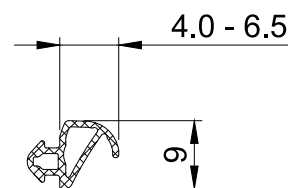

**DP8660**

Stopper gasket  
for sash, faceplate  
Colour: black, grey

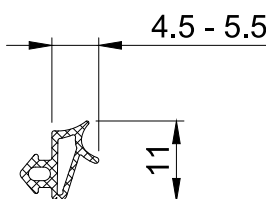

**DP8865**

Main door stopper gasket  
for frames, fixed mullions  
Colour: black, grey

## Overlap 19 mm

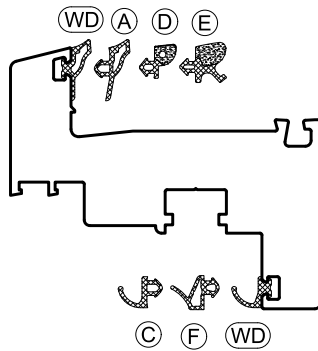

ⓂWD = ex-works gasket

ⓂA = 464100 (PVC-P)

ⓂB = 464102 (PVC-P)

ⓂC = 464101 (PVC-P)

ⓂD = 414566 (EPDM)

ⓂE = 414573 (EPDM)

ⓂF = 464203 (EPDM)

Gaskets

PVC-P

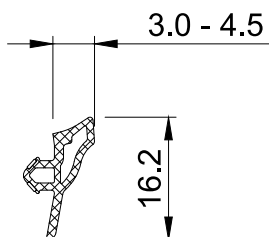

**464100**

Combination gasket  
for frame, sash, glazing bar, fixed  
mullion

Colour: black, grey

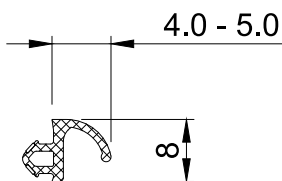

**464101**

Stopper gasket  
for sash, faceplate

Colour: black, grey

EPDM

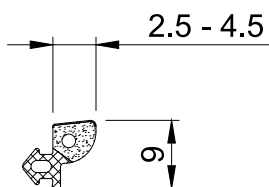

**414566**

Glazing gasket  
for frames, sashes, fixed mullions

Colour: black, grey

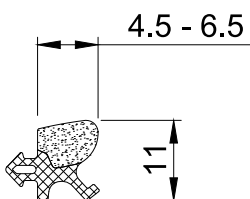

**414573**

Glazing gasket  
for frame, sash, glazing bar, fixed  
mullion

Colour: black, grey

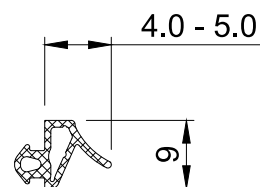

**464203**

Stopper gasket  
for frames, sashes, fixed mullions

Colour: black, grey

Brush seals, miscellaneous gaskets

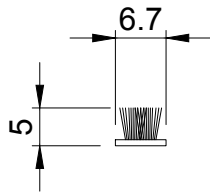

**404930**  
Brush seal  
for roller shutter guide  
Colour: black, grey

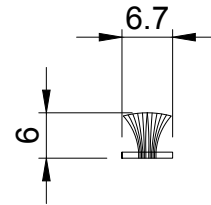

**404935**  
Brush seal  
for roller shutter guide  
Colour: black, grey

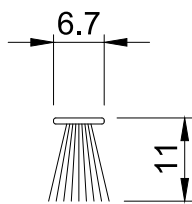

**DP7010**  
Brush seal  
for weather profile strip door threshold  
Colour: grey

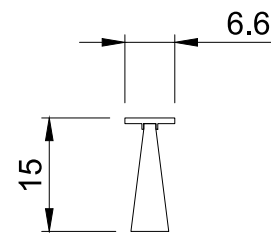

**414971**  
Brush seal  
for weather profile strip door threshold  
Colour: grey

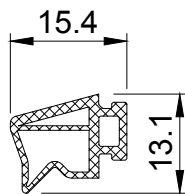

**DP7230**  
Silicone stopper gasket  
for weather profile strips  
Colour: black, grey

Glass rebate bridges

**GZ8010, GZ9010**

Glass blocks

**417212 - 417265**

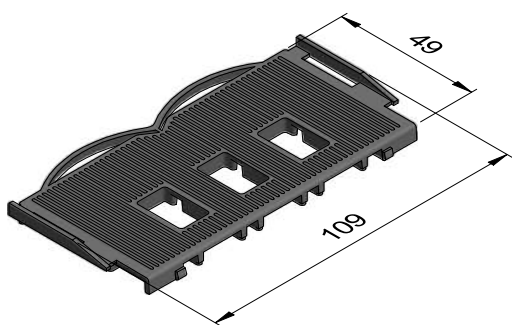

**Glass rebate bridge  
GZ8010**

for AD frames, fixed mullions and sashes

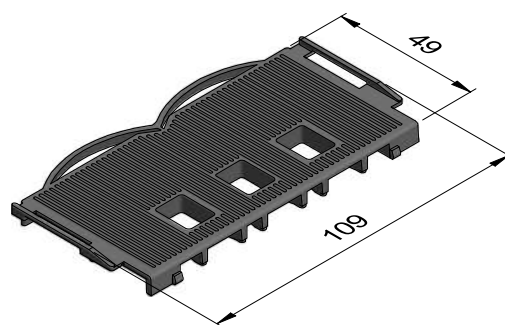

**Glass rebate bridge  
GZ9010**

for MD frames, fixed mullions and sashes

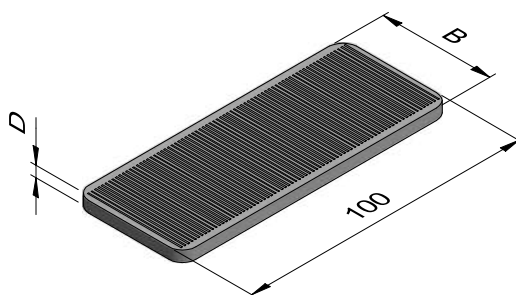

Article no.	Width B	Thickness D
<b>417212 – 417216</b>	30 mm	2 - 6 mm
<b>417222 – 417226</b>	34 mm	2 - 6 mm
<b>417232 – 417235</b>	40 mm	2 - 5 mm
<b>417242 – 417245</b>	48 mm	2 - 5 mm
<b>417252 – 417255</b>	50 mm	2 - 5 mm
<b>417262 – 417265</b>	52 mm	2 - 5 mm

Strengthenings

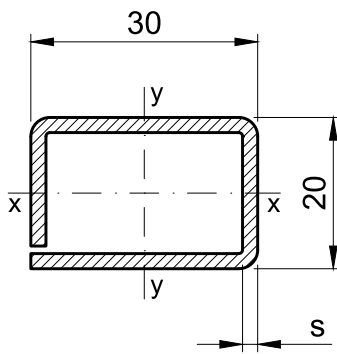

**105011**

Key number	Thickness s (mm)	Ix (cm <sup>4</sup> )	Iy (cm <sup>4</sup> )	Weight (g/m)
73	1.5	0.86	1.63	Approx. 1076
74	2.0	1.07	2.04	Approx. 1398
Application	HO9120			

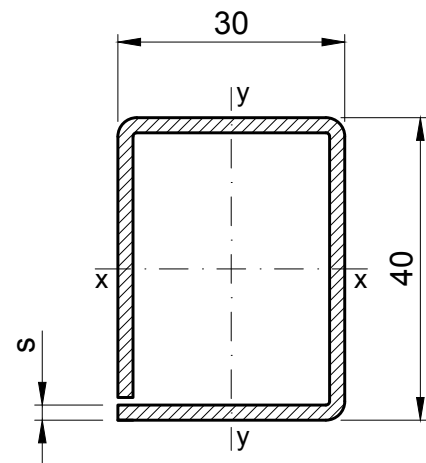

**405040**

Key number	Thickness s (mm)	Ix (cm <sup>4</sup> )	Iy (cm <sup>4</sup> )	Weight (g/m)
73	1.5	4.49	2.87	Approx. 1555
74	2.0	5.72	3.63	Approx. 2037
Application	HO8030			

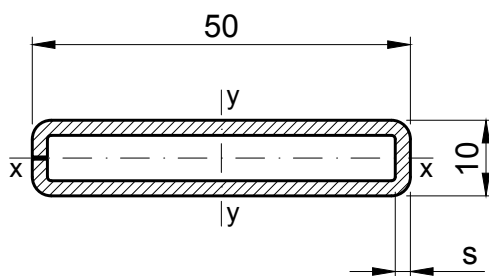

**405015**

Key number	Thickness s (mm)	Ix (cm <sup>4</sup> )	Iy (cm <sup>4</sup> )	Weight (g/m)
73	1.5	0.27	4.06	Approx. 1303
74	2.0	0.32	5.20	Approx. 1713
Use	NP8120, NP8170, RF3220			

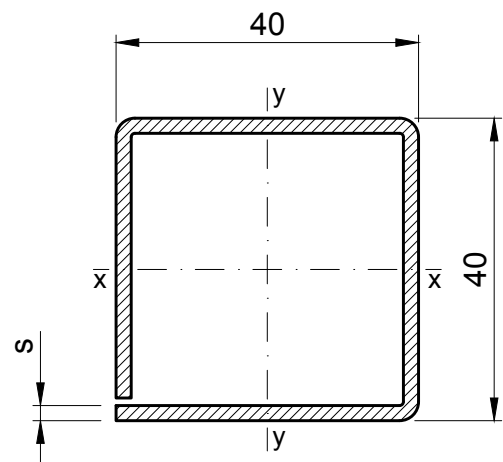

**405060**

Key number	Thickness s (mm)	Ix (cm <sup>4</sup> )	Iy (cm <sup>4</sup> )	Weight (g/m)
73	1.5	5.61	5.61	Approx. 1791
74	2.0	7.17	7.17	Approx. 2351
Application	NP0100			

Strengthenings

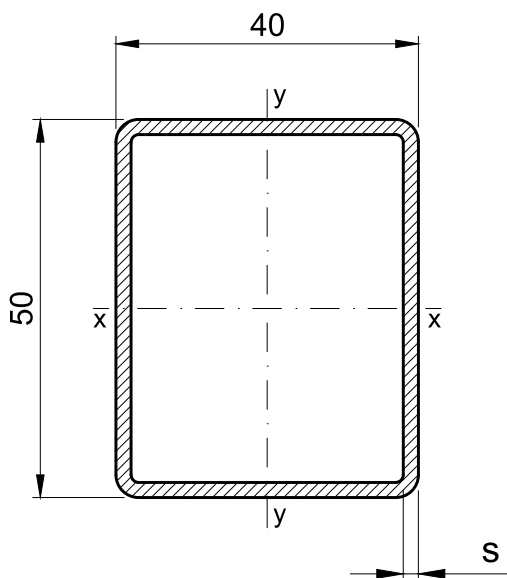

**405065**

Key number	Thickness s (mm)	Ix (cm <sup>4</sup> )	Iy (cm <sup>4</sup> )	Weight (g/m)
74	2.0	12.05	8.52	Approx. 2646
Application	HO9330			

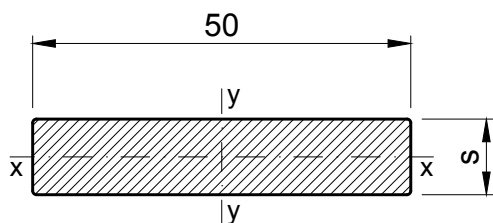

**405125**

Key number	Thickness s (mm)	Ix (cm <sup>4</sup> )	Iy (cm <sup>4</sup> )	Weight (g/m)
	10.0	0.42	10.40	Approx. 3923
Use	NP8170			

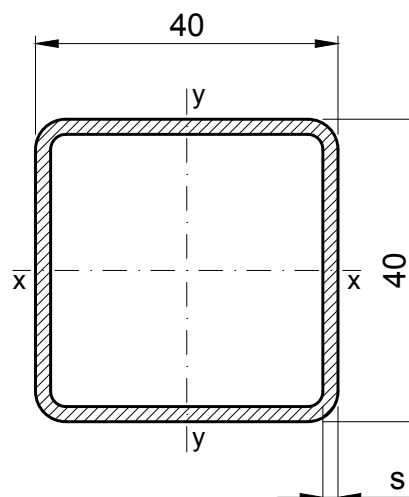

**415040**

Key number	Thickness s (mm)	Ix (cm <sup>4</sup> )	Iy (cm <sup>4</sup> )	Weight (g/m)
74	2.0	6.94	6.94	Approx. 2306
Application	NP8700, HO9340			

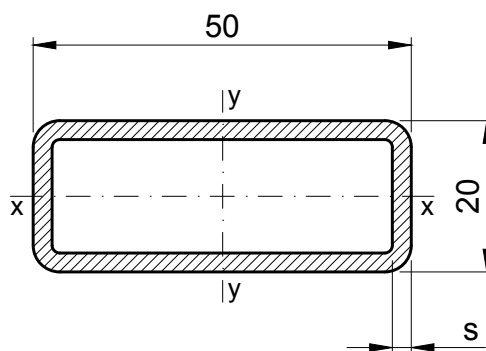

**475021**

Key number	Thickness s (mm)	Ix (cm <sup>4</sup> )	Iy (cm <sup>4</sup> )	Weight (g/m)
75	2.5	1.98	8.86	Approx. 2475
Application	HO9310, HO8310			

Strengthenings

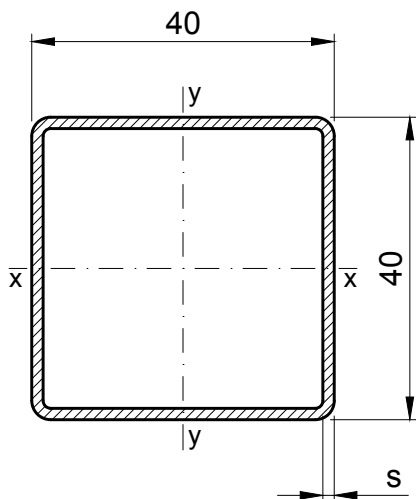

**715303**

Key number	Thickness s (mm)	Ix (cm <sup>4</sup> )	Iy (cm <sup>4</sup> )	Weight (g/m)
73	1.5	5.60	5.60	Approx. 1778
Application	NP8700			

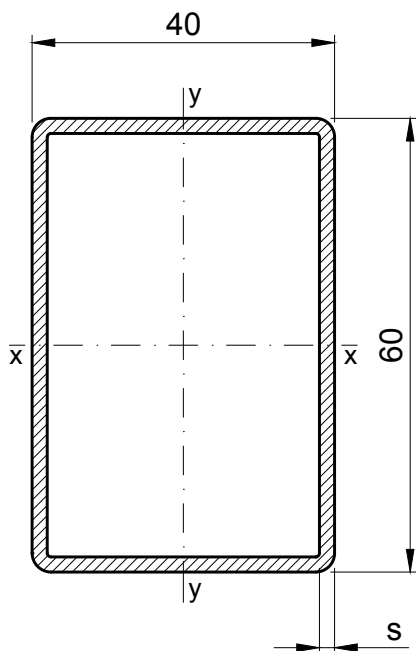

**AR4630**

Key number	Thickness s (mm)	Ix (cm <sup>4</sup> )	Iy (cm <sup>4</sup> )	Weight (g/m)
74	2.0	18.87	10.03	Approx. 2972
Use	HP8550, HP8560, HO8580			

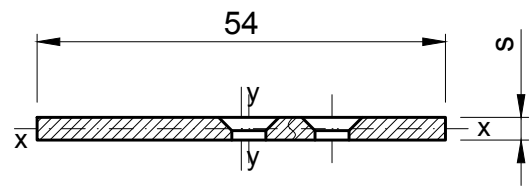

**MT8500**

Key number	Thickness s (mm)	Ix (cm <sup>4</sup> )	Iy (cm <sup>4</sup> )	Weight (g/m)
76	3.0	0.01	3.93	Approx. 1272
Application	HO8520, HP8920, HO8530, HP8930, HP8540, HP8550, HP8560			

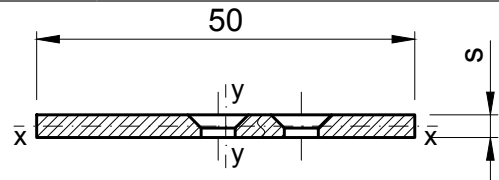

**465022**

Key number	Thickness s (mm)	Ix (cm <sup>4</sup> )	Iy (cm <sup>4</sup> )	Weight (g/m)
76	3.0	0.01	3.13	Approx. 5281
Application	HO8590			

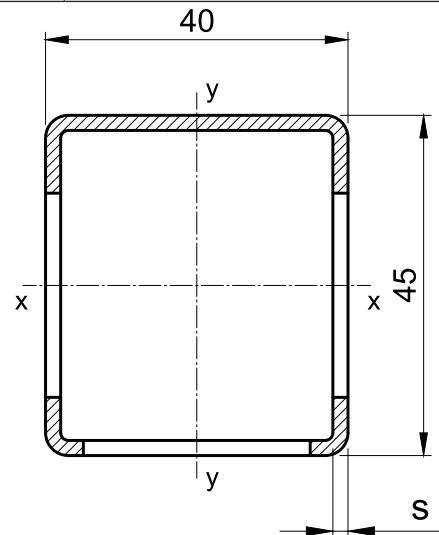

**MT8530**

Key number	Thickness s (mm)	Ix (cm <sup>4</sup> )	Iy (cm <sup>4</sup> )	Weight (g/m)
74	2.0	8.59	7.84	Approx. 2489
Use	HO8530, HP8930, HO8540			

Strengthenings

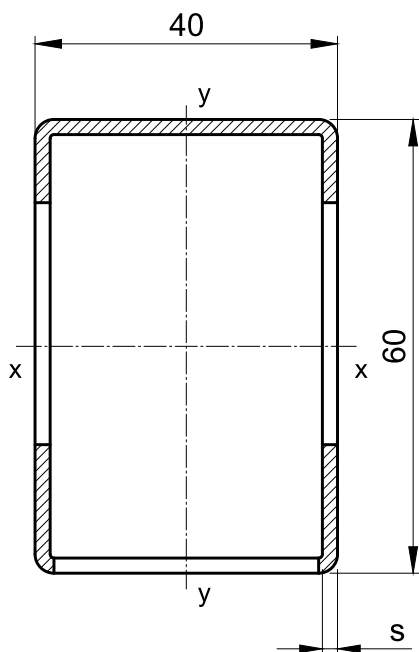

**MT8551**

Key number	Thickness s (mm)	Ix (cm <sup>4</sup> )	Iy (cm <sup>4</sup> )	Weight (g/m)
74	2.0	18.86	10.03	Approx. 2916
Use	HP8550, HP8560, HO8580			

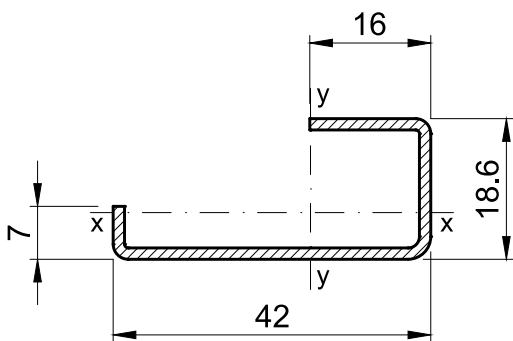

**VS1010**

Key number	Thickness s (mm)	Ix (cm <sup>4</sup> )	Iy (cm <sup>4</sup> )	Weight (g/m)
73	1.5	0.57	2.25	Approx. 907
Application	NP1350, NP3300, NP3280			

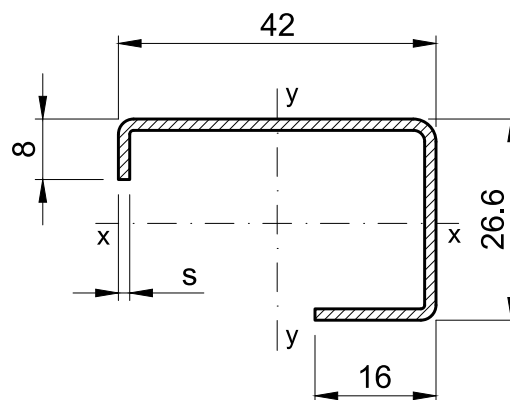

**VS1020**

Key number	Thickness s (mm)	Ix (cm <sup>4</sup> )	Iy (cm <sup>4</sup> )	Weight (g/m)
73	1.5	1.32	2.61	Approx. 1013
Application	NP1550, NP3300, NP3280			

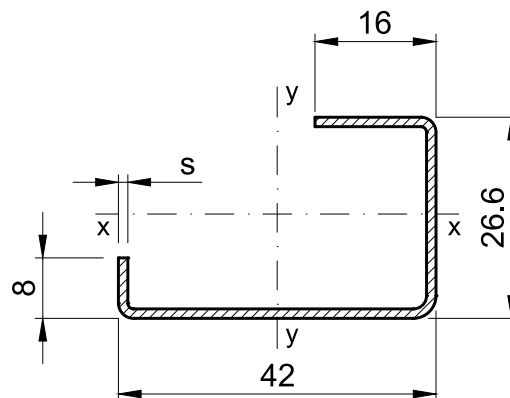

**VS1120**

Key number	Thickness s (mm)	Ix (cm <sup>4</sup> )	Iy (cm <sup>4</sup> )	Weight (g/m)
72	1.25	1.13	2.21	Approx. 850
Application	NP1550, NP3300, NP3280			

Strengthenings

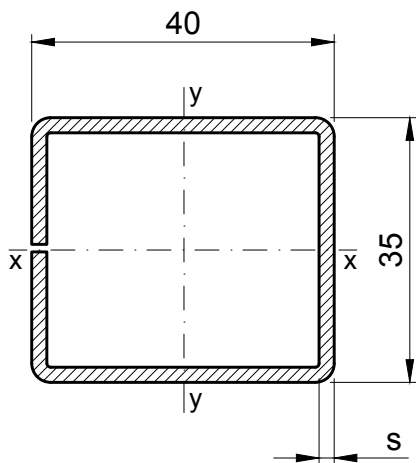

**VS3030**

Key number	Thickness s (mm)	Ix (cm <sup>4</sup> )	Iy (cm <sup>4</sup> )	Weight (g/m)
74	2.0	5.21	6.35	Approx. 2173
Application		NP8500, NP8700		

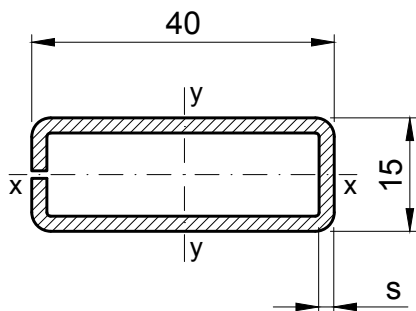

**VS4020**

Key number	Thickness s (mm)	Ix (cm <sup>4</sup> )	Iy (cm <sup>4</sup> )	Weight (g/m)
74	2.0	0.70	3.45	Approx. 1545
Application		NP8300, NP8700		

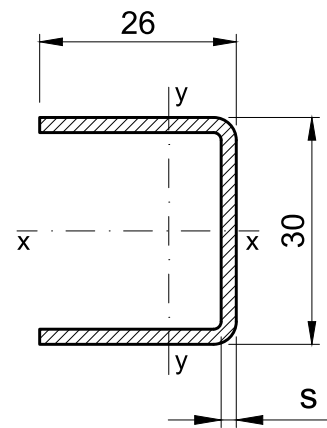

**VS8020**

Key number	Thickness s (mm)	Ix (cm <sup>4</sup> )	Iy (cm <sup>4</sup> )	Weight (g/m)
73	1.5	1.77	0.82	Approx. 907
74	2.0	2.26	1.06	Approx. 1198
Application		HO9020, HP9220, HO8020, HO8520, HP8920, HO9320; HP9420, HO8320, HO9800, HO8800, HO9850, HO9110, HO9100, HO9021, HO8021, HO8521		

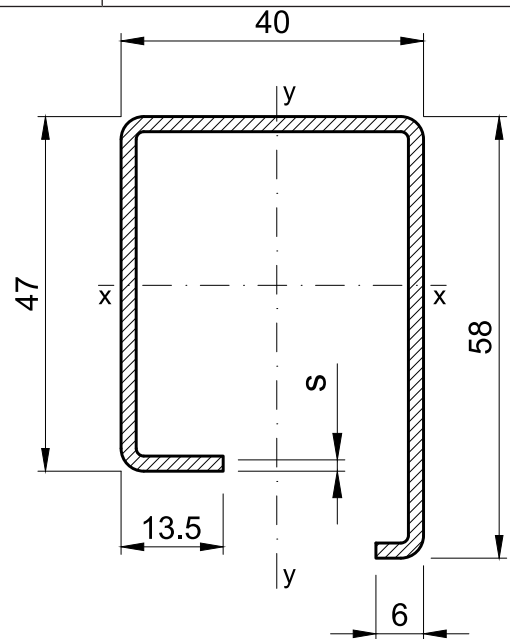

**VS8030**

Key number	Thickness s (mm)	Ix (cm <sup>4</sup> )	Iy (cm <sup>4</sup> )	Weight (g/m)
73	1.5	8.36	6.76	Approx. 1833
74	2.0	10.72	8.69	Approx. 2413
Application		HO8530, HP8930		

Strengthenings

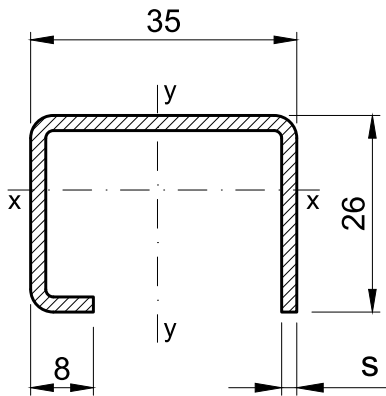

**VS8050**

Key number	Thickness s (mm)	I <sub>x</sub> (cm <sup>4</sup> )	I <sub>y</sub> (cm <sup>4</sup> )	Weight (g/m)
74	2.0	1.40	3.41	Approx. 1365
Application	HO8520, HP8920, HO8521			

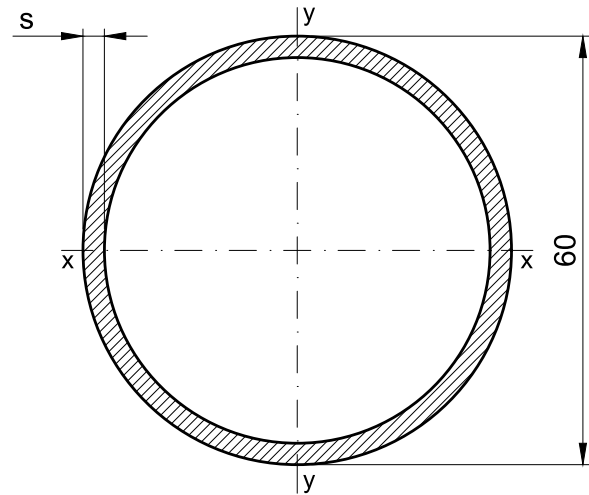

**VS8160**

Key number	Thickness s (mm)	I <sub>x</sub> (cm <sup>4</sup> )	I <sub>y</sub> (cm <sup>4</sup> )	Weight (g/m)
76	3.0	21.88	21.88	Approx. 4217
Application	NP8160			

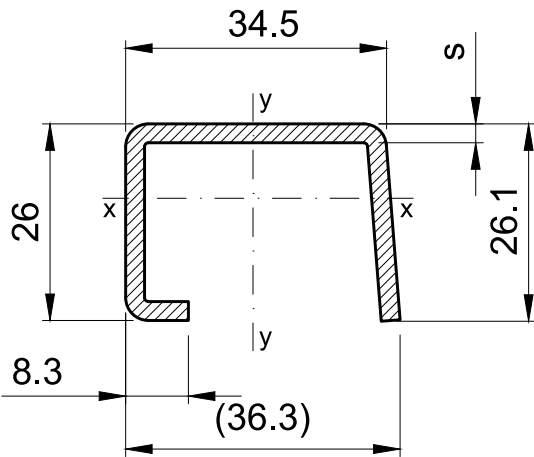

**VS8055**

Key number	Thickness s (mm)	I <sub>x</sub> (cm <sup>4</sup> )	I <sub>y</sub> (cm <sup>4</sup> )	Weight (g/m)
75	2.5	1.65	4.09	Approx. 1670
Application	HO8520, HP8920, HO8521			

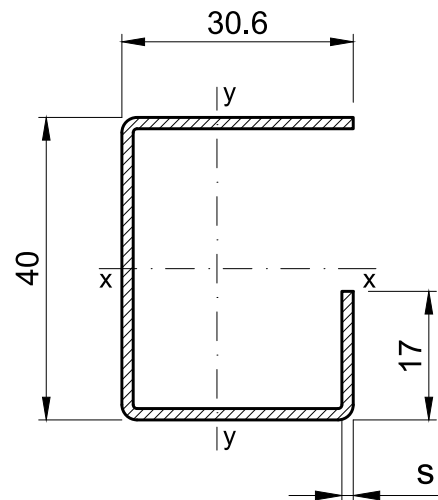

**VS8230**

Key number	Thickness s (mm)	I <sub>x</sub> (cm <sup>4</sup> )	I <sub>y</sub> (cm <sup>4</sup> )	Weight (g/m)
73	1.5	4.23	2.21	Approx. 1320
Application	HO8030			

Strengthenings

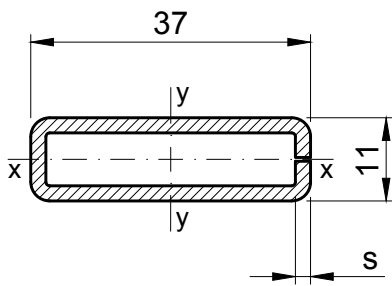

**VS8300**

Key number	Thickness s (mm)	Ix (cm <sup>4</sup> )	Iy (cm <sup>4</sup> )	Weight (g/m)
74	2.0	0.30	2.35	Approx. 1333
Application	HO8300			

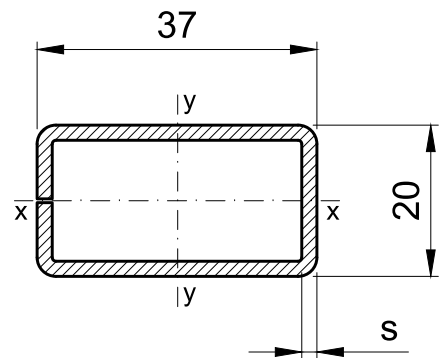

**VS8320**

Key number	Thickness s (mm)	Ix (cm <sup>4</sup> )	Iy (cm <sup>4</sup> )	Weight (g/m)
74	2.0	1.29	3.45	Approx. 1616
Application	HO9320, HP9420, HO8320			

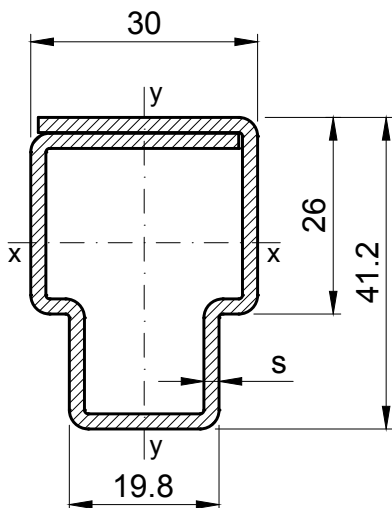

**VS8310**

Key number	Thickness s (mm)	Ix (cm <sup>4</sup> )	Iy (cm <sup>4</sup> )	Weight (g/m)
74	2.0	6.40	3.20	Approx. 2412
Application	HO9310, HO8310			

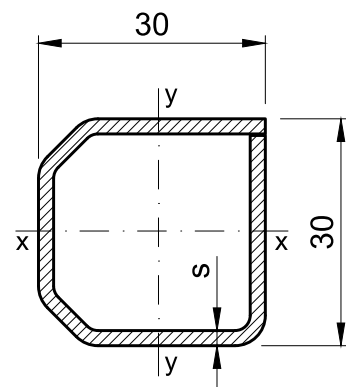

**VS8420**

Key number	Thickness s (mm)	Ix (cm <sup>4</sup> )	Iy (cm <sup>4</sup> )	Weight (g/m)
74	2.0	2.54	2.52	Approx. 1624
Application	HO9020, HO9021, HP9220, HO9100, HO9110, HO8020, HO8021, HO8030			

Strengthenings

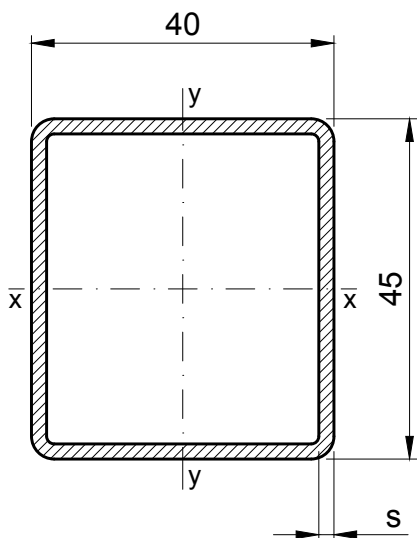

**VS8450**

Key number	Thickness s (mm)	Ix (cm <sup>4</sup> )	Iy (cm <sup>4</sup> )	Weight (g/m)
74	2.0	7.80	9.36	Approx. 2489
Use	HO8530, HP8930, HO8540			

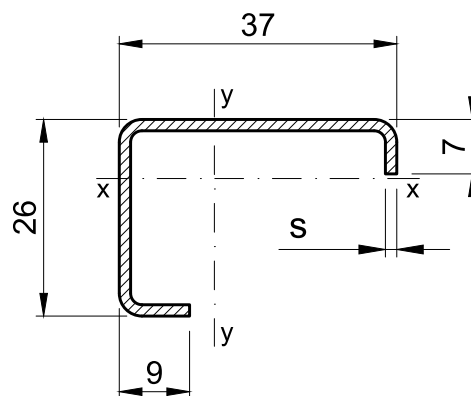

**VS8520**

Key number	Thickness s (mm)	Ix (cm <sup>4</sup> )	Iy (cm <sup>4</sup> )	Weight (g/m)
73	1.5	0.89	1.72	Approx. 845
Application	HO8520, HO8570, HP8920, HO8521			

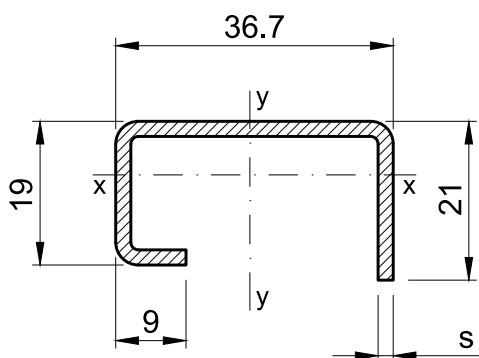

**VS8510**

Key number	Thickness s (mm)	Ix (cm <sup>4</sup> )	Iy (cm <sup>4</sup> )	Weight (g/m)
73	1.5	0.58	2.43	Approx. 933
74	2.0	0.72	3.07	Approx. 1216
Application	HO8510			

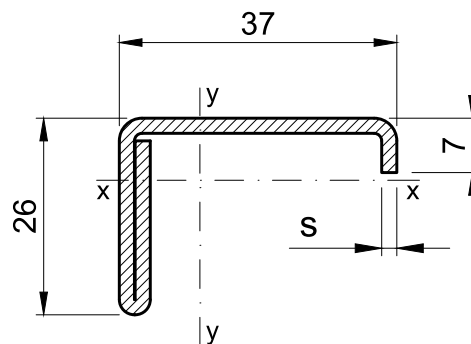

**VS8620**

Key number	Thickness s (mm)	Ix (cm <sup>4</sup> )	Iy (cm <sup>4</sup> )	Weight (g/m)
74	2.0	1.11	2.48	Approx. 1357
Application	HO8520, HO8570, HP8920, HO8521			

Strengthenings

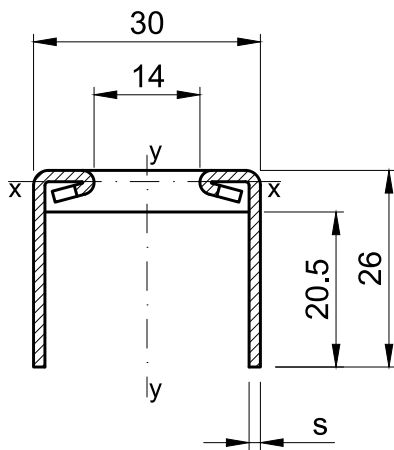

**VS9029**

Key number	Thickness s (mm)	Ix (cm <sup>4</sup> )	Iy (cm <sup>4</sup> )	Weight (g/m)
73	1.5	0.74	1.90	Approx. 1035
Application	HO8520, HO8521, HP8920			

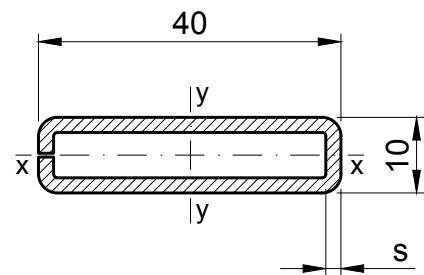

**VS9810**

Key number	Thickness s (mm)	Ix (cm <sup>4</sup> )	Iy (cm <sup>4</sup> )	Weight (g/m)
74	2.0	0.26	2.77	Approx. 1396
Application	HO8810, HO9810			

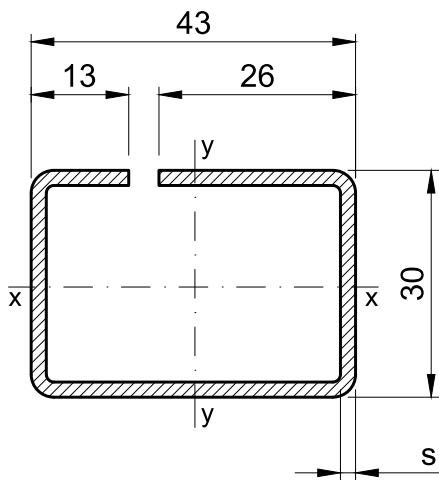

**VS9800**

Key number	Thickness s (mm)	Ix (cm <sup>4</sup> )	Iy (cm <sup>4</sup> )	Weight (g/m)
74	2.0	3.65	6.65	Approx. 2047
Application	HO8800, HO9800			

Weldable corner connector  
MT8540, MT4631

Clamping lever  
207910

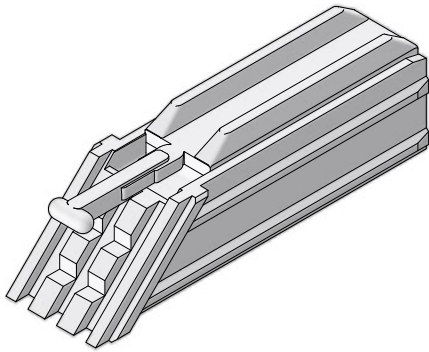

**MT8540**

Weldable corner connector  
for strengthenings VS8450, MT8530

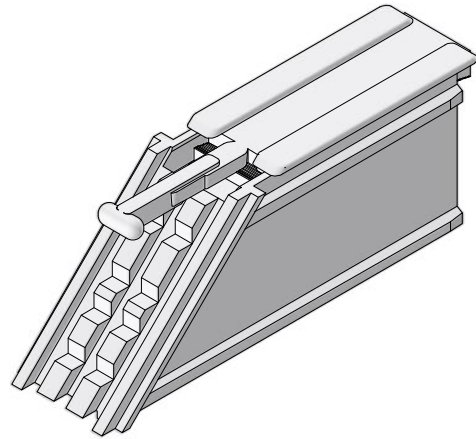

**MT4631**

Weldable corner connector  
for strengthenings AR4630, MT8551

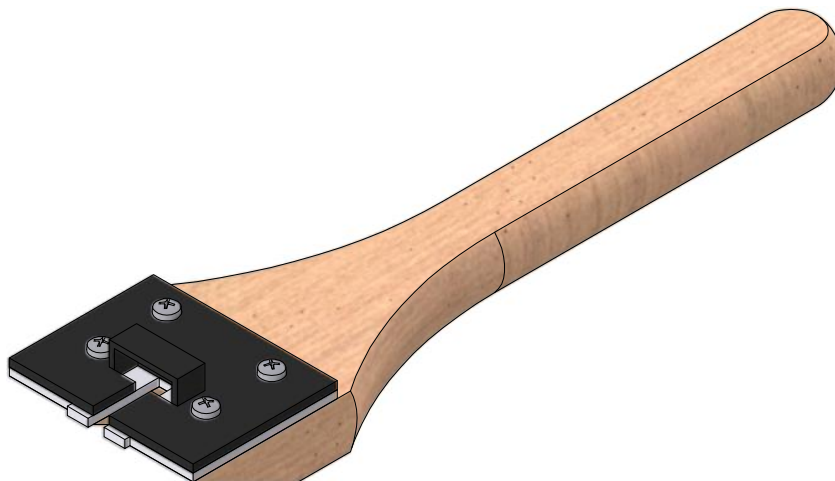

**207910**  
Clamping lever

Fixed-mullion connector, glazing bar connector

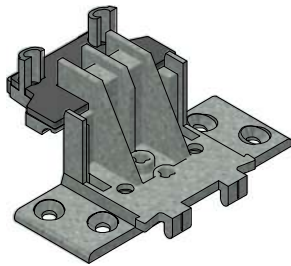

**ZS9321**

Fixed-mullion connector set MD  
for fixed mullions HO9320, HO9310, HP9420  
Drilling jig MT9901 (not depicted)

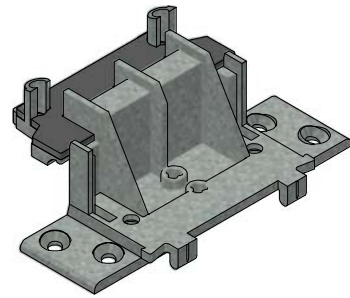

**ZS9341**

Fixed-mullion connector set MD  
for fixed mullions HO9340, HO9330  
Drilling jig MT9901 (not depicted)

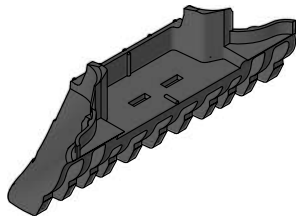

**MT9320**

Fixed mullion sealing block MD  
for fixed-mullion connectors ZS9321

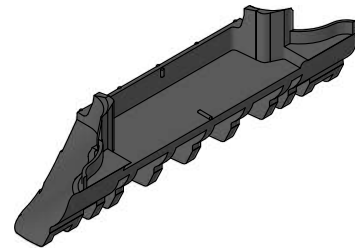

**MT9340**

Fixed mullion sealing block MD  
for fixed-mullion connectors ZS9341

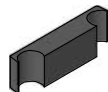

**MT9310**

Sealing pad fixed mullion MD  
for fixed mullion HO9310

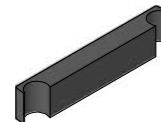

**MT9330**

Sealing pad fixed mullion MD  
for fixed mullion HO9330

Fixed-mullion connector, glazing bar connector

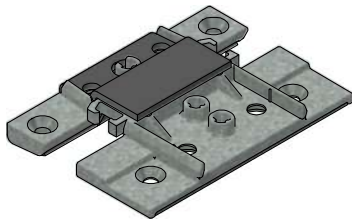

**ZS9320**

Fixed-mullion connector set MD  
for fixed mullions HO9320, HO9310, HP9420  
Drilling jig MT9900 (not depicted)

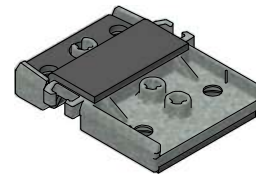

**ZS9420**

Fixed-mullion connector set MD  
for fixed mullions HO9320, HO9310, HP9420  
Drilling jig MT9900 (not depicted)

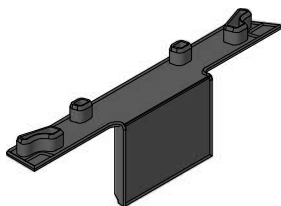

**MT8220**

Sealing block fixed mullion AD / MD  
for fixed-mullion connector set ZS9320, ZS9420,  
ZS8320, ZS8420

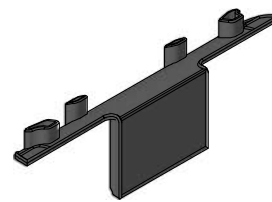

**MT8230**

Fixed mullion sealing block MD  
for fixed-mullion connector set ZS9320, ZS9420



**MT9010**

Sealing fitting  
for fixed mullions HO9320, HO9310, HP9420

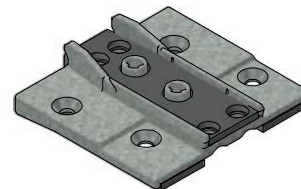

**ZS8300**

Glazing bar connector set AD  
for glazing bar HO8300  
Drilling jig MT9920 (not depicted)



**ZS8303**

Mullion connector set AD  
for glazing bar HO8300  
Drilling jig MT9920 (not depicted)

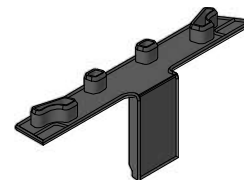

**MT8200**

Sealing block glazing bar AD  
for glazing bar connector set ZS8300, ZS8303

Fixed-mullion connector, glazing bar connector

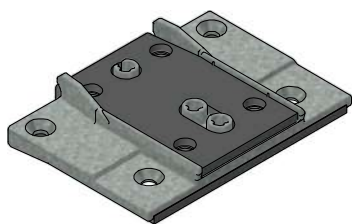

**ZS8320**

Fixed-mullion connector set AD  
for fixed mullions HO8320, HO8310  
Drilling jig MT9900 (not depicted)

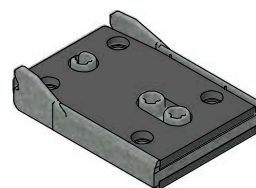

**ZS8420**

Fixed-mullion connector set AD  
for fixed mullions HO8320, HO8310  
Drilling jig MT9900 (not depicted)

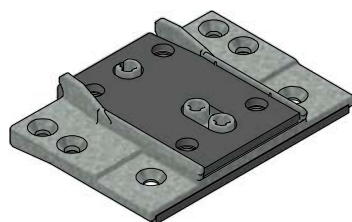

**ZS8323**

Fixed-mullion connector set AD  
for fixed mullions HO8320, HO8310  
Drilling jig MT9900 (not depicted)

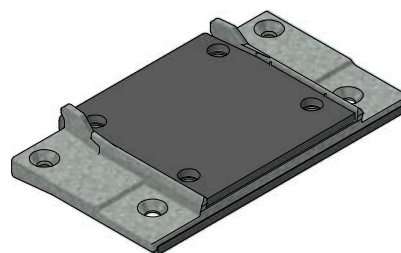

**ZS8340**

Fixed-mullion connector set AD  
for fixed mullions HO9340, HO9330  
Drilling jig MT9902 (not depicted)

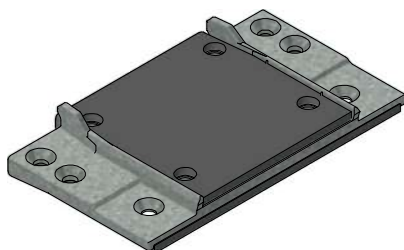

**ZS8343**

Fixed-mullion connector set AD  
for fixed mullions HO9340, HO9330  
Drilling jig MT9902 (not depicted)

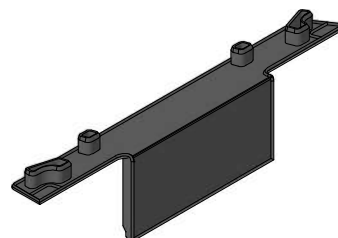

**MT8240**

Sealing block fixed mullion AD  
for fixed-mullion connector set ZS8340, ZS8343

Floating-mullion end cover caps

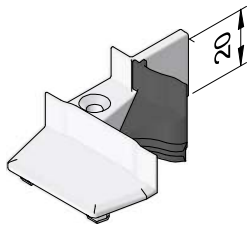

**ZS9820**

Faceplate end cover cap set MD  
for faceplate, right-angled profile HO9820



**ES9860**

Cover cap  
for faceplate, right-angled profile HO9820

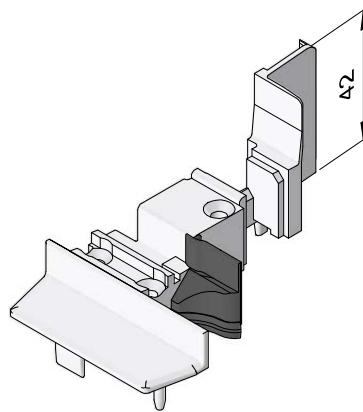

**ZS9811**

Faceplate end cover cap set MD  
for right-angled profile HO9810

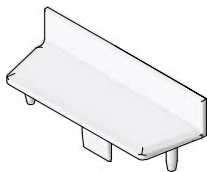

**ES9830**

Faceplate end cover cap outside  
for right-angled profile HO9810

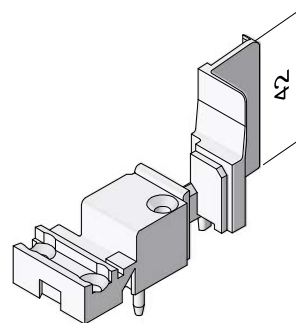

**ES9821**

Faceplate end cover cap inside  
for right-angled profile HO9810



**MT9800**

Sealing fitting

Floating-mullion end cover caps

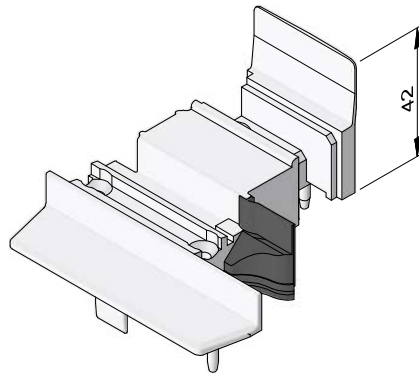

**ZS9801**

Faceplate end cover cap set MD  
for right-angled profile HO9800

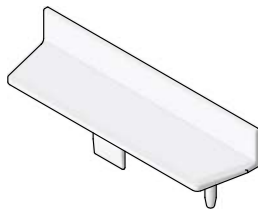

**ES9810**

Faceplate end cover cap outside  
for right-angled profile HO8800, HO9800

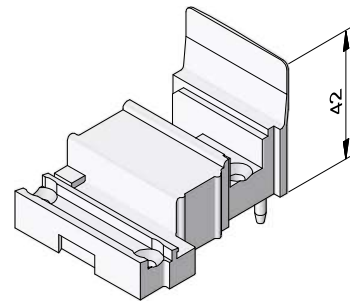

**ES9801**

Faceplate end cover cap inside  
for right-angled profile HO8800, HO9800, HO9850



**MT9800**

Sealing fitting

Floating-mullion end cover caps

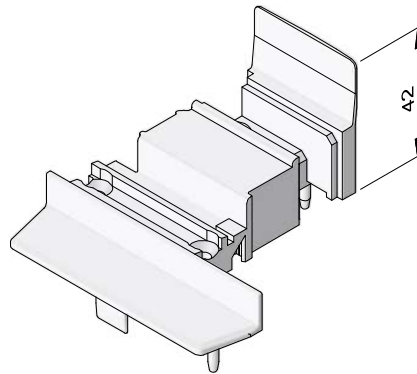

**ZS8801**

Faceplate end cover cap set  
for right-angled profile HO8800

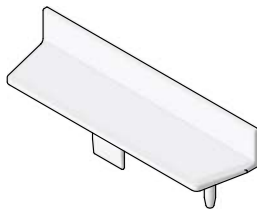

**ES9810**

Faceplate end cover cap outside  
for right-angled profile HO8800, HO9800

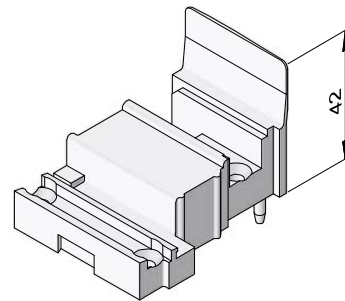

**ES9801**

Faceplate end cover cap inside  
for right-angled profile HO8800, HO9800, HO9850

Floating-mullion end cover caps

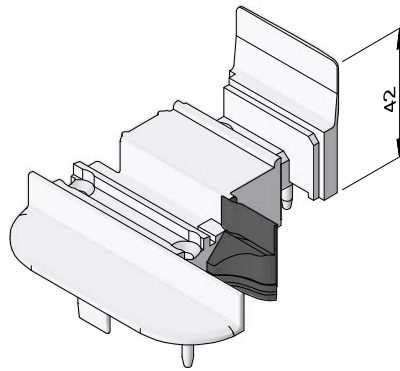

**ZS9851**

Faceplate end cover cap set MD  
for right-angled profile HO9850

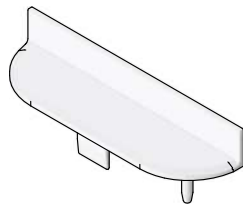

**ES9850**

Faceplate end cover cap outside  
for right-angled profile HO9850

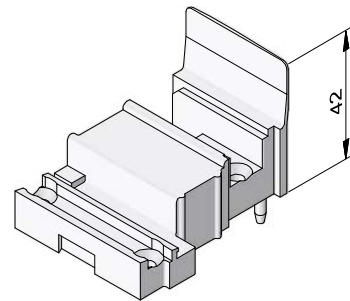

**ES9801**

Faceplate end cover cap inside  
for right-angled profile HO8800, HO9800, HO9850



**MT9800**

Sealing fitting

Door thresholds  
**ZS7110, ZS7120**

Cover profile  
**NP7120**

Attachment profile  
**VA7125**

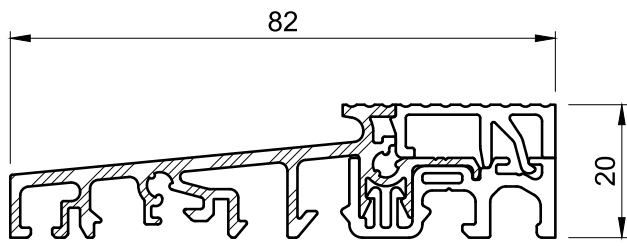

**ZS7110**  
 Door threshold

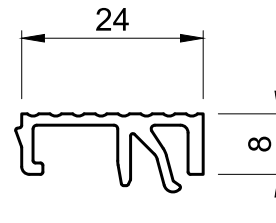

**NP7120**  
 Cover profile

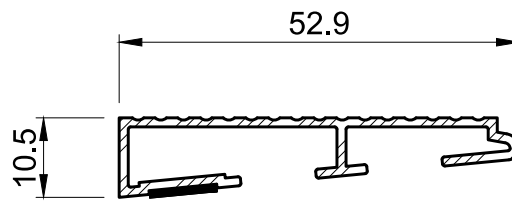

**VA7125**  
 Attachment profile for ZS7110

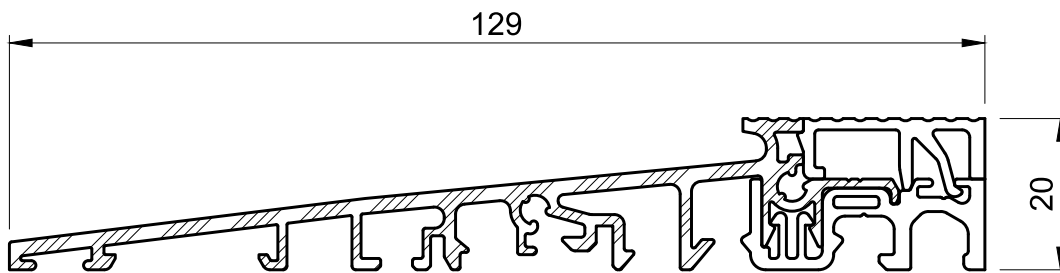

**ZS7120**  
 Door threshold

Door thresholds  
**ZS7125, ZS7130**

Weather profile strip  
**VA7231**

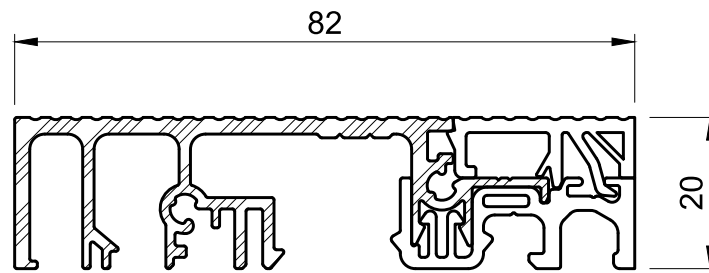

**ZS7125**  
 Door threshold  
 (Outward-opening door)

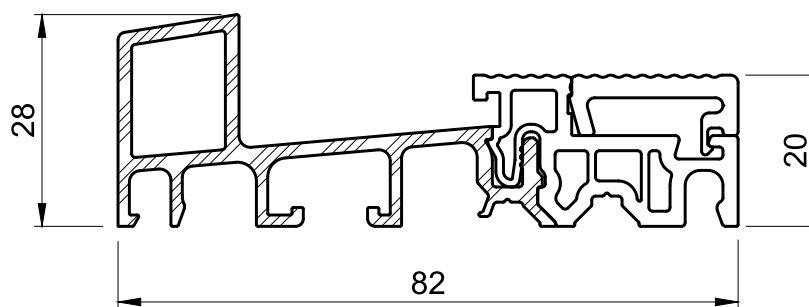

**ZS7130**  
 Door threshold

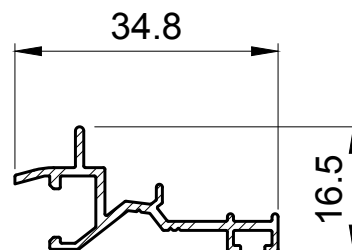

**VA7231**  
 Weather profile strip

**Accessories** (not to scale)

Gasket

**DP7230**



Threshold holder set for frames  
**ZS7520**

Adapter  
**MT7580**

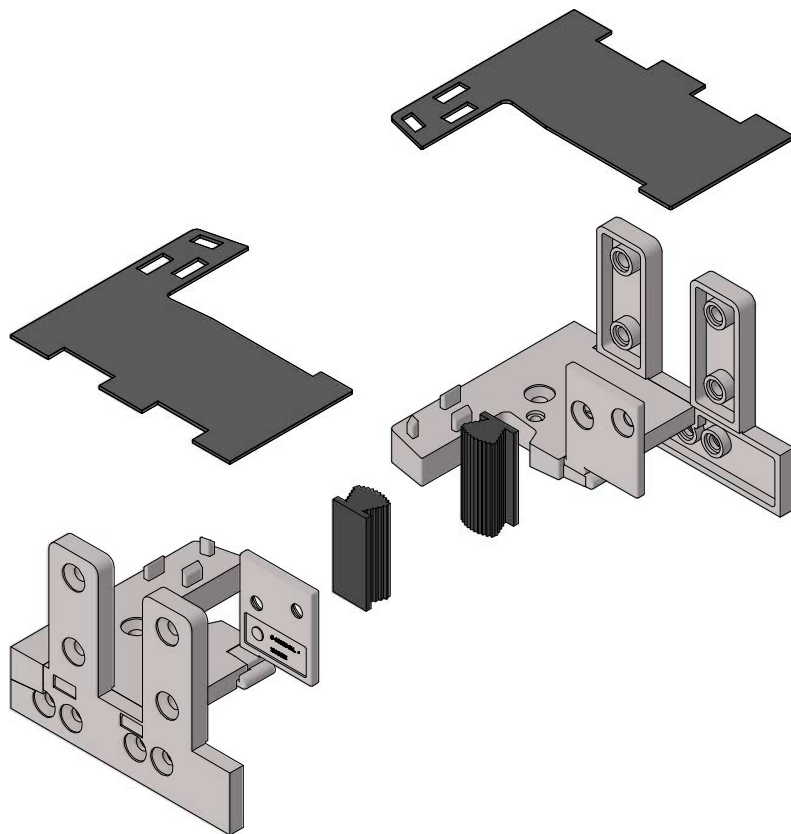

**ZS7520**

Threshold holder set

for frames HO8020, HO8021, HO9020, HO9021, HO9100,

HO9110

Drilling jig MT9940 (not depicted)

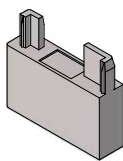

**MT7575**

Adapter

for threshold holder set ZS7520 with frame HO9110

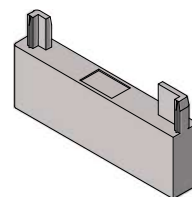

**MT7580**

Adapter

for threshold holder set ZS7520 with frame HO9100

Threshold holder set for frames

**ZS7620**

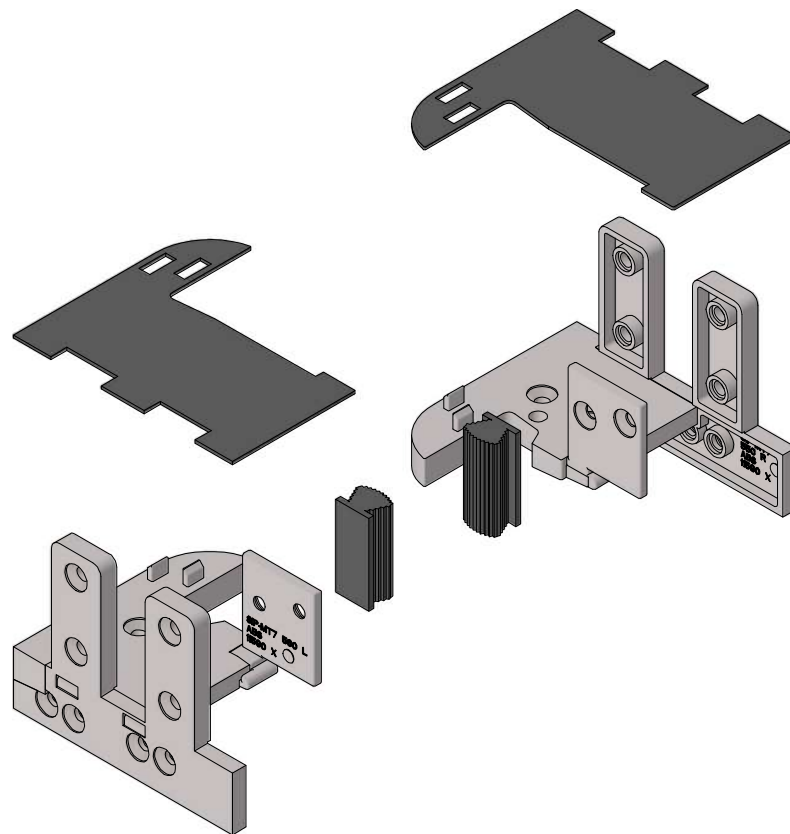

**ZS7620**

Threshold holder set  
for frame HP9220

Drilling jig MT9940 (not depicted)

Threshold holder set for frames

**ZS7530**

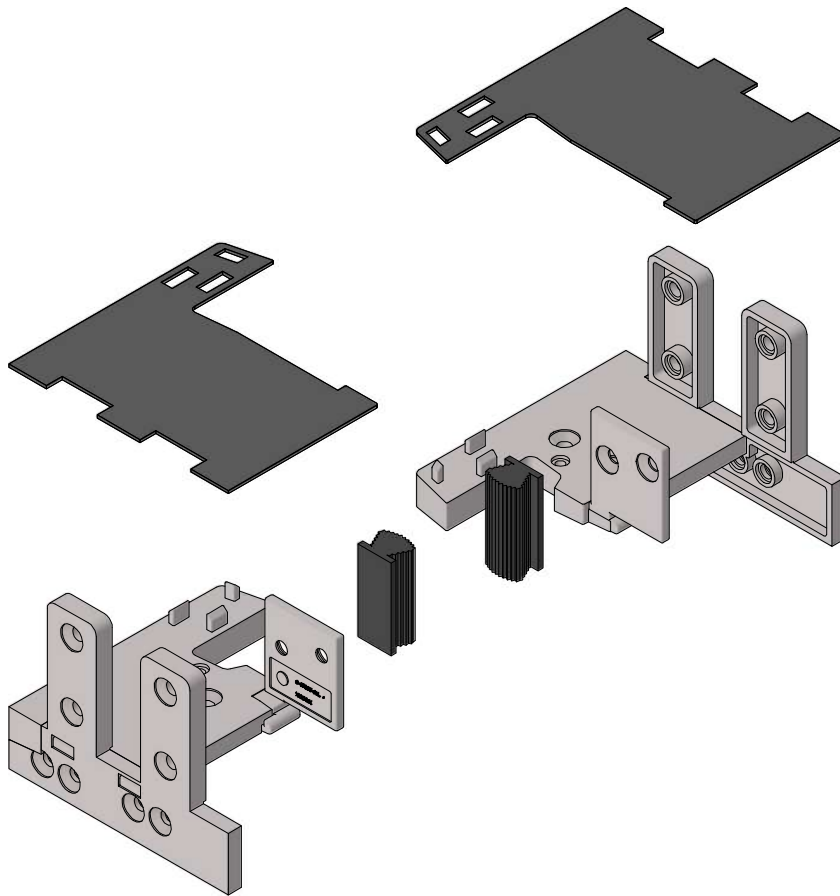

**ZS7530**

Threshold holder set  
for frames HO8030, HO9030  
Drilling jig MT9940 (not depicted)

Threshold holder set for frames

**ZS7525**

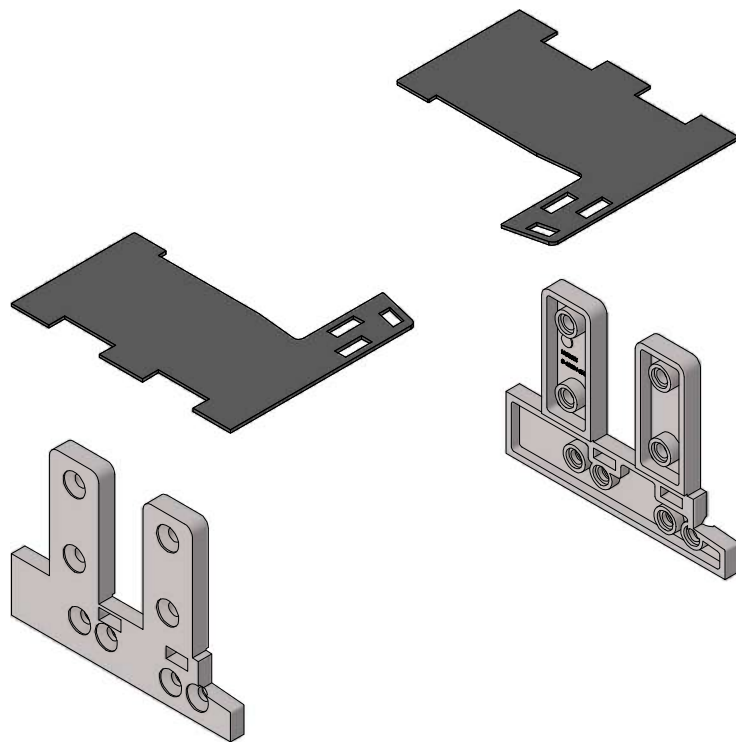

**ZS7525**

Threshold holder set

for frames HO8020, HO8021, HO9020, HO9021

Drilling jig MT7125 (not depicted)

(Outward-opening door)

Threshold holder set for frames

**ZS7535**

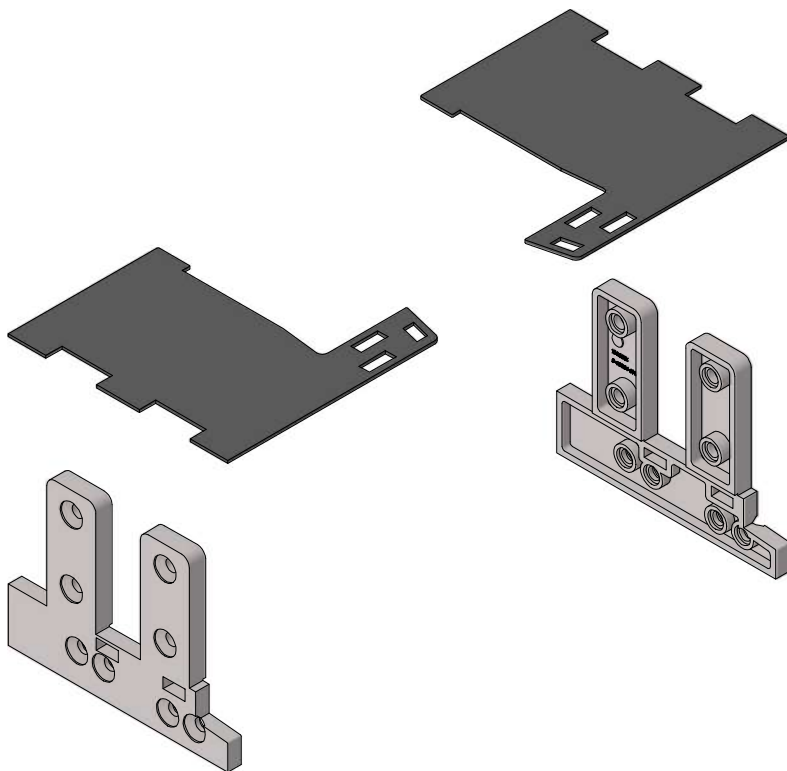

**ZS7535**

for frames HO8030, HO9030  
Drilling jig MT7125 (not depicted)  
(Outward-opening door)

Screw blocks

**MT7131, MT7132**

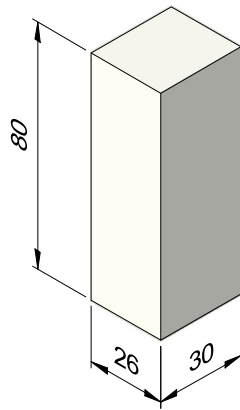

**MT7131**

Screw block

for frames HO8020, HO9020, HO9021

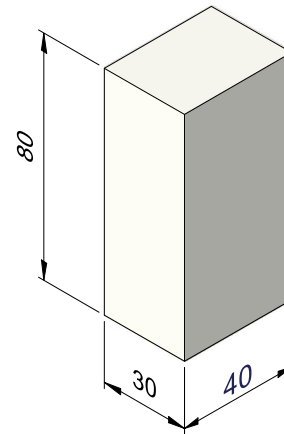

**MT7132**

Screw block

for frames HO8030, HO9030

Threshold holder set for fixed mullions

ZS7820, ZS7840

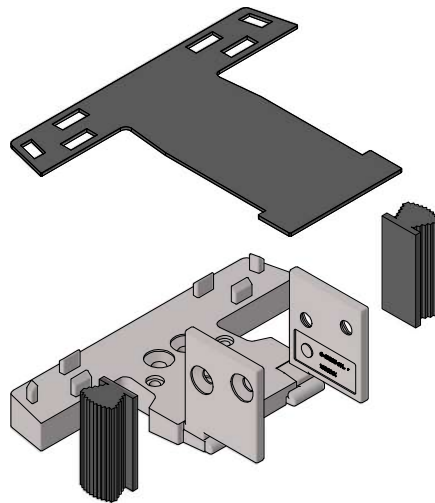

**ZS7820**

for fixed mullions HO9320, HO9310, HO8320, HO8310

Drilling jig MT9940 (not depicted)

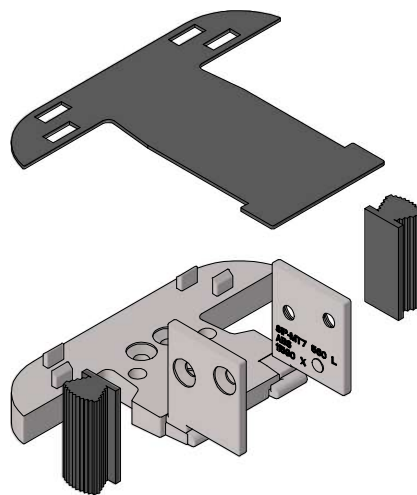

**ZS7840**

for fixed mullion HP9420

Drilling jig MT9940 (not depicted)

Threshold holder set for fixed mullions

**ZS7845**

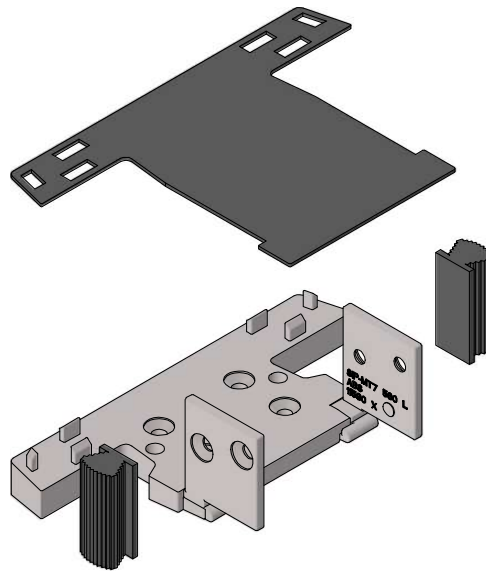

**ZS7845**

for fixed mullions HO9340, HO9330  
 Drilling jig MT9940 (not depicted)

Weather profile strip  
VA7215

Protective caps  
ES7215, ES7216, ES7217, ES7218

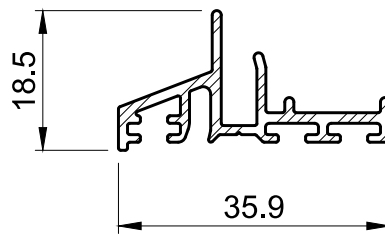

VA7215

**Accessories** (not to scale)

Brush seal  
414971



Brush seal  
DP7010

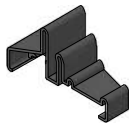

**ES7215**

Protective cap  
for weather profile strip VA7215  
Passive sash DIN left



**ES7217**

Protective cap  
for weather profile strip VA7215  
Active sash DIN right

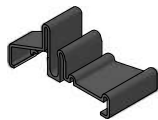

**ES7218**

Protective cap  
for weather profile strip VA7215  
Active sash DIN left

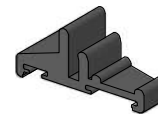

**ES7216**

Protective cap  
for weather profile strip VA7215  
Passive sash DIN right

Accessories for door thresholds

**ES2040, VA7410, MT7950, ZS7890**

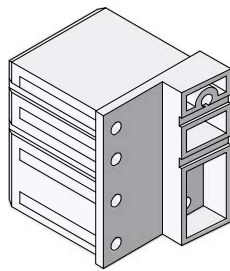

**ES2040**

Threshold holder for fixed side part

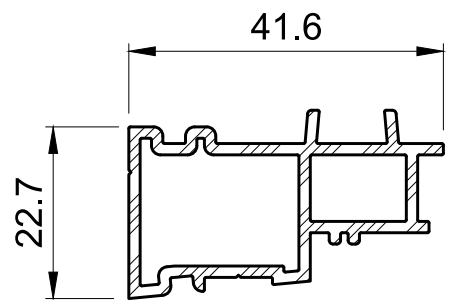

**VA7410**

Compensating piece for fixed side part

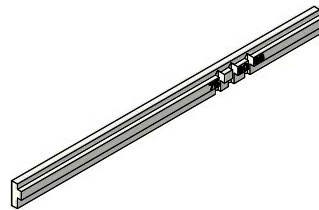

**MT7950**

Strike plate compensation piece

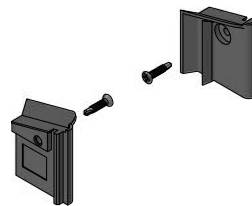

**ZS7890**

Rebate seal part set  
(Outward-opening door)

Widening

NP8200, NP8300

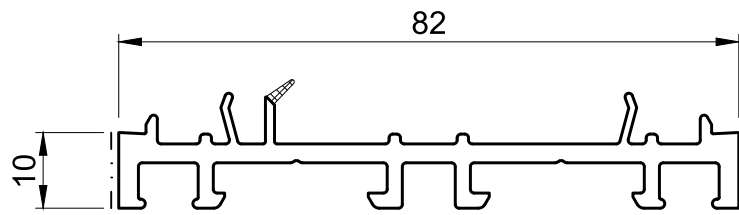

NP8200

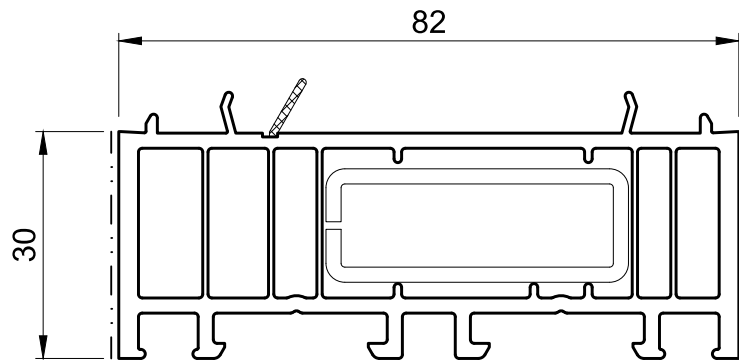

NP8300

**Accessories** (not to scale)

Strengthening

VS4020



Widening

**NP8500**

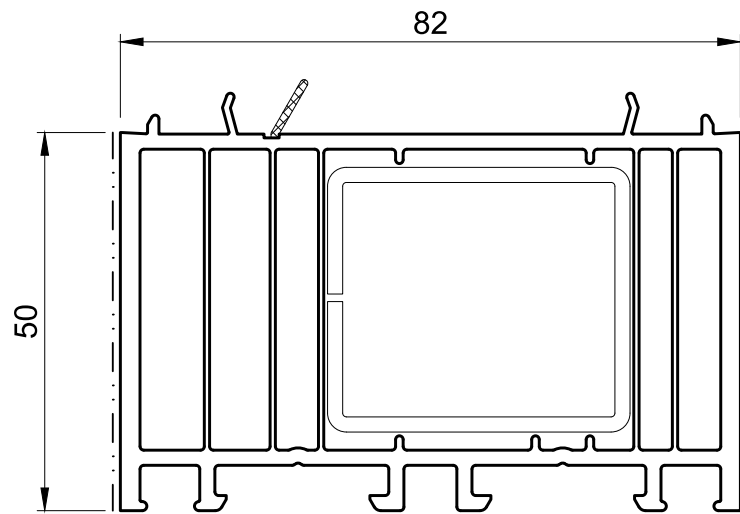

**Accessories** (not to scale)

Strengthening

VS3030

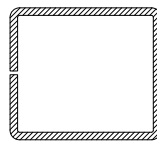

Widening

NP8700

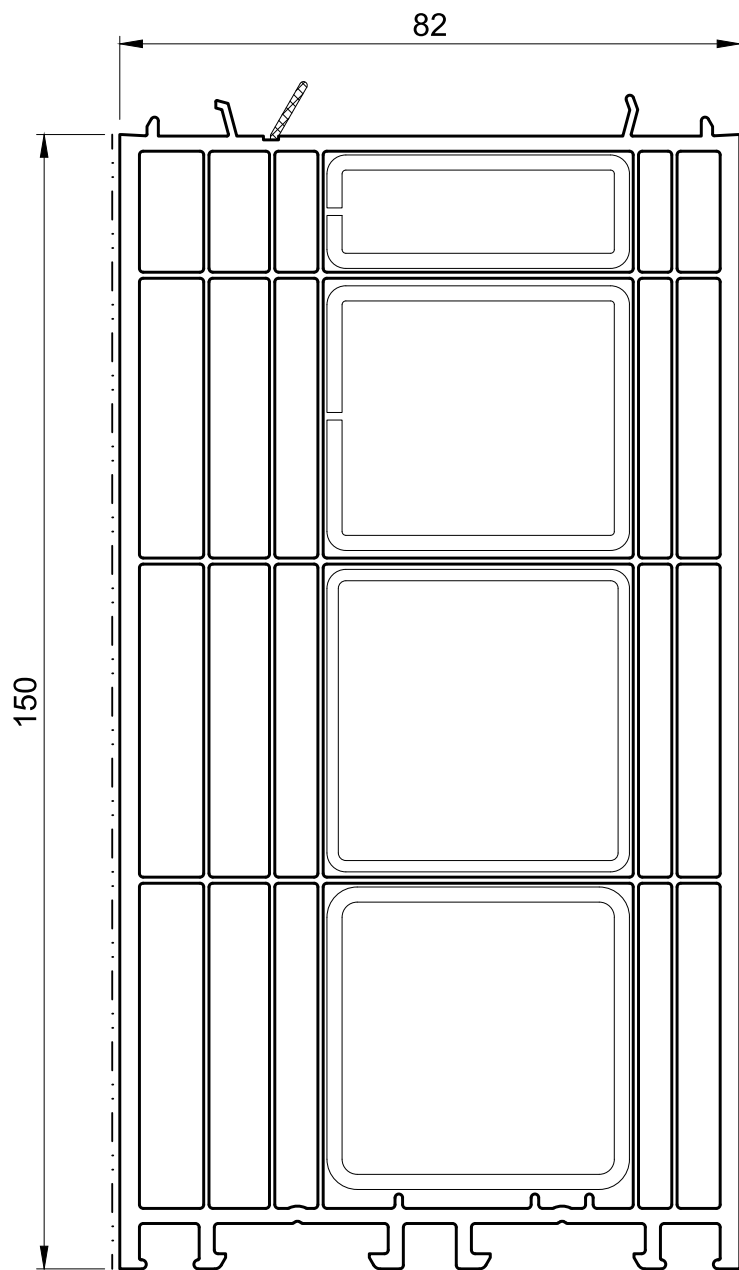

**Accessories (not to scale)**

Strengthening  
VS4020



Strengthening  
VS3030

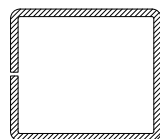

Strengthening  
715303

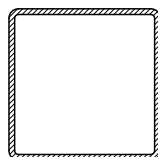

Strengthening  
415040

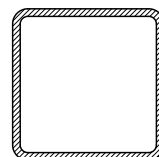

Widening

**NP3300**

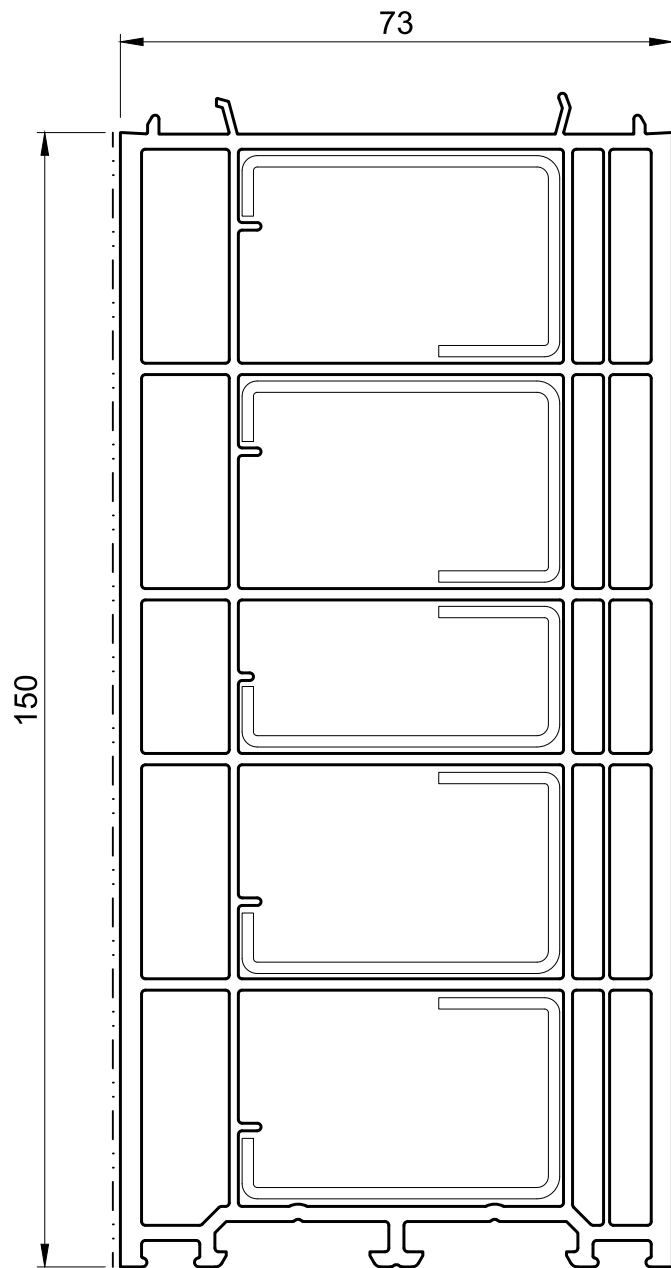

**Accessories** (not to scale)

Strengthening  
VS1010



Strengthening  
VS1020



Strengthening  
VS1120



Base profile

NP3280

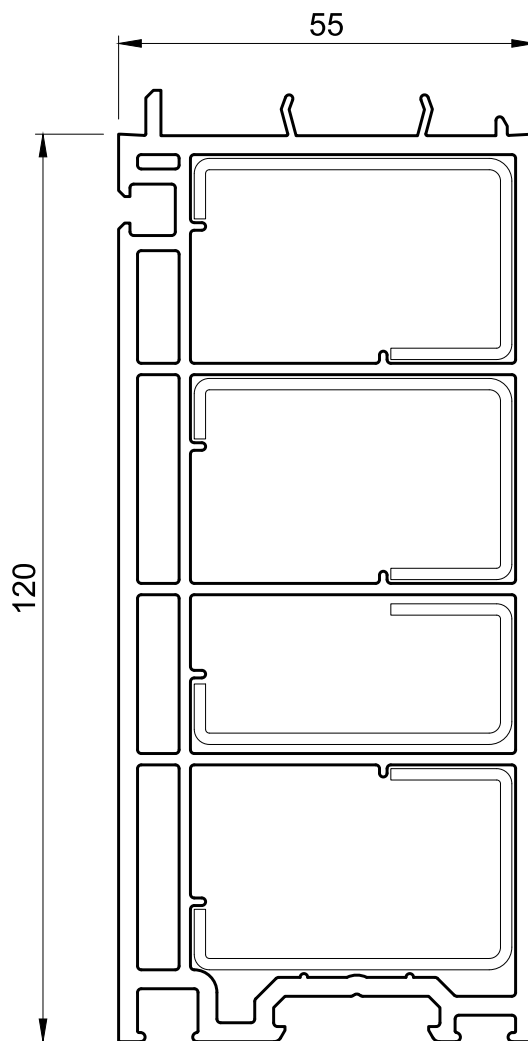

**Accessories** (not to scale)

Strengthening  
VS1010

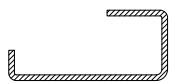

Strengthening  
VS1020



Strengthening  
VS1120



Base profile

**NP8280**

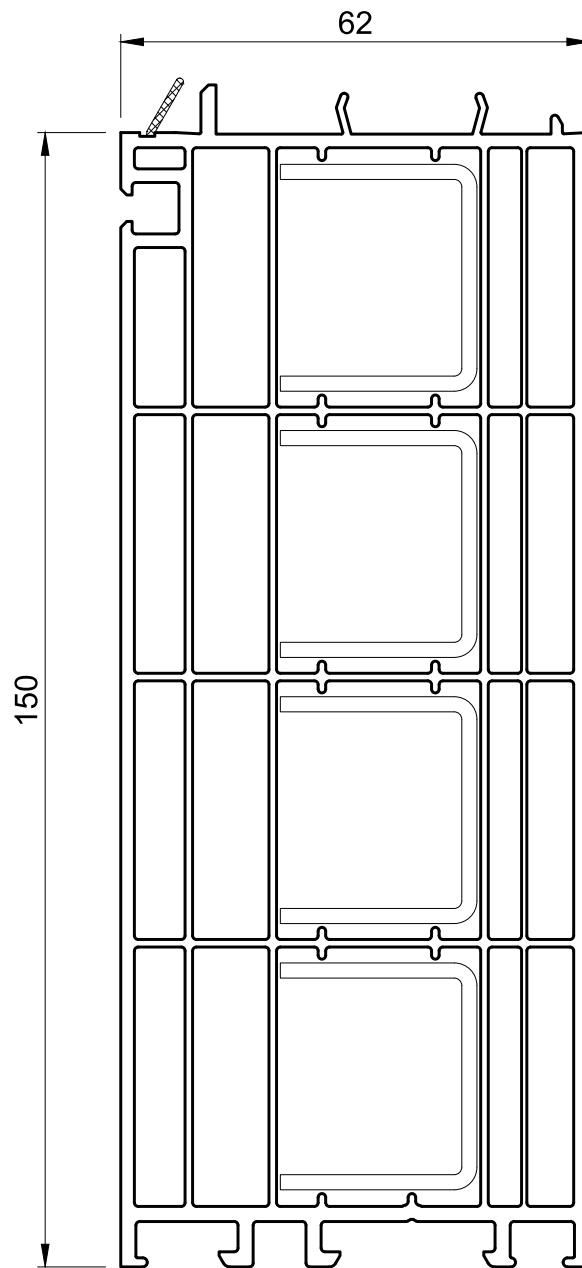

**Accessories** (not to scale)

Strengthening

VS8020

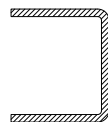

Widening

NP1120, NP1350

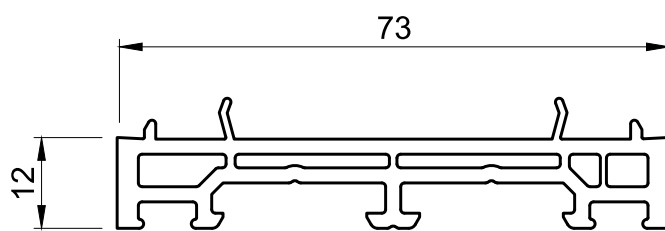

NP1120

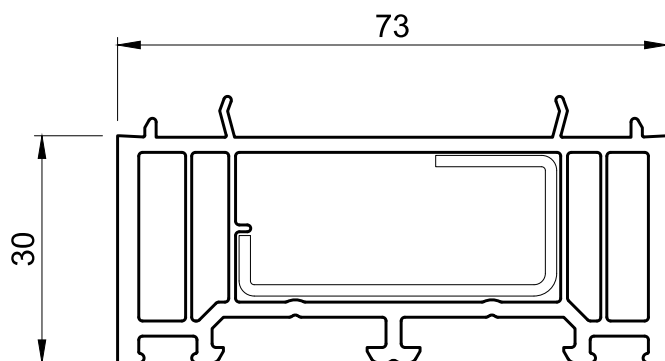

NP1350

**Accessories** (not to scale)

Strengthening

VS1010



Widening

**NP1550**

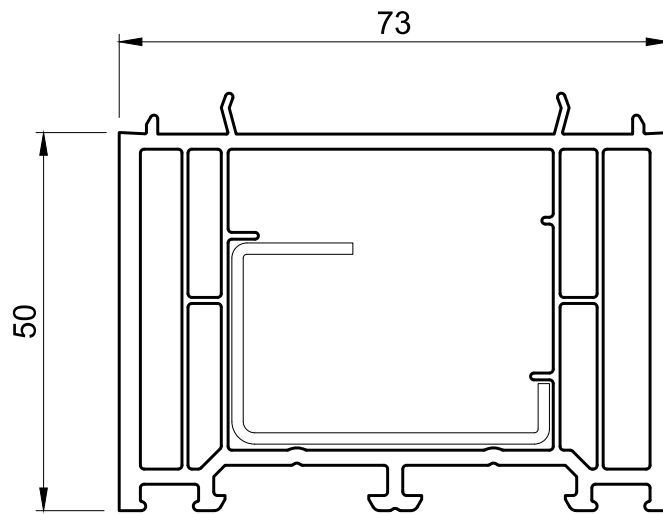

**Accessories** (not to scale)

Strengthening

Strengthening

VS1020

VS1120



External sill connections

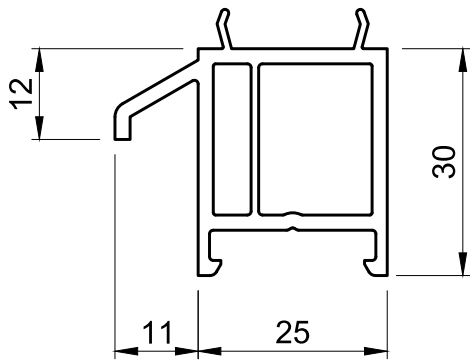

NP0300

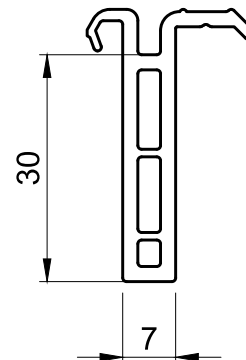

NP0320

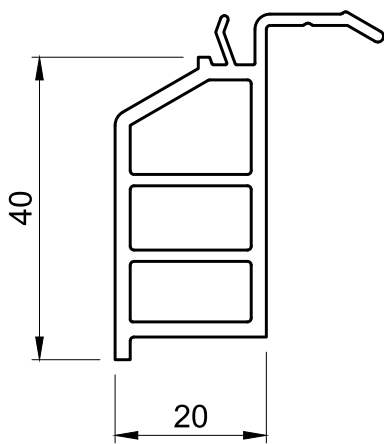

NP0360

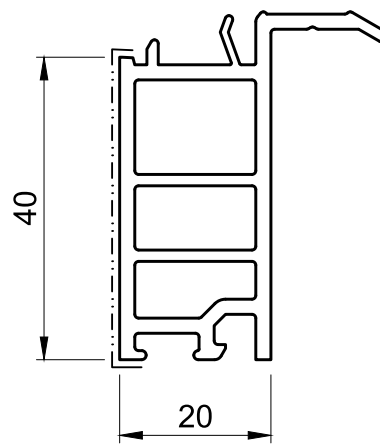

NP0370

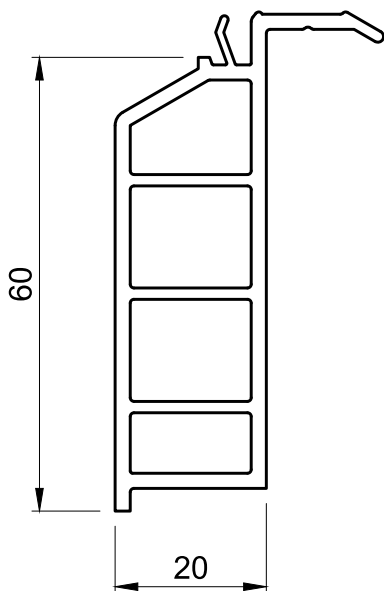

NP0380

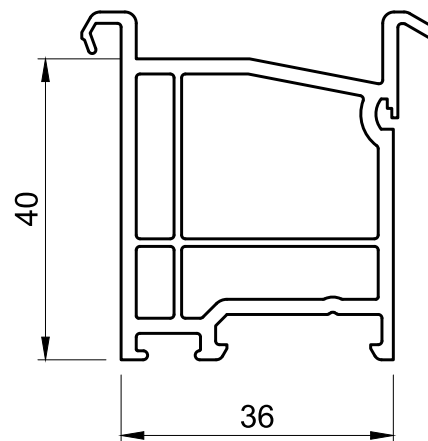

NP0400

External sill connections

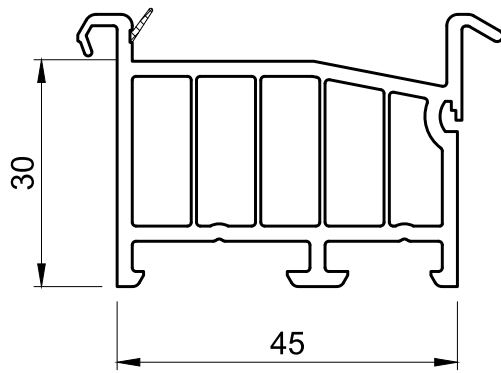

**NP8020**

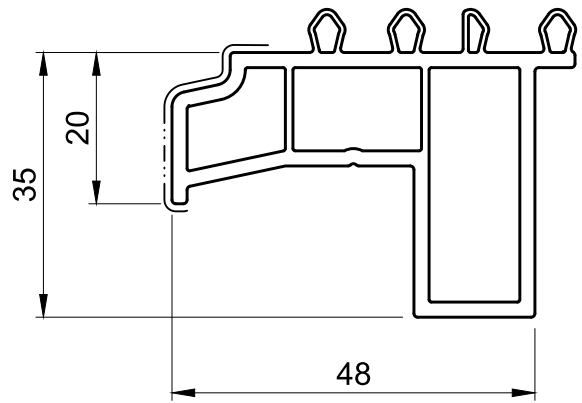

**416119**

Window sill connections

NP0770, NP0960

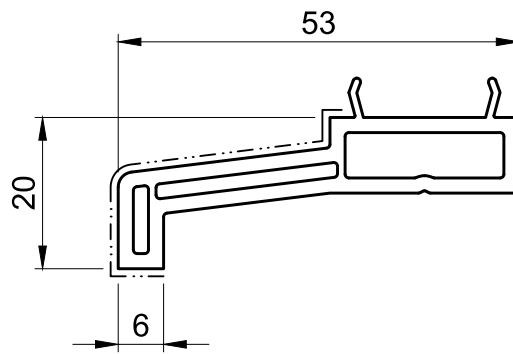

NP0770

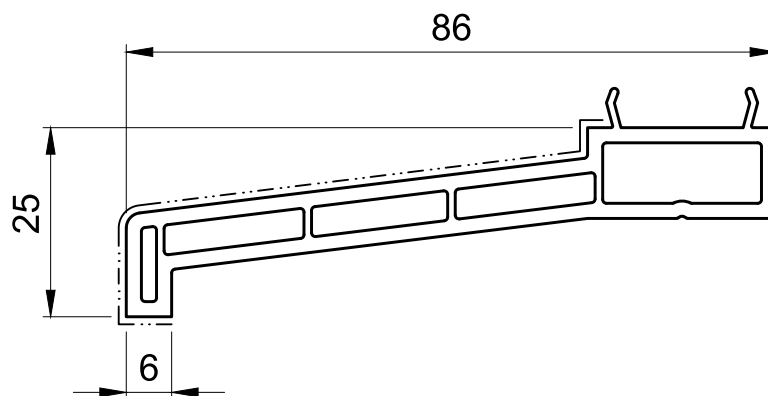

NP0960

**Accessories** (not to scale)

End caps

ES0960

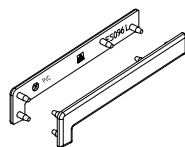

Window sill connection

**NP0850**

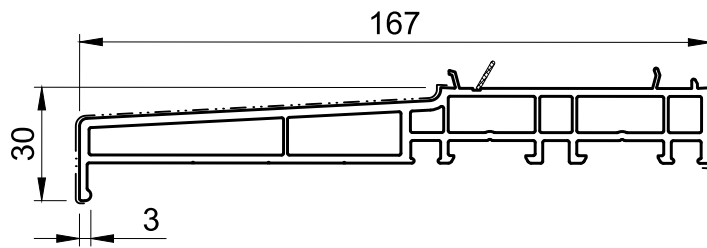

**Accessories** (not to scale)

End caps

417115

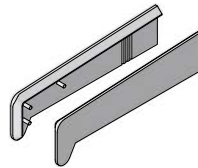

Coupling profiles

NP0190, NP8110, NP8120, NP8170

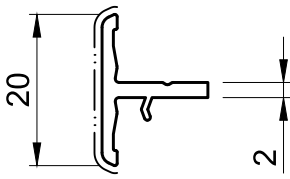

NP0190

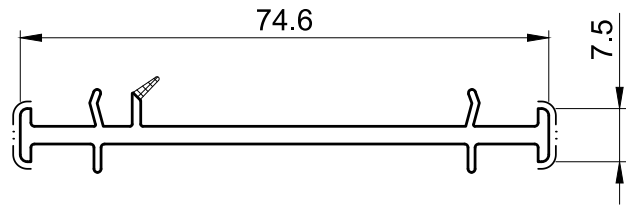

NP8110

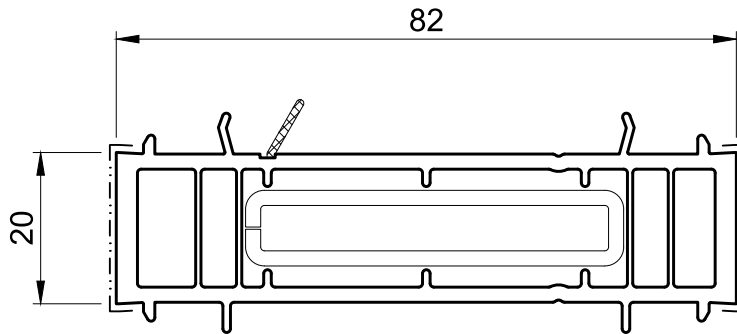

NP8120

Accessories (not to scale)

Strengthening

405015

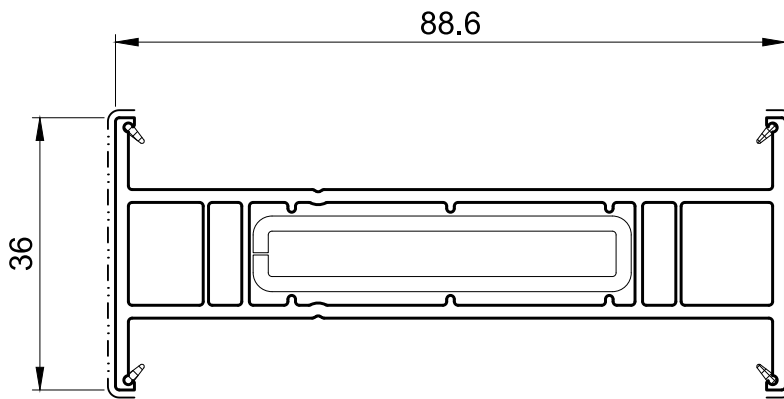

NP8170

Accessories (not to scale)

Strengthening

405015

Strengthening

405125



Coupling profiles  
**VS8140, NP8140**

Cover profile  
**ZF2110**

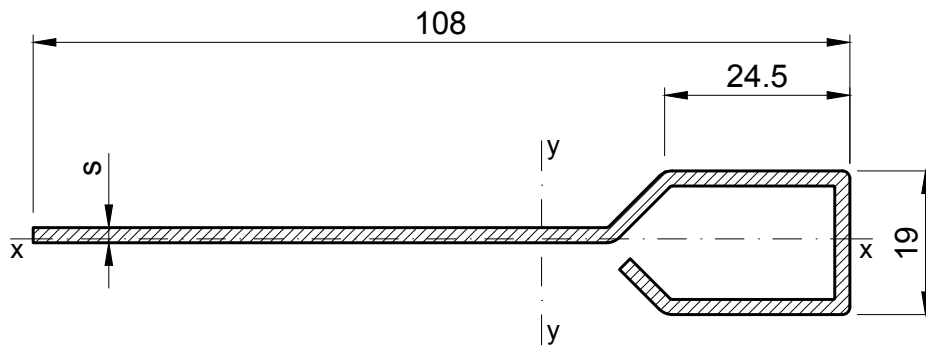

**VS8140**

Key number	Thickness s (mm)	Ix (cm <sup>4</sup> )	Iy (cm <sup>4</sup> )	Weight (g/m)
74	2.0	0.88	34.10	Approx. 2478
Application	NP8140, ZF2110			

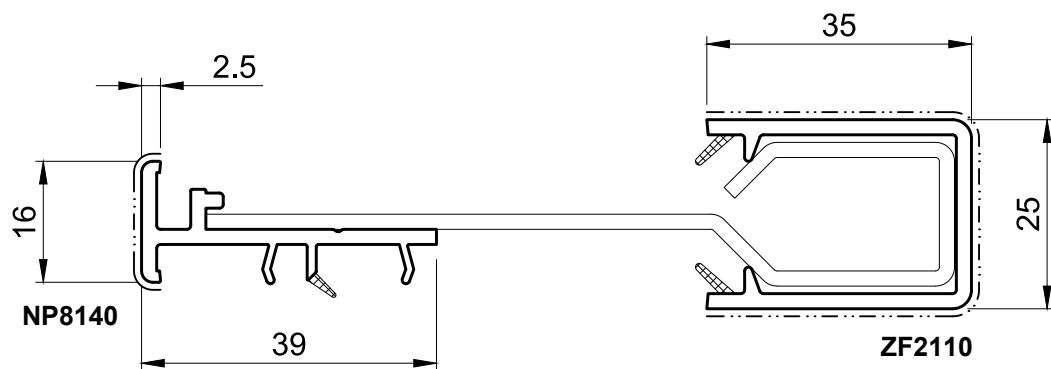

**Accessories (not to scale)**

Spacer  
 MT8140



Corner connector, 90°

NP0100

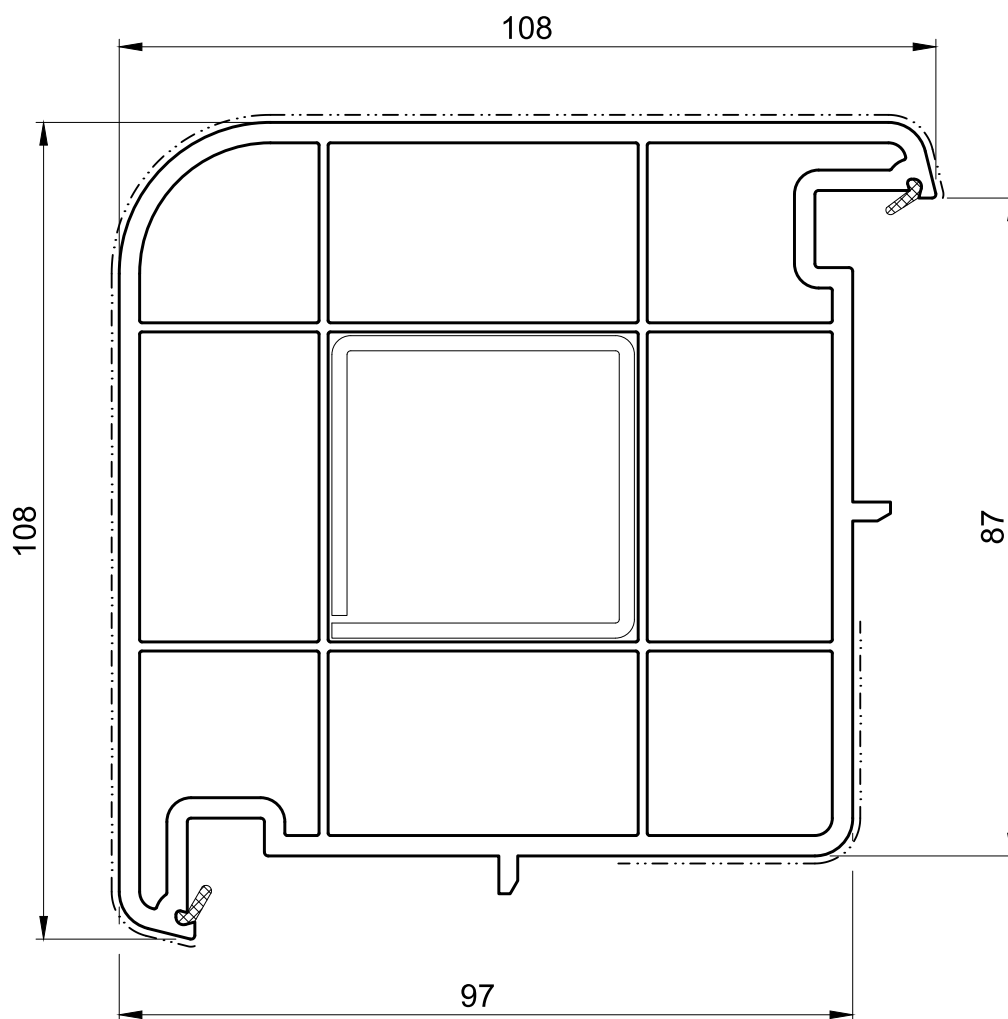

**Accessories (not to scale)**

Strengthening  
405060

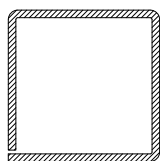

End cap  
417210

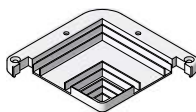

Insulation strip  
417810

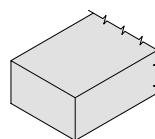

Corner connection, 135°

416240

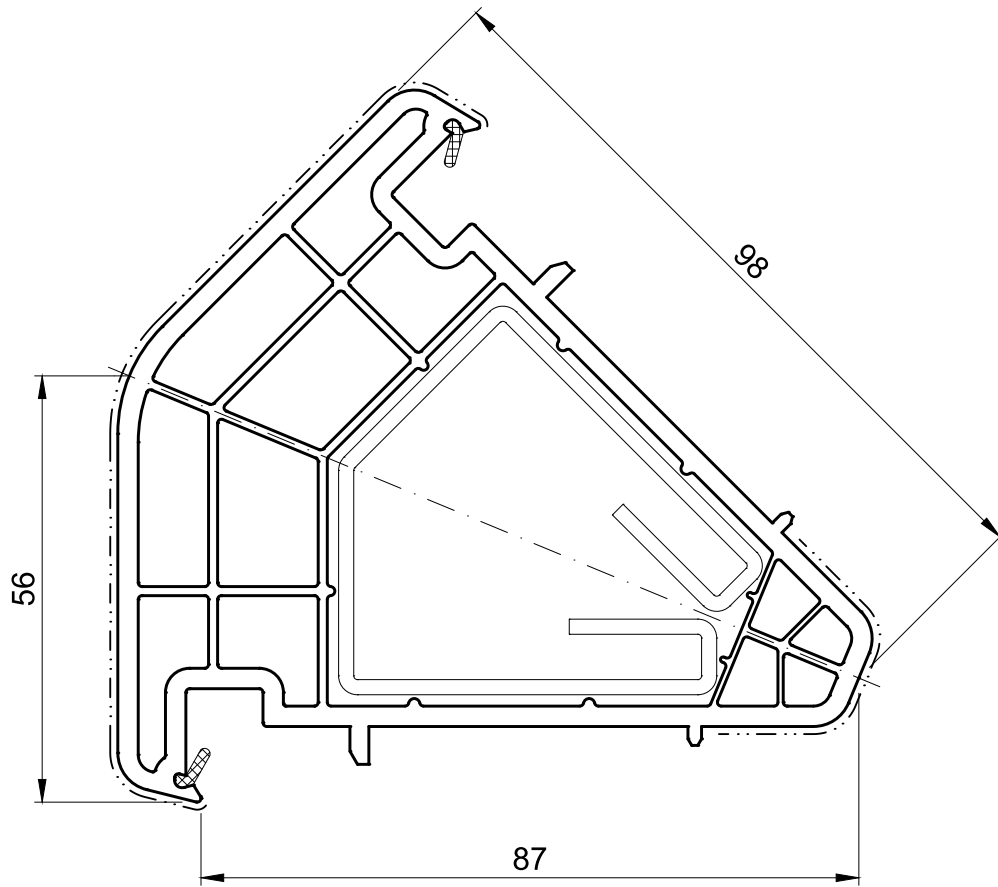

**Accessories (not to scale)**

Strengthening  
415140

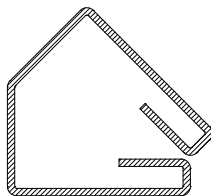

End cap  
417240

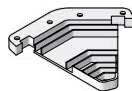

Fixed iron  
407570



Fixed iron  
407571



Corner connector, variable

NP8160, NP8150

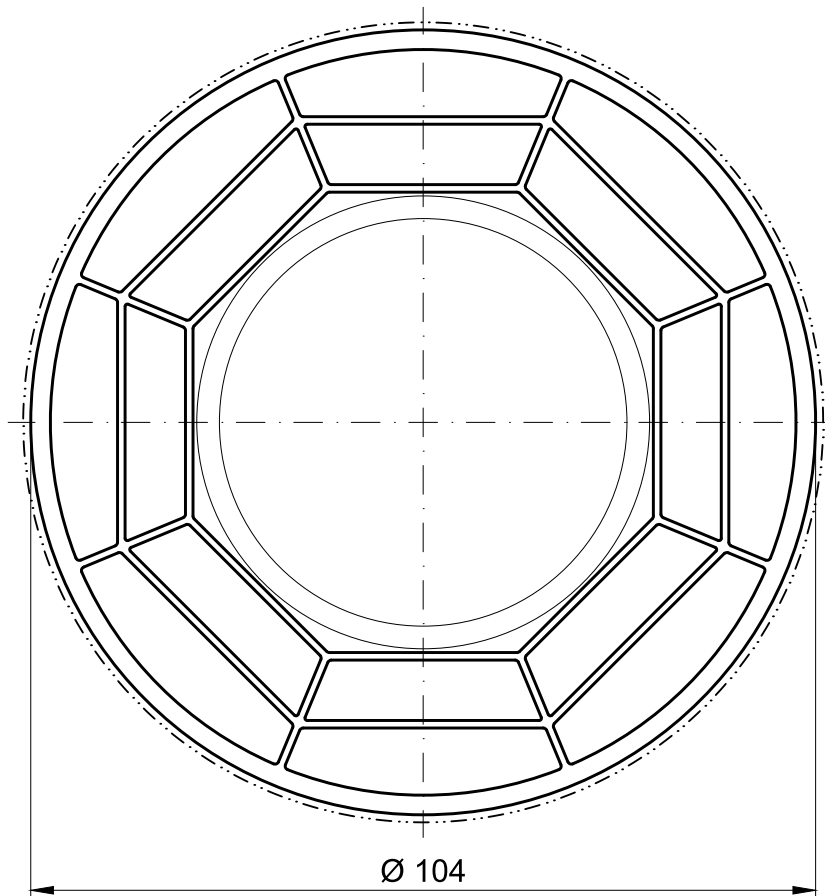

NP8160

**Accessories** (not to scale)

Strengthening

VS8160

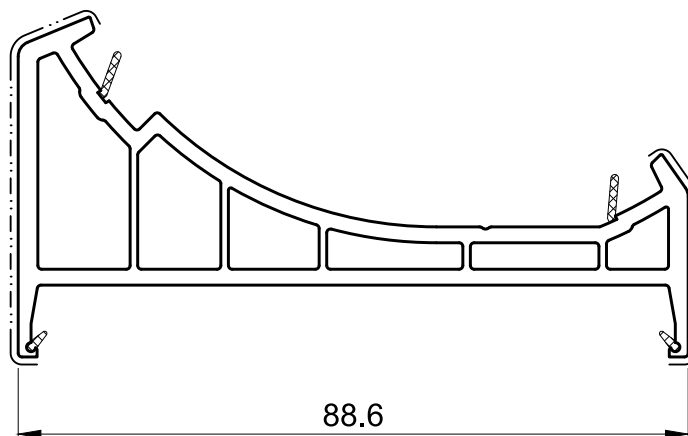
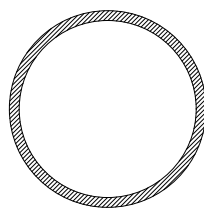

NP8150

Doorframe

**406271**

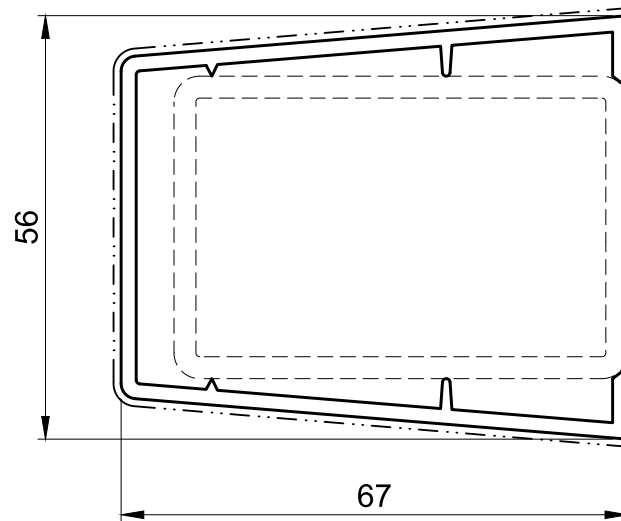

**Accessories** (not to scale)

Strengthening

Steel, galvanised

60 x 40 x ... mm.

Thickness according to static specifications.

Purchase through steel trade.

Architrave

416269

Cover profile

416311

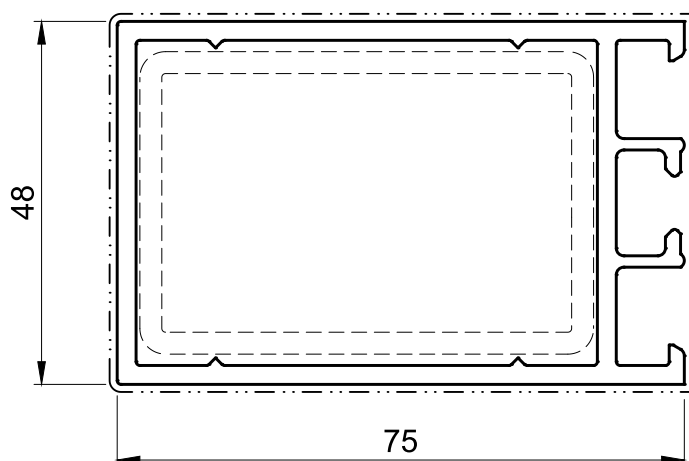

416269

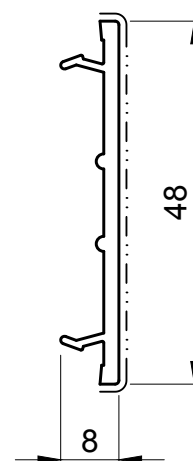

416311

**Accessories** (not to scale)

Reinforcing profile      Snap-in head screw

Steel, galvanised      407900

60 x 40 x ... mm.

Thickness according  
to static specifica-  
tions.Purchase through  
steel trade.

Wall anchor

**MT1000, MT1010, MT1040**

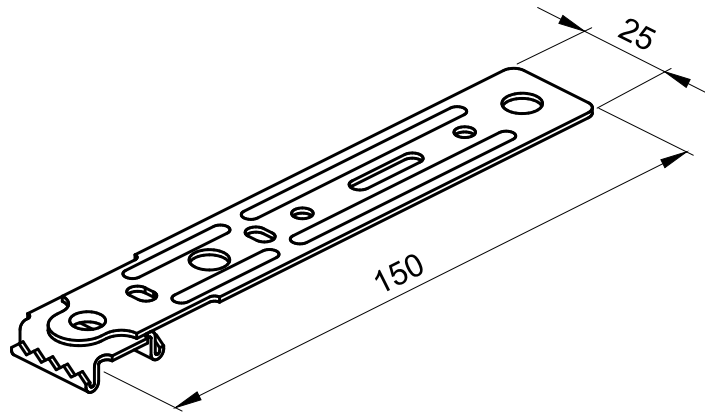

**MT1000**

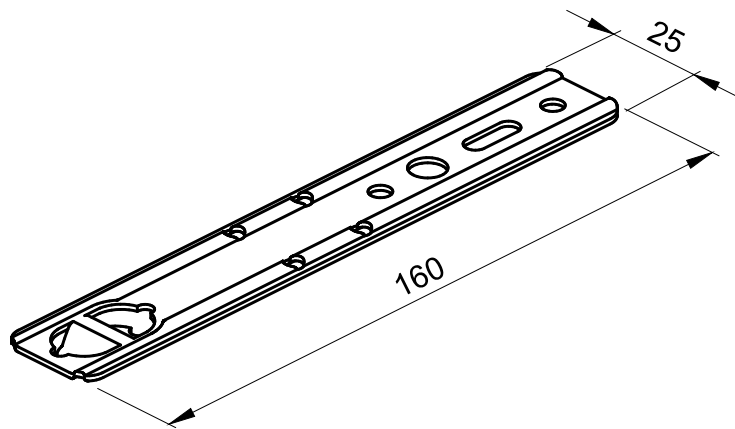

**MT1010**

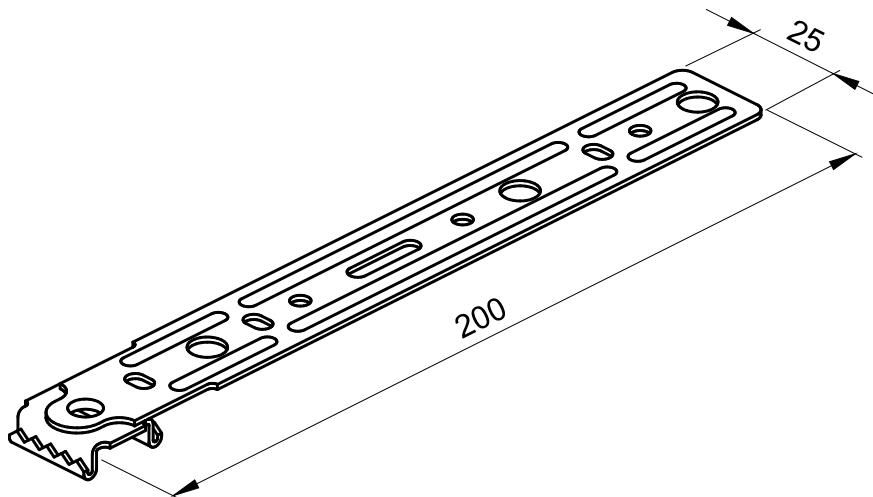

**MT1040**

Fixed iron  
407570, 407571

Rebate corner bracket  
438566

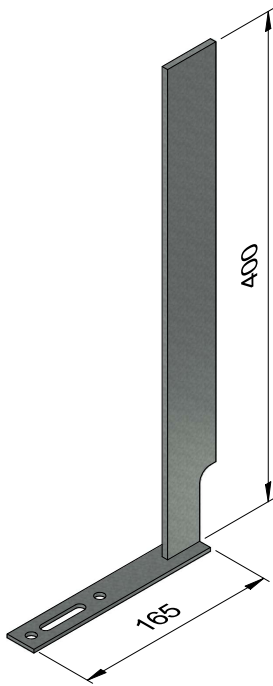

407570

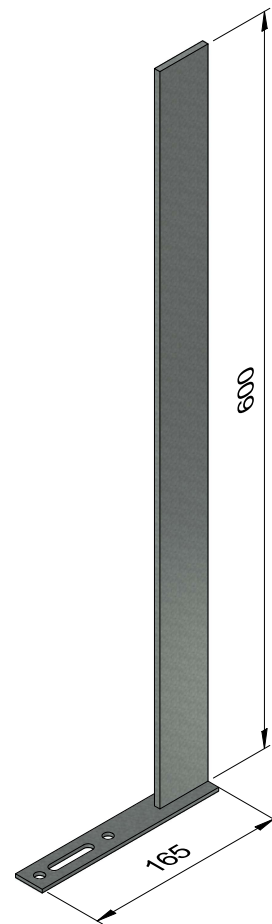

407571

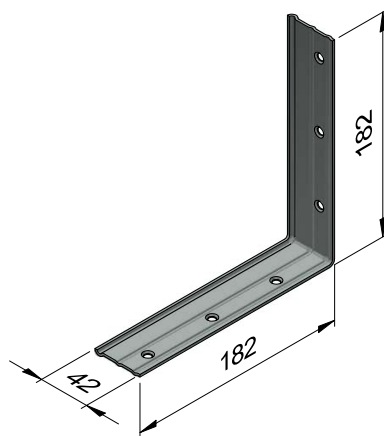

438566

Mullions, self-adhesive

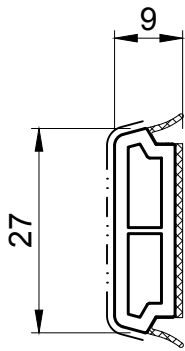

**416302**

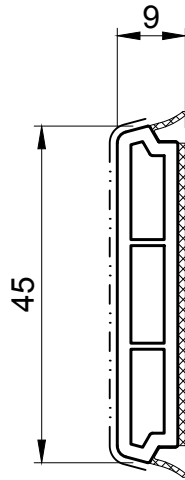

**416304**

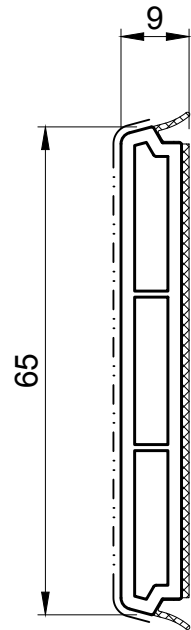

**416306**

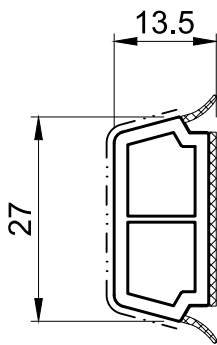

**416322**

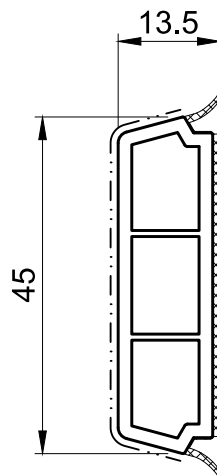

**416324**

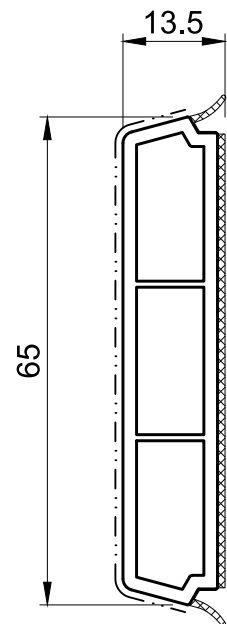

**416326**

Weather profile strip

NP0220, ZF1940

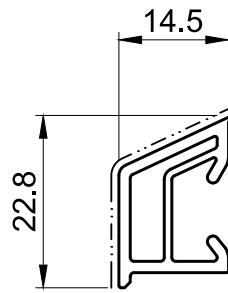

**NP0220**

**Accessories (not to scale)**

End caps

ES0220

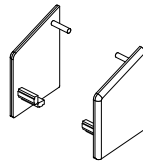

Snap-in head screw

MZ1200

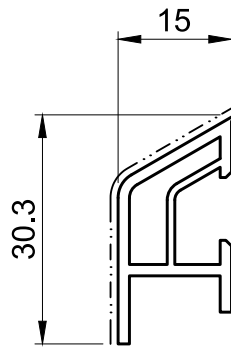

**ZF1940**

**Accessories (not to scale)**

End caps

SG1940

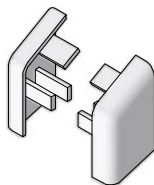

Clamping strip

NP1940



Snap-in head screw

407900



Tapee  
**416386**

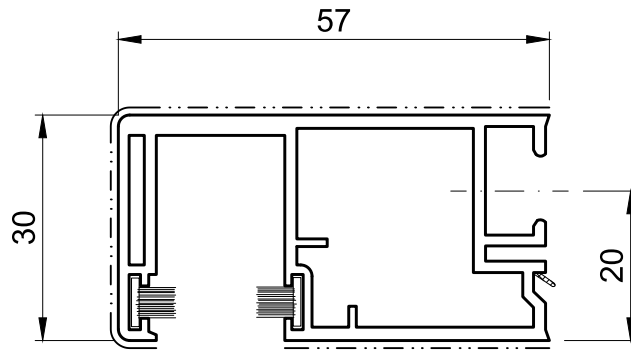

**Accessories** (not to scale)

Snap-in head screw

407965



Panel profile  
406670

Filling panel  
416274

Cover strip  
416360

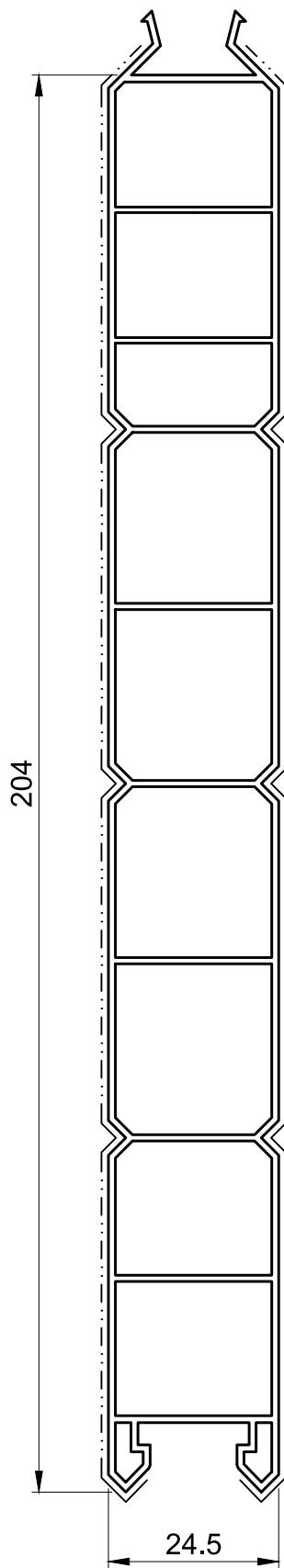

406670

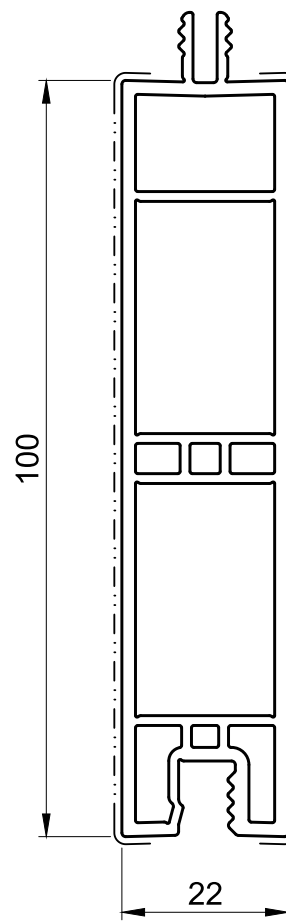

416274

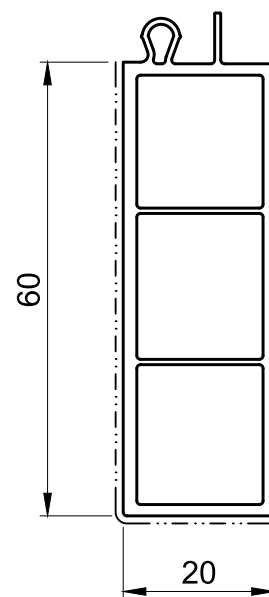

416360

Cover profile

**416327, 416337, 416357**

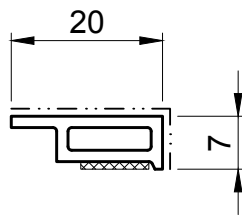

**416327\*\***

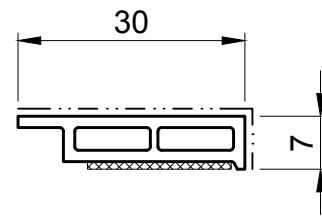

**416337\*\***

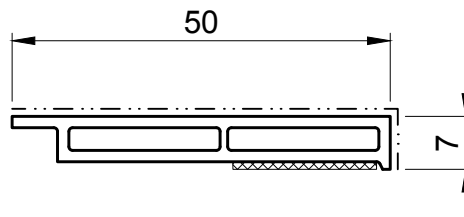

**416357\*\***

**i** INFO

\*\* In décor, use on room side only.

Cover profile  
NP8180

Cover for widenings  
NP8270

Adapter profile  
416382

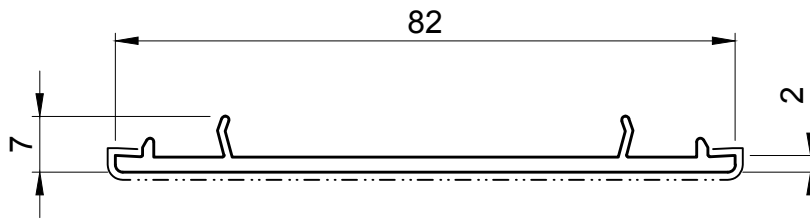

NP8180

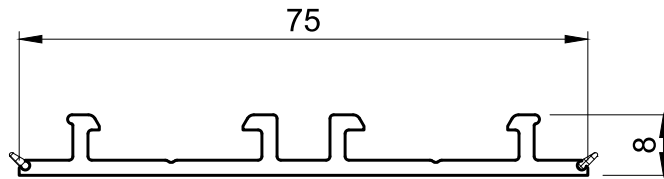

NP8270

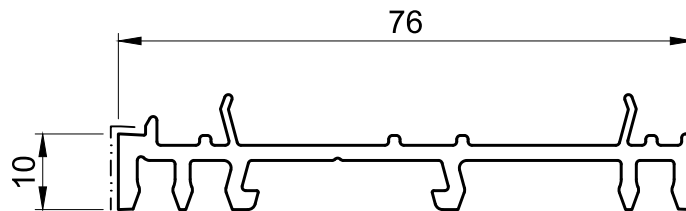

416382

Cover  
**406340**

Cover profile  
**ZF1910**

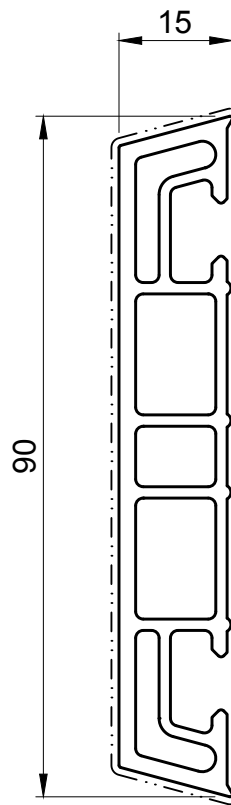

**406340**

**Accessories** (not to scale)

Snap-in head screw	Clamp-strip PVC	Clamp-strip aluminium
407900	406335	406635

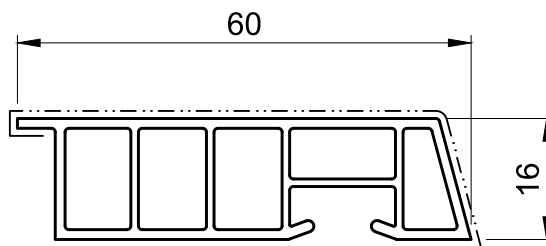

**ZF1910**

**Accessories** (not to scale)

Snap-in head screw  
MZ1200



Inner strike plate

**NP8250**

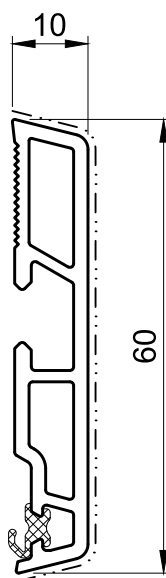

**Accessories** (not to scale)

End caps

Snap-in head screw

Clamp-strip PVC

Clamp-strip aluminium

ES8250

407900

406335

406635



Corner-bracket  
406319, 406320, 416330

Flat profile  
ZF0510

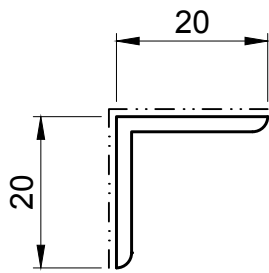

406319

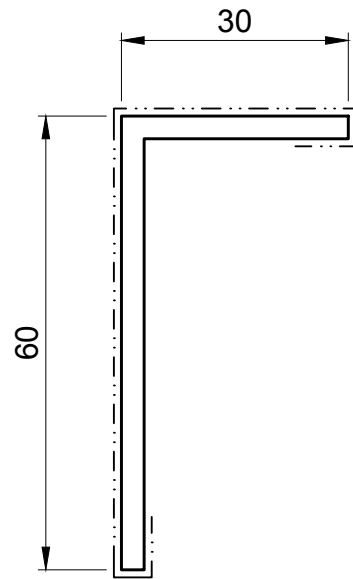

406320

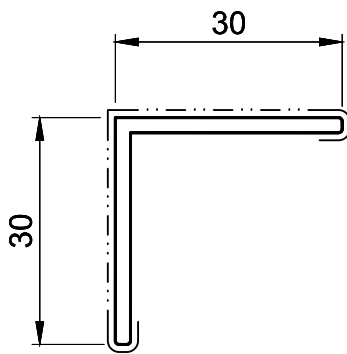

416330

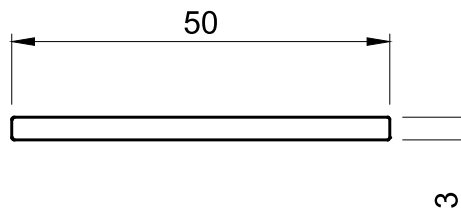

ZF0510

Roller shutter drain  
**RF3200, RF3220**

Roller shutter floor connection  
**RF3210**

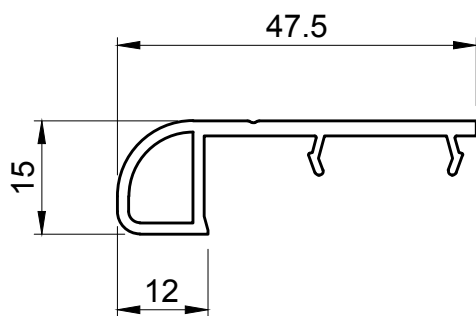

**RF3200**

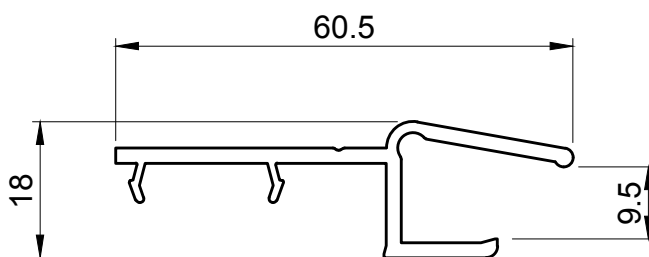

**RF3210**

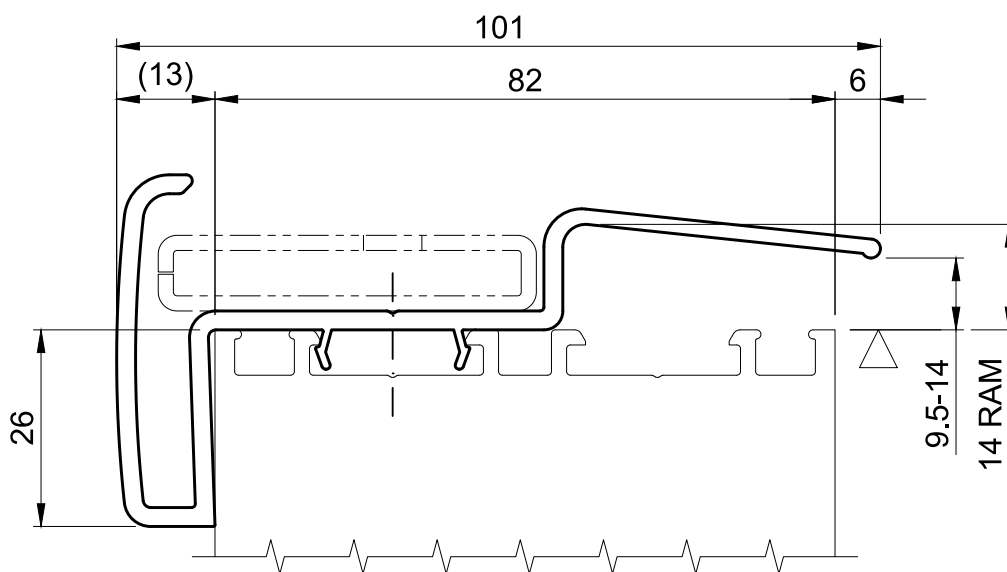

**RF3220**

**Accessories (not to scale)**

Strengthening

405015

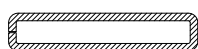

Strengthening

Steel set-square, gal-  
 vanised

50 x 30 x 5.0 mm.

Purchase through  
 steel trade.

Roller shutter guide

**RF0530**

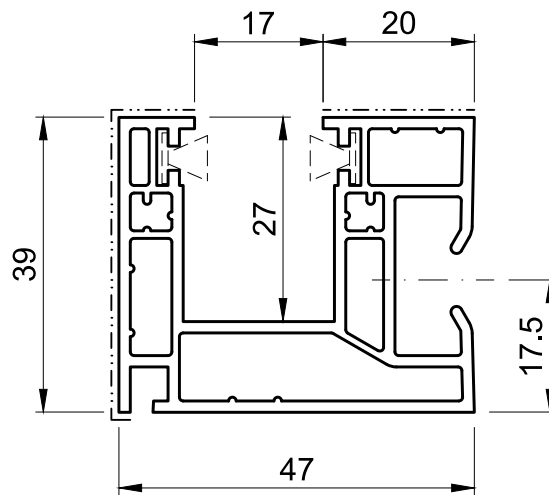

**Accessories (not to scale)**

Inlet funnel

RZ1420

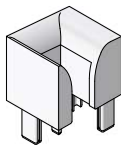

End cap

ES0530

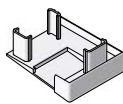

Snap-in head screw

MZ1200



Brush seal

Available from specialist dealers.

Roller shutter guide  
556070

Roll-off profile  
556075

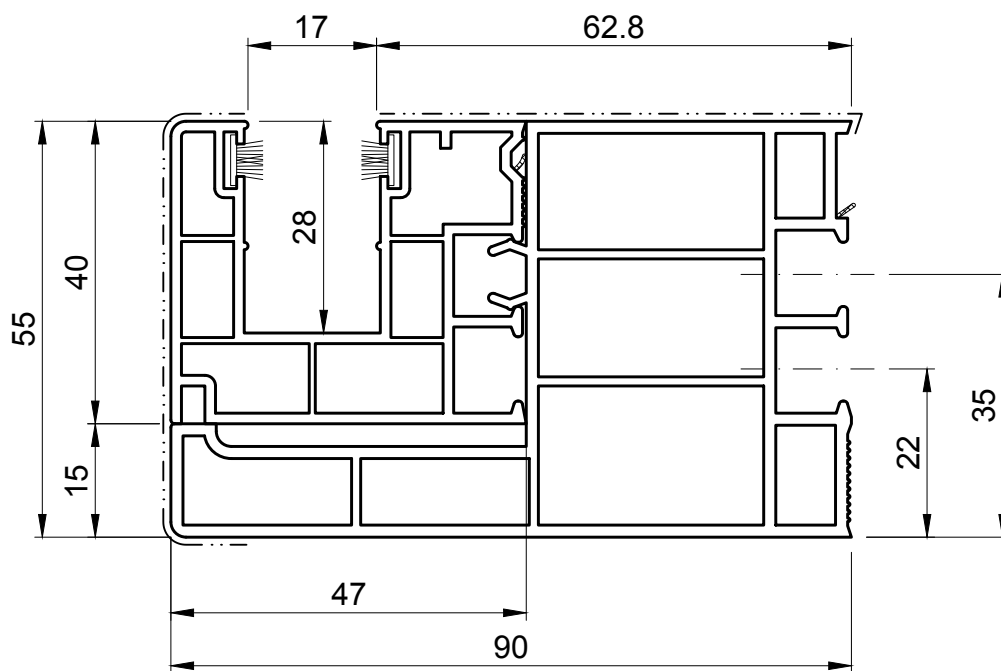

556070

**Accessories** (not to scale)

Inlet funnel  
557170

Snap-in head screw  
407965

Brush seal  
404930

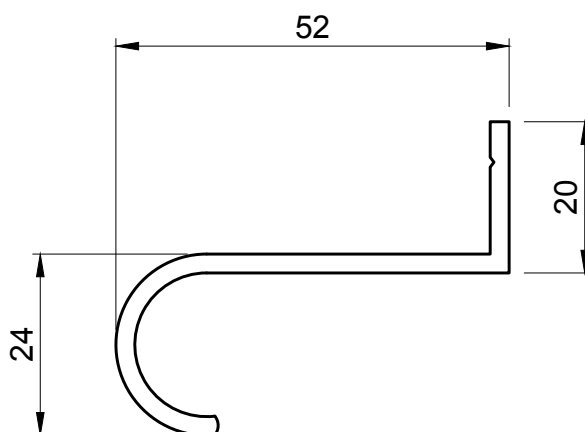

556075

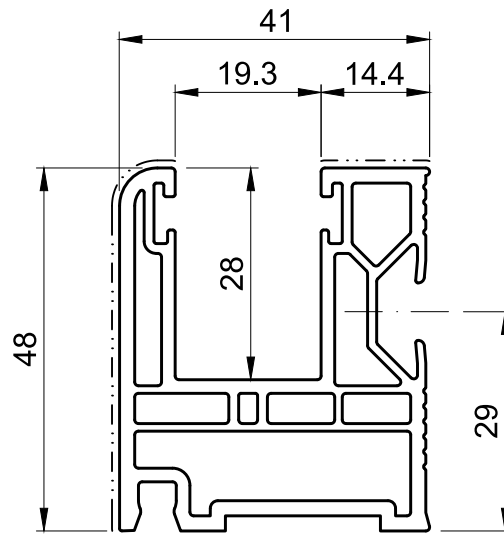

**Accessories** (not to scale)

Inlet funnel  
417082

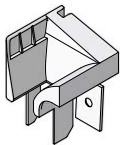

End cap  
417081

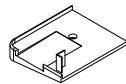

Snap-in head screw  
407900



Clamp-strip  
NP1940



Brush seal  
404935



Roller shutter guide

416096

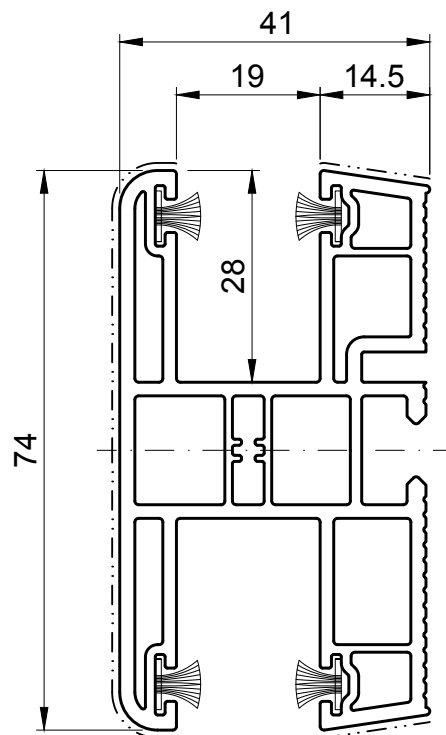

**Accessories (not to scale)**

Inlet funnel

417096

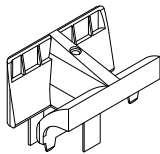

End cap

417095

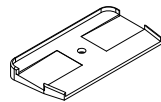

Snap-in head screw

407900



Clamp-strip PVC

406335



Clamp-strip aluminium

406635



Brush seal

404935



Laminate board  
**407914**

Sandwich panel  
**407920**

PVC panel  
**PM1320**

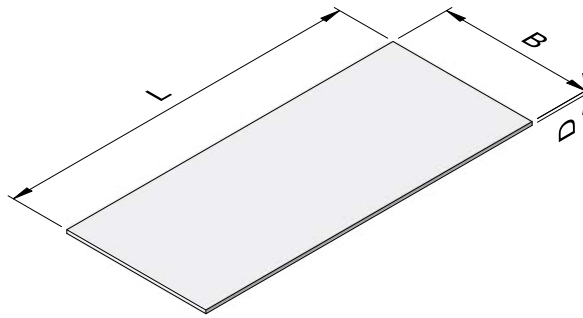

**407914**

Pattern, L x W: 3050 x 1300 mm

D = 3 mm

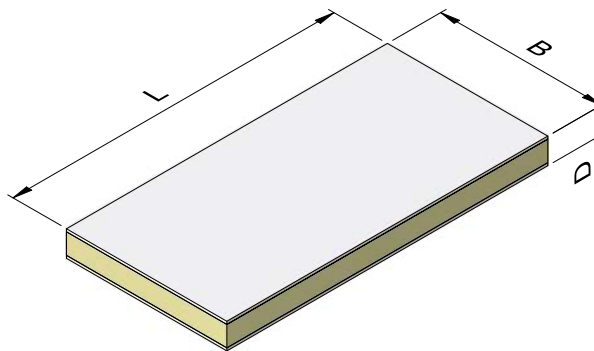

**407920**

White, L x W: 3000 x 1500 mm

Pattern, L x W: 3050 x 1300 mm

D = 24 mm

U- value: 1.348

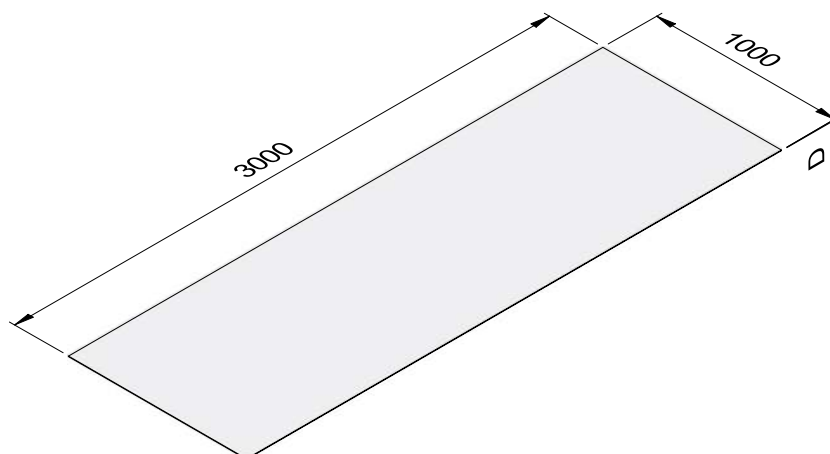

**PM1350**

Hard PVC panel, white

D = 3 mm

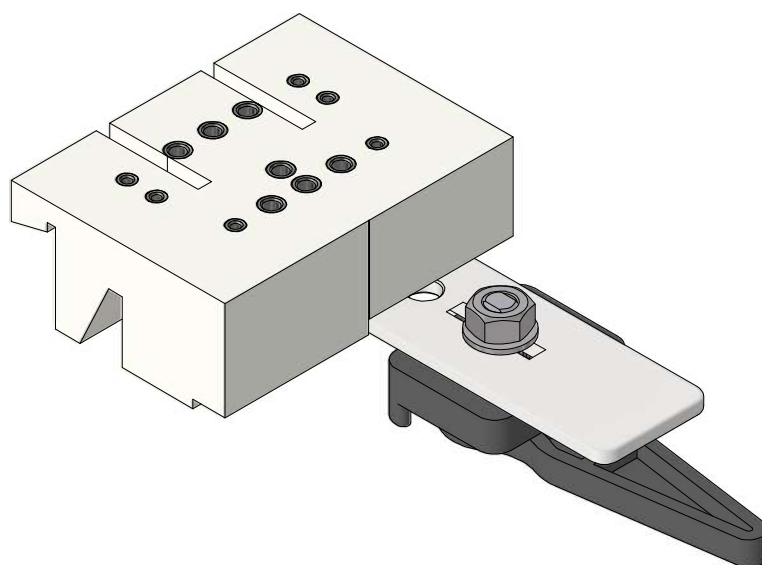

**MT9900**

Drilling and cutting jig

for fixed-mullion connector sets ZS8320, ZS8323, ZS8420, ZS9320, ZS9420

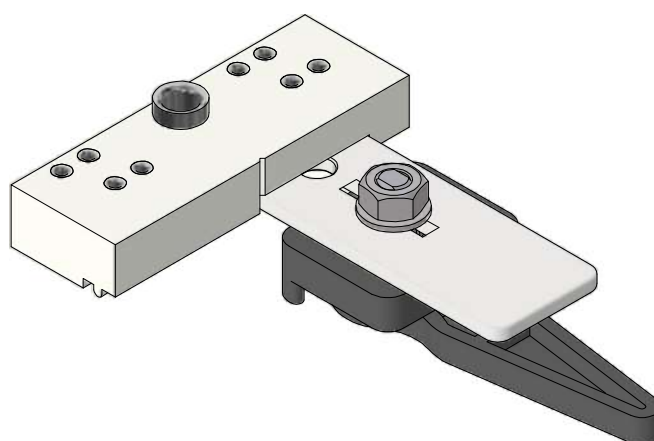

**MT9901**

Drilling and cutting jig

for fixed-mullion connector sets ZS9321, ZS9341

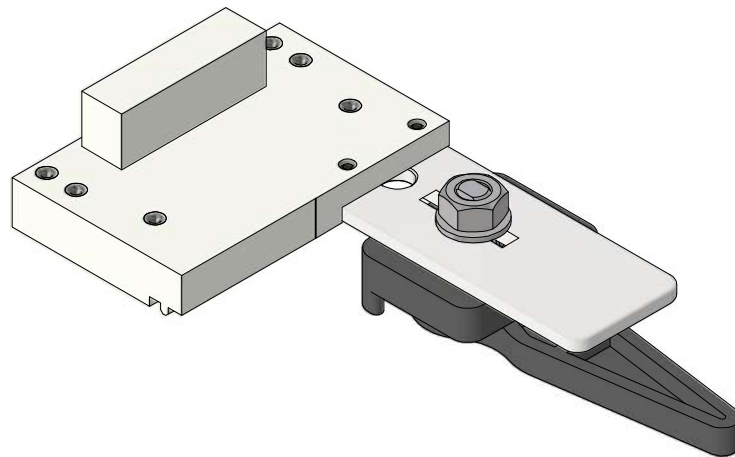

**MT9902**

Drilling jig

for fixed-mullion connector set ZS8340, ZS8343

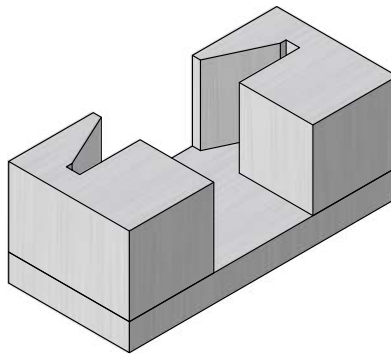

**MT9910**

Cutting jig

for fixed mullions HO9310, HO9320

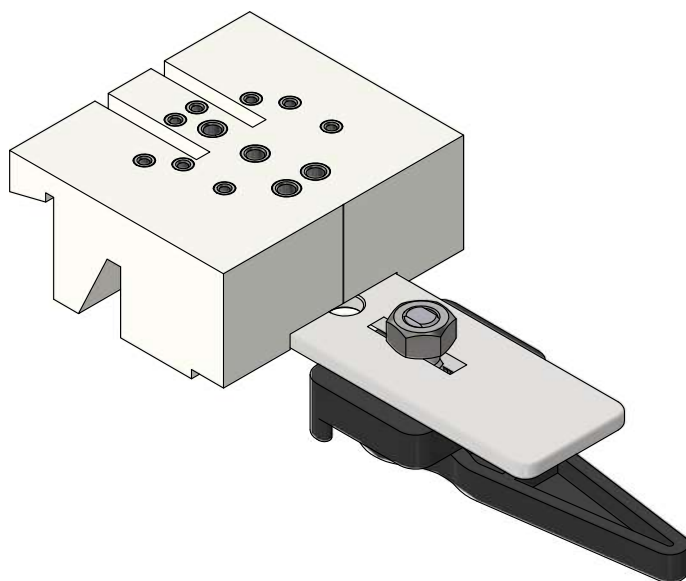

**MT9920**

Drilling and cutting jig

for glazing bar connector set ZS8300, ZS8303

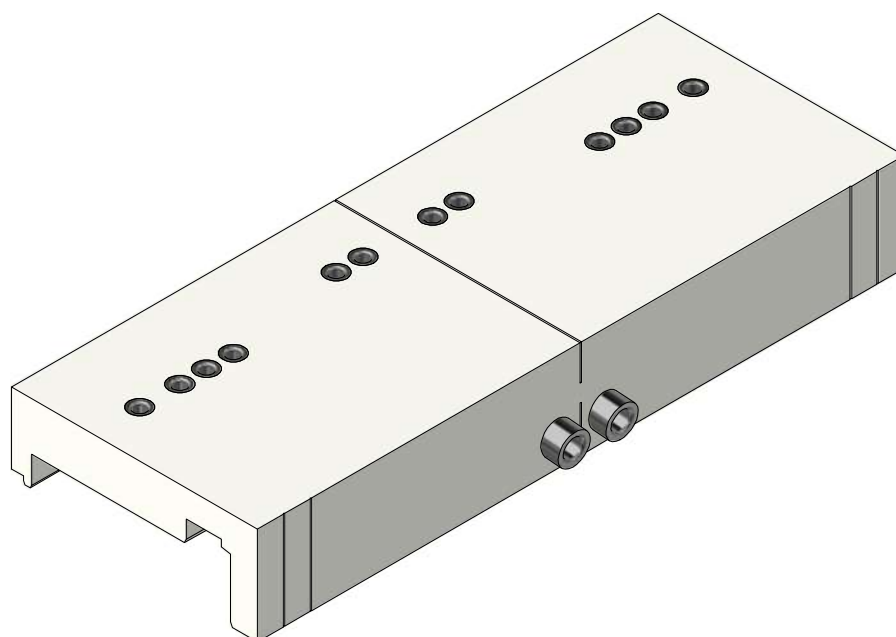

**MT7130**

Drilling jig door threshold ZS7130

for frames HO8020, HO8030, HO9020, HO9030

and fixed mullions HO8310, HO8320, HO9310, HO9320, HO9340

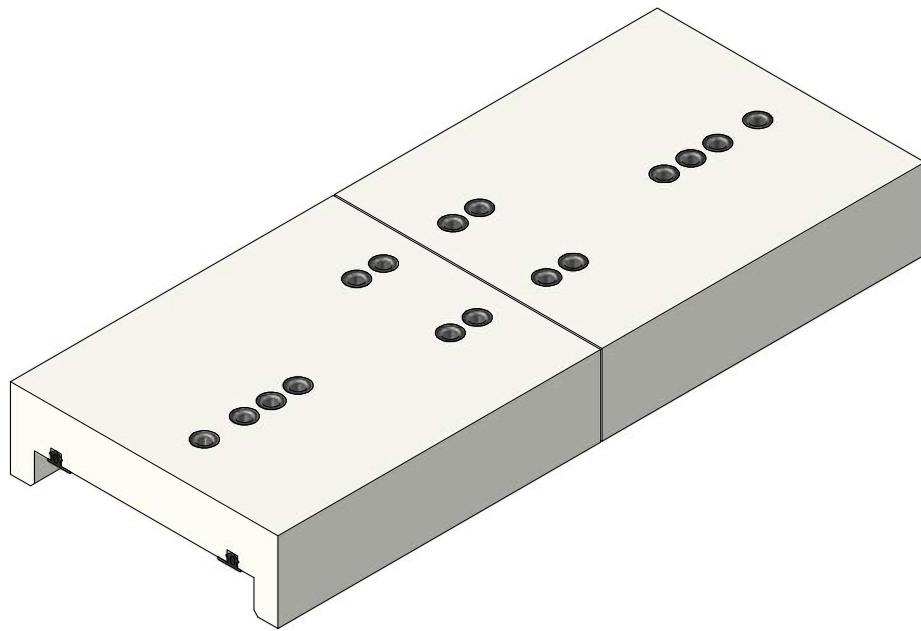

**MT7125**

Drilling jig door threshold ZS7125

for threshold holder sets ZS7525, ZS7535

or

for frames HO8020, HO8030, HO9020, HO9030

and fixed mullions HO8310, HO8320, HO9310, HO9320, HO9340

(Outward-opening door)



**MT9940**

Drilling jig door thresholds ZS7110, ZS7120

for threshold holder sets

ZS7520, ZS7530, ZS7620, ZS7820, ZS7840,

ZS7845

Additional profile  
NP0200

Transport protection  
NP0310

Kick plate  
VA1010, VA8100, VA8110

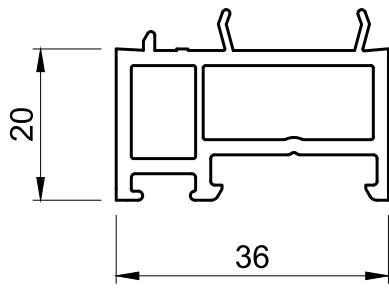

NP0200

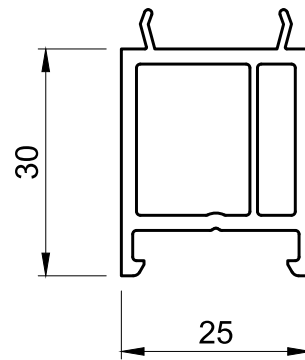

NP0310

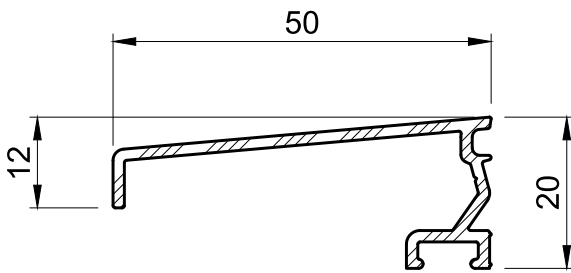

VA1010

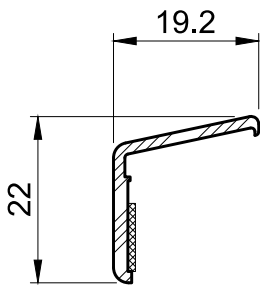

VA8100

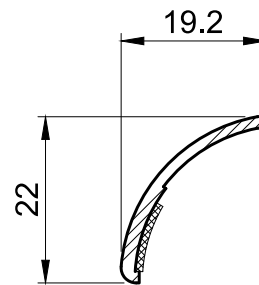

VA8110

Accessories

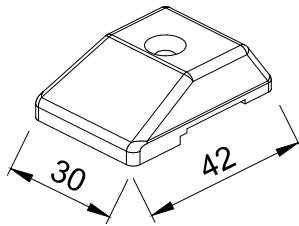

**ES1000**  
Sash-supporter component

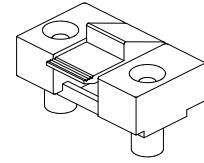

**ES1010**  
Fixed glazing clip

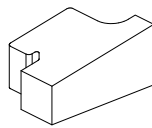

**ES1500**  
Sealing piece  
for Fold&Slide door

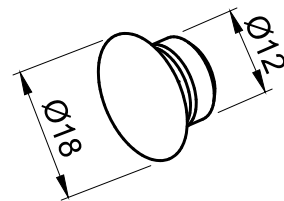

**MZ2880**  
Cover cap

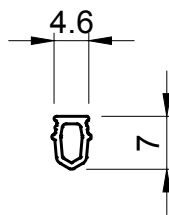

**NP0060**  
Beading

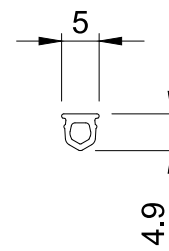

**NP8000**  
Piping

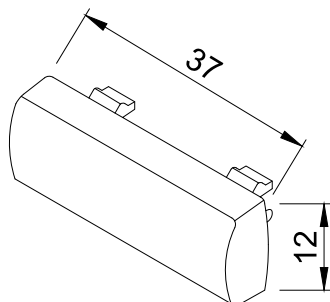

**SG3400**  
Wind cap

Aluminium clip facing shell Frame

VA9022

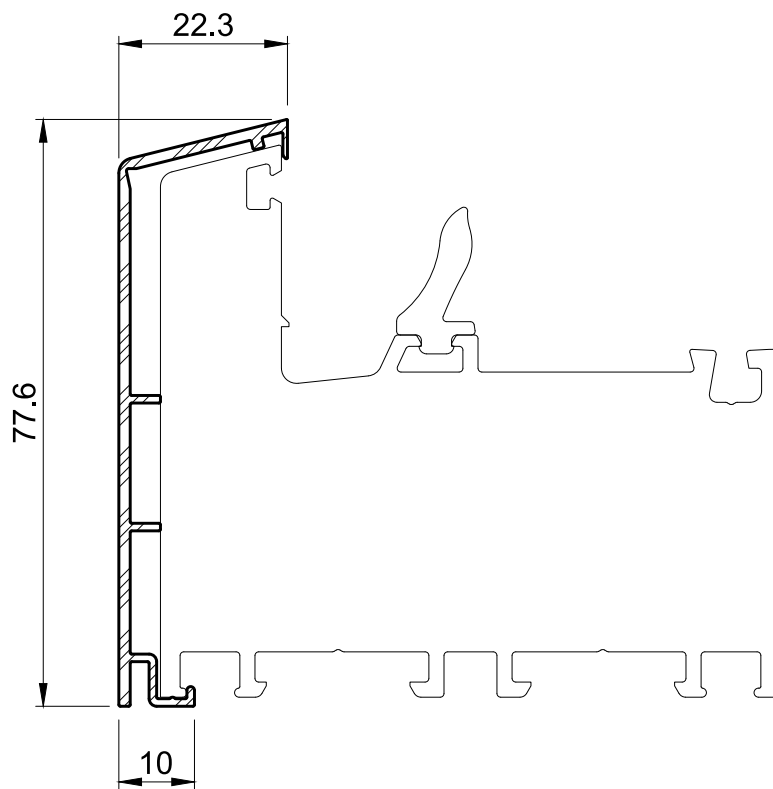

**i** INFO

Application VA9022 with frames HO8020, HO8021, HO9020, HO9021 and old building frames HO9100, HO9110.

Aluminium clip facing shell Frame

**VA9022**

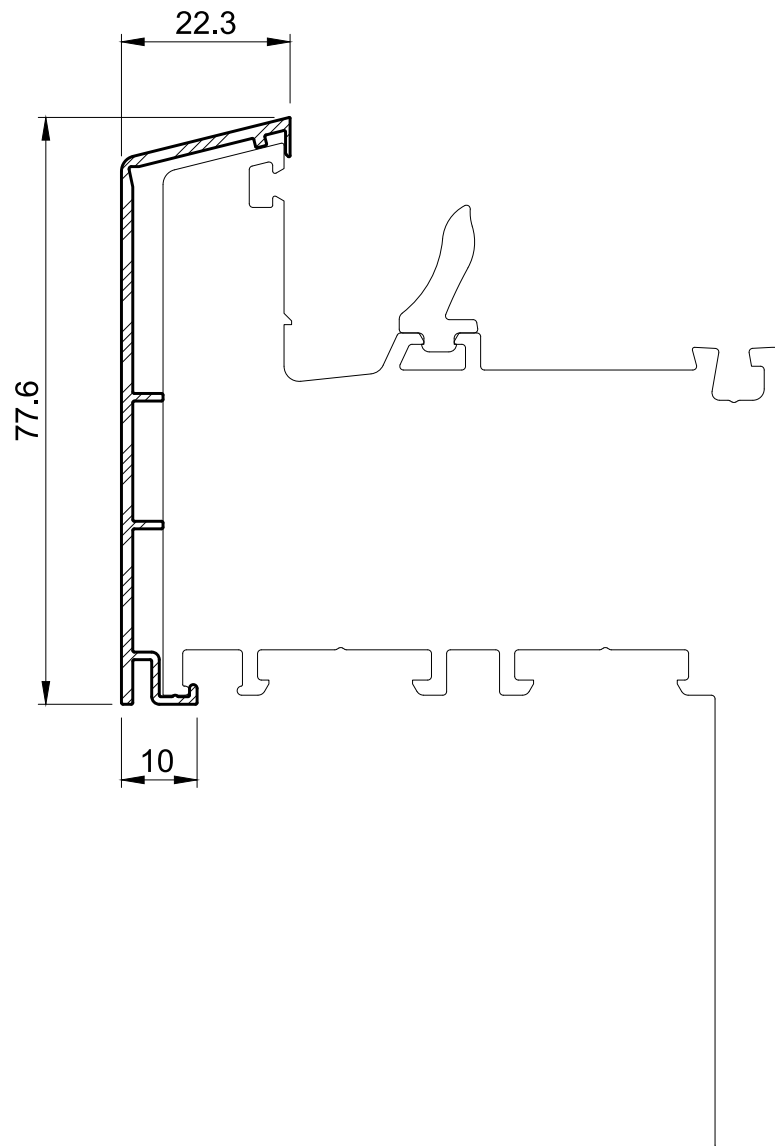

**i** INFO

Application VA9022 with frames HO8020, HO8021, HO9020, HO9021 and old building frames HO9100, HO9110.

Aluminium clip facing shell Frame

VA9032

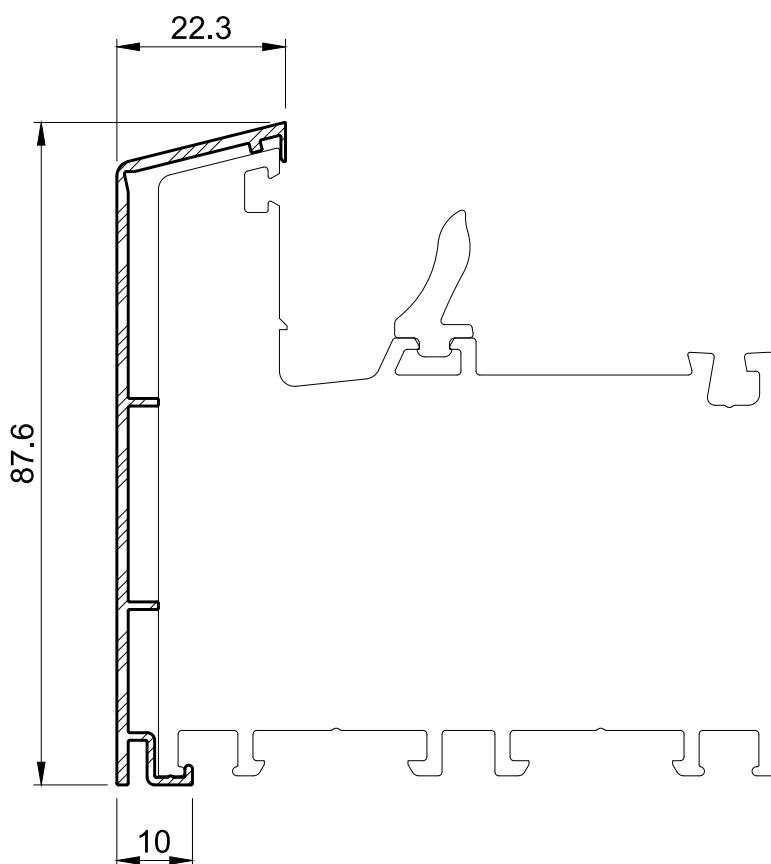

**i** INFO

Application VA9032 for frames HO8030, HO9030.

Aluminium clip facing shell Sash

**VA8523**

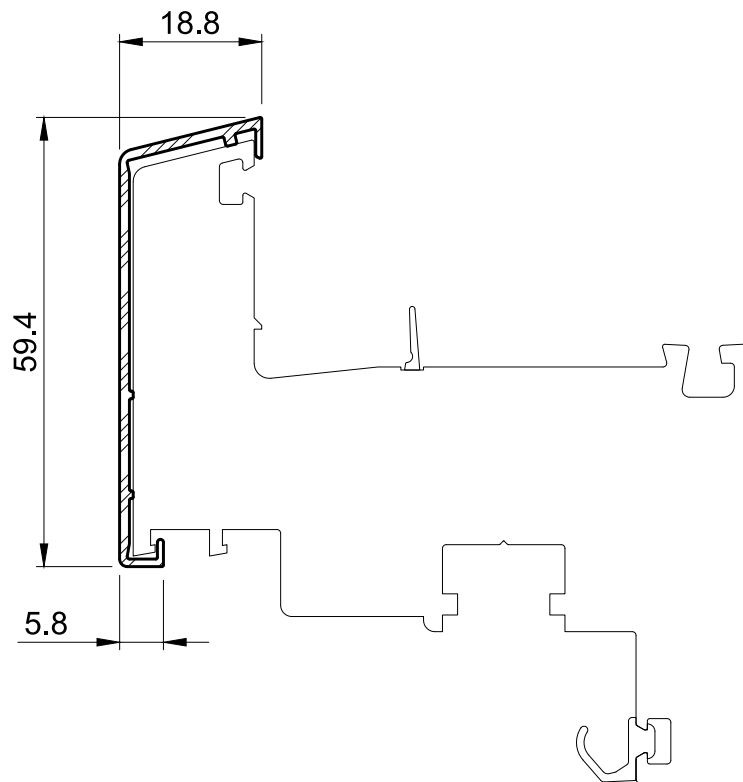

**i** INFO

Application VA8523 with sashes HO8520, HO8521.

Aluminium clip facing shell Sash

VA8532

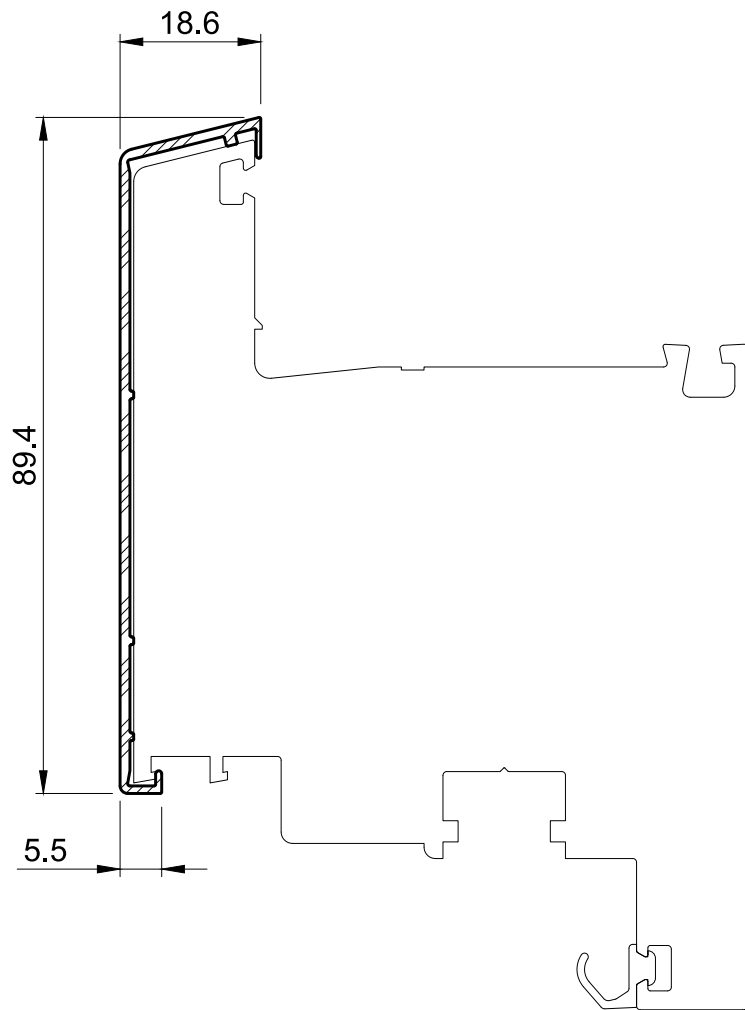

**i** INFO

Application VA8532 for sash HO8530.

Aluminium clip facing shell Fixed mullion, glazing bar

**VA9322**

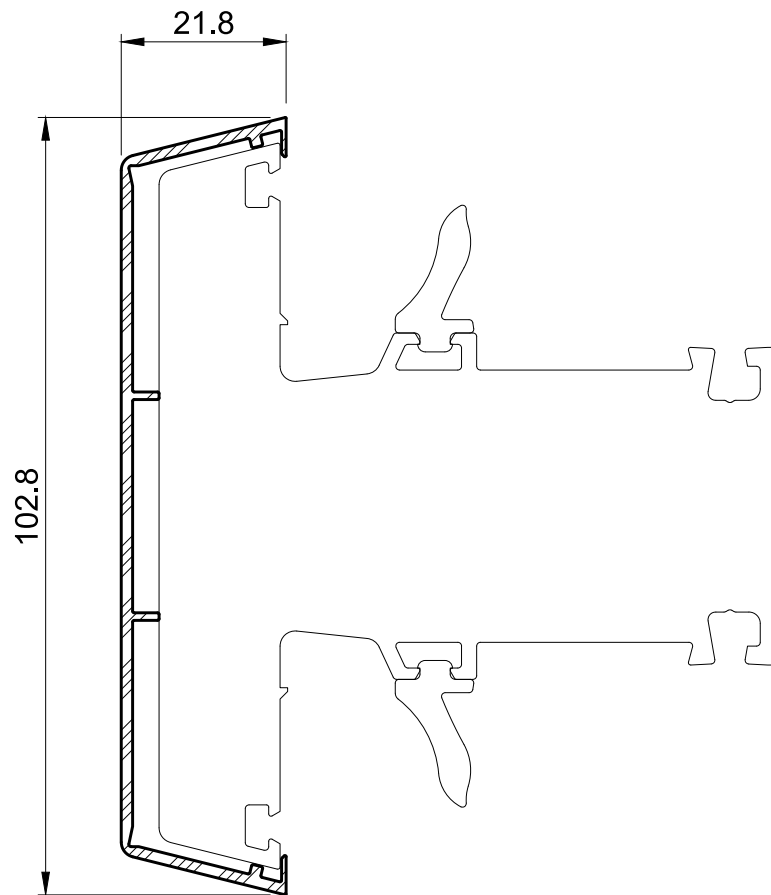

**i** INFO

Application VA9322 with fixed mullions HO8310, HO8320, HO9310, HO9320.

For application as fixed mullion in frame.

Aluminium clip facing shell Fixed mullion, glazing bar

VA8312

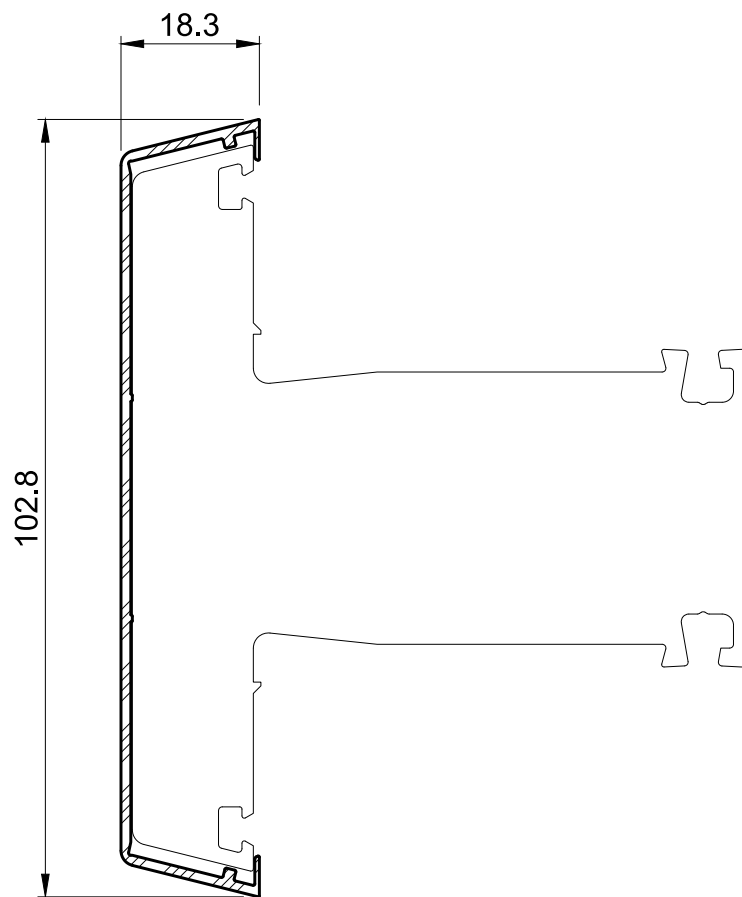
**i** INFO

Application VA8312 with fixed mullions HO8310, HO8320, HO9310, HO9320.

For application as glazing bar in sash.

Aluminium clip facing shell Fixed mullion, glazing bar

**VA9342**

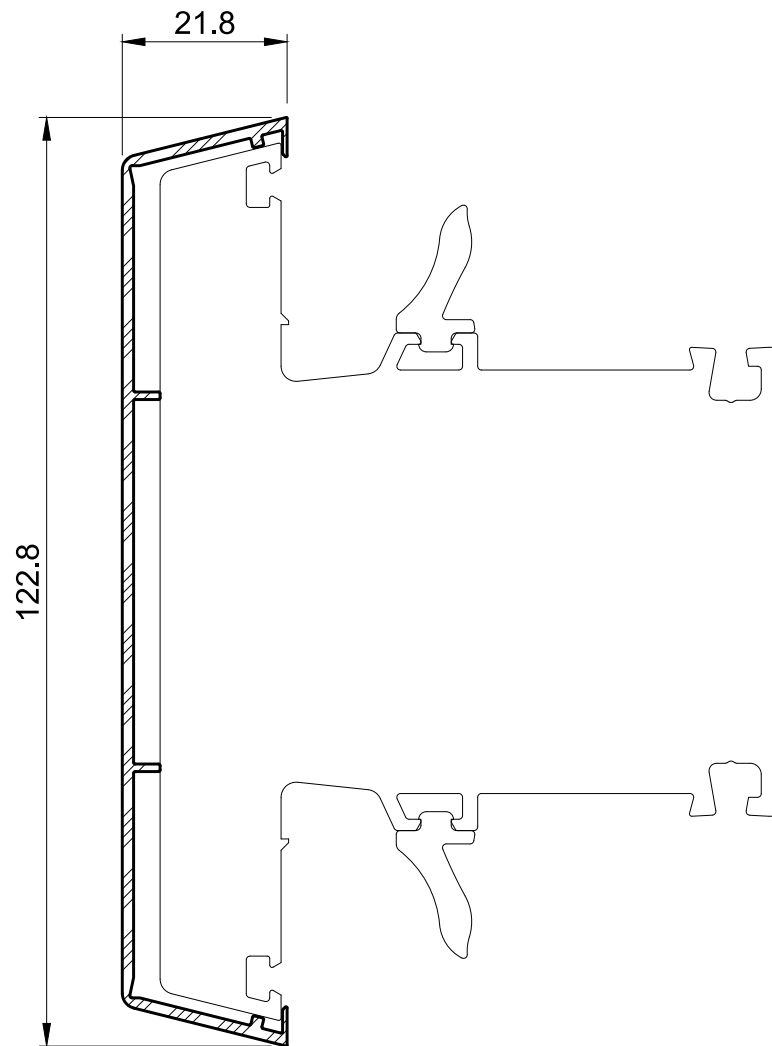

**i** INFO

Application VA9342 with fixed mullions HO9330, HO9340.

For application as fixed mullion in frame.

Aluminium clip facing shell Fixed mullion, glazing bar

VA8302

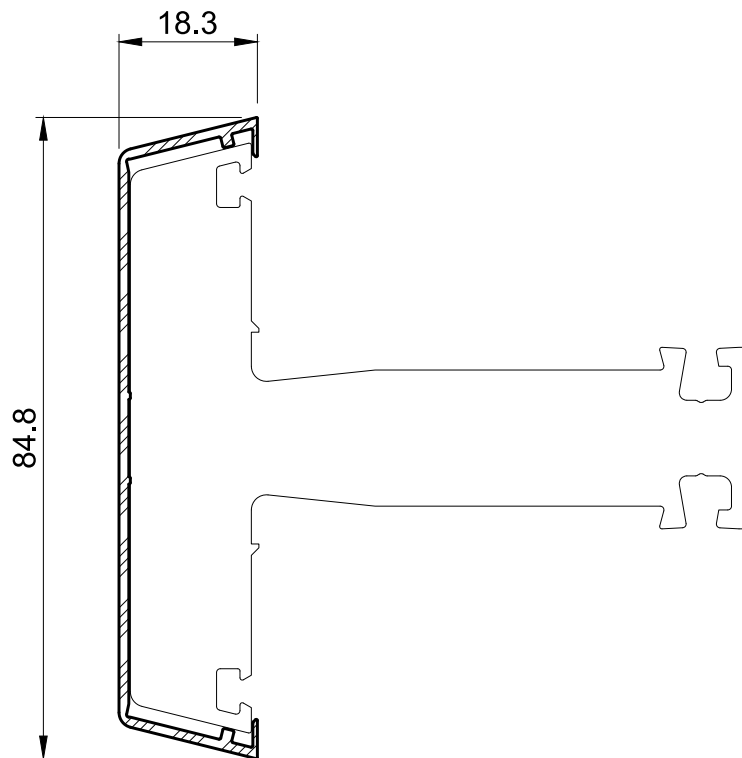
**i** INFO

Application VA8302 for glazing bar HO8300.

For application as glazing bar in sash.

Aluminium clip facing shell right-angled profile

**VA9812**

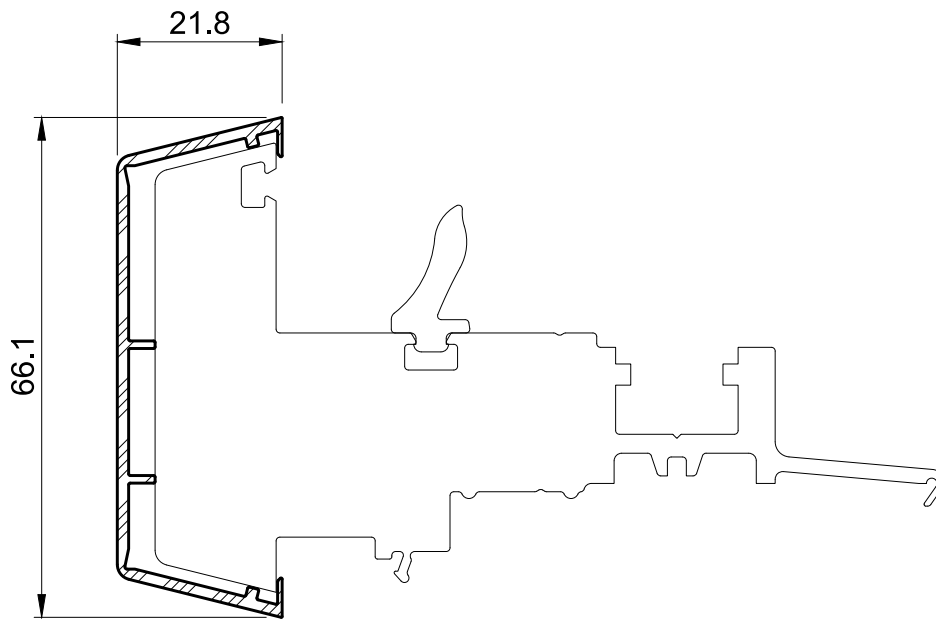

**Accessories** (not to scale)

Faceplate end cover cap

ES9832



**i** **INFO**

Application VA9812 right-angled profile HO9810.

Aluminium clip facing shell right-angled profile

VA9802

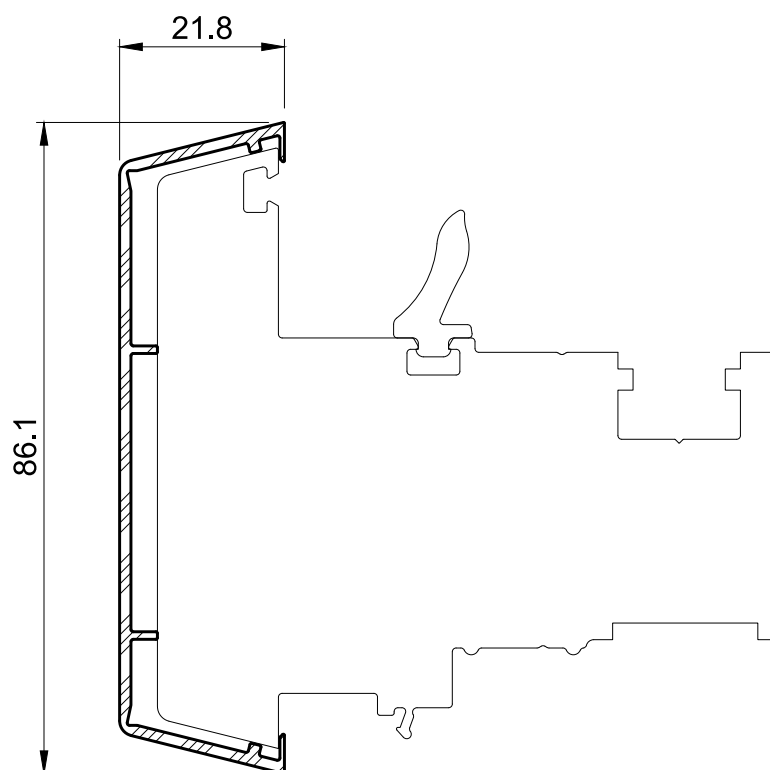

**Accessories** (not to scale)

Faceplate end cover cap

ES9812



**i** INFO

Application VA9802 with right-angled profile HO9800.

Aluminium clip facing shells widening

**VA8303, VA8503**

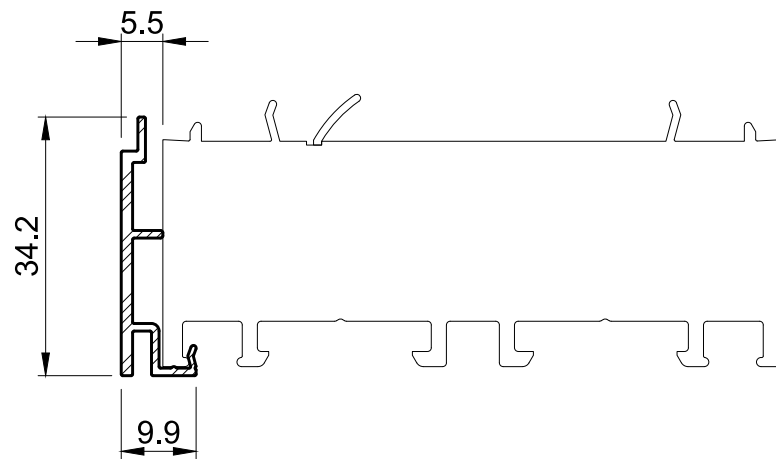

**VA8303**

**i** INFO

Application VA8303 for widening NP8300.

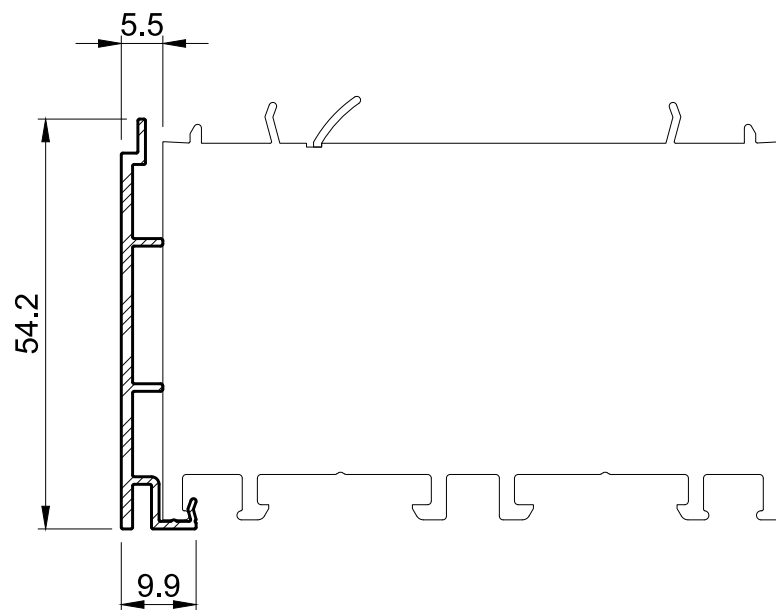

**VA8503**

**i** INFO

Application VA8503 for widening NP8500.

Aluminium clip facing shell widening

VA8703

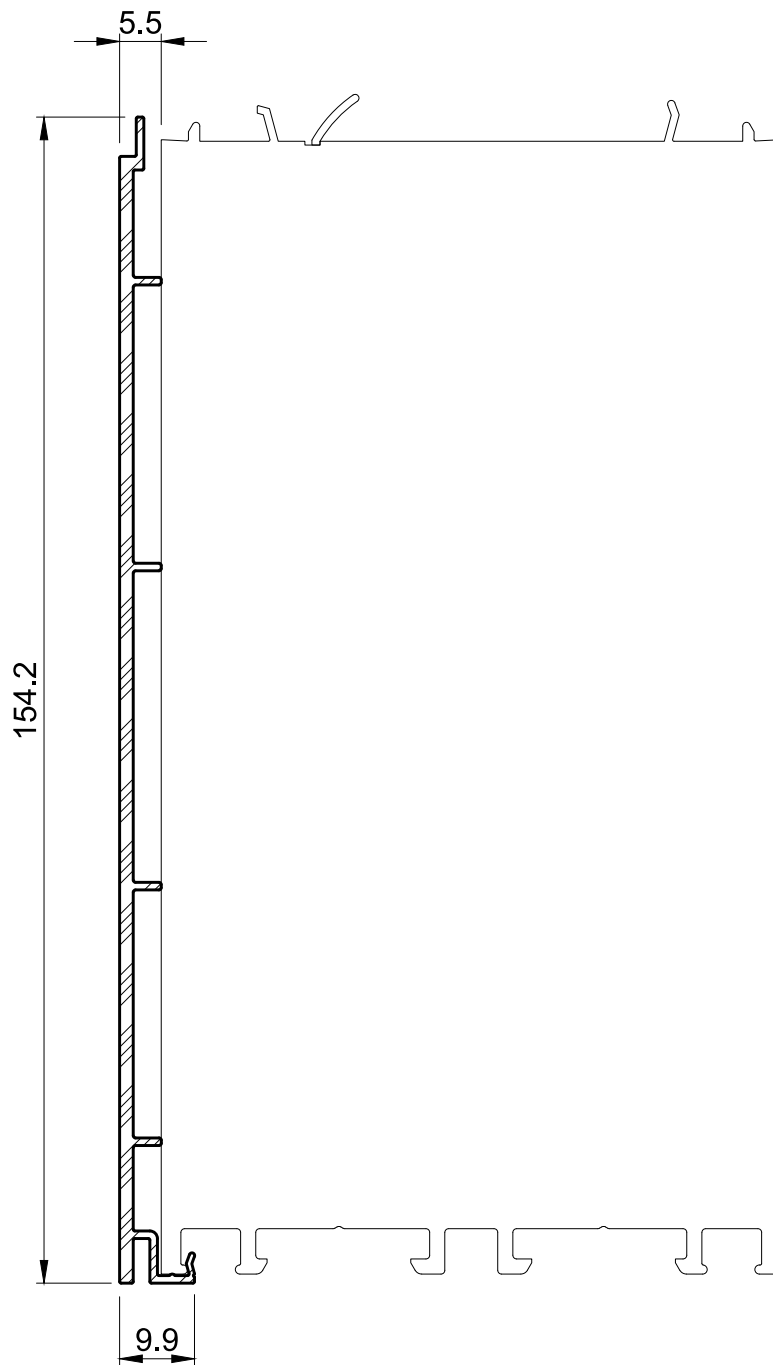

**i** INFO

Application VA8703 for widening NP8700.

Aluminium T-profile  
**VA9410**

Aluminium sheet  
**VA9400**

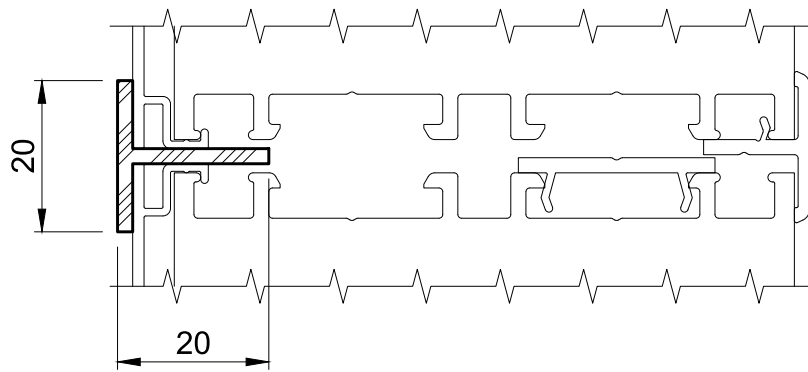

**VA9410**

**i** INFO

Application VA9410 for coupling NP0190.

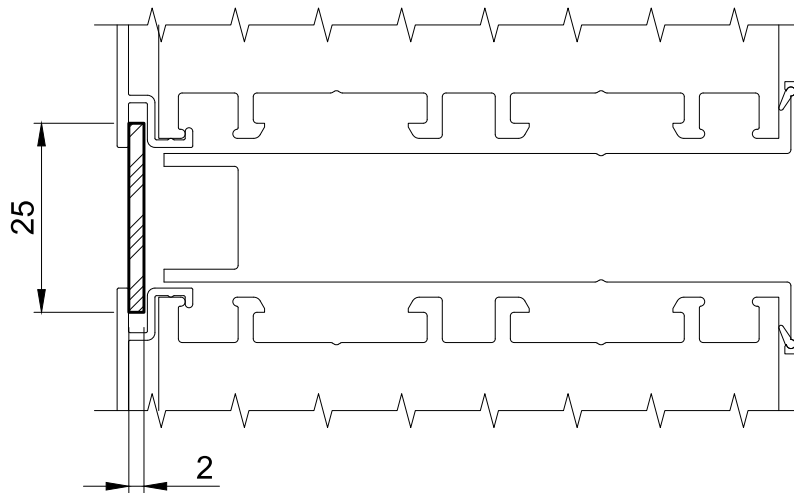

**VA9400**

**i** INFO

Application VA9400 for coupling NP8170.

Gaskets  
**DP2720, DP2730**

Distance compensation  
**MT9080**

Faceplate end cover caps  
**ES9832, ES9812, ZS9812, ZS9802**

Gaskets for aluminium clip facing shells  
 PVC-P

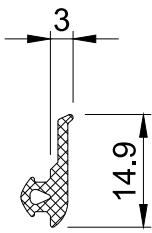

**DP2720**

Stopper gasket  
 for frame, fixed mullion, faceplate

Colour: black, grey

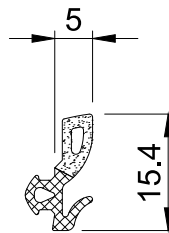
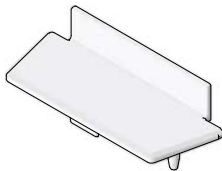

**DP2730**

Glazing gasket  
 for frame, sash, glazing bar, fixed mullion

Colour: black, grey

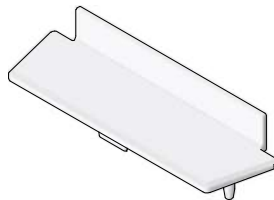

**MT9080**

Distance compensation

Colour: black

**ES9832**

Faceplate end cover cap  
 for faceplate HO9810

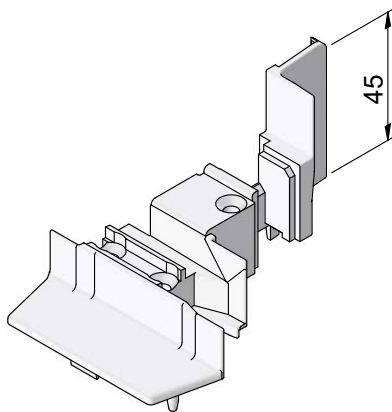

**ES9812**

Faceplate end cover cap  
 for faceplate HO9800

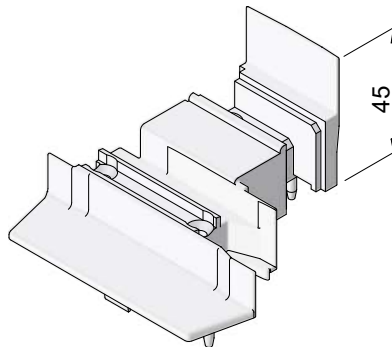

**ZS9812**

Faceplate end cover cap set for  
 HO9810

**ZS9802**

Faceplate end cover cap set for  
 HO9800

## Chapter 4

**Profile combinations**

<b>Designation</b>	<b>Page</b>
Fixed glazing frame	1
Sash - frame	10
Fixed glazing fixed mullion	73
Fixed glazing bar	77
Sash - fixed mullion	78
Sash - faceplate	126
Door thresholds	145
Rebate reinforcement / Rebate corner angle	174
Widenings	176
Sill connection	179
Couplings	184
Corner connections	190
Static profiles (pilaster strips)	193
Cladding profiles	195
Roller shutter guides	196
Aluminium clip facing shells	200



Frame

HO9020 (HO9021)

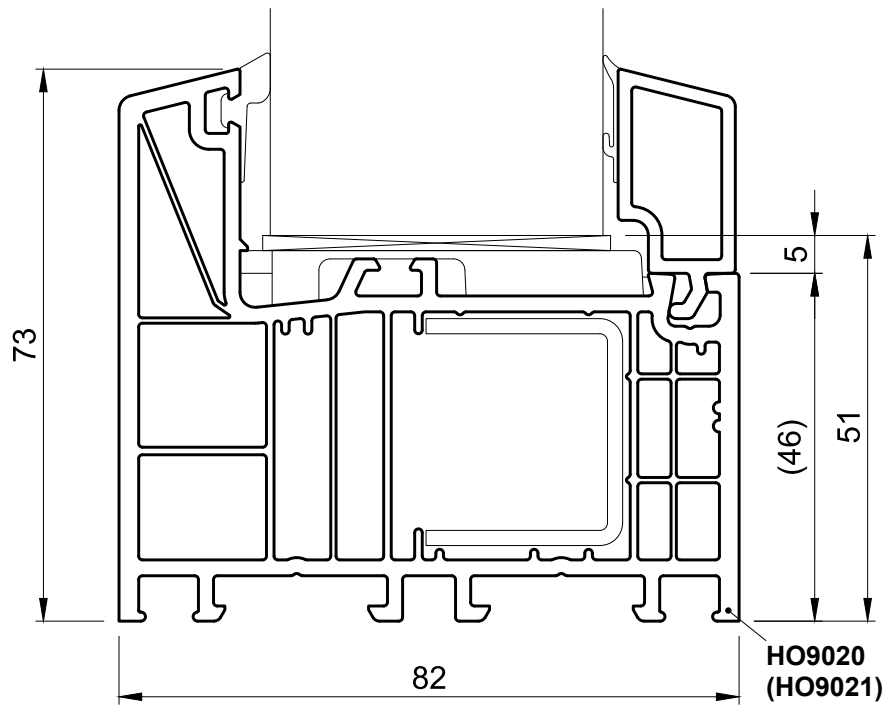

Frame

HO8020 (HO8021)

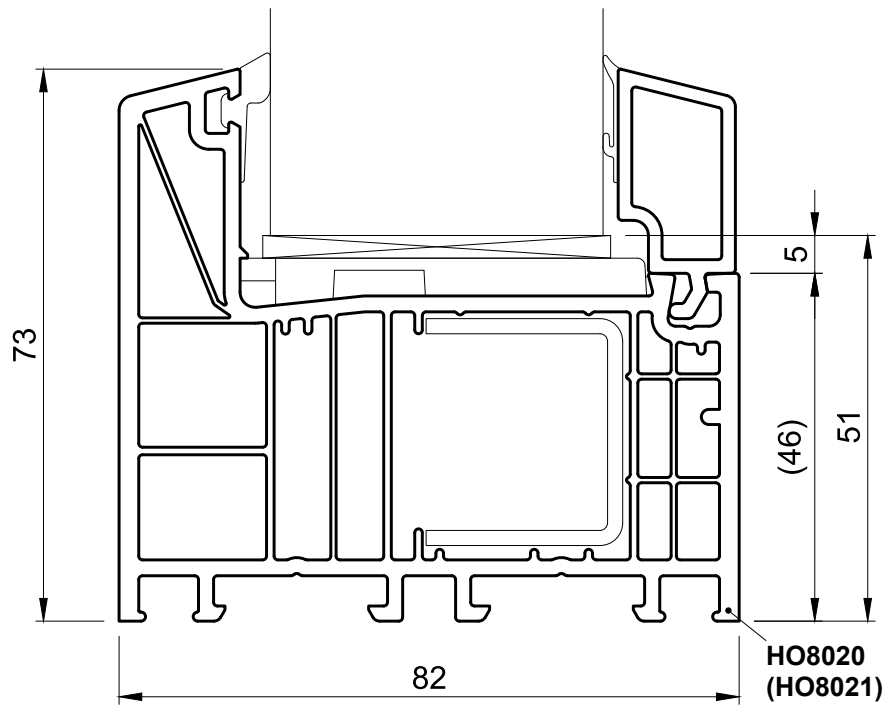

Frame

**HP9220**

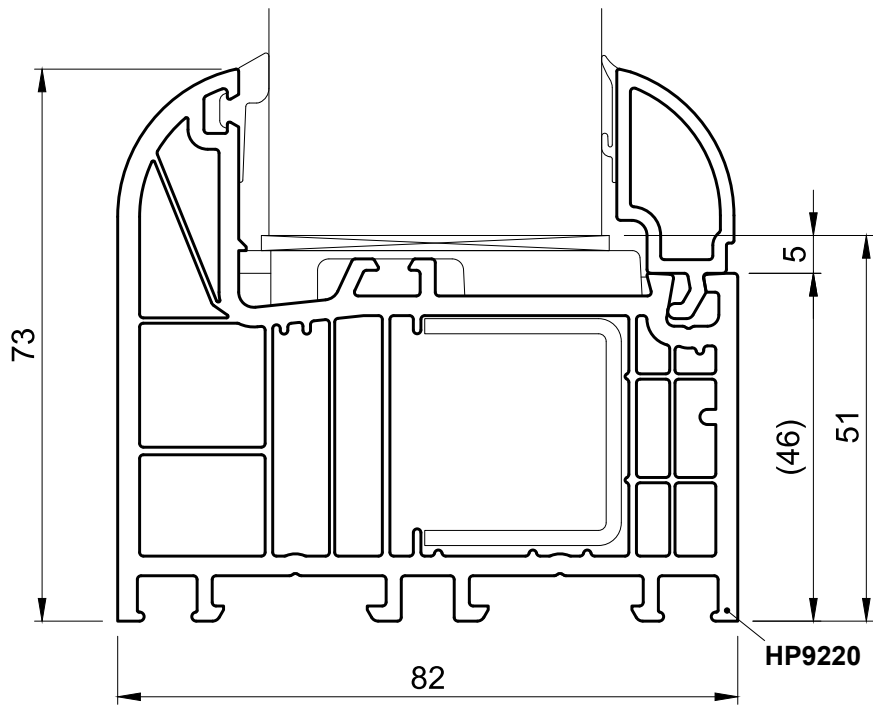

Frame  
HO9030

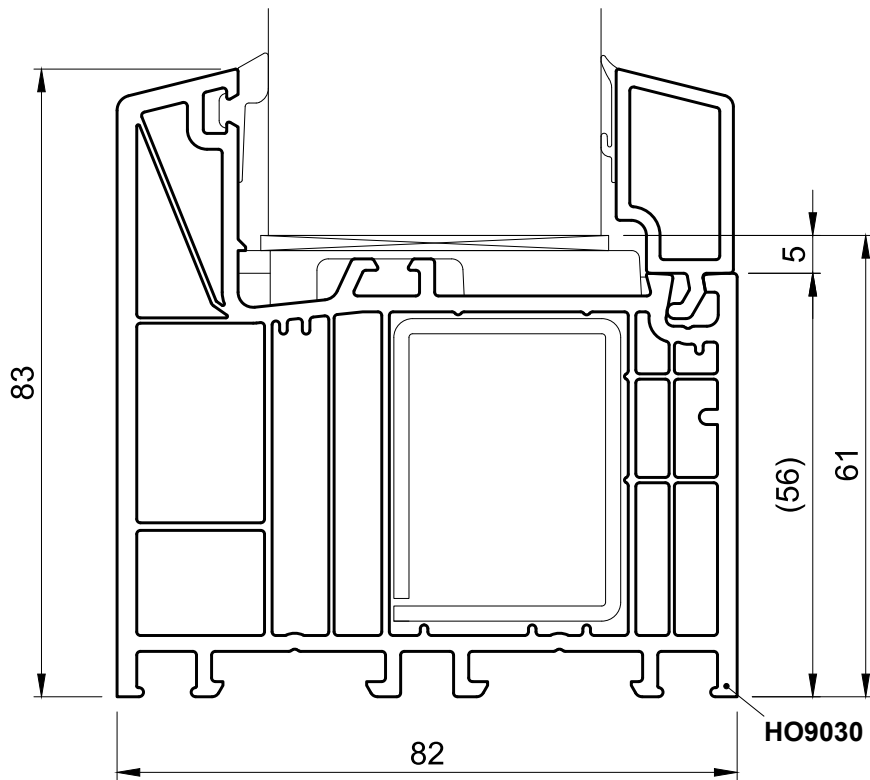

Frame  
**HO8030**

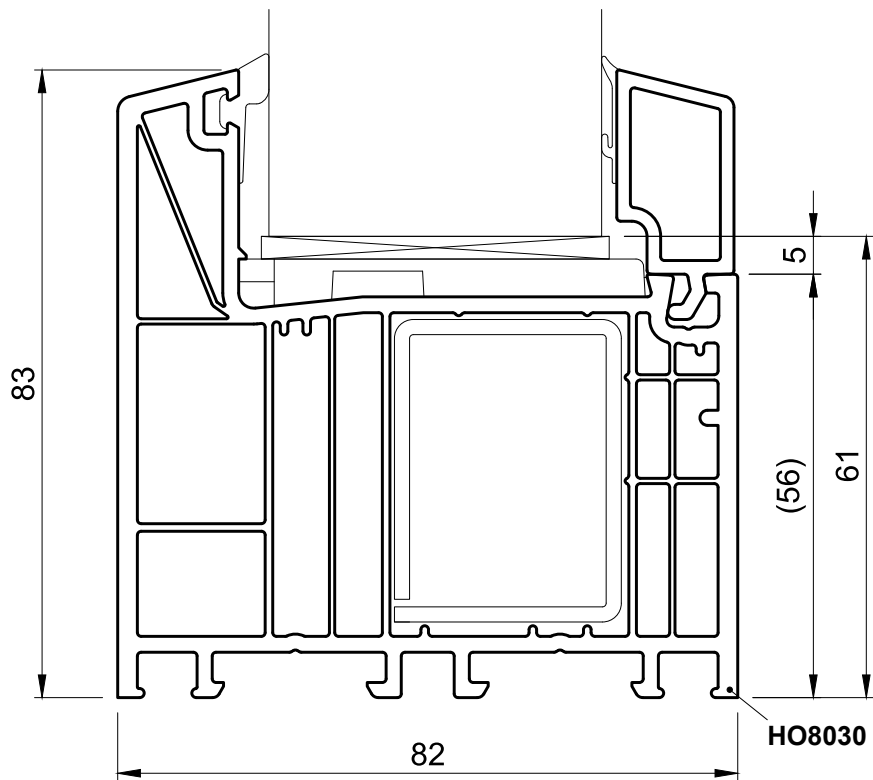

Frame  
HO9050

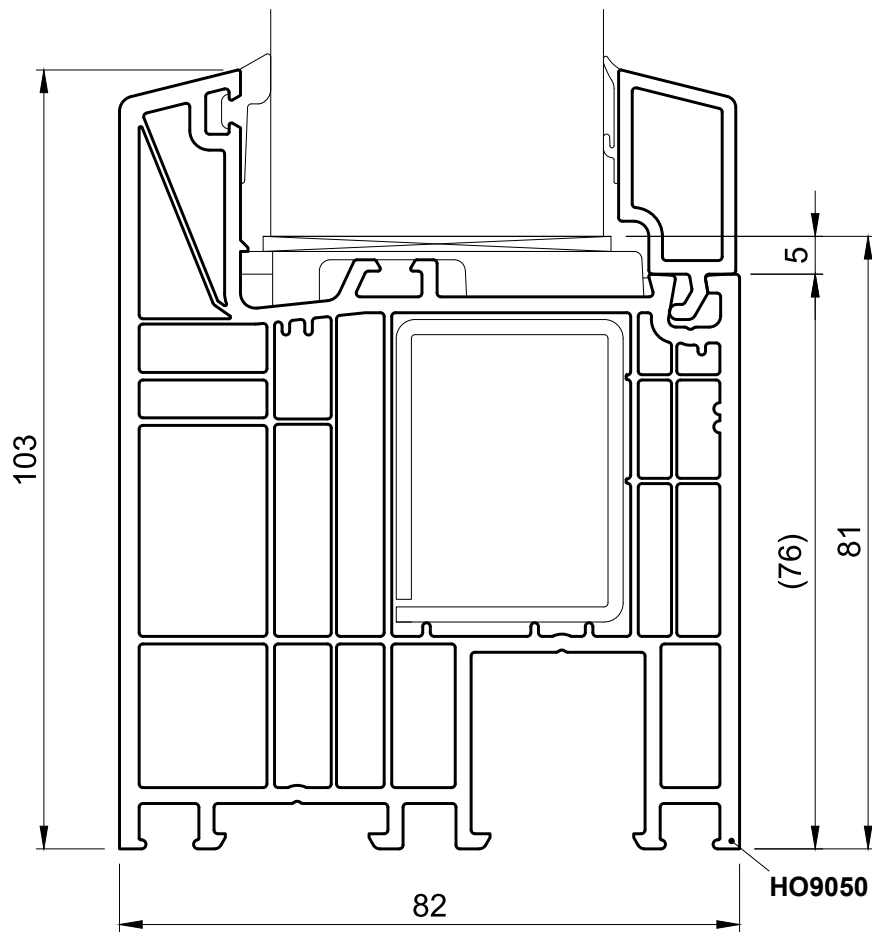

Old building frame

HO9110

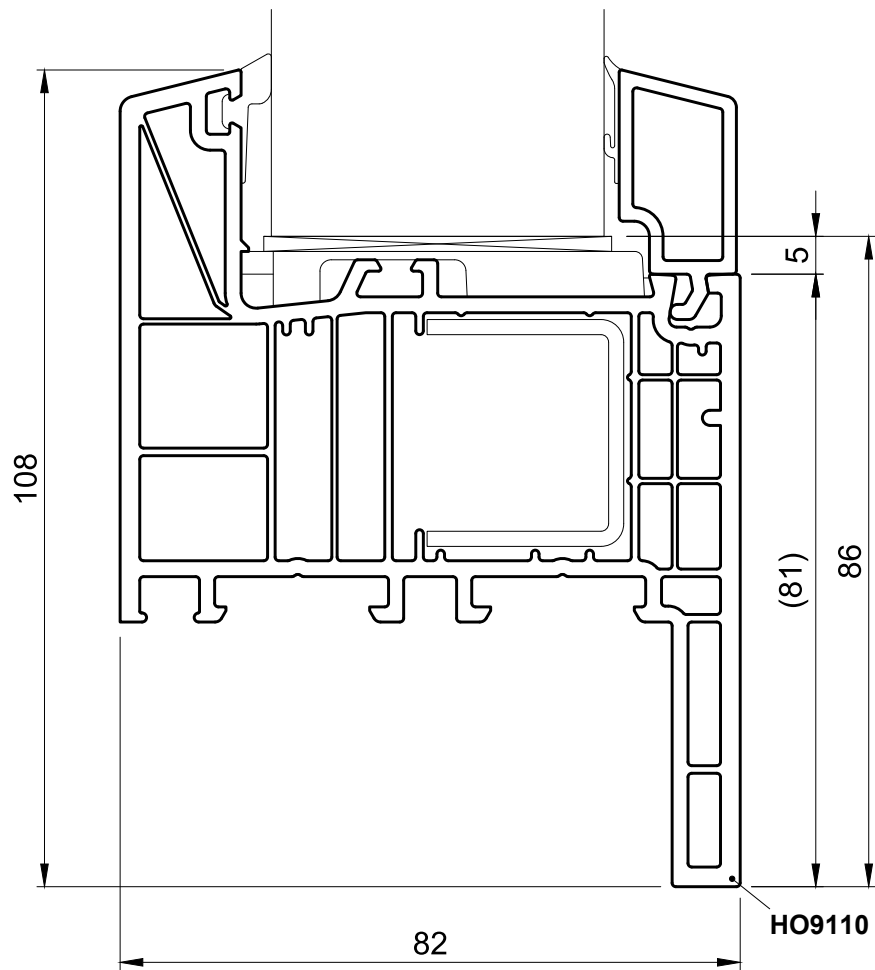

Old building frame

HO9120

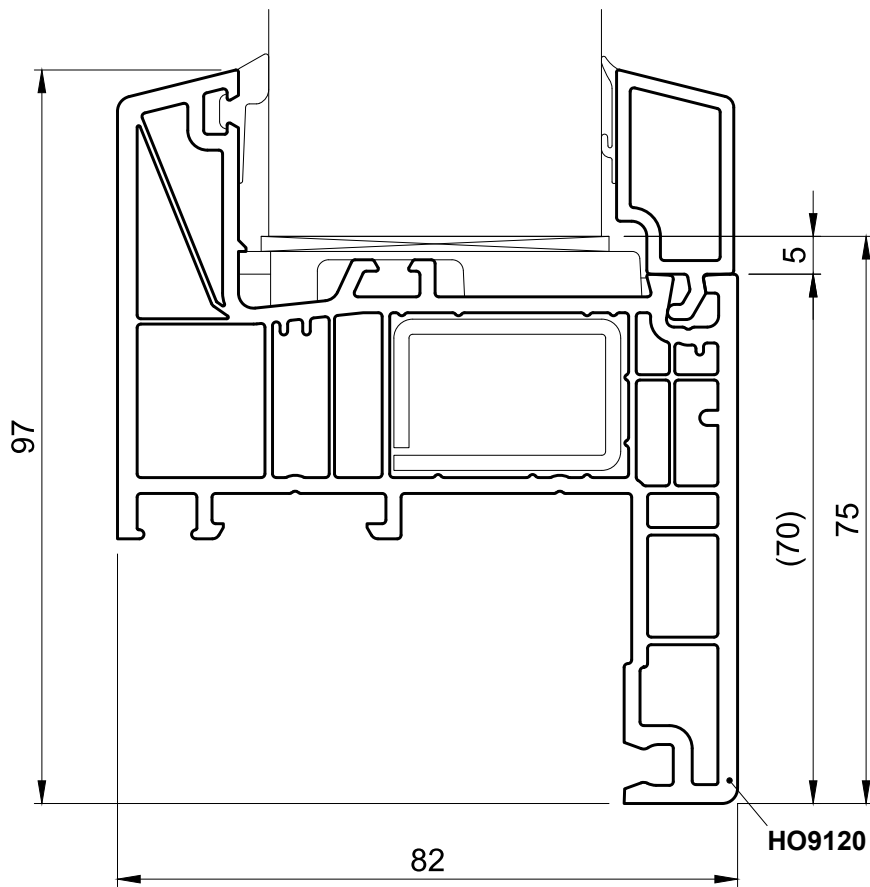

Old building frame

**HO9100**

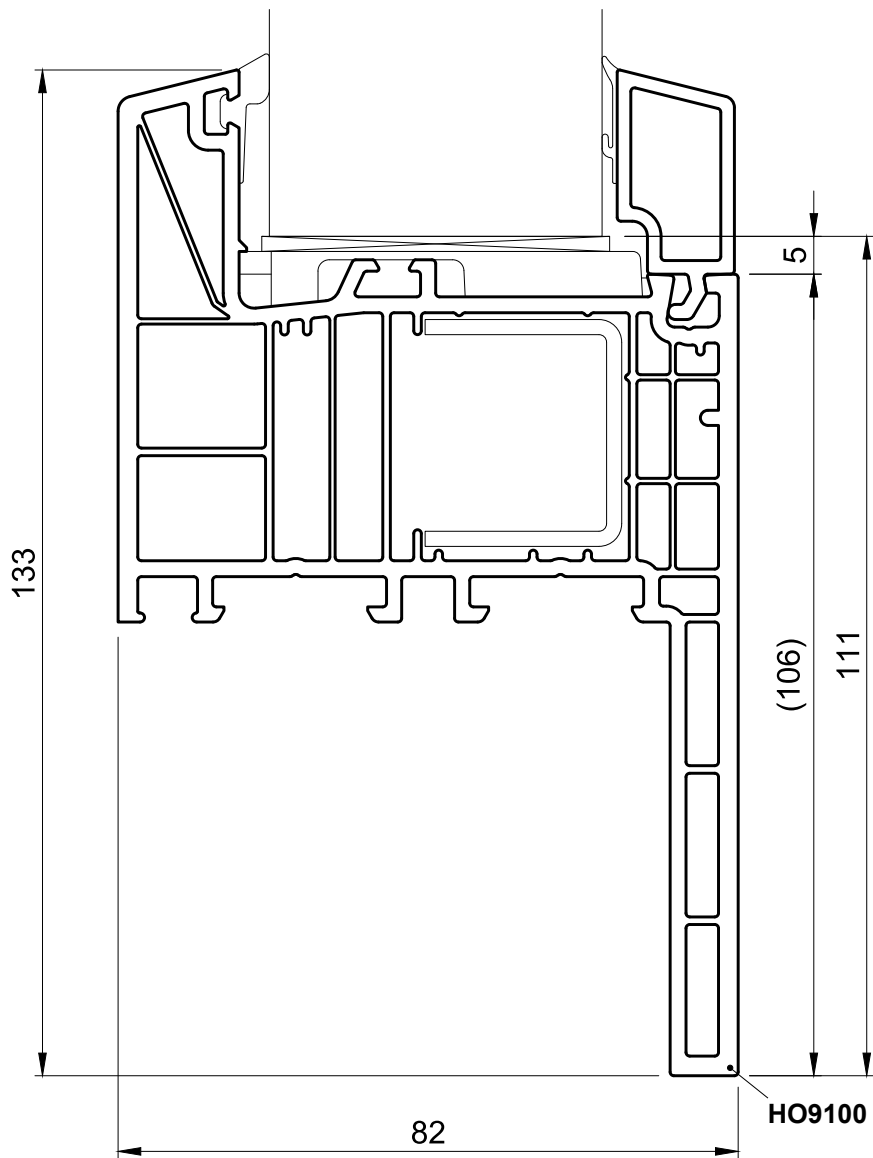

Sash  
HO8510

Frame  
HO9020 (HO9021)

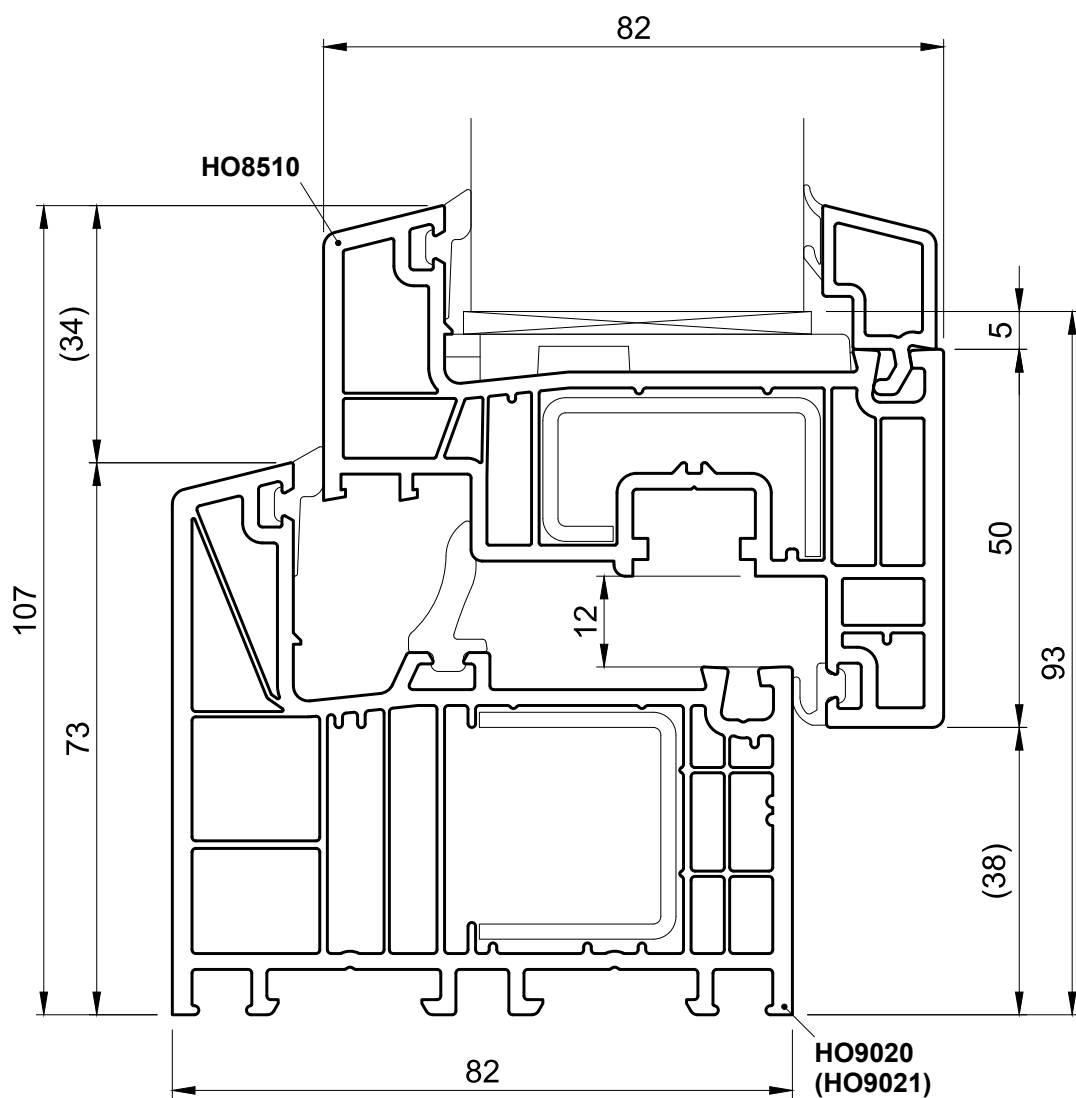

Sash  
**HO8510**

Frame  
**HO8020 (HO8021)**

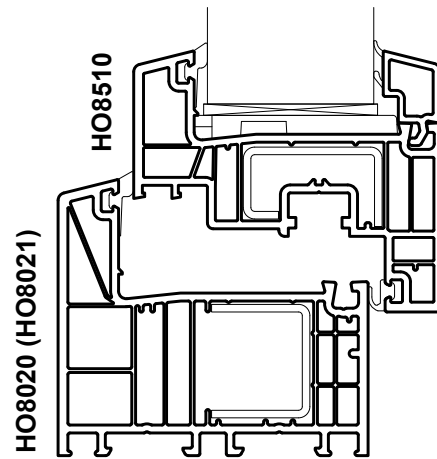

Sash  
HO8510

Frame  
HO9030, HO8030

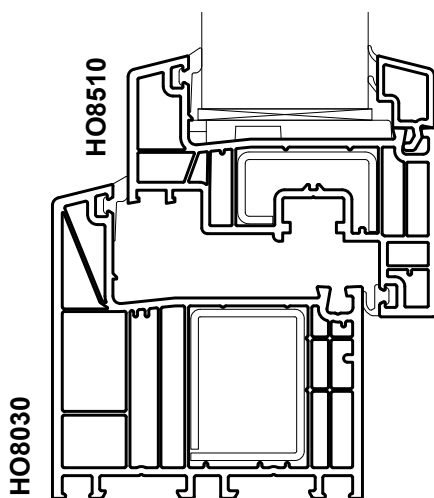
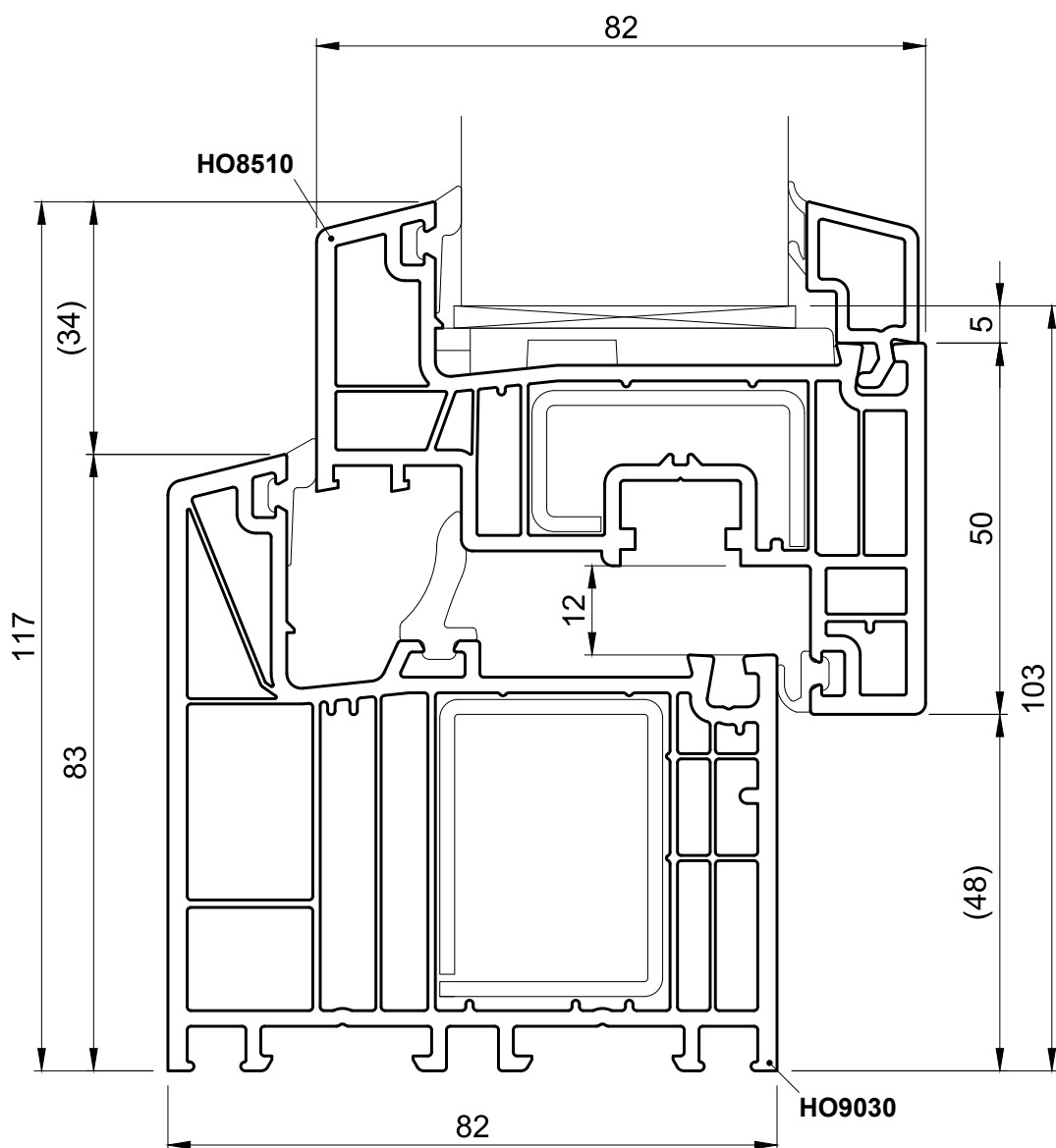

Sash  
HO8510

Frame  
HO9050

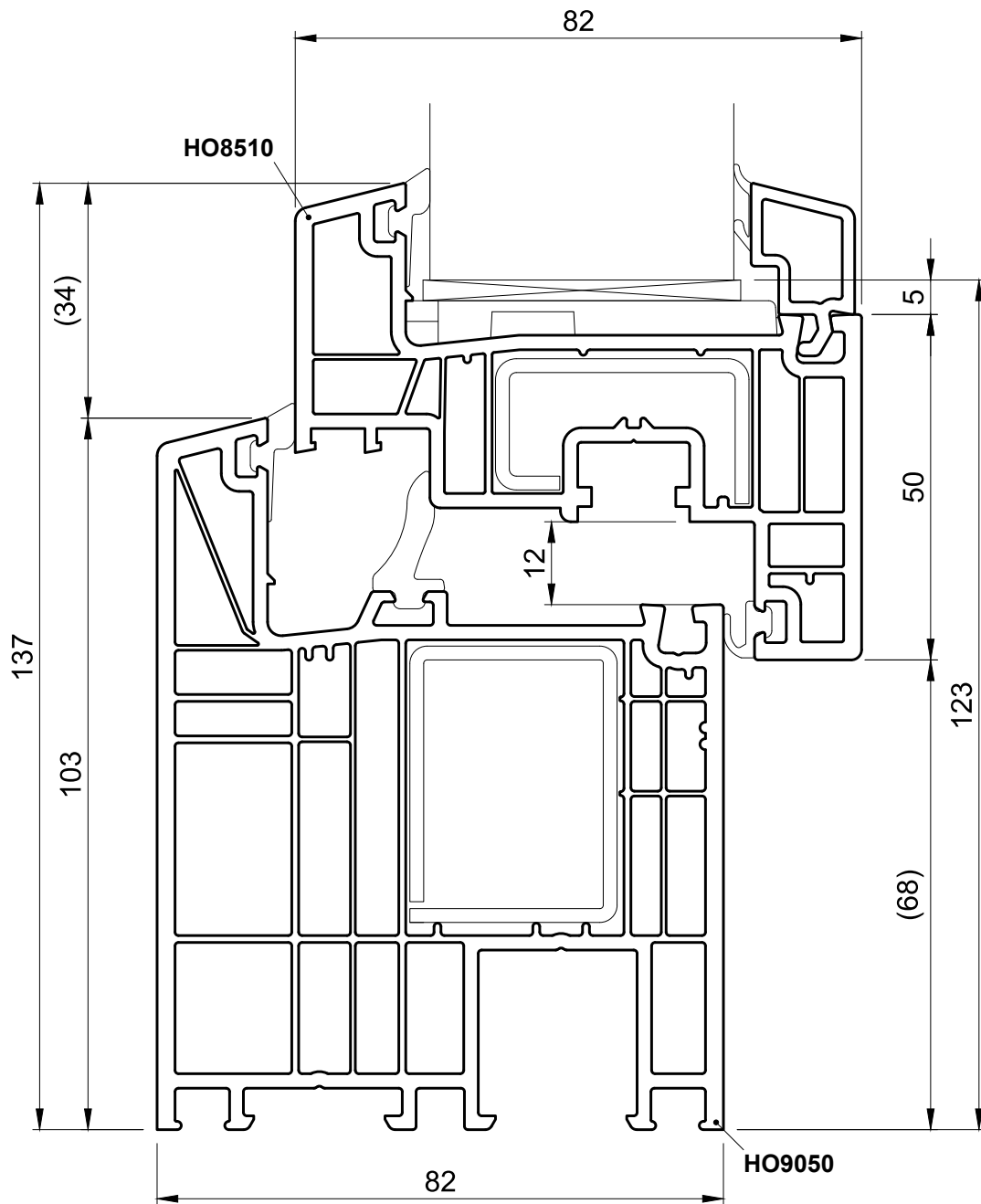

Sash  
HO8510

Old building frame  
HO9110

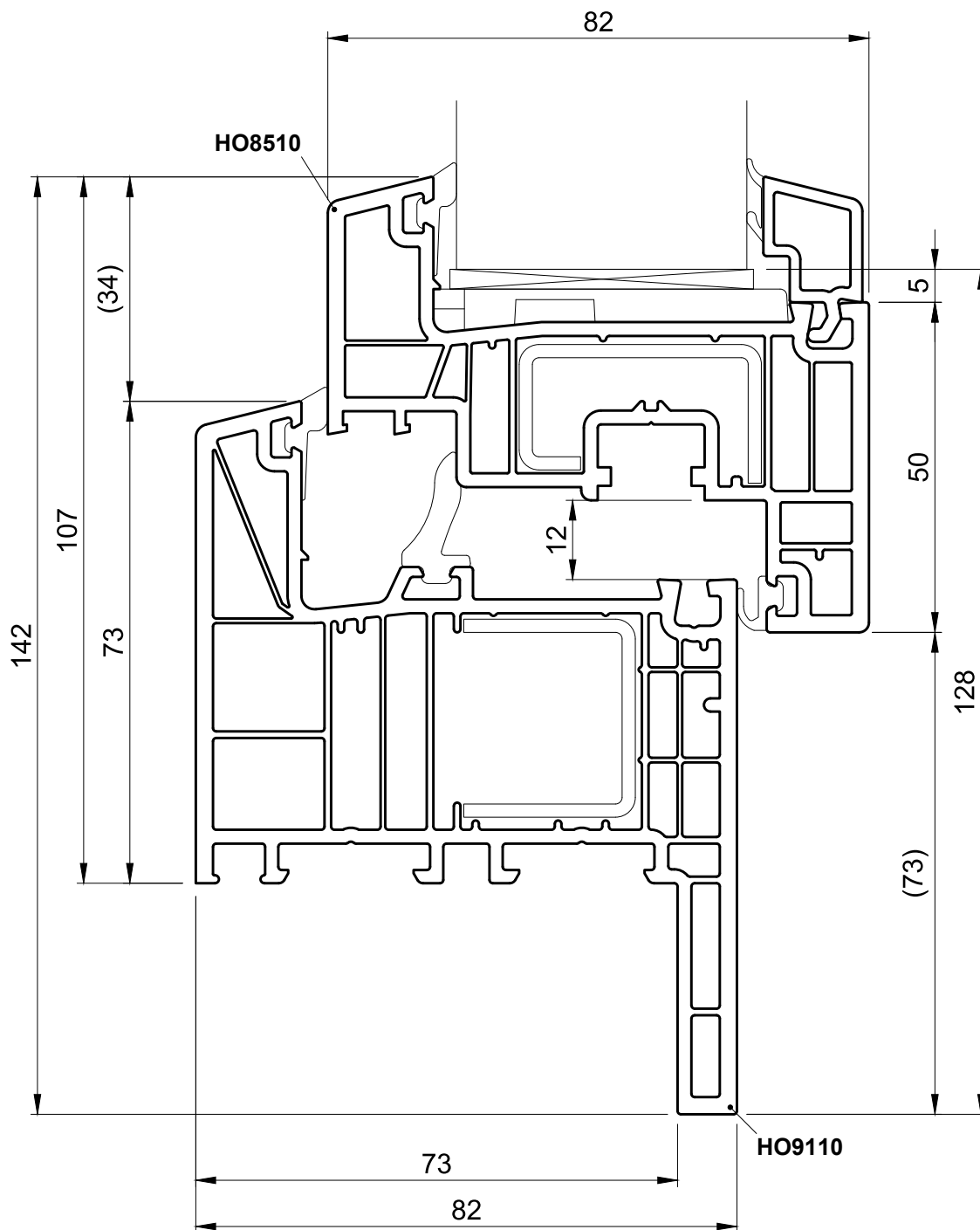

Sash  
HO8510

Old building frame  
HO9120

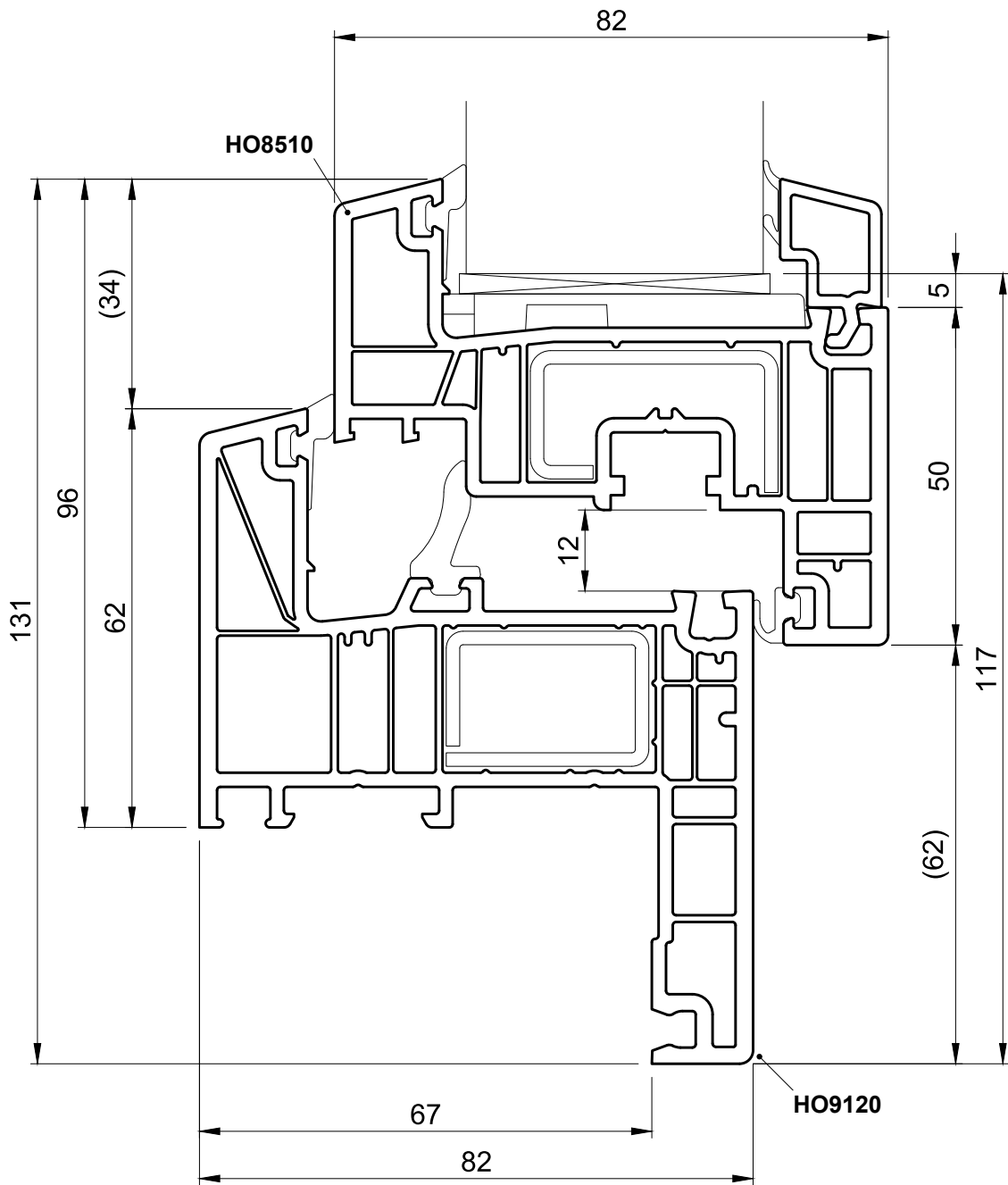

Sash  
HO8510

Old building frame  
HO9100

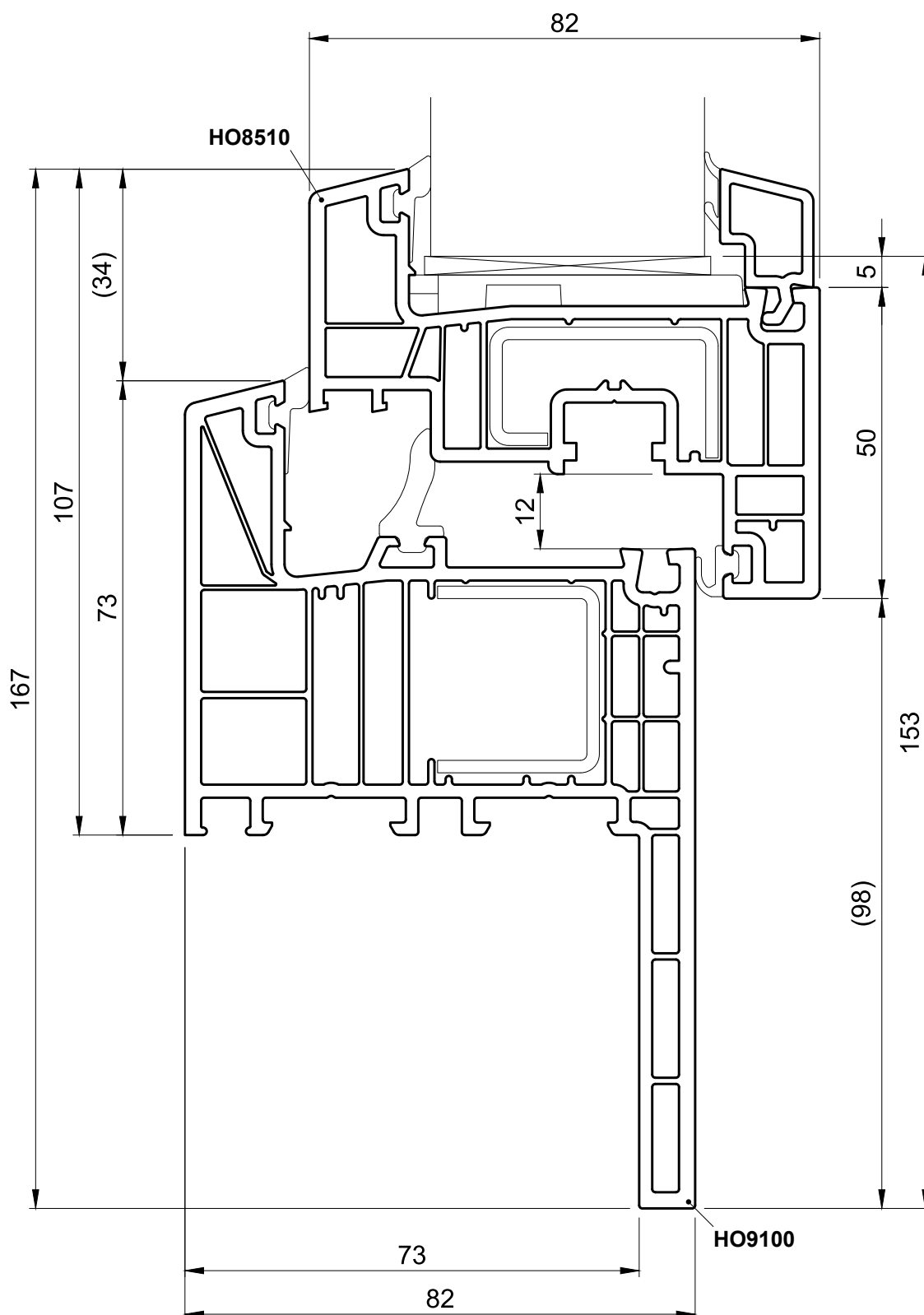

Sash  
HO8520 (HO8521, HP8520)

Frame  
HO9020, HO9021

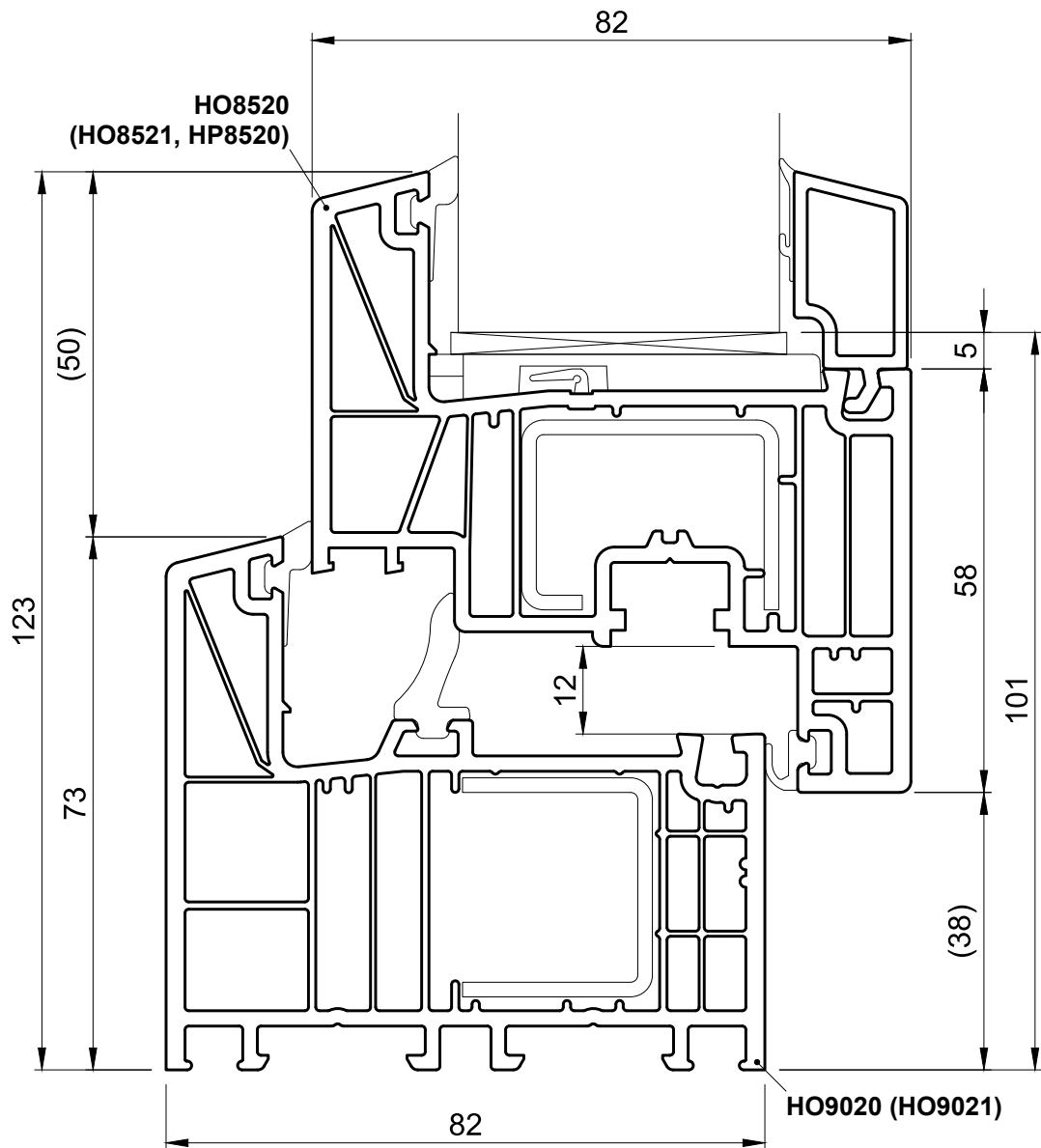

Sash  
HO8520 (HO8521)

Frame  
HO8020, HO8021

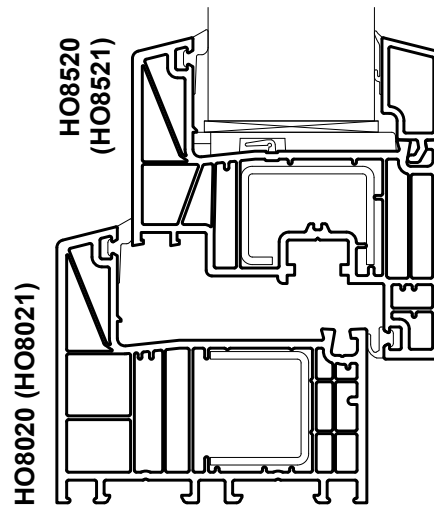

Sash  
HO8520 (HO8521, HP8520)

Frame  
HO9030

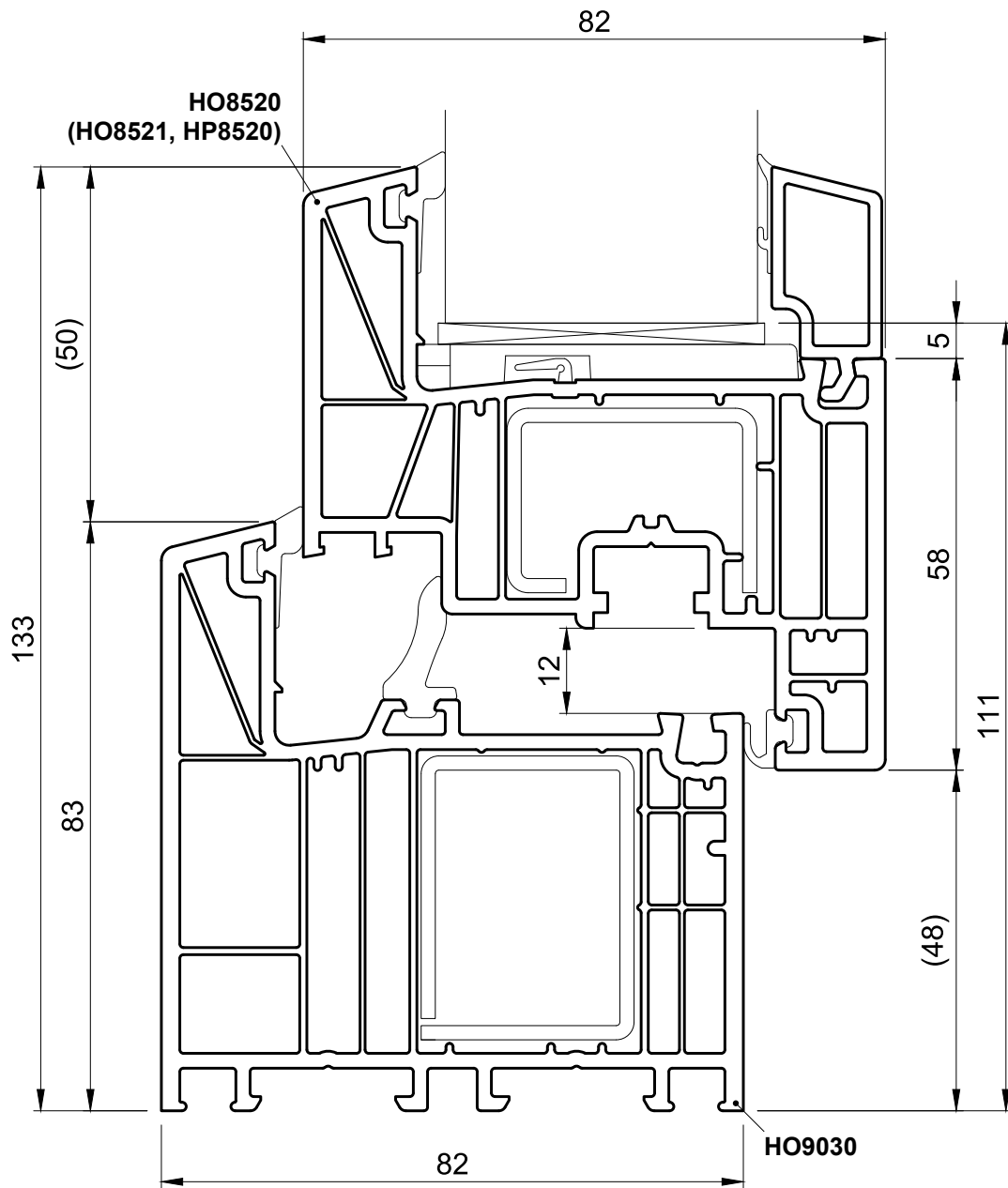

Sash  
HO8520 (HO8521)

Frame  
HO8030

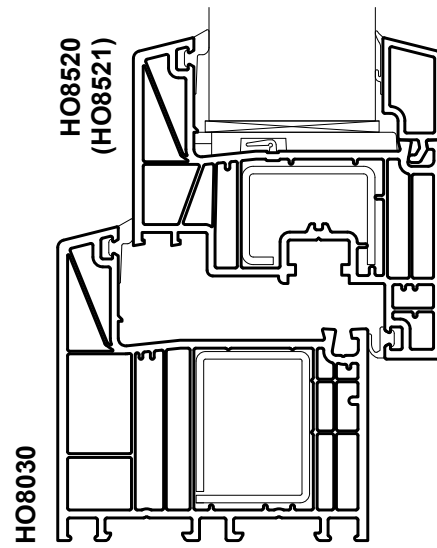

Sash  
HO8520 (HO8521, HP8520)

Frame  
HO9050

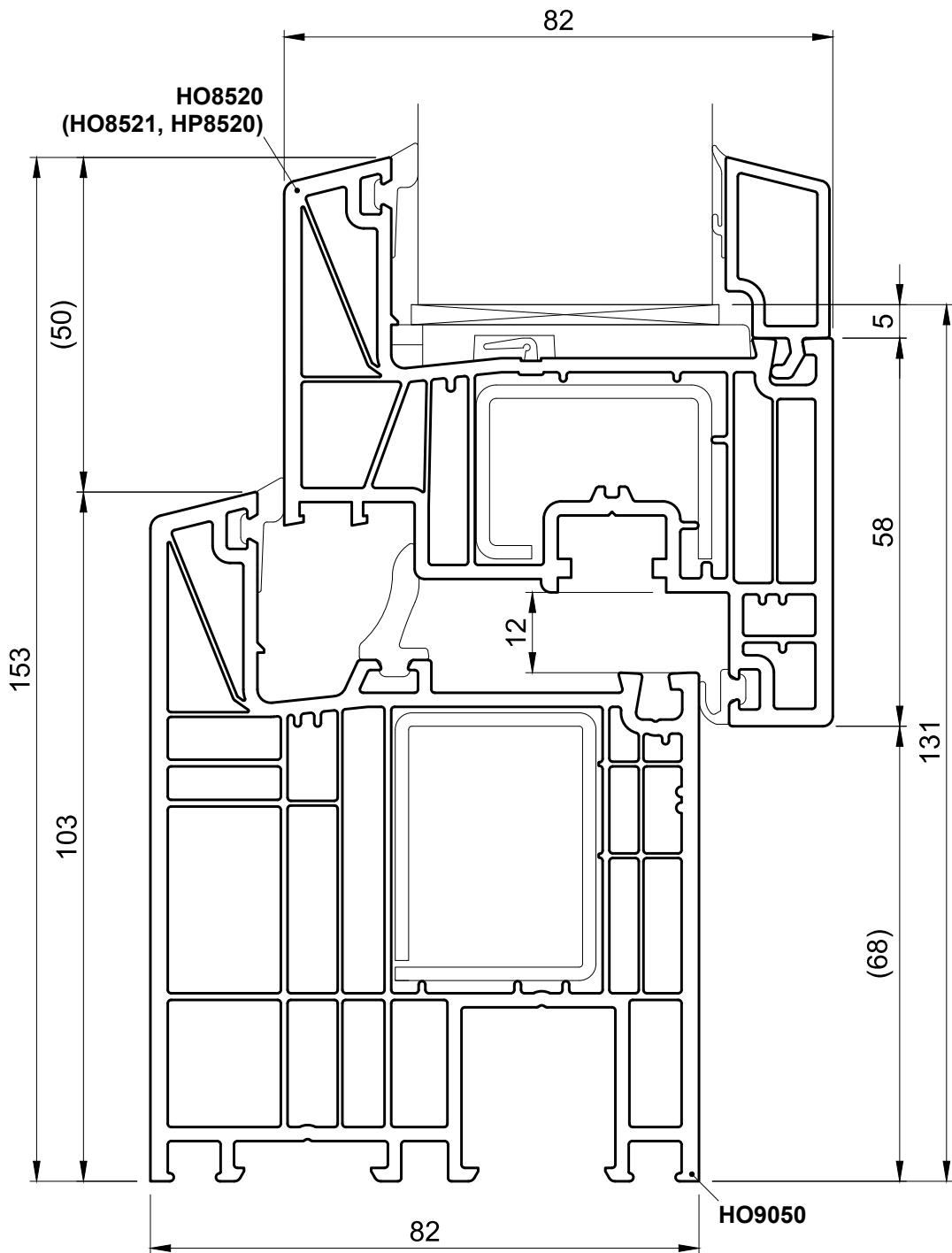

Sash  
HO8520 (HO8521)

Old building frame  
HO9110

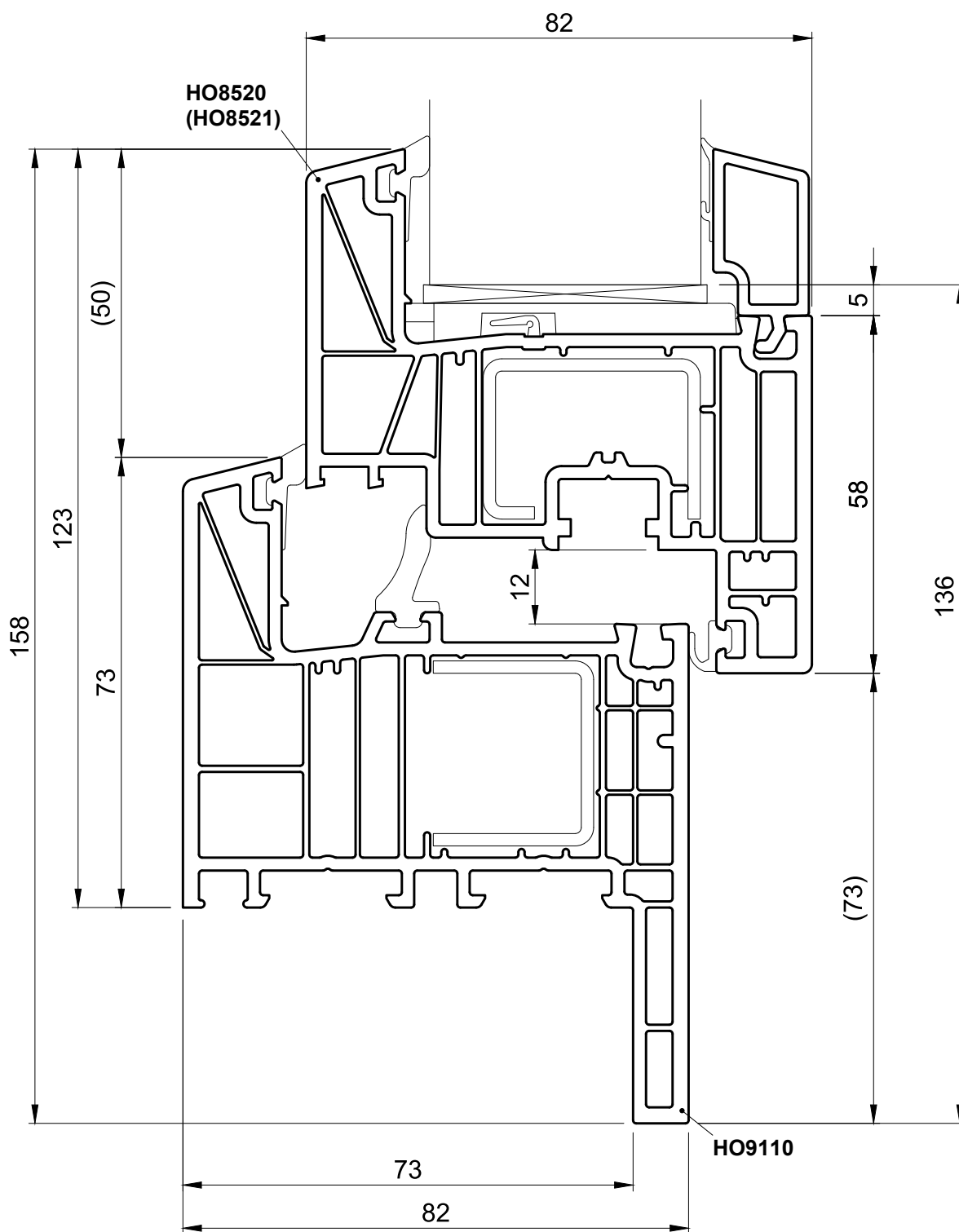

Sash  
HO8520 (HO8521)

Old building frame  
HO9120

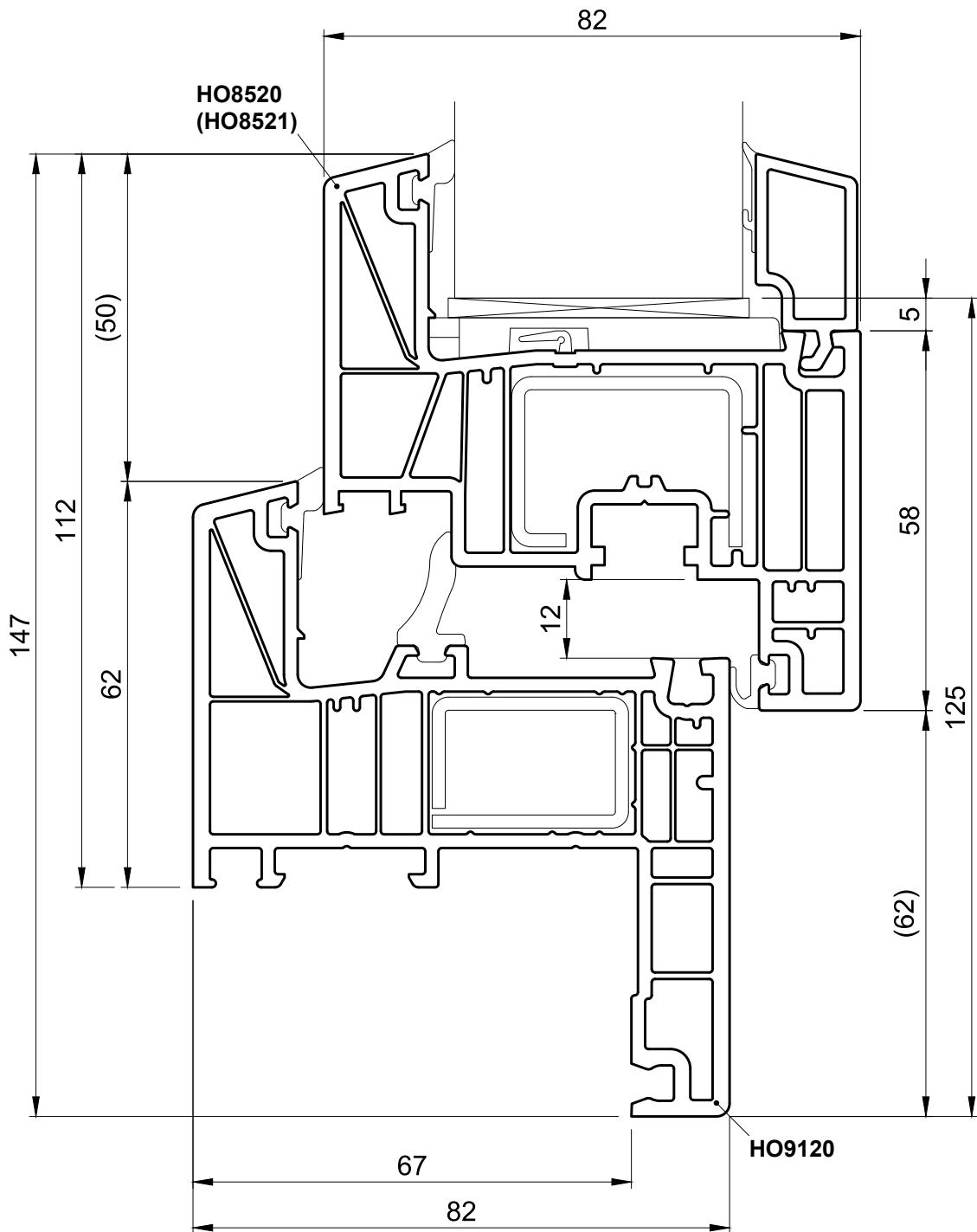

Sash  
HO8520 (HO8521)

Old building frame  
HO9100

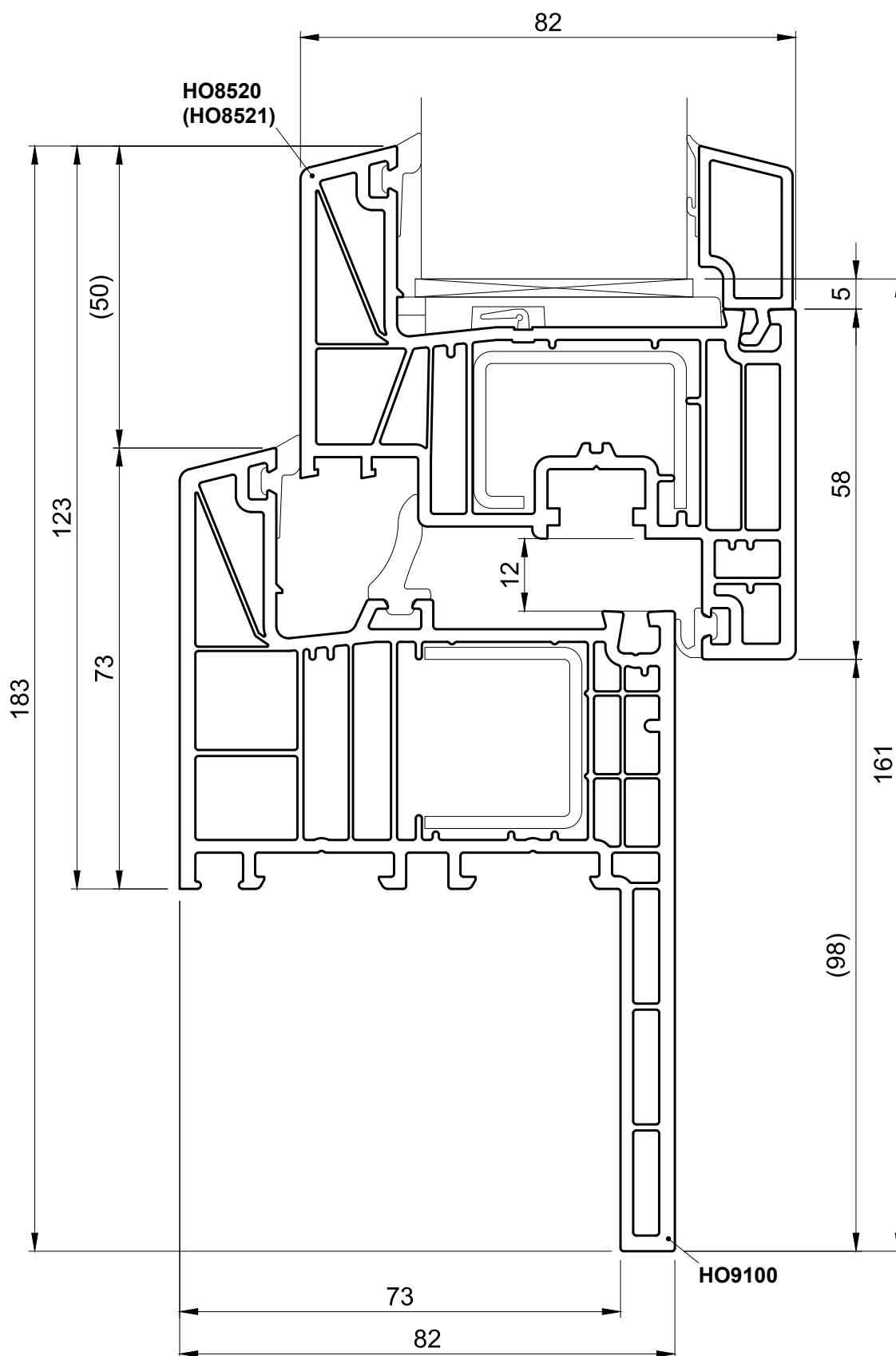

Sash  
HP8920

Frame  
HP9220

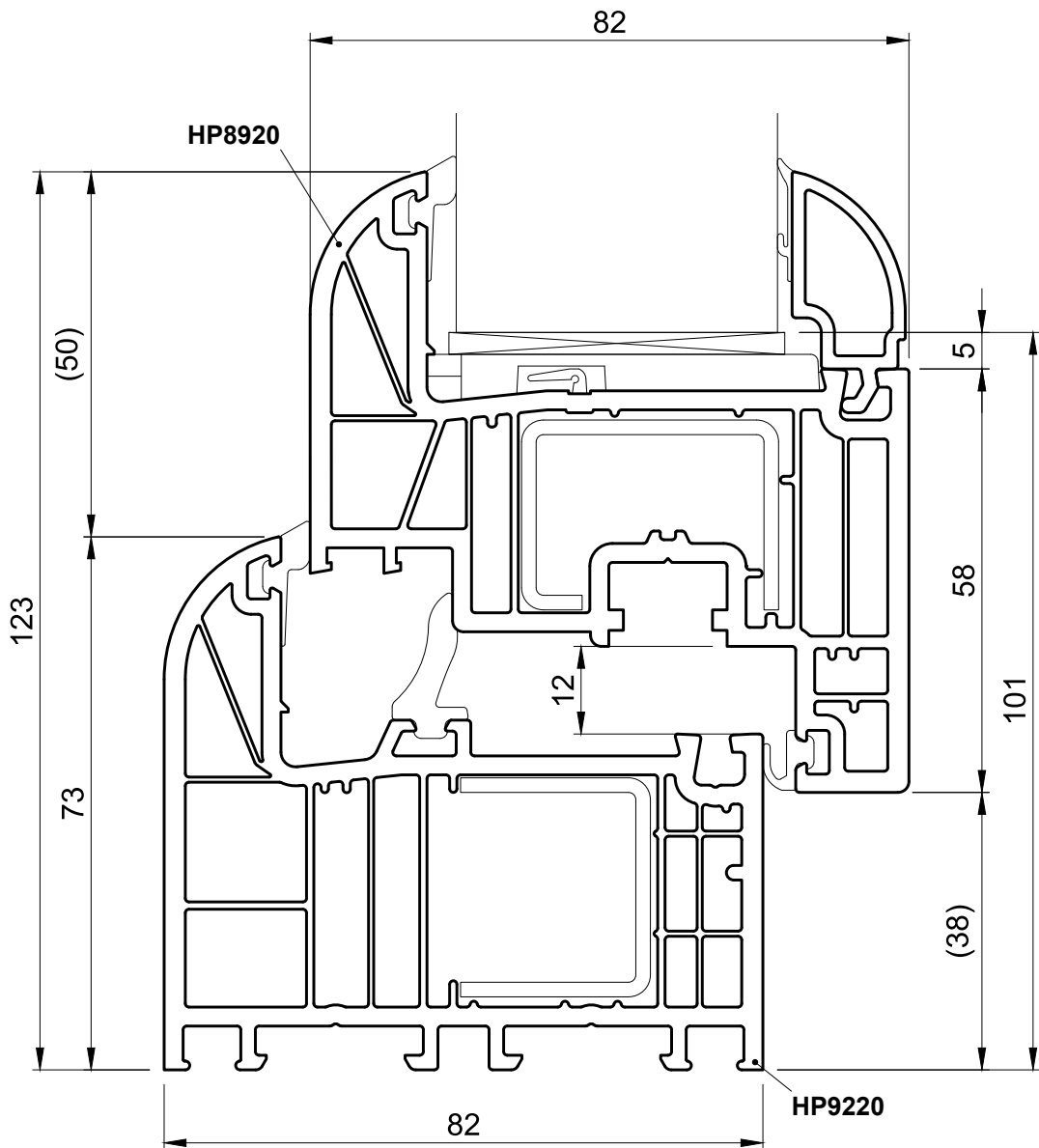

Sash  
HP8920

Frame  
HO9030

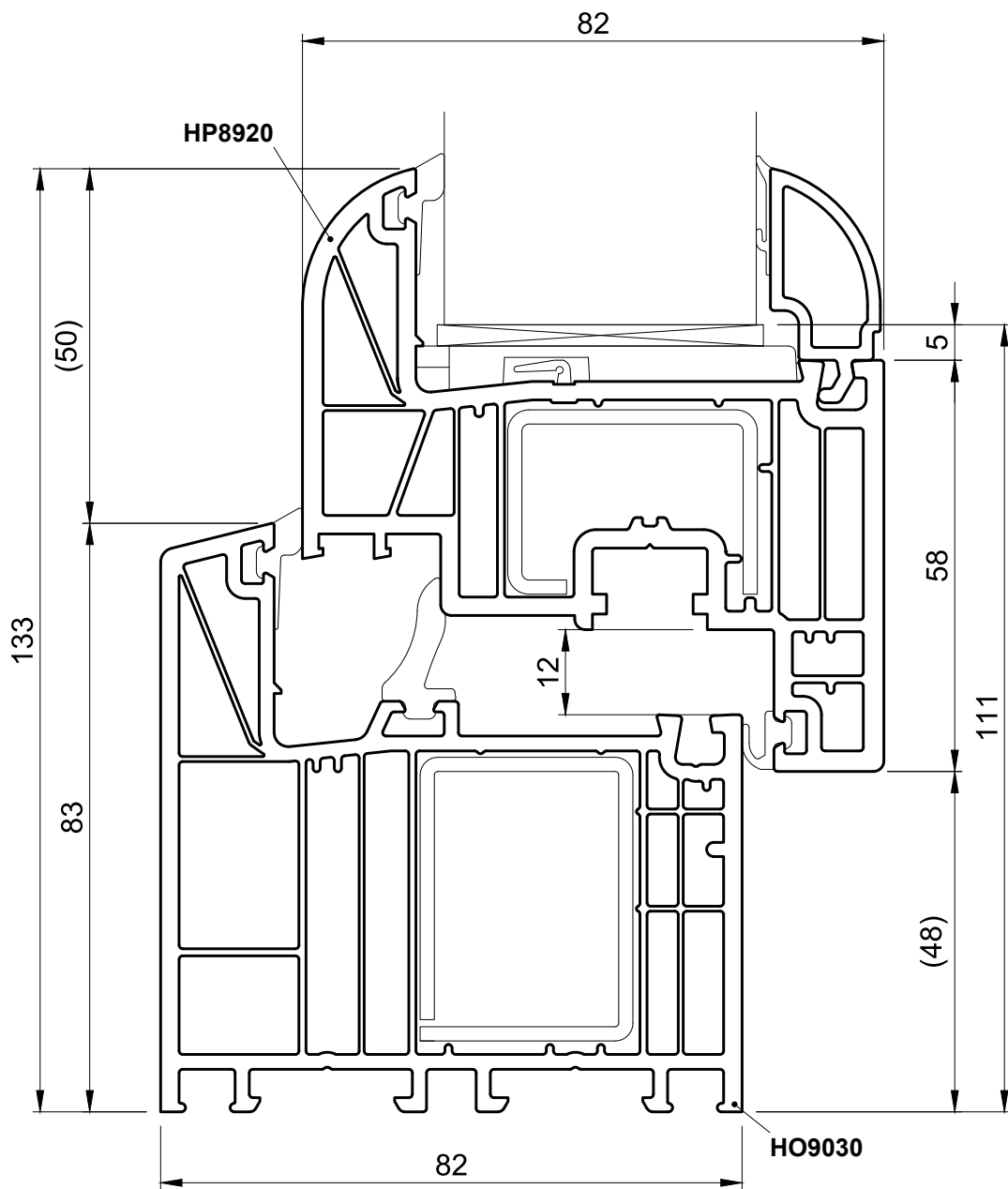

Sash  
**HP8920**

Frame  
**HO8030**

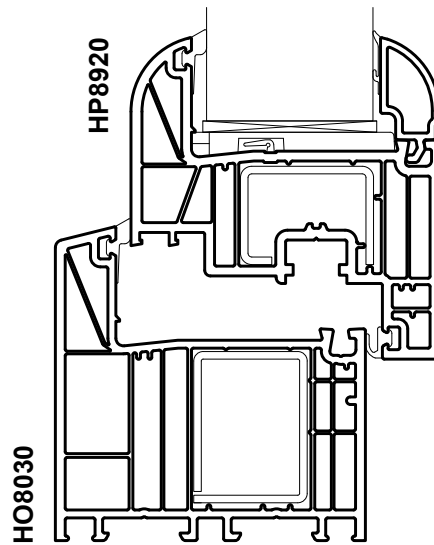

Sash  
HP8920

Frame  
HO9050

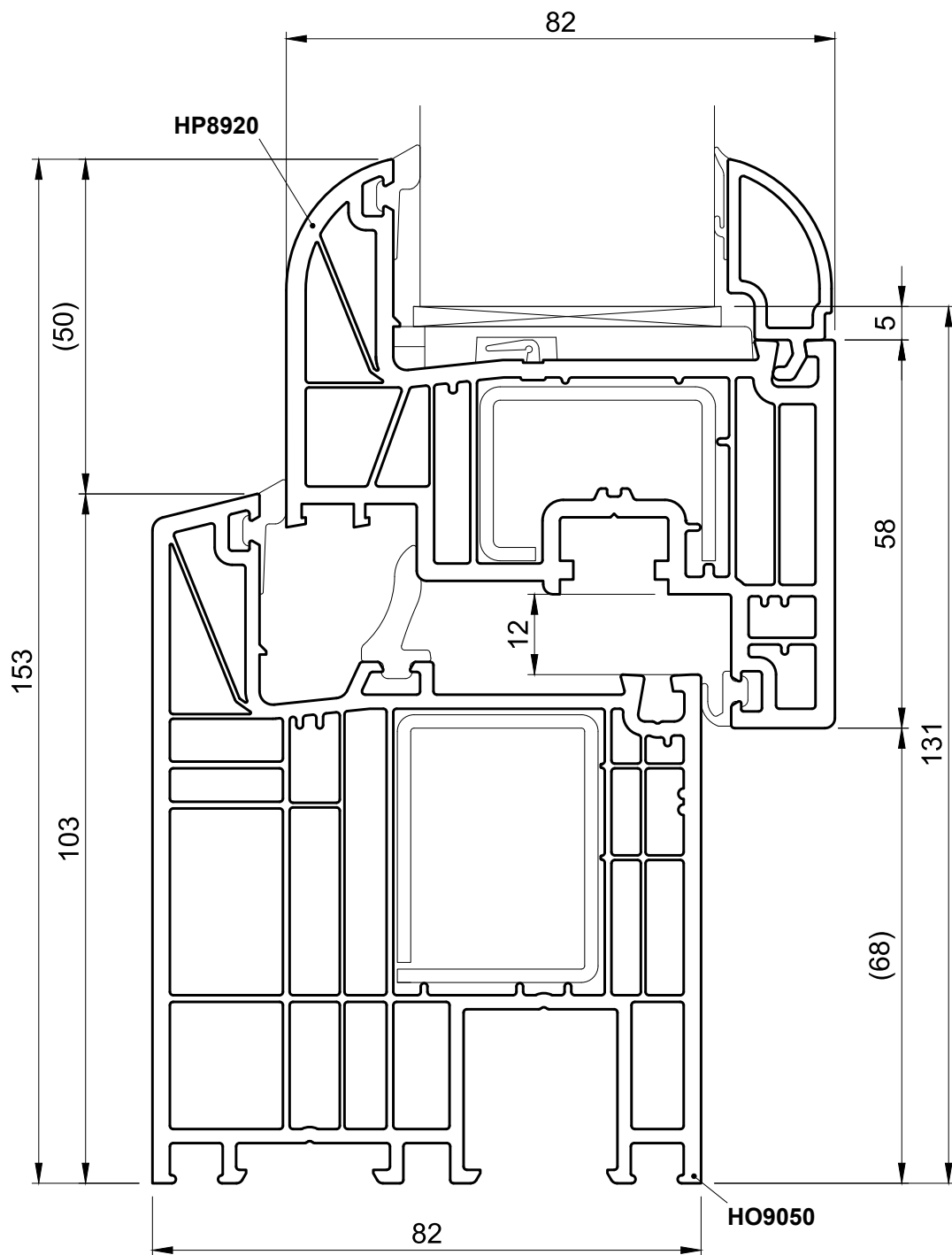

Sash  
HP8920

Old building frame  
HO9110

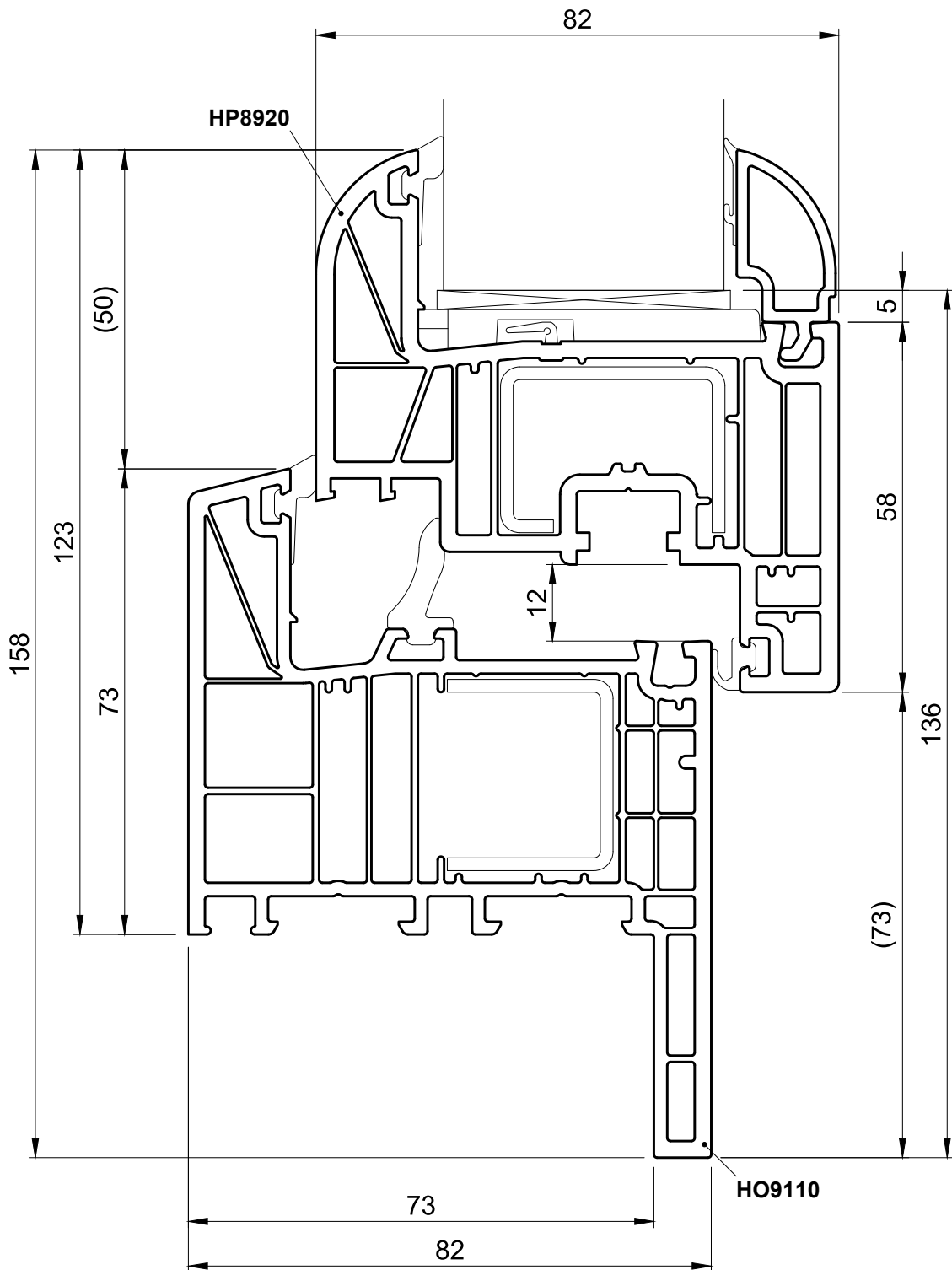

Sash  
HP8920

Old building frame  
HO9120

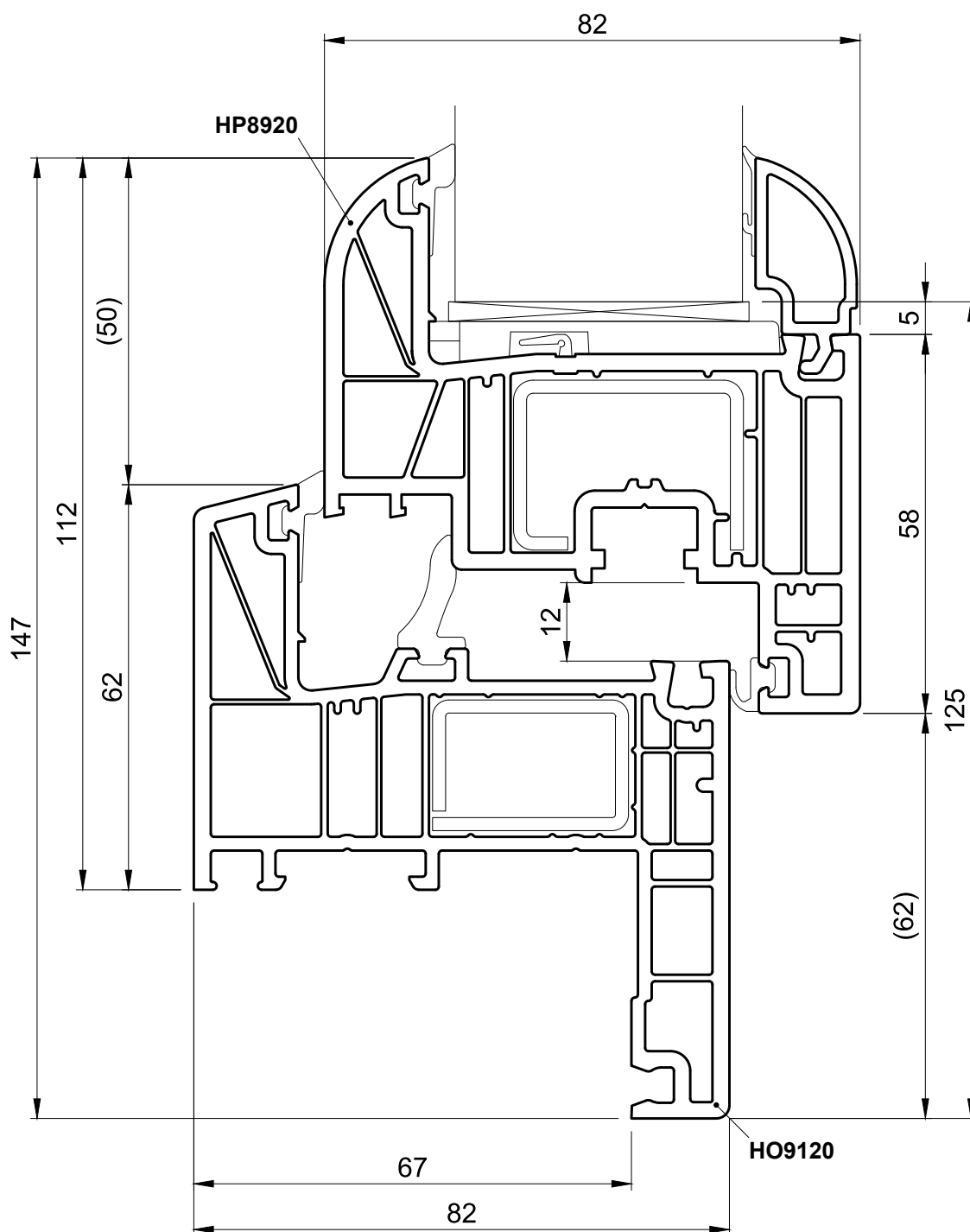

Sash  
HP8920

Old building frame  
HO9100

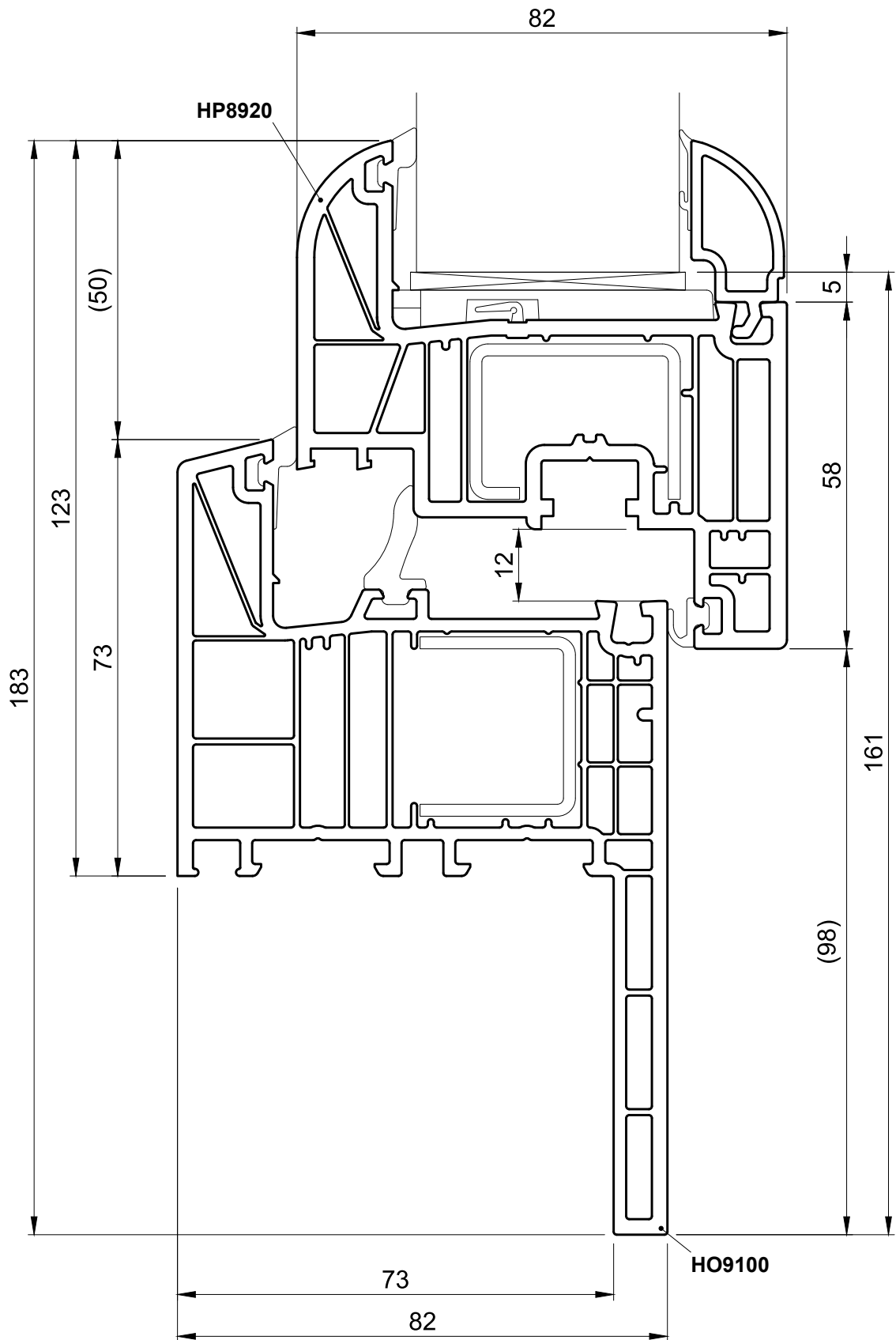

Sash  
HO8530

Frame  
HO9020

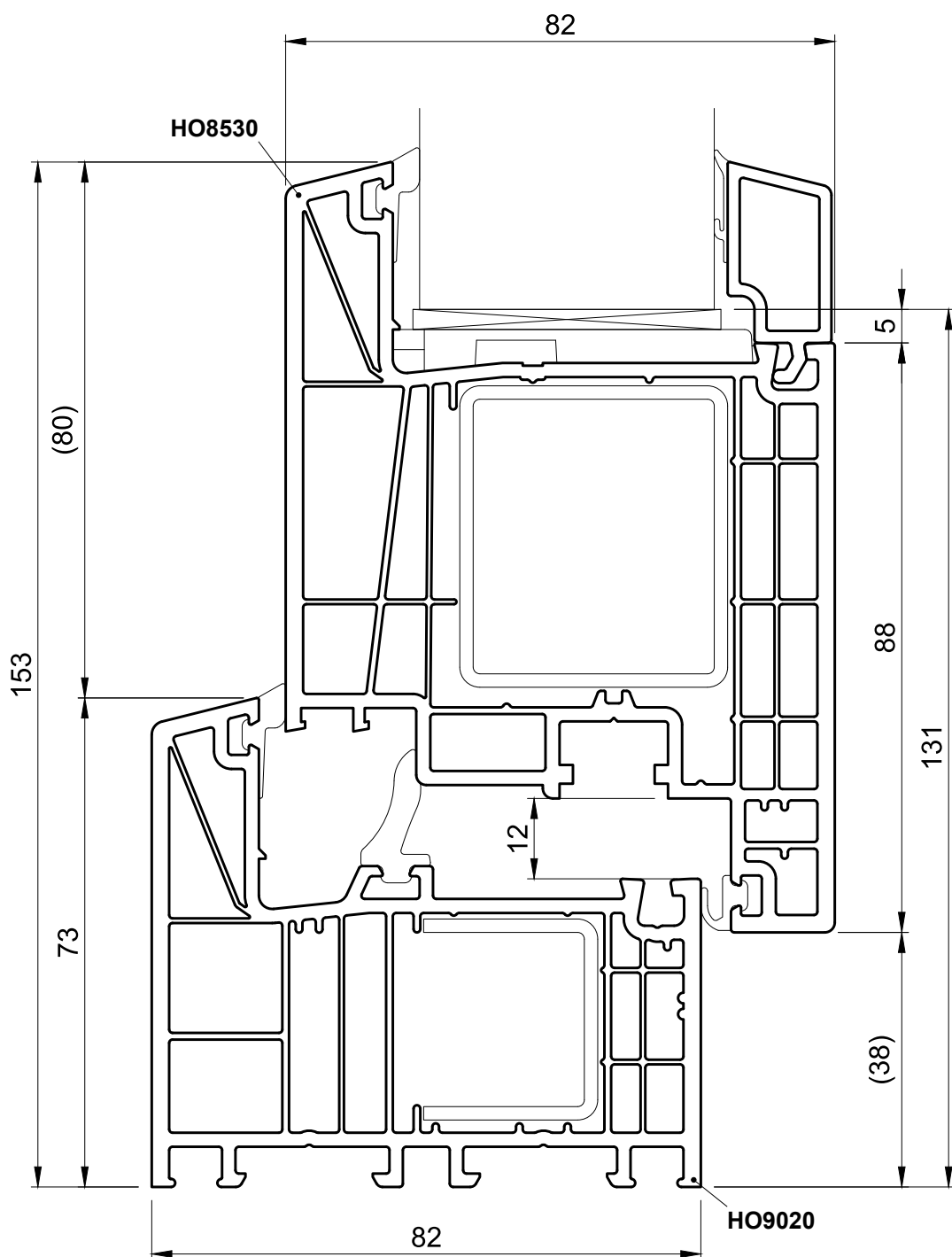

Sash  
**HO8530**

Frame  
**HO8020**

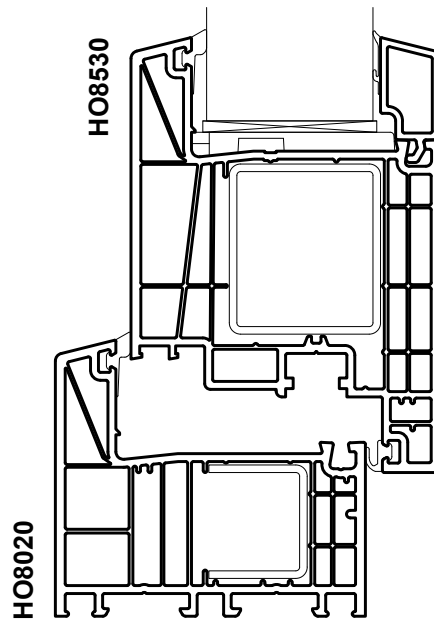

Sash  
HO8530

Frame  
HO9030

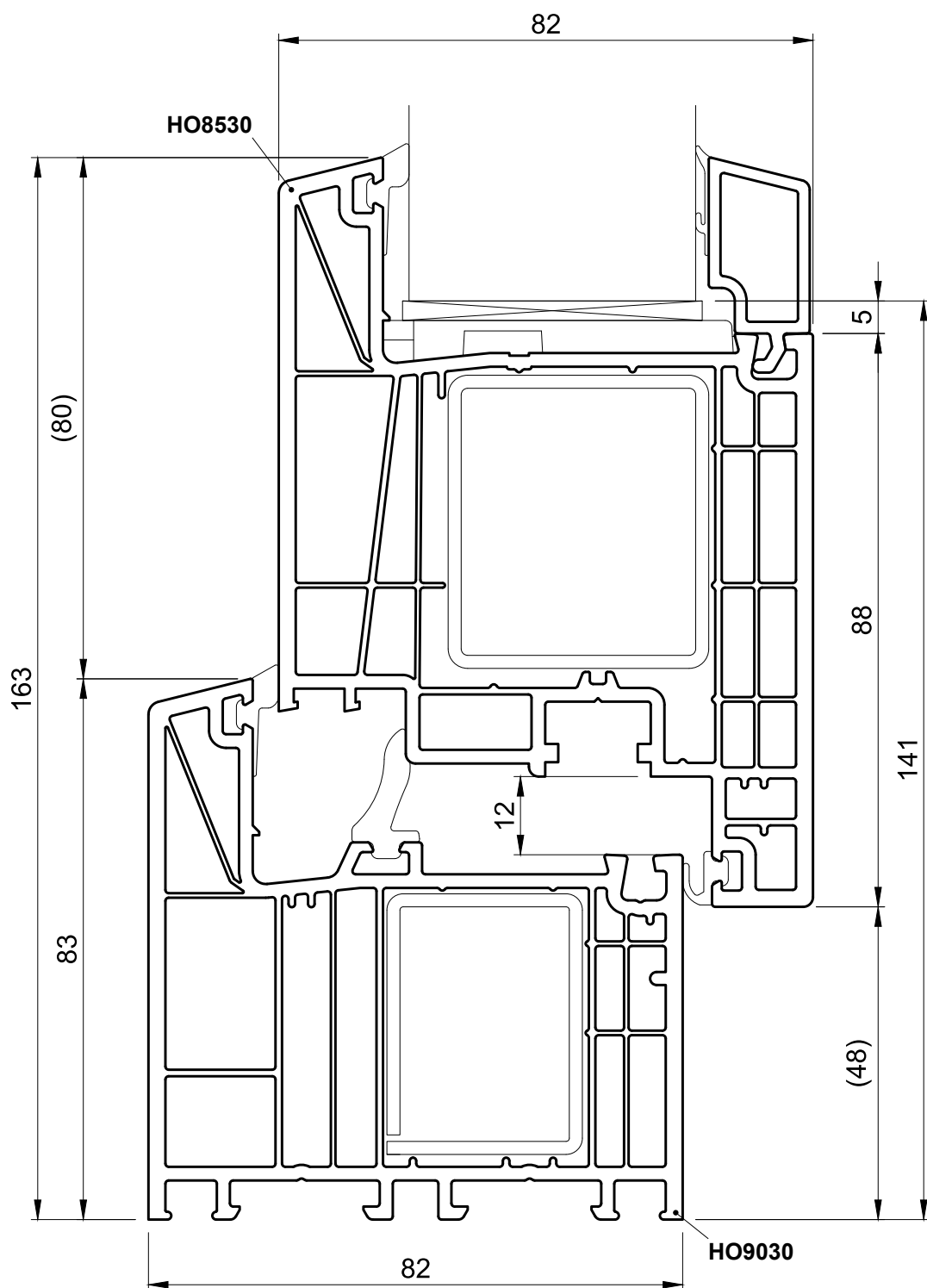

Sash  
**HO8530**

Frame  
**HO8030**

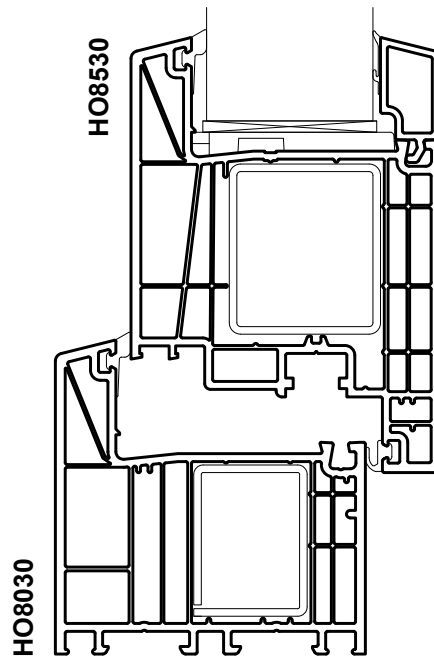

Sash  
HO8530

Frame  
HO9050

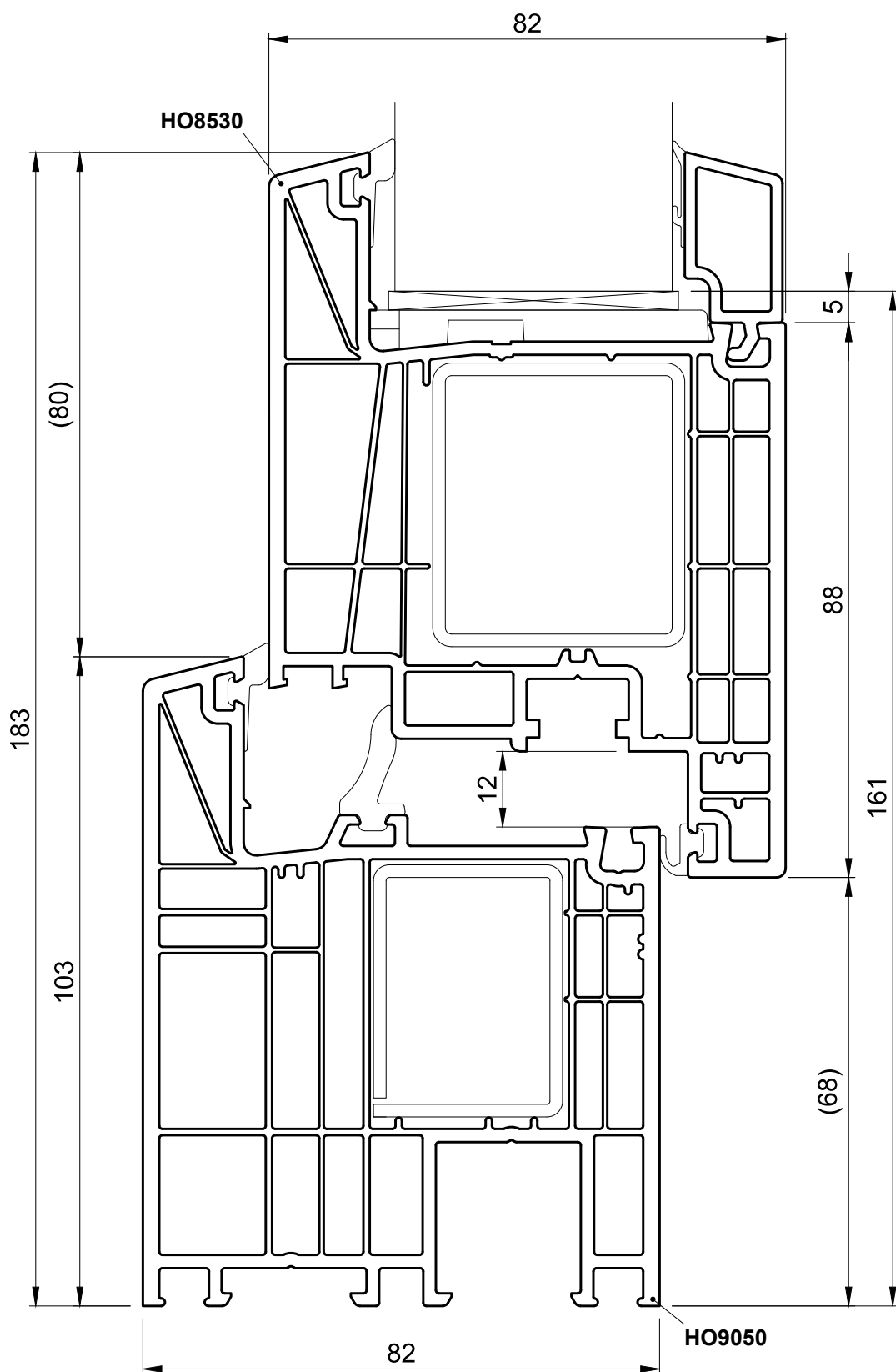

Sash  
HO8530

Old building frame  
HO9110

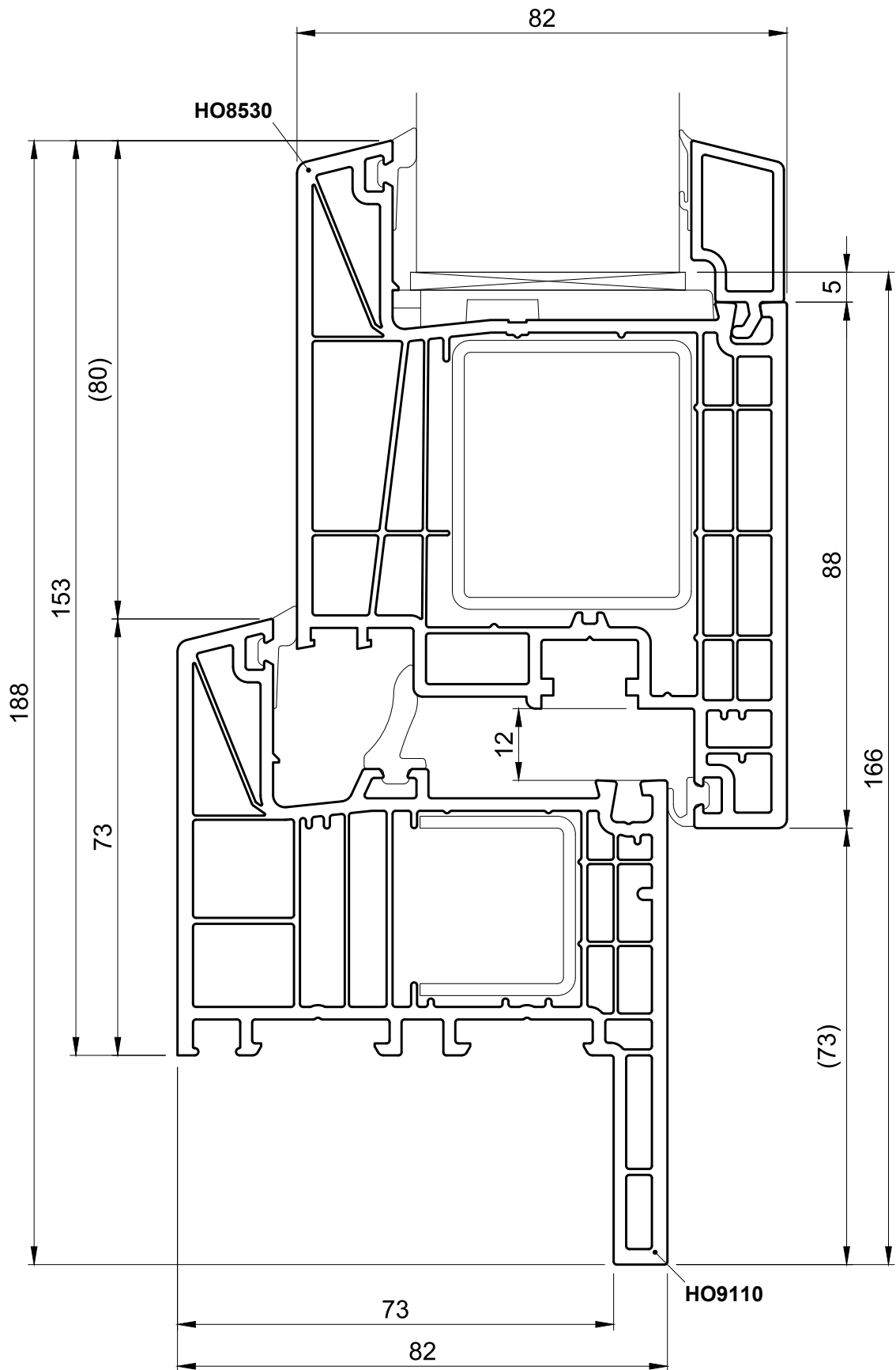

Sash  
HO8530

Old building frame  
HO9120

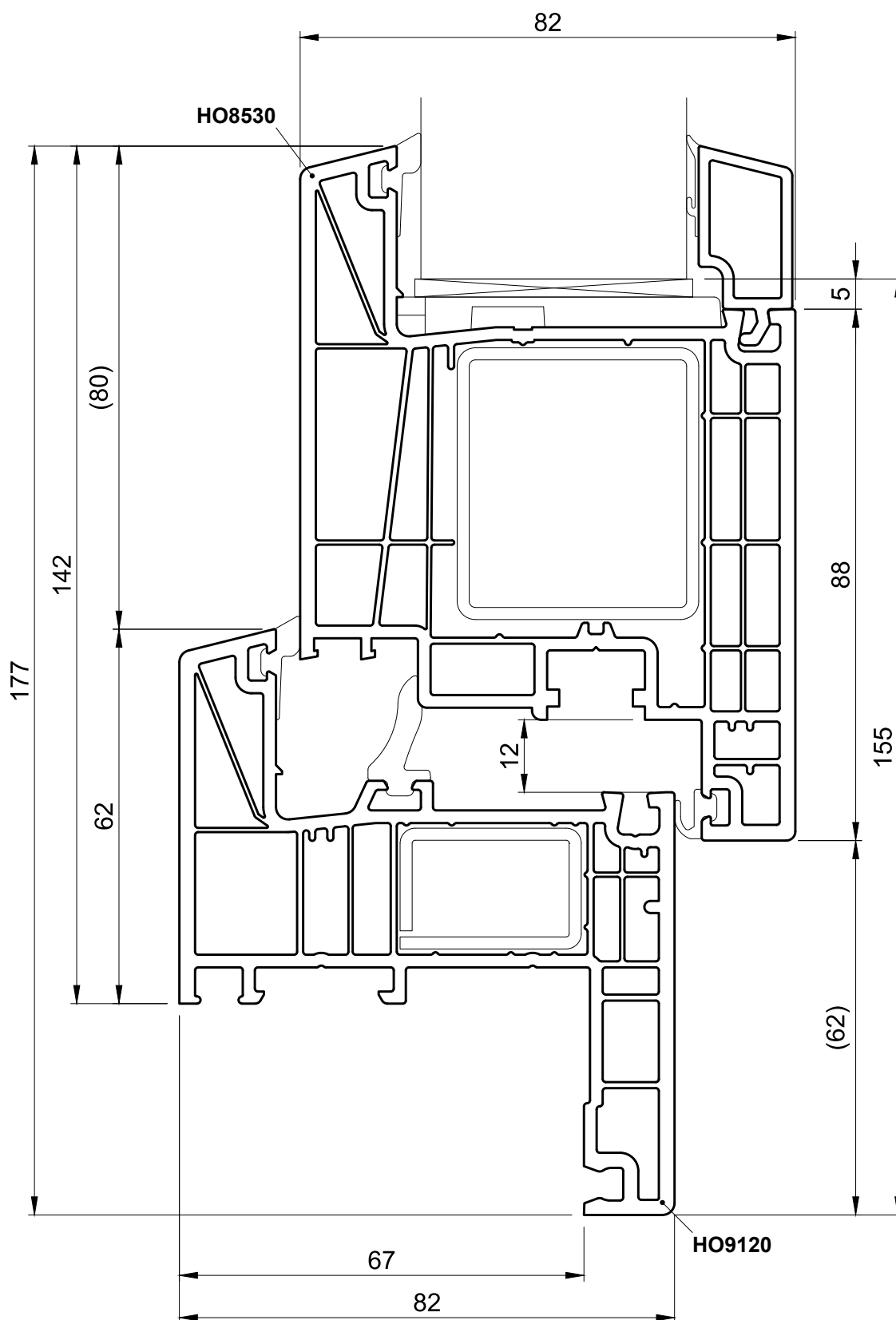

Sash  
HO8530

Old building frame  
HO9100

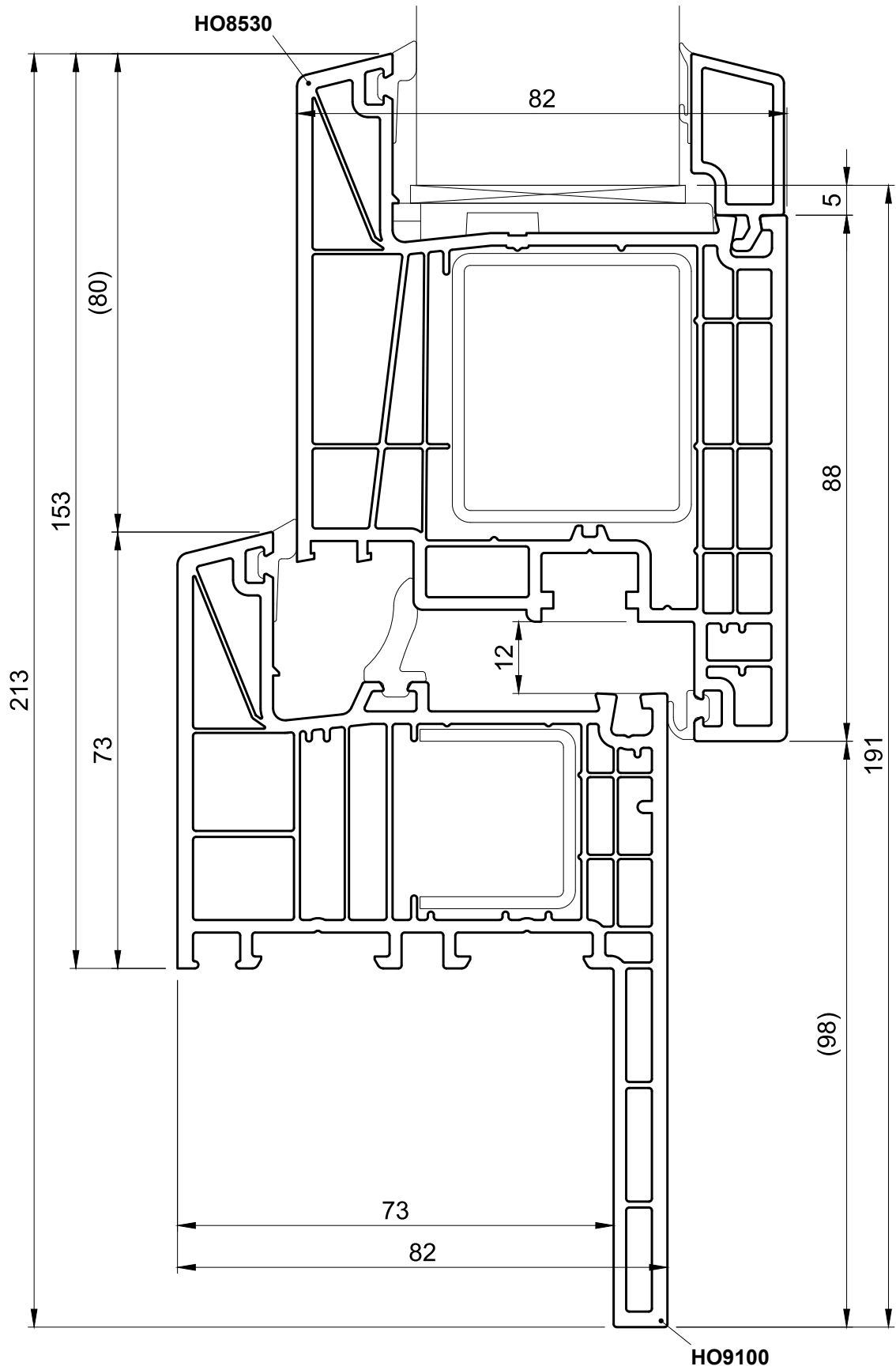

Sash  
HP8930

Frame  
HP9220

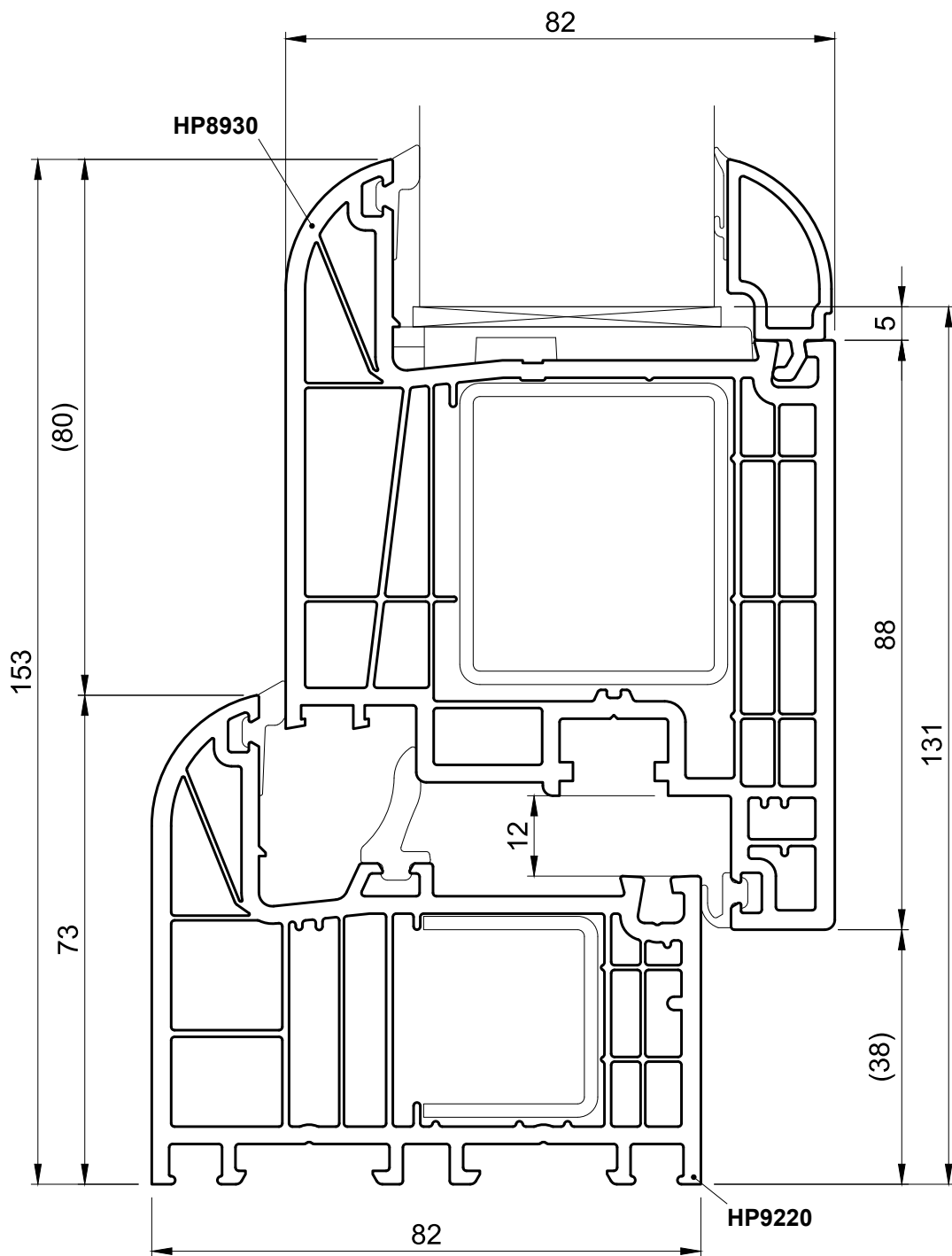

Sash  
HP8930

Frame  
HO9030

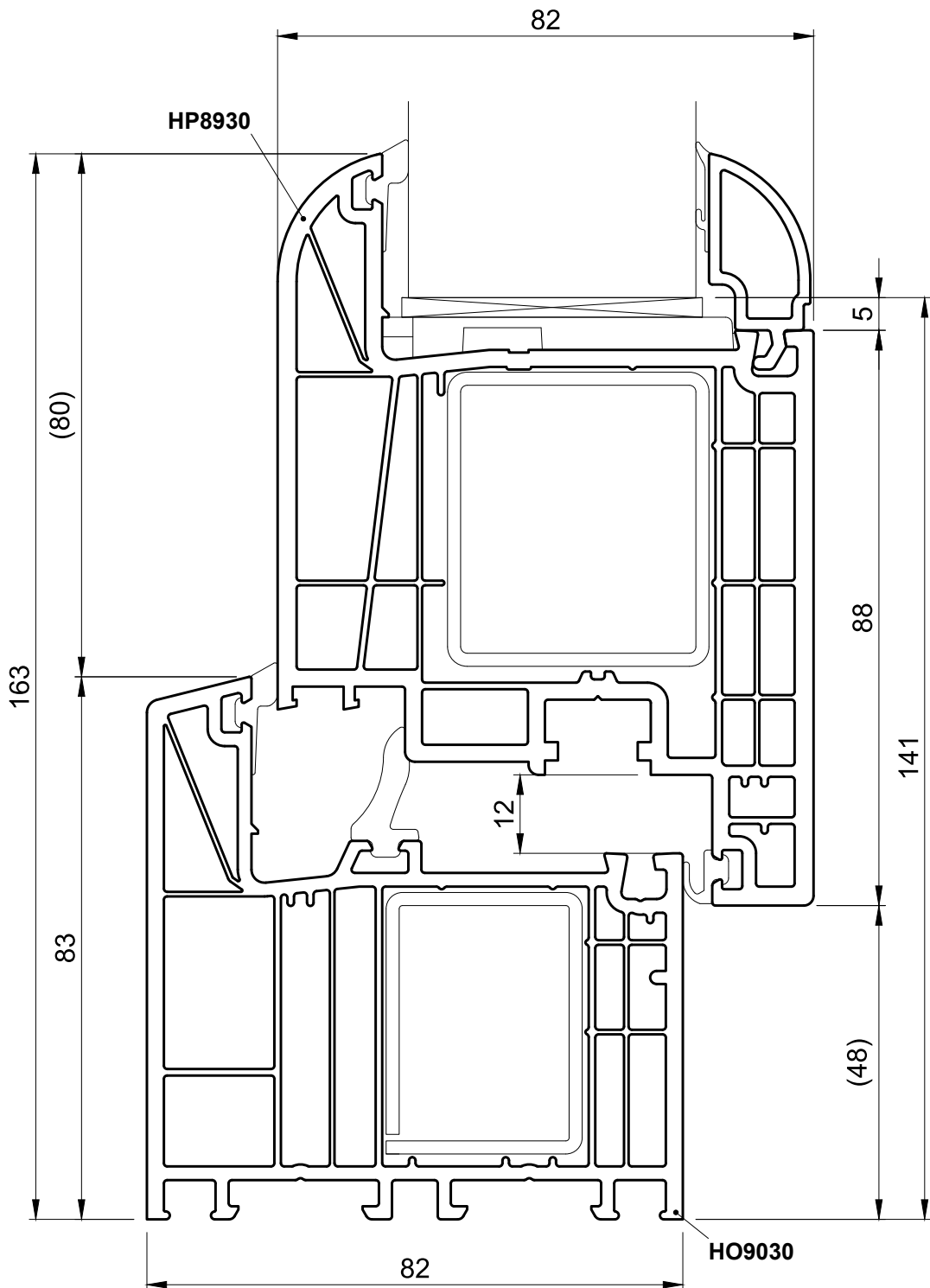

Sash  
HP8930

Frame  
HO8030

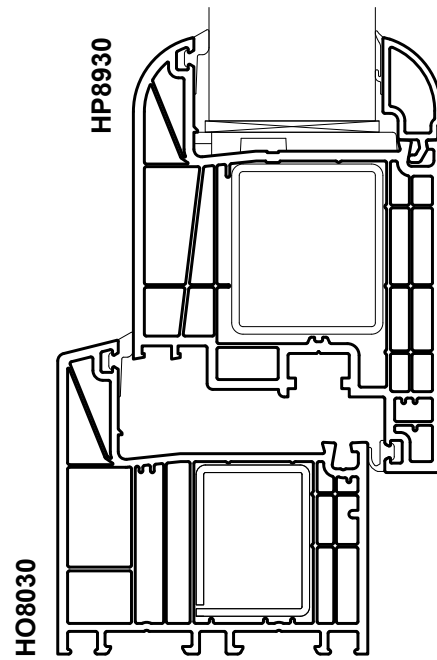

Sash  
HP8930

Frame  
HO9050

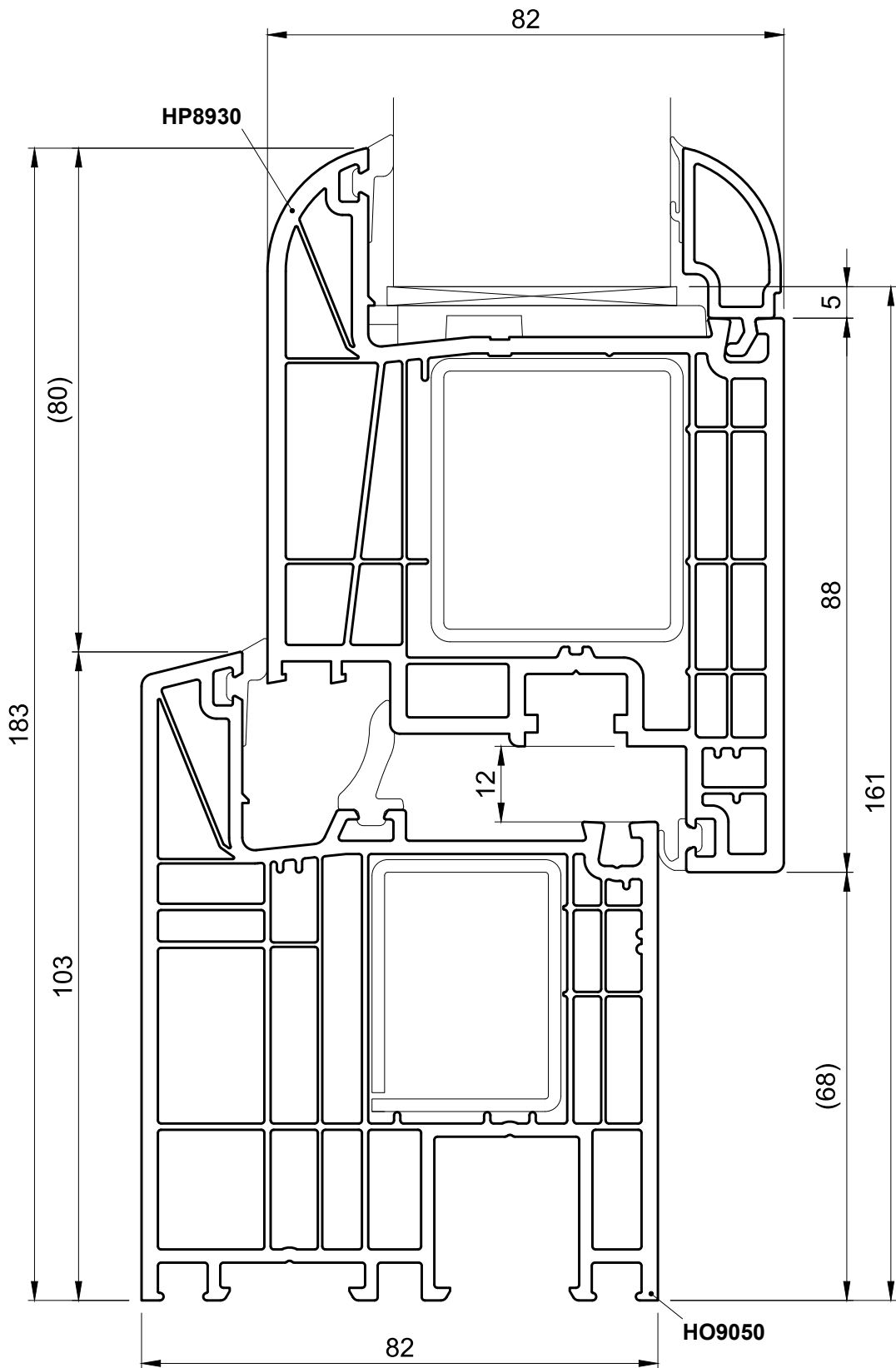

Sash  
HP8930

Old building frame  
HO9110

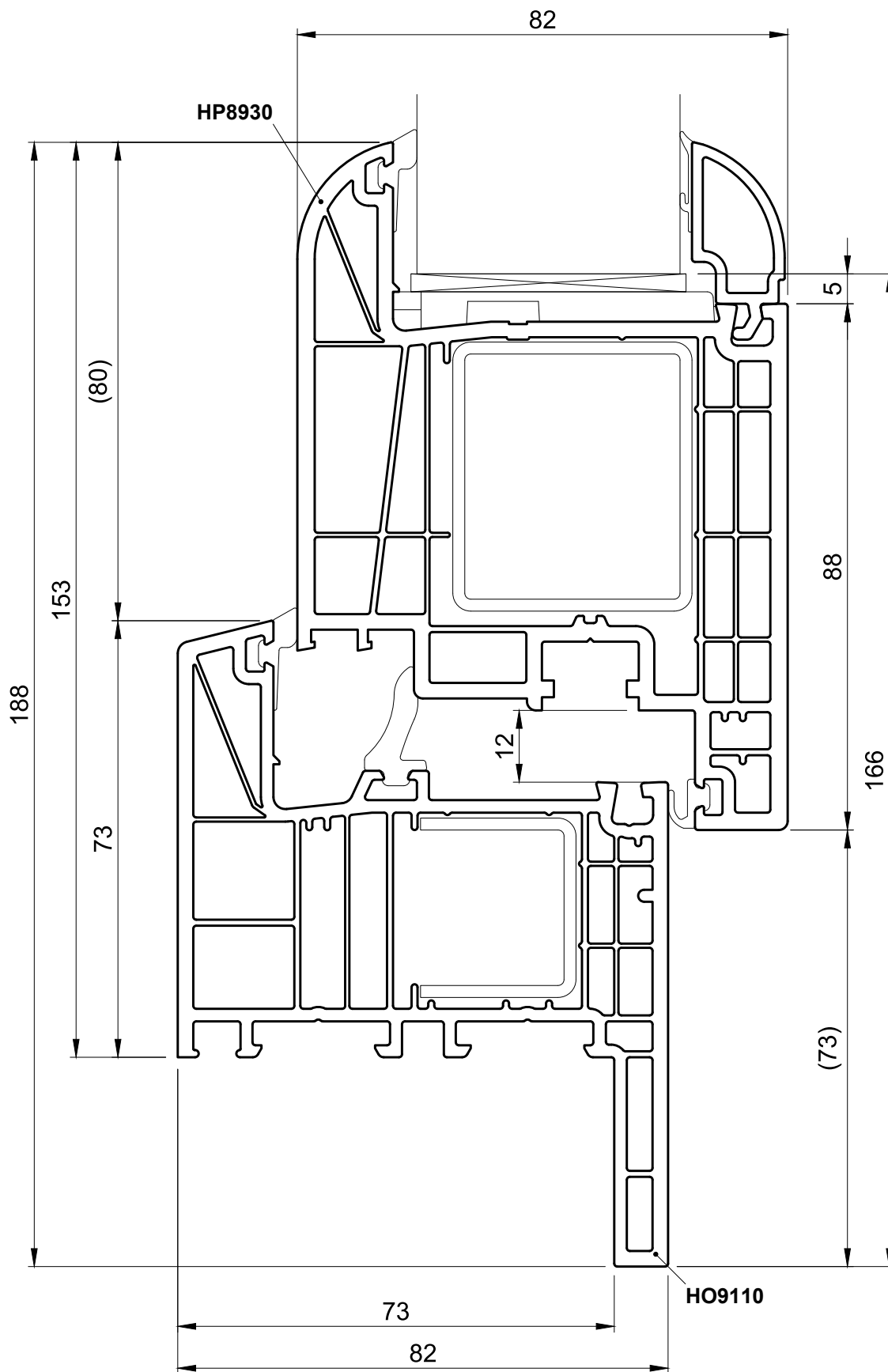

Sash  
HP8930

Old building frame  
HO9120

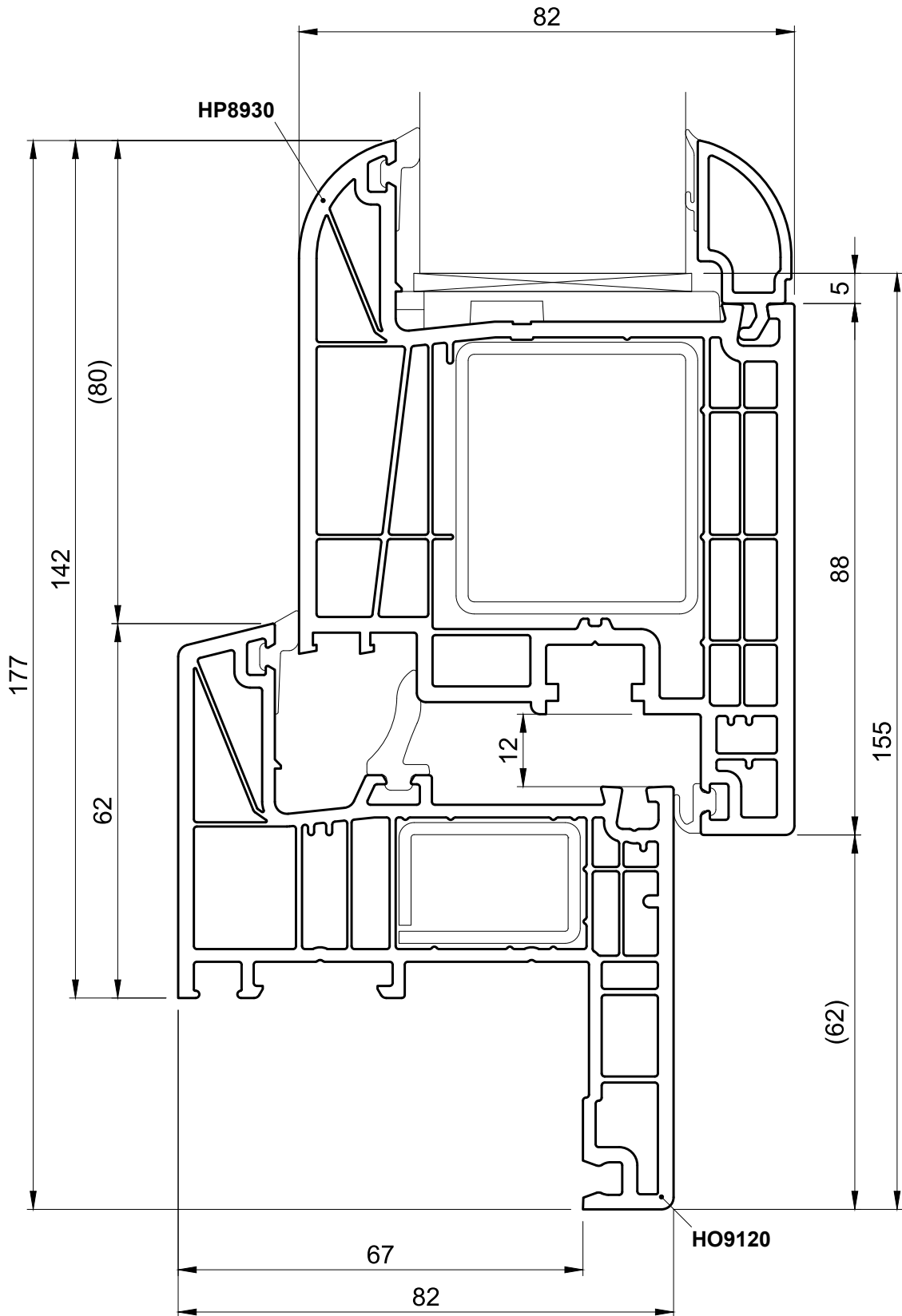

Sash  
HP8930

Old building frame  
HO9100

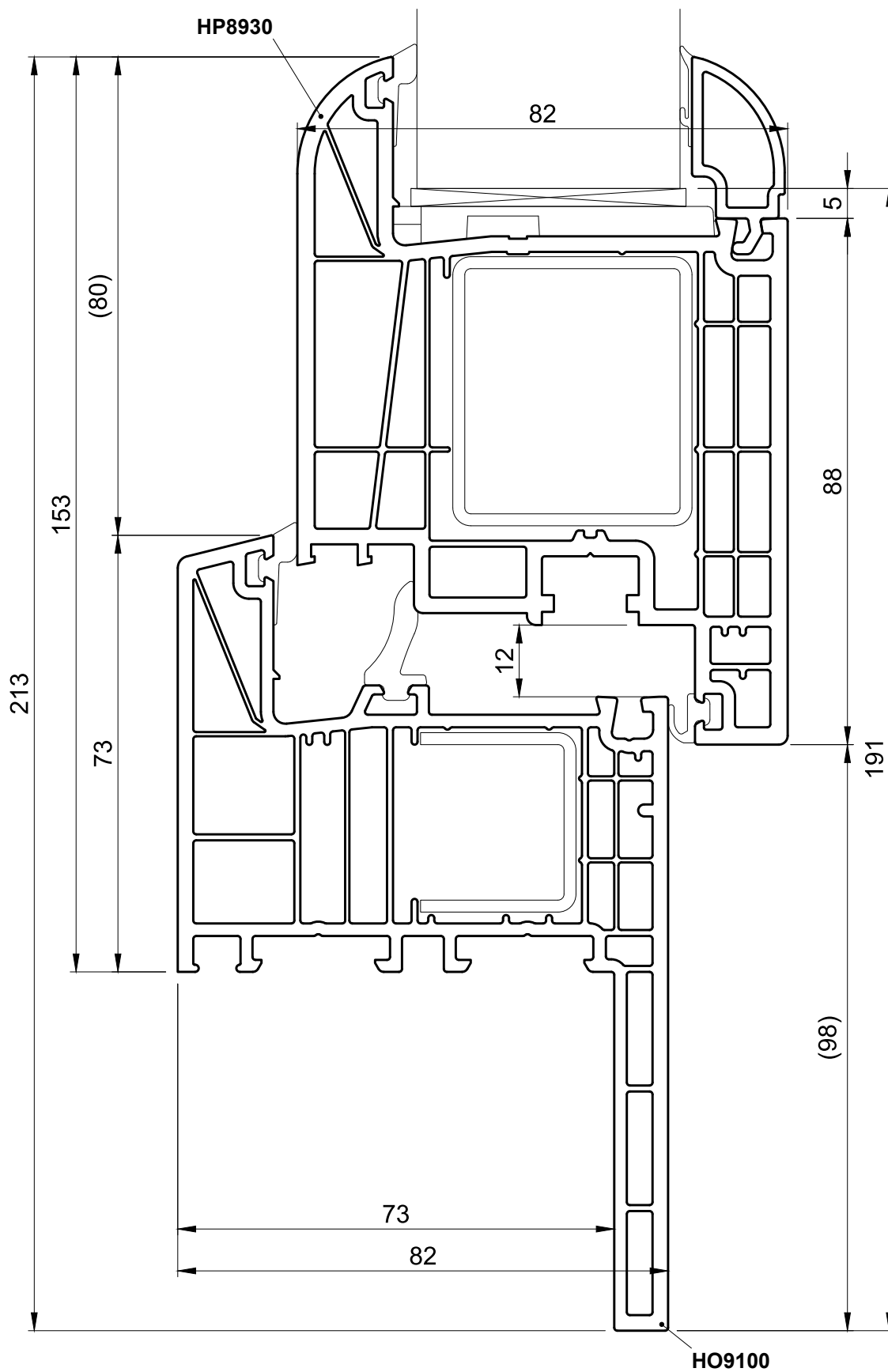

Sash  
HO8540

Frame  
HO9020

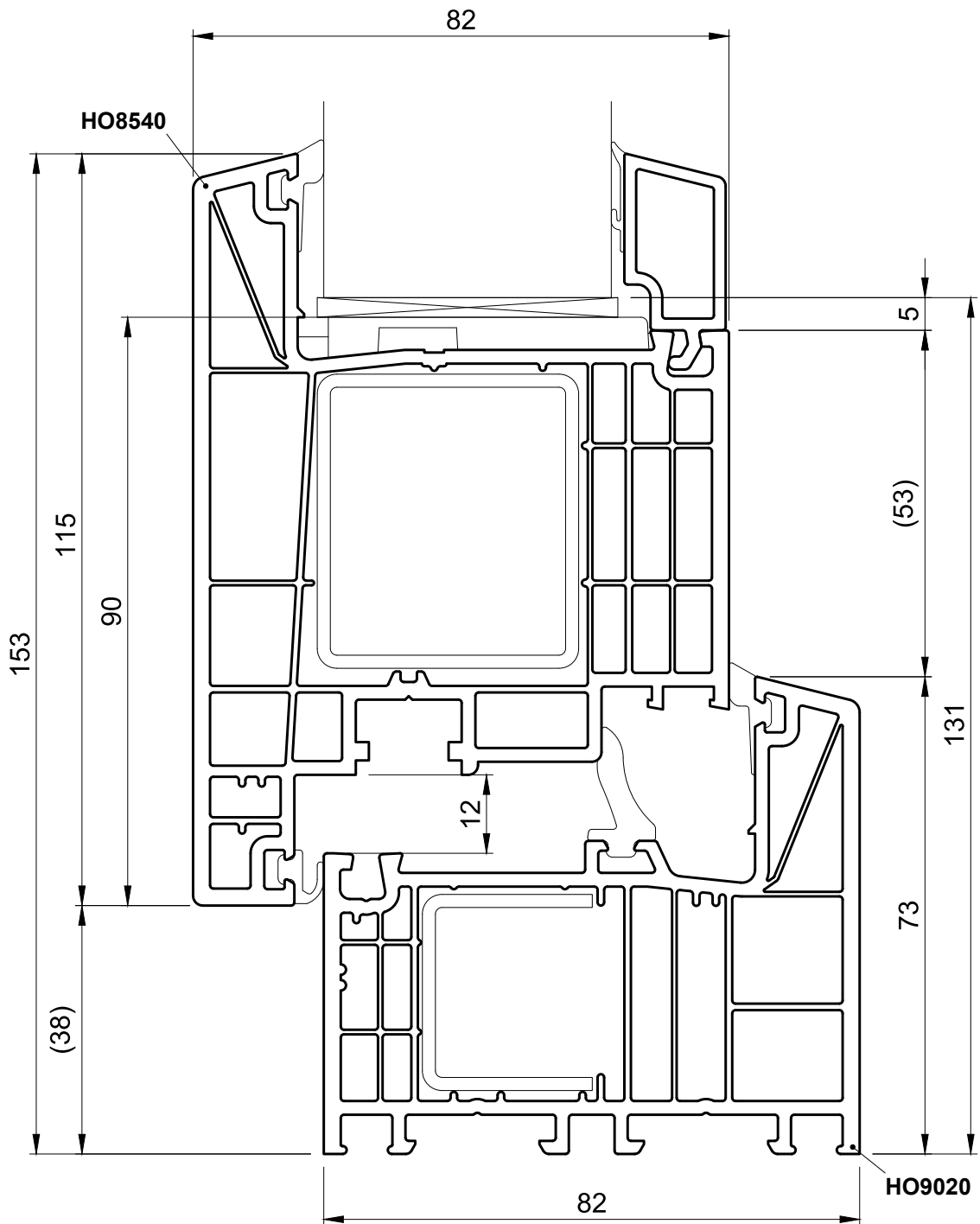

Sash  
HO8540

Frame  
HO8020

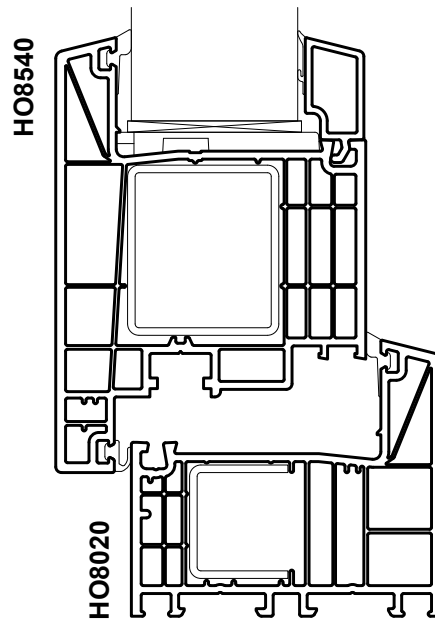

Sash  
HO8540

Frame  
HO9030

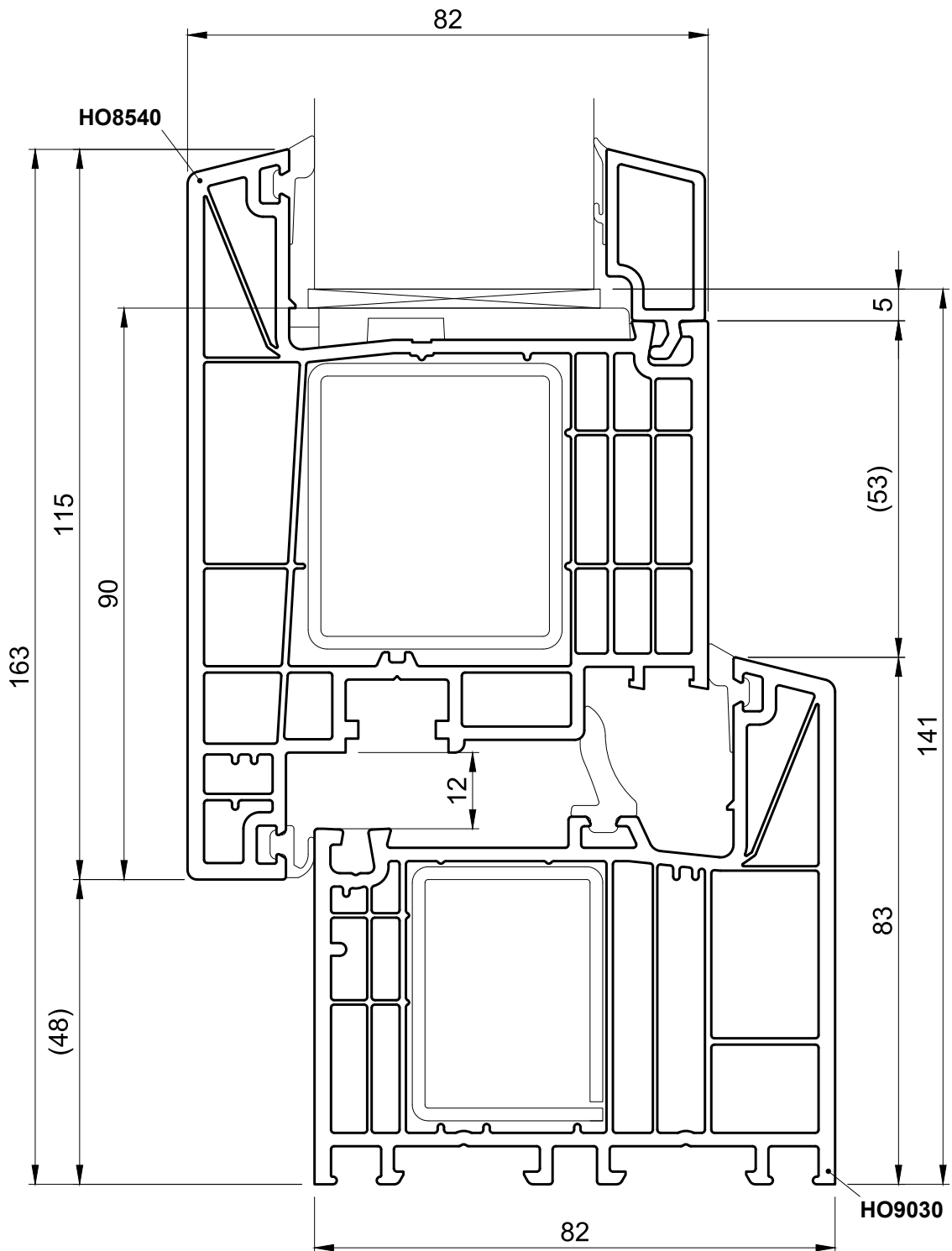

Sash  
HO8540

Frame  
HO8030

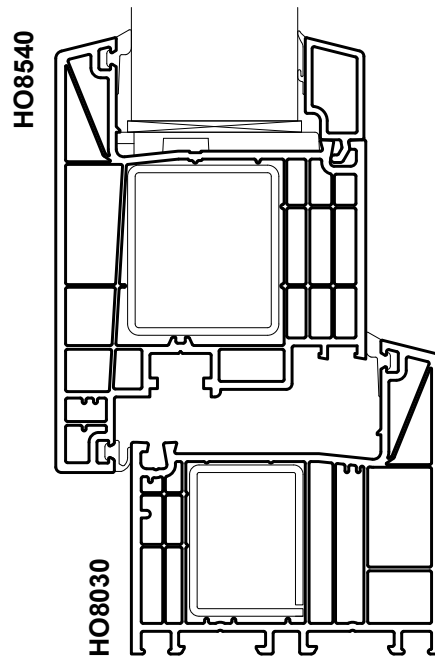

Sash  
HO8540

Frame  
HO9050

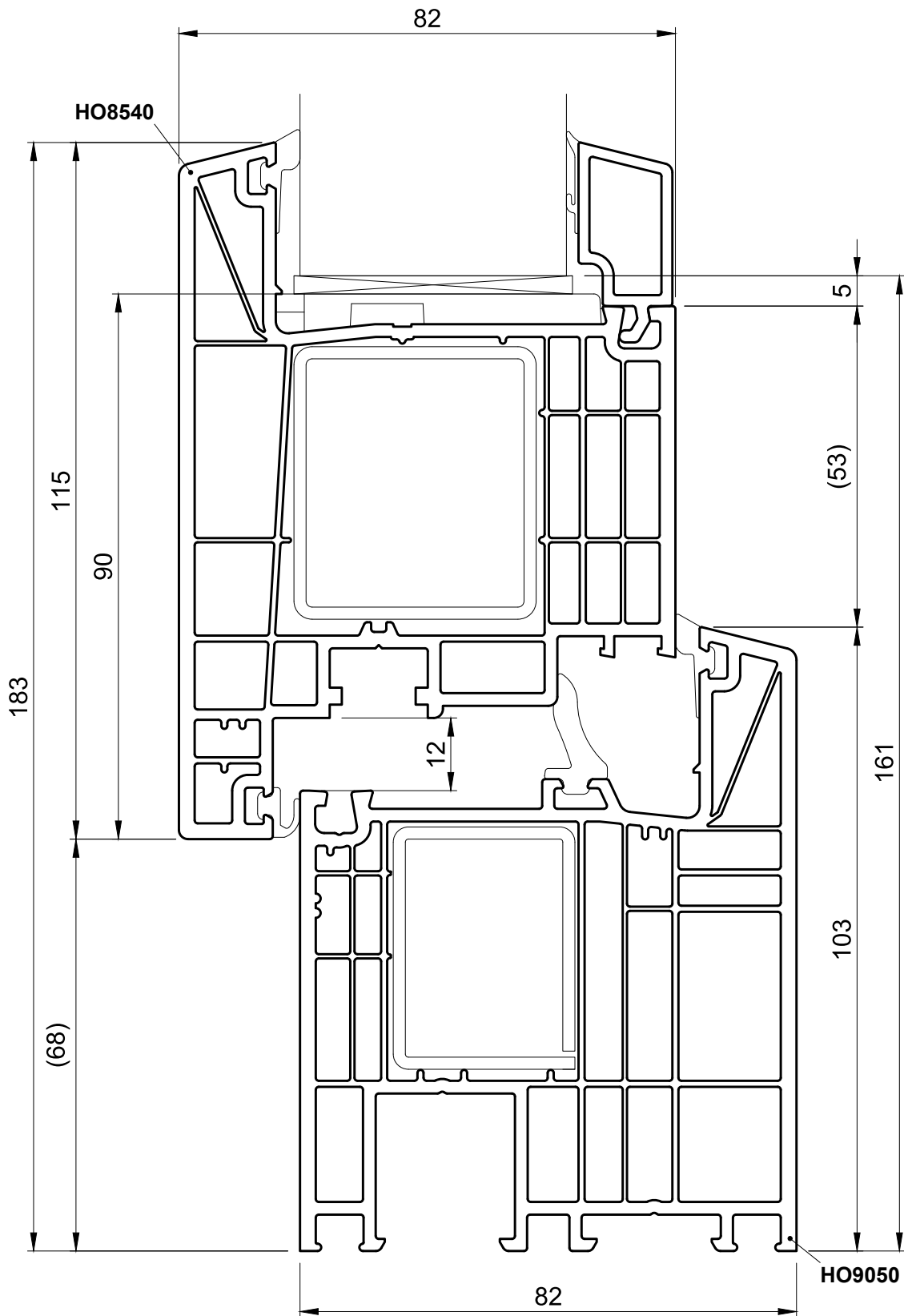

Sash  
HP8550

Frame  
HO9020

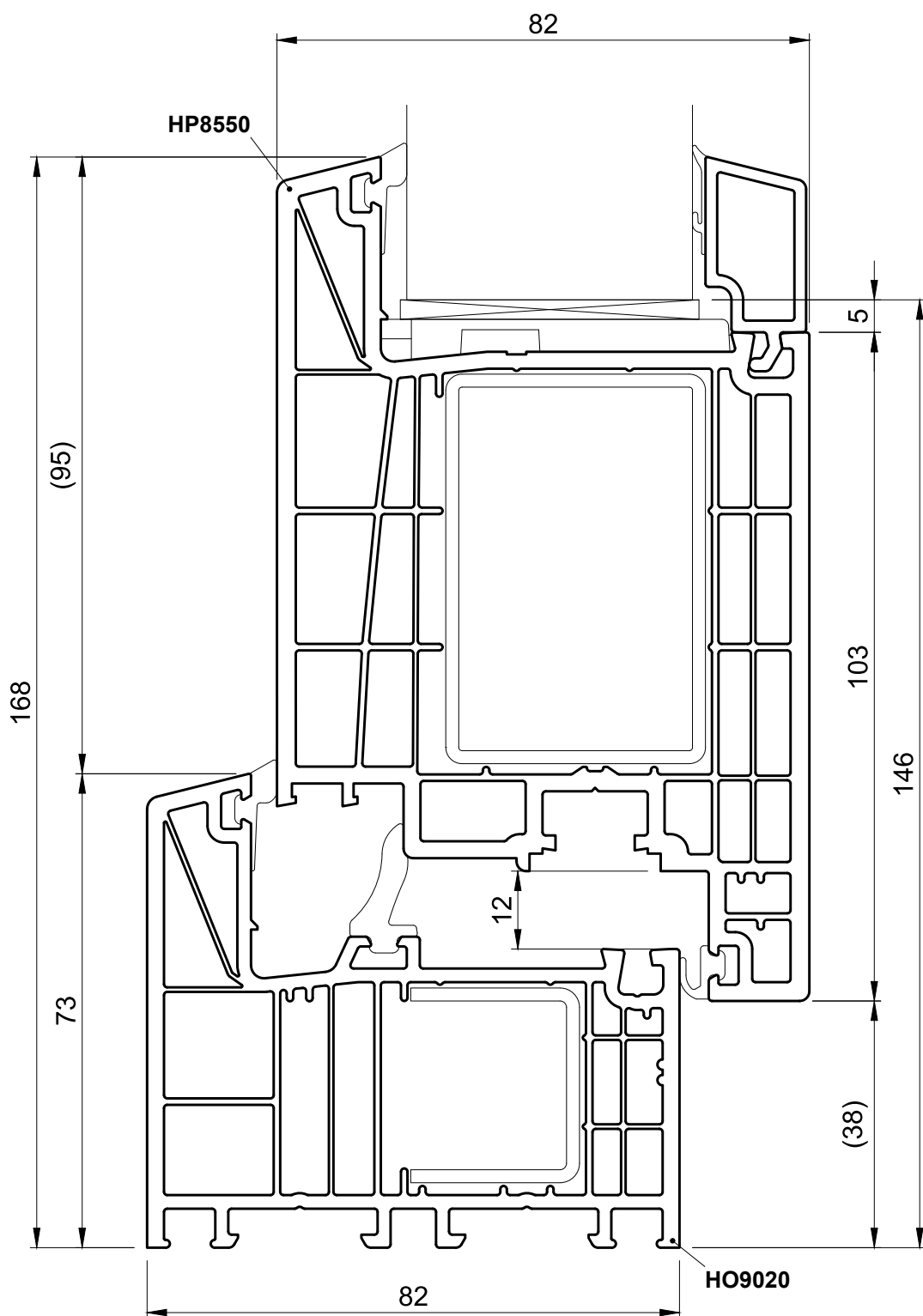

Sash  
**HP8550**

Frame  
**HO8020**

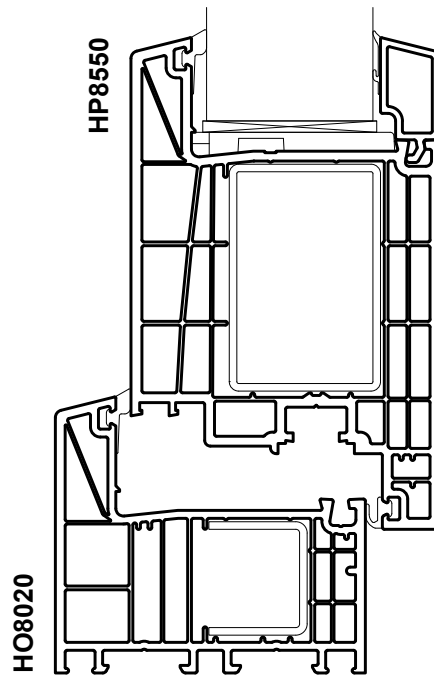

Sash  
HP8550

Frame  
HO9030

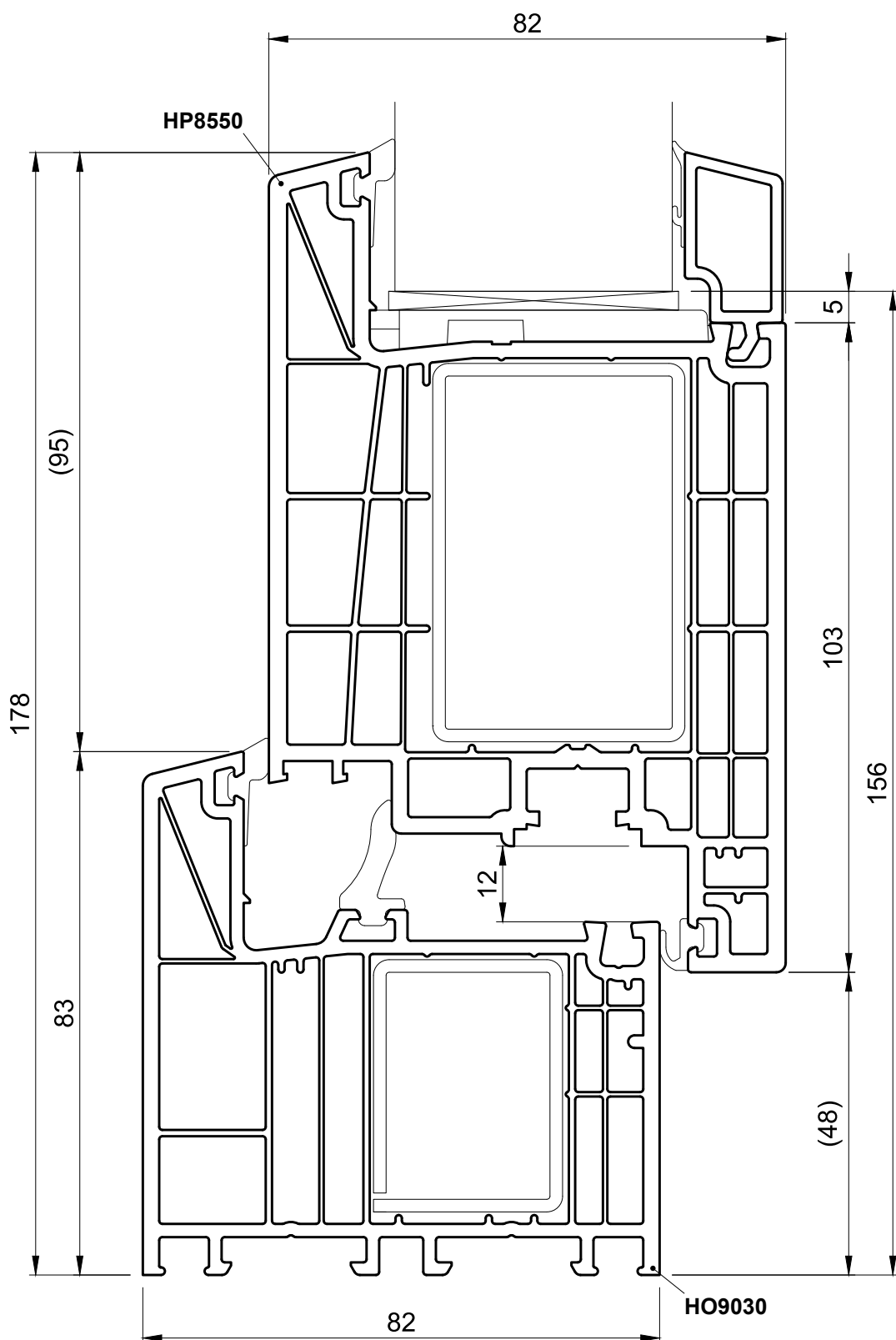

Sash  
**HP8550**

Frame  
**HO8030**

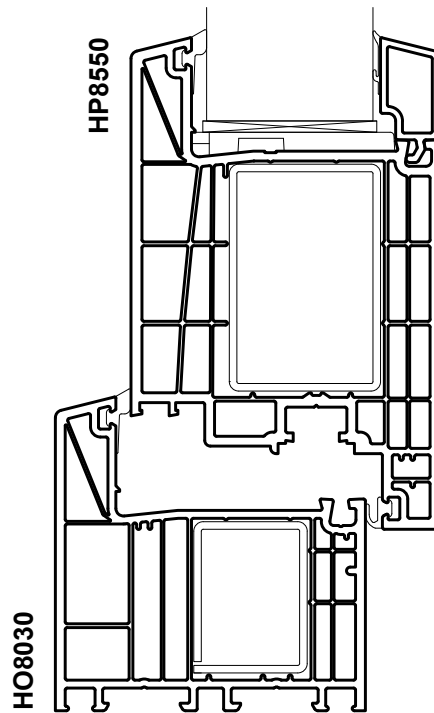

Sash  
HP8550

Frame  
HO9050

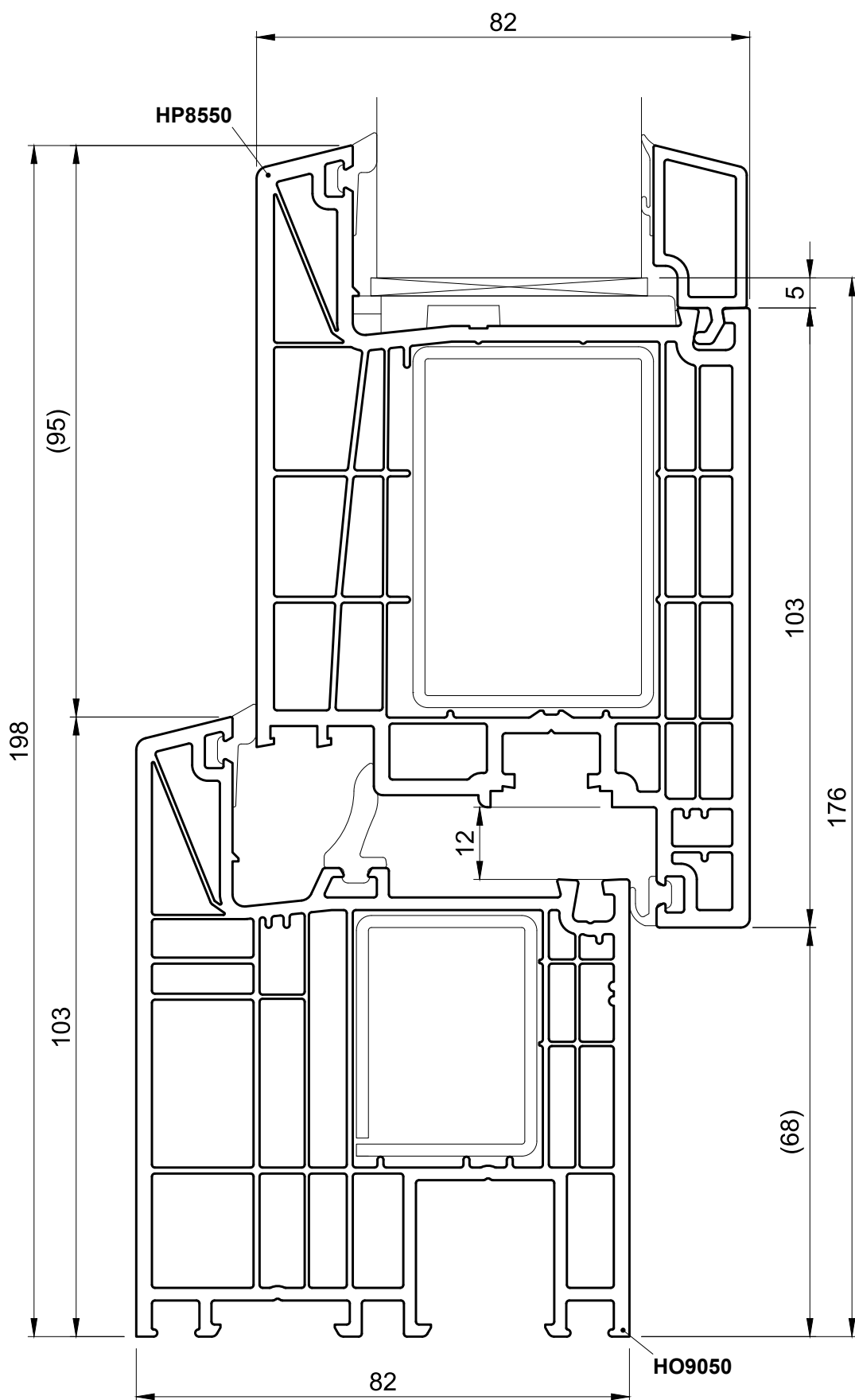

Sash  
HP8550

Old building frame  
HO9110

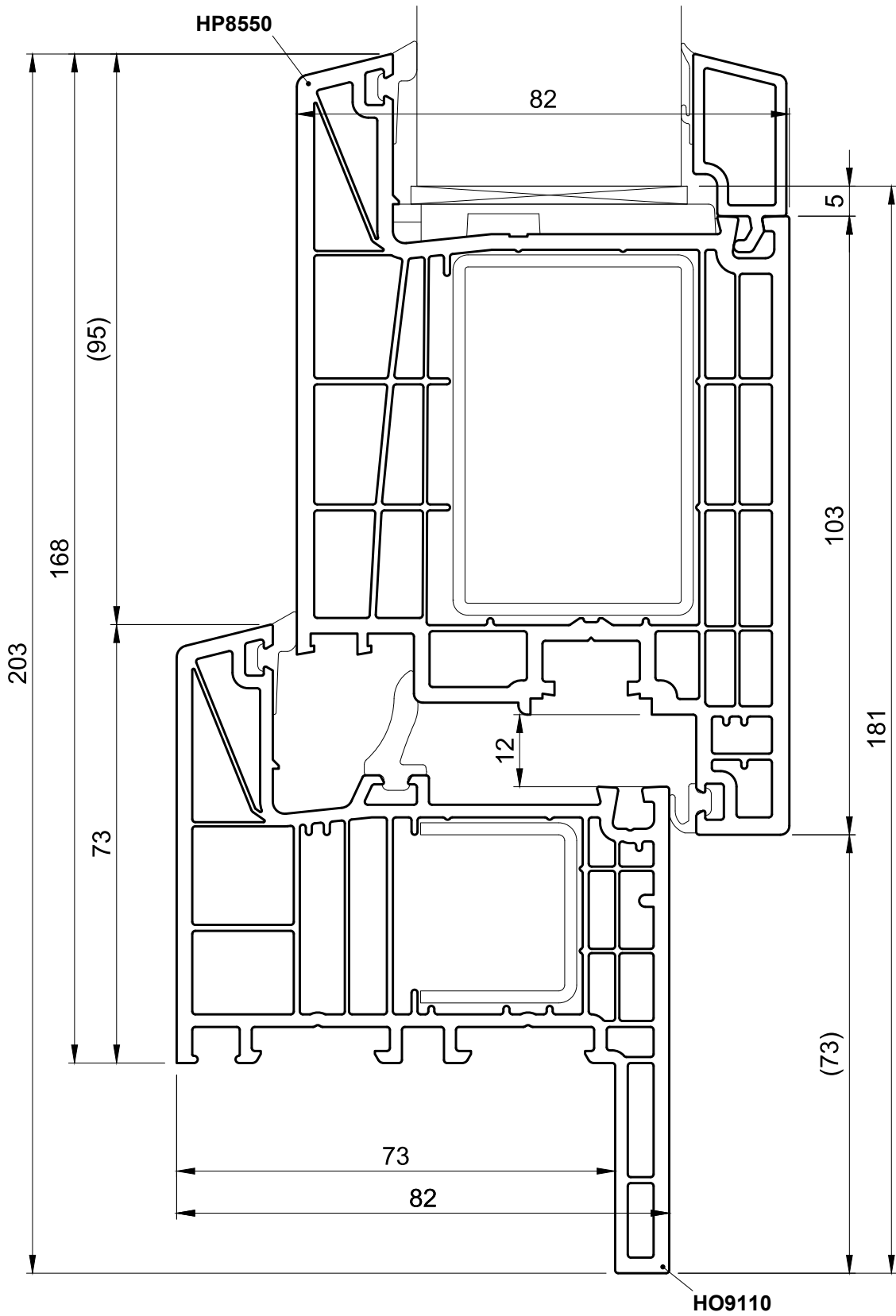

Sash  
HP8550

Old building frame  
HO9120

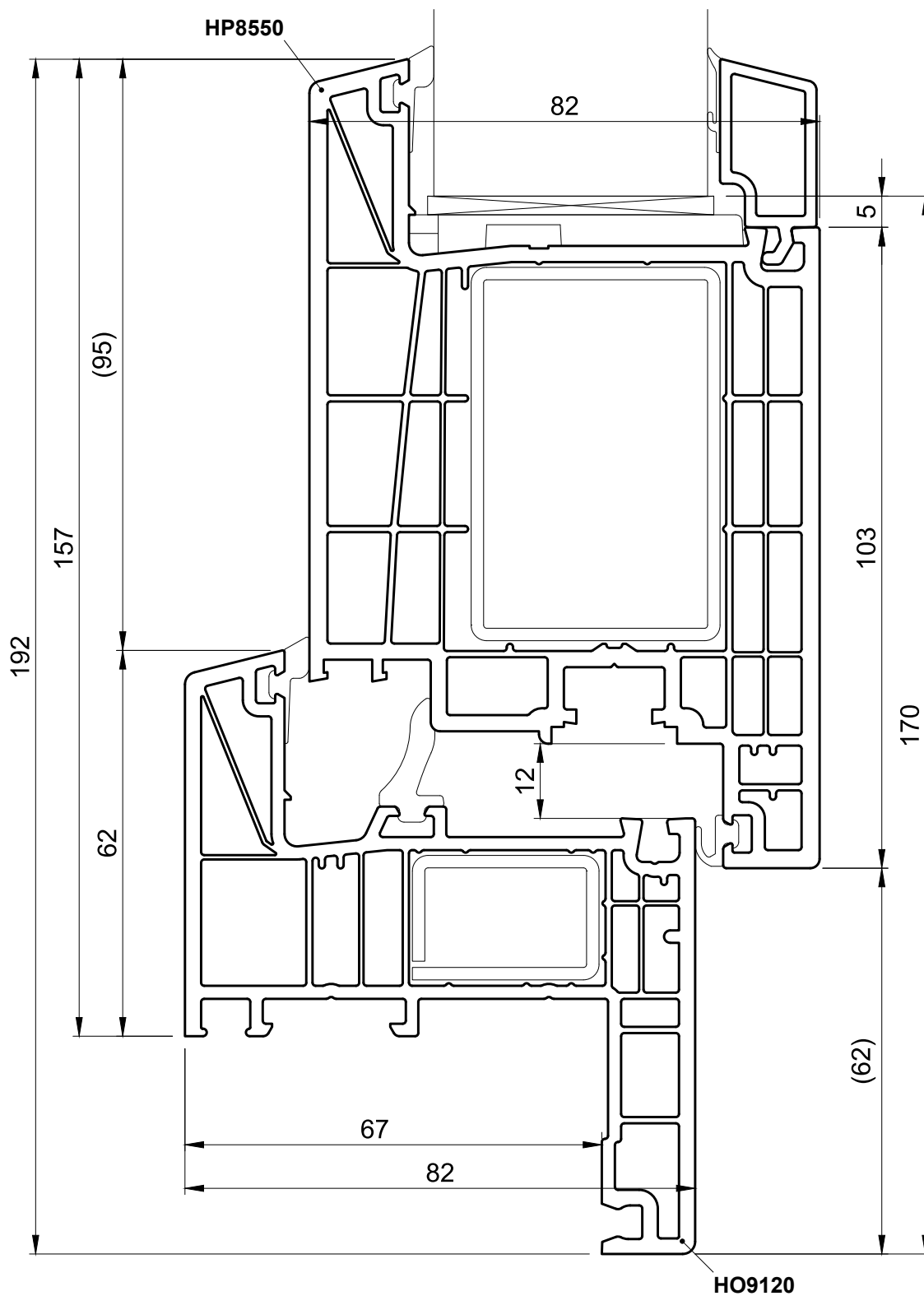

Sash  
HP8550

Old building frame  
HO9100

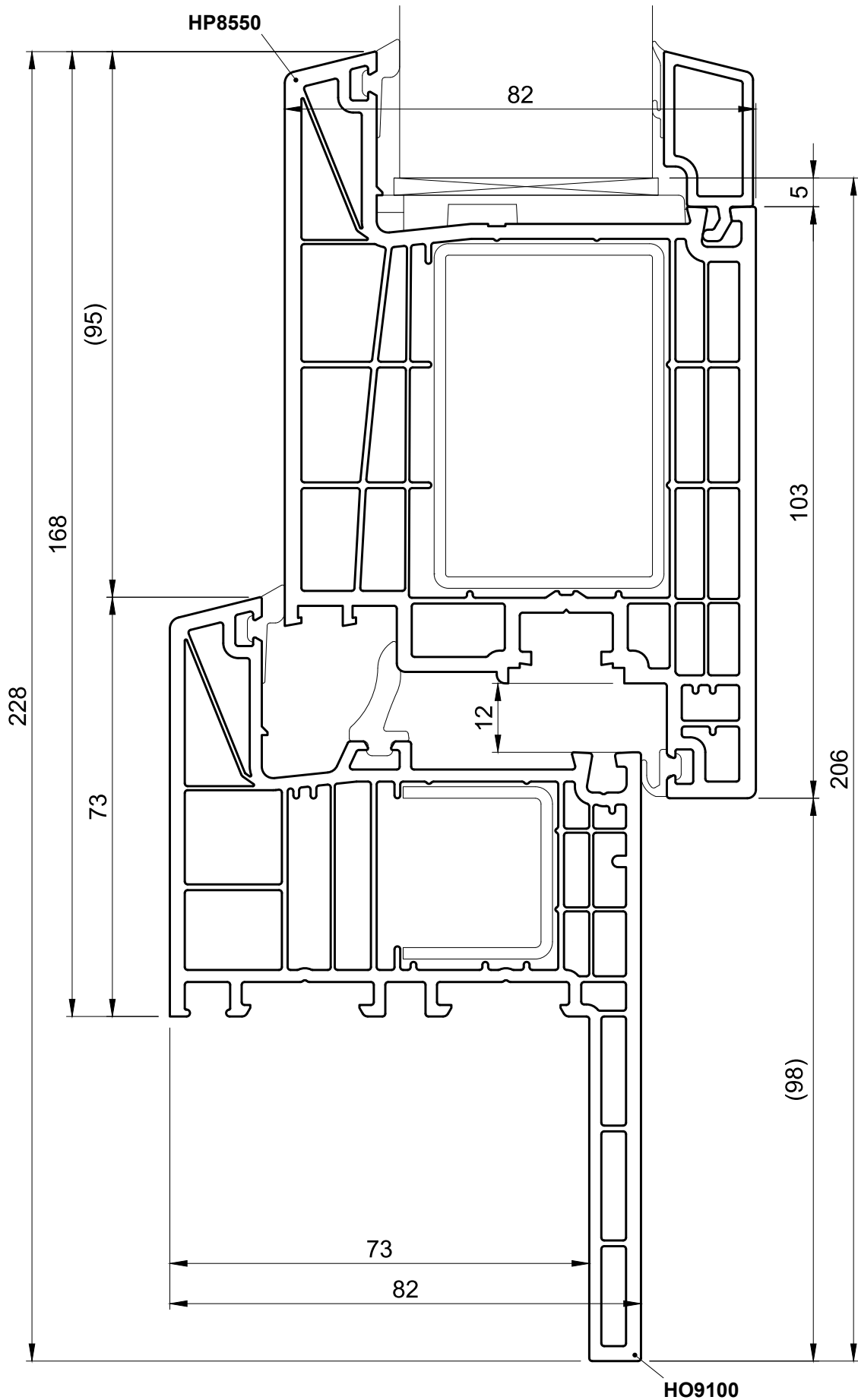

Sash  
HP8560

Frame  
HO9020

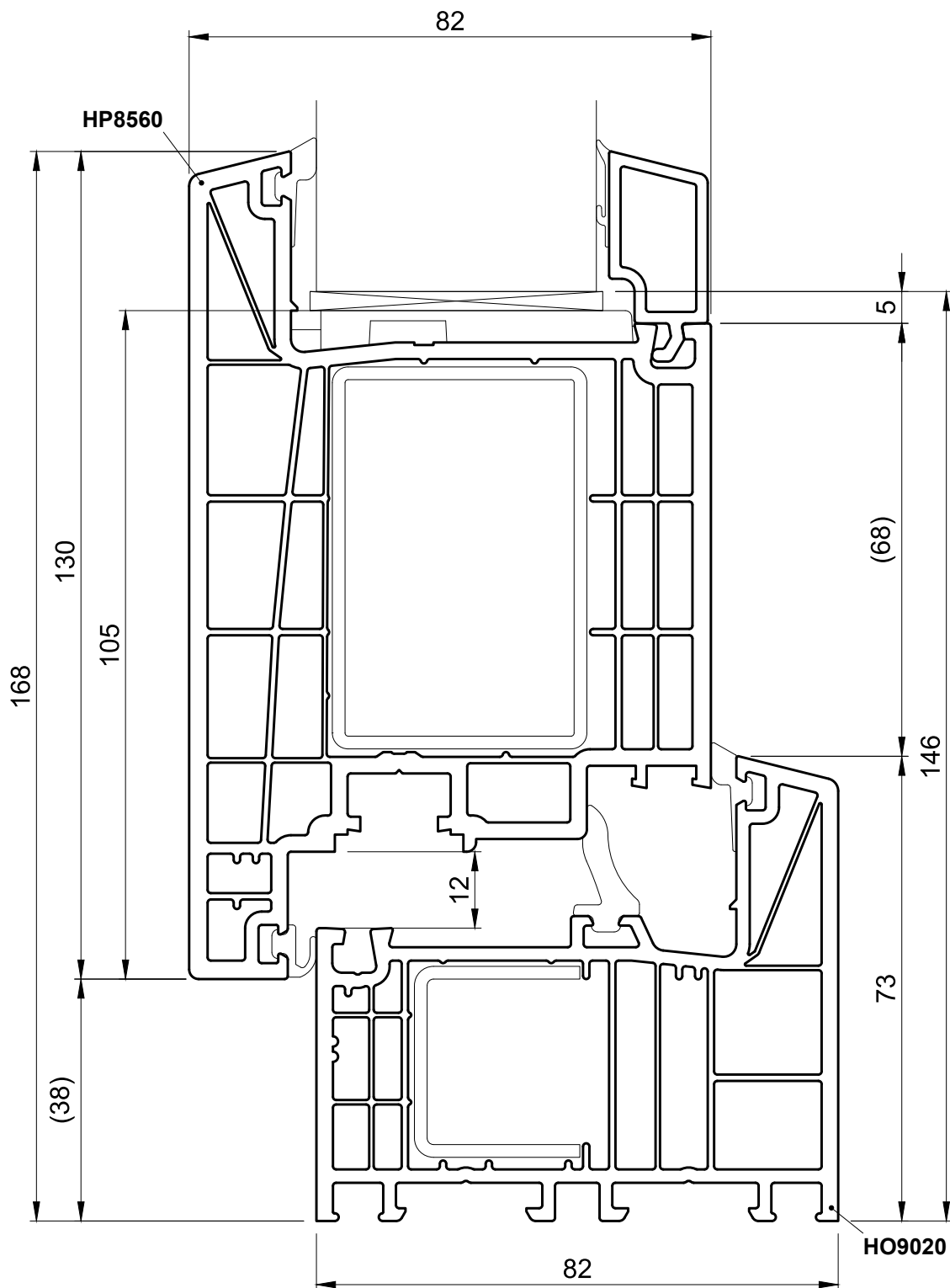

Sash  
**HP8560**

Frame  
**HO8020**

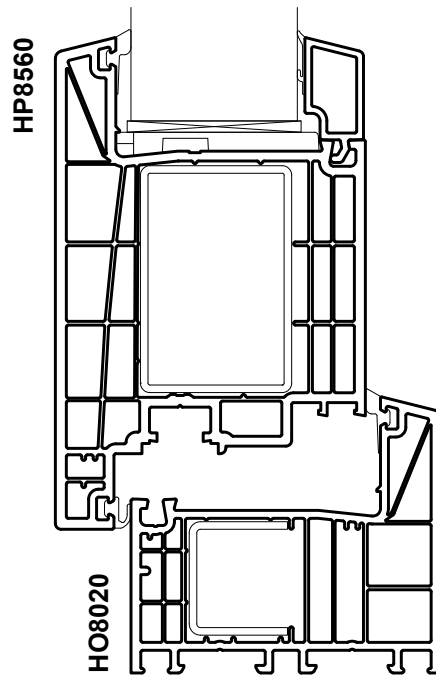

Sash  
HP8560

Frame  
HO9030

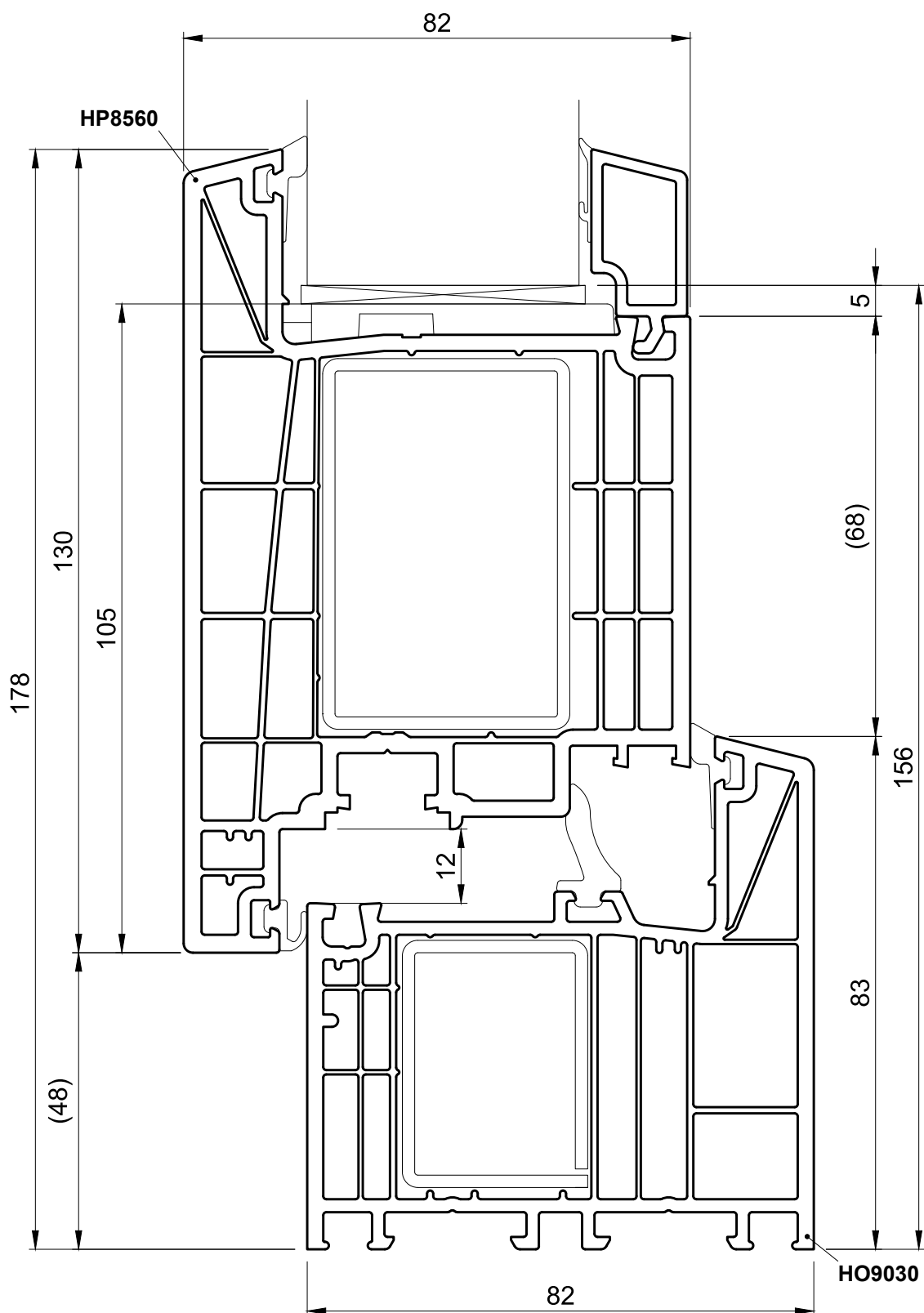

Sash  
**HP8560**

Frame  
**HO8030**

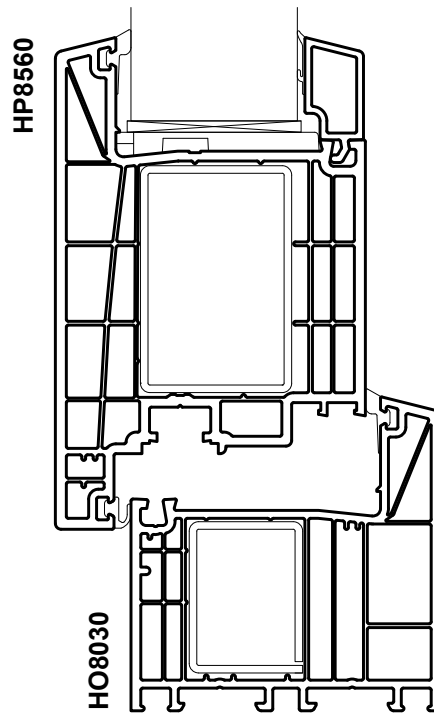

Sash  
HP8560

Frame  
HO9050

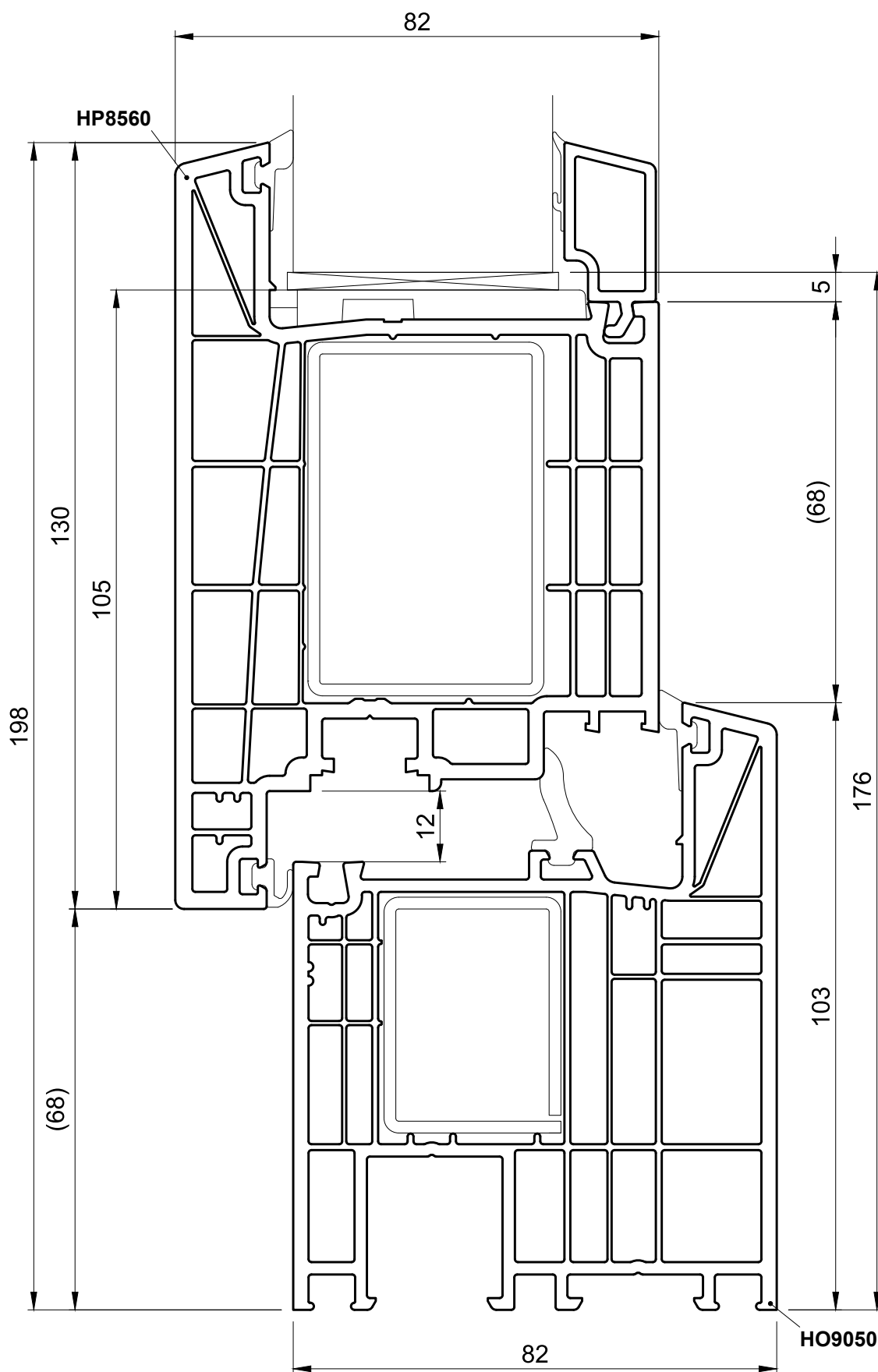

Sash  
HO8580

Frame  
HO9020

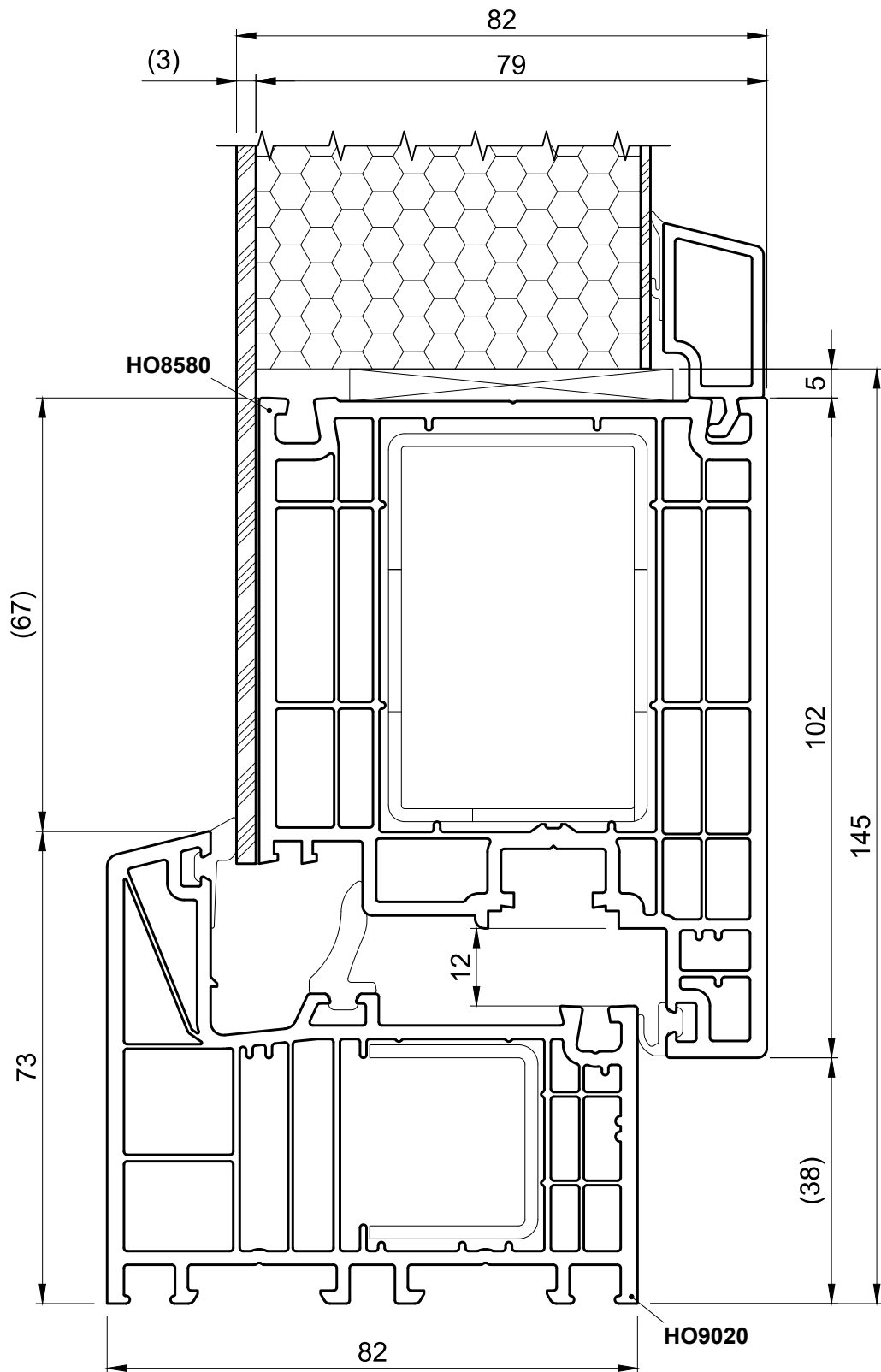

Sash  
HO8580

Frame  
HO8020

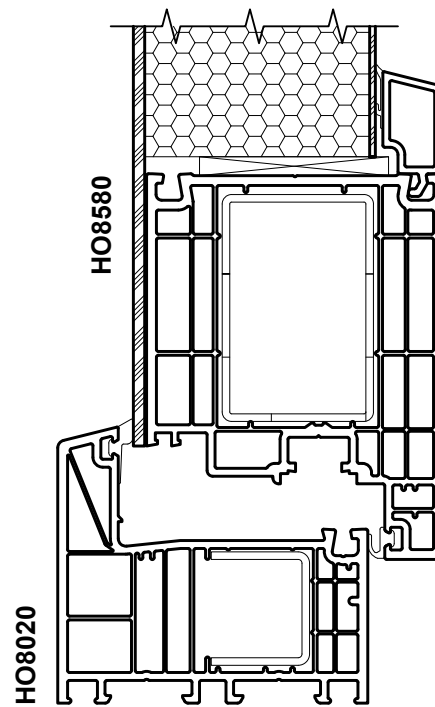

Sash  
HO8580

Frame  
HO9030

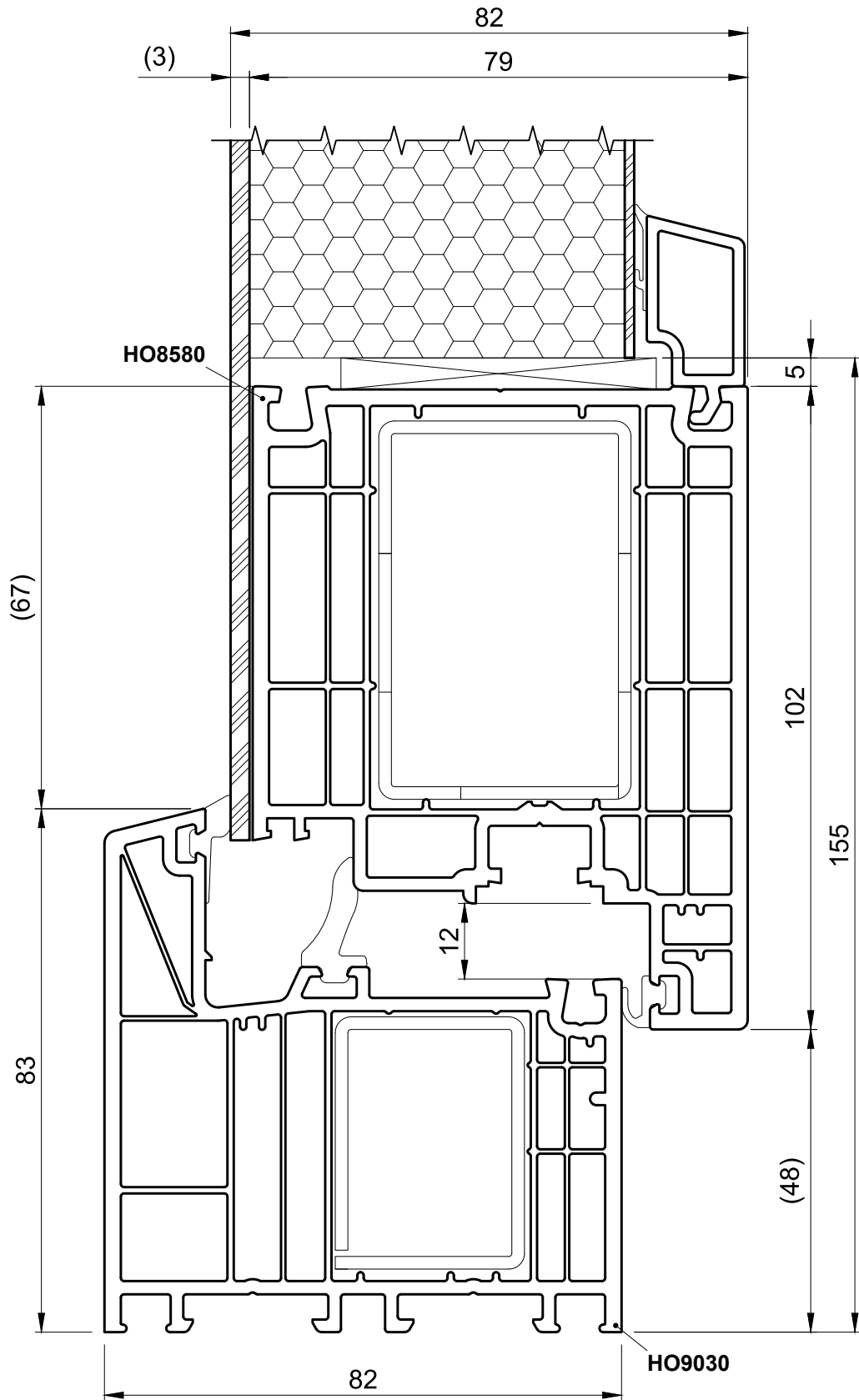

Sash  
HO8580

Frame  
HO8030

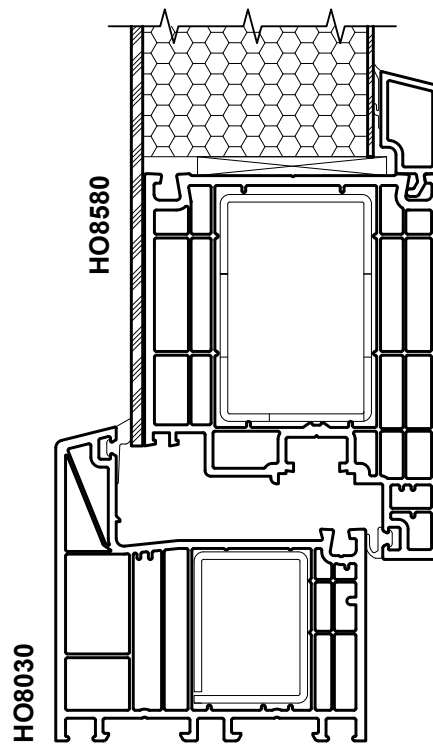

Sash  
HO8580

Frame  
HO9050

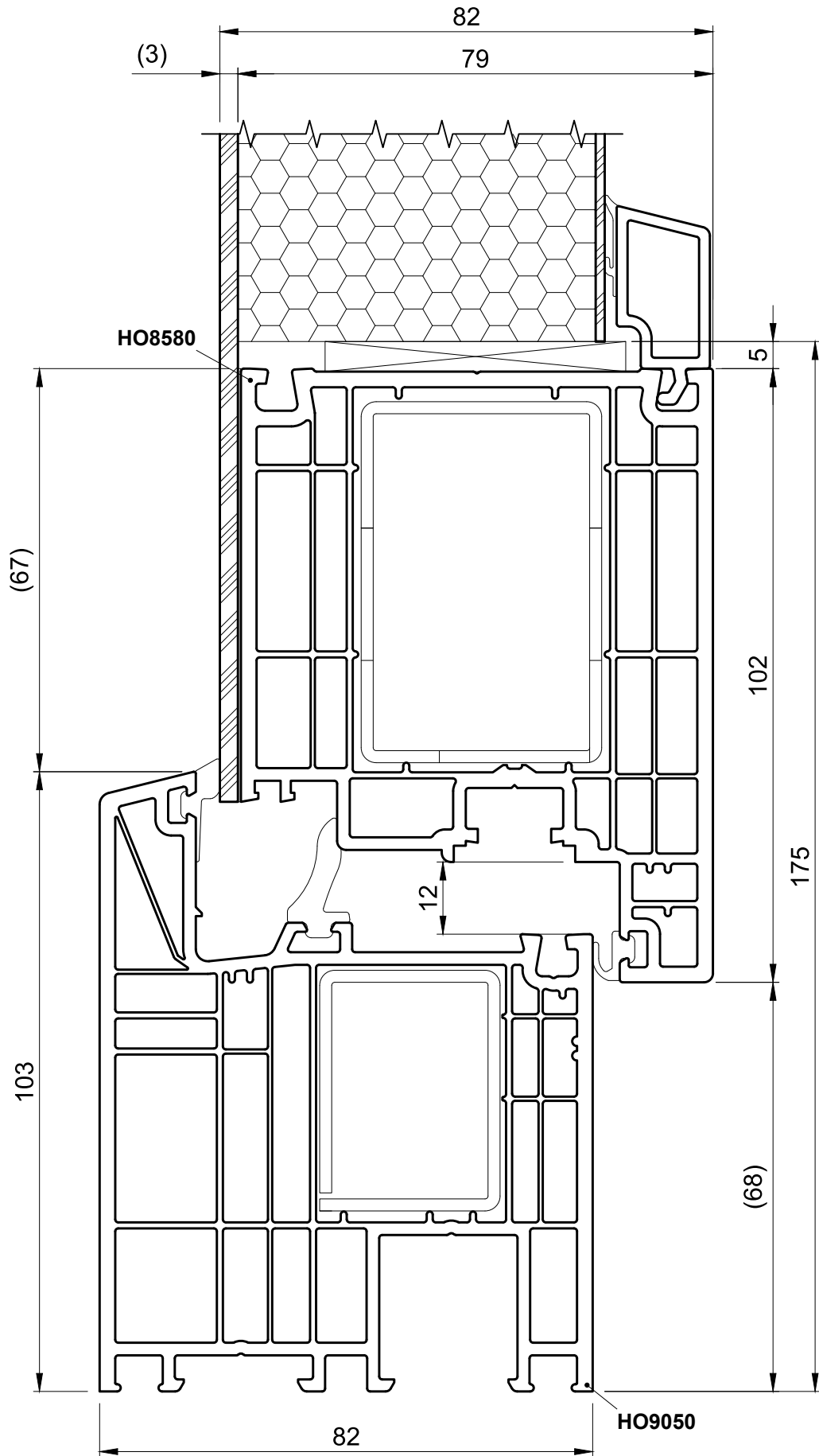

Sash  
HO8580

Old building frame  
HO9110

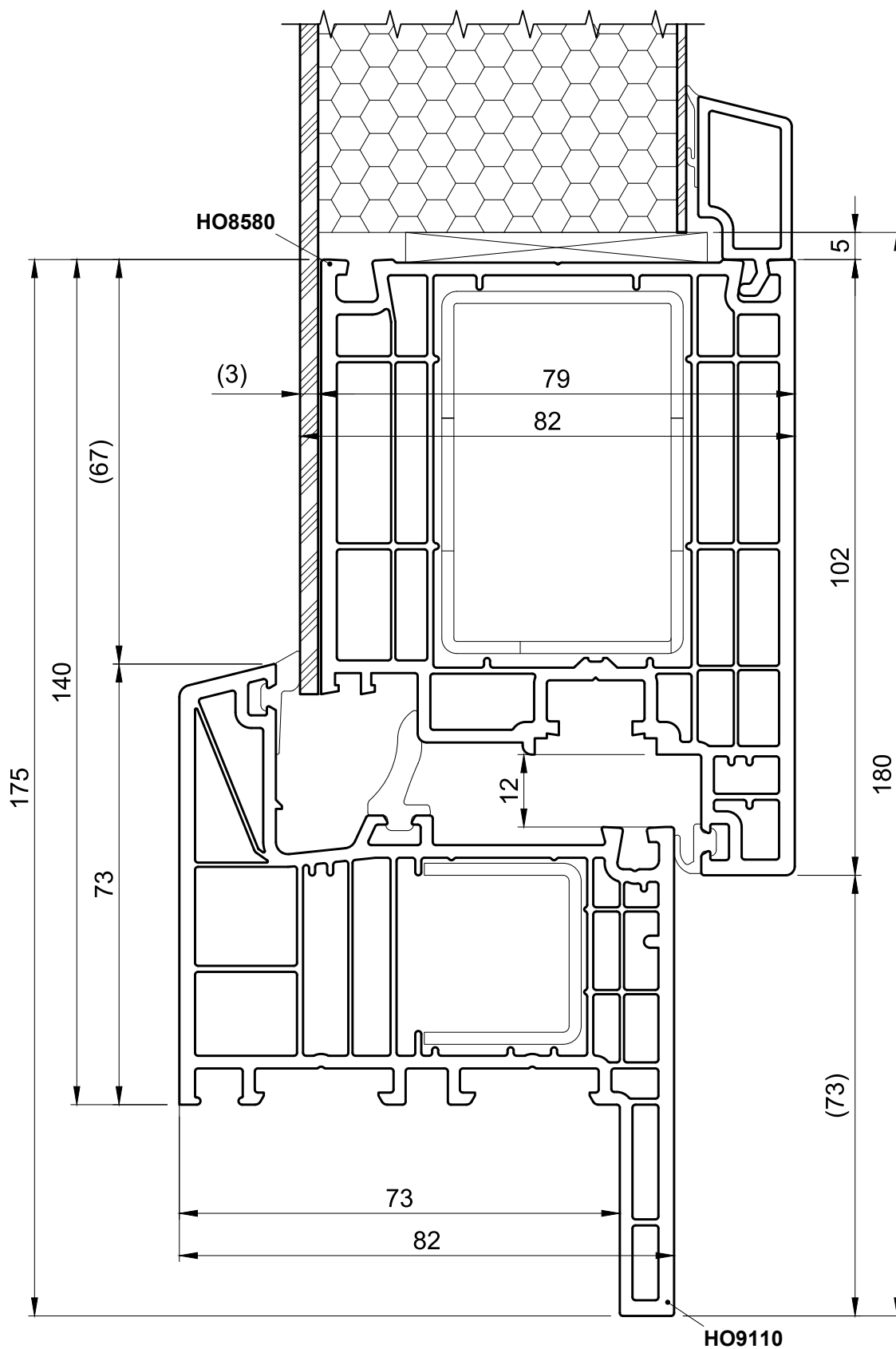

Sash  
HO8580

Old building frame  
HO9120

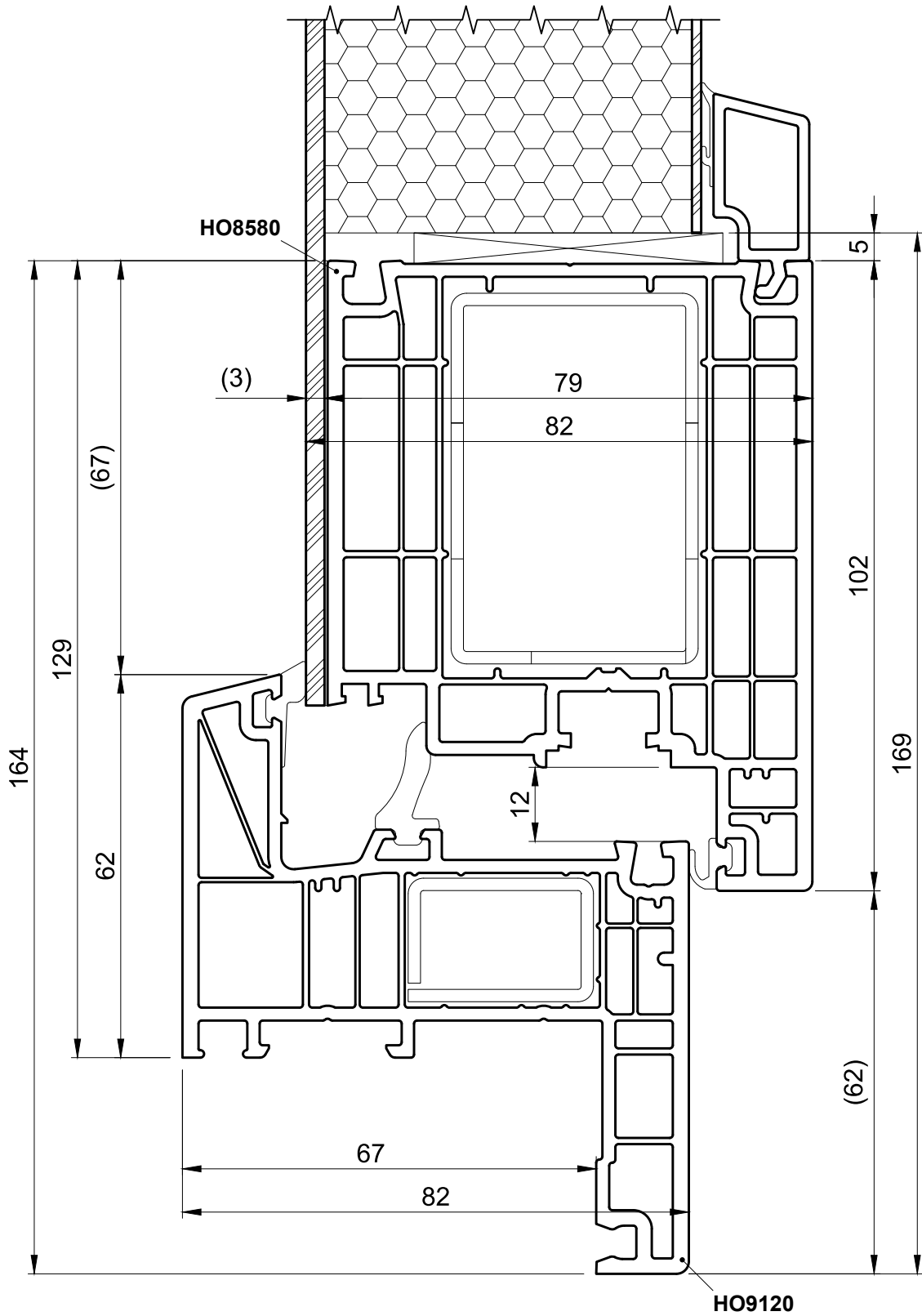

Sash  
HO8580

Old building frame  
HO9100

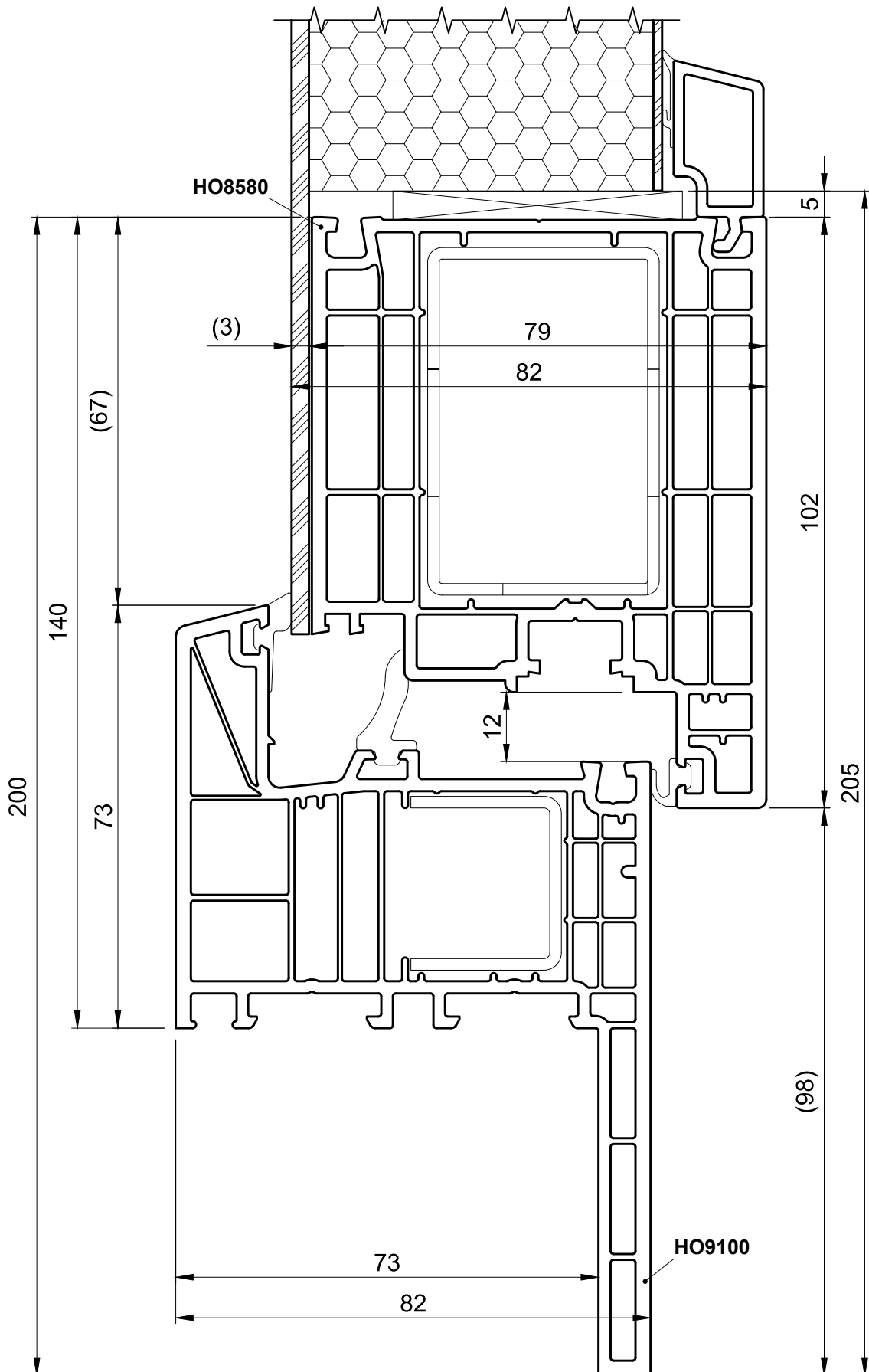

Fixed mullion  
HO9320, HO9310

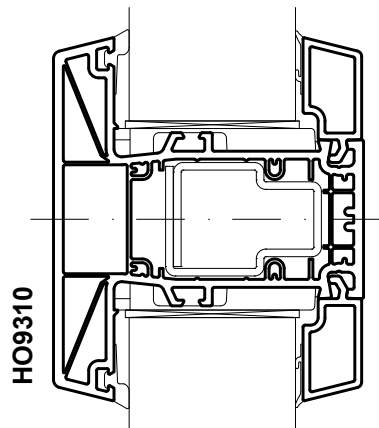
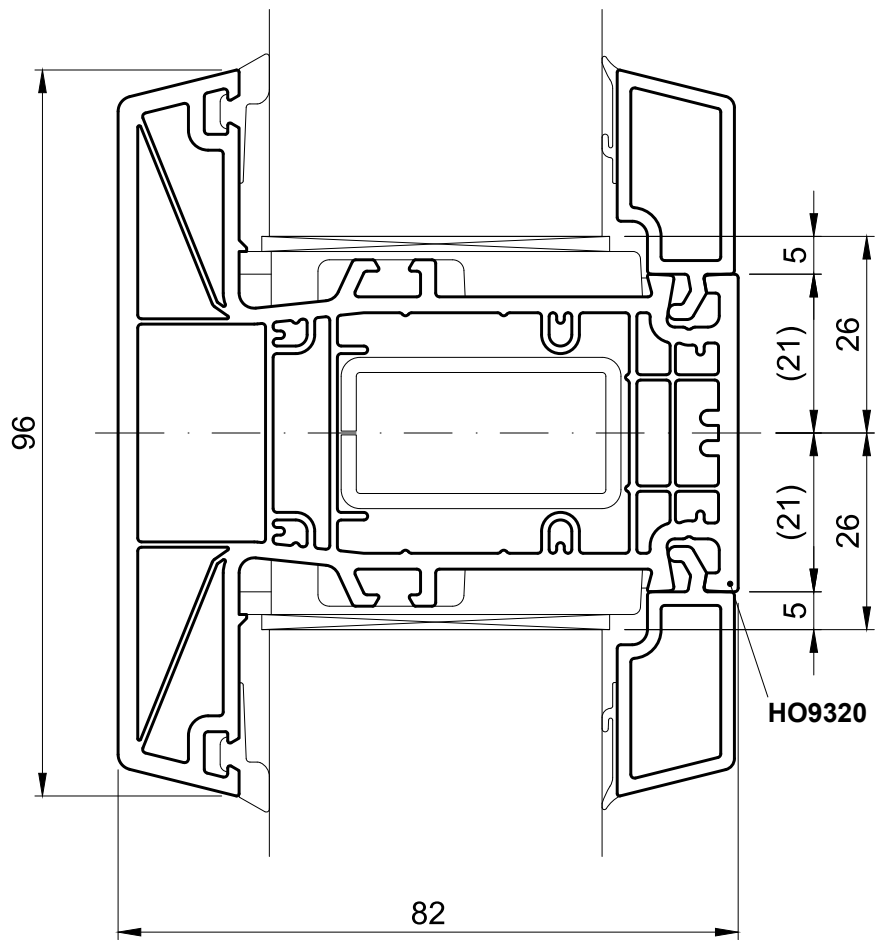

Fixed mullion  
HO8320, HO8310

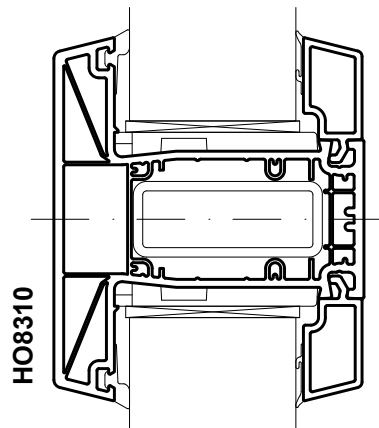
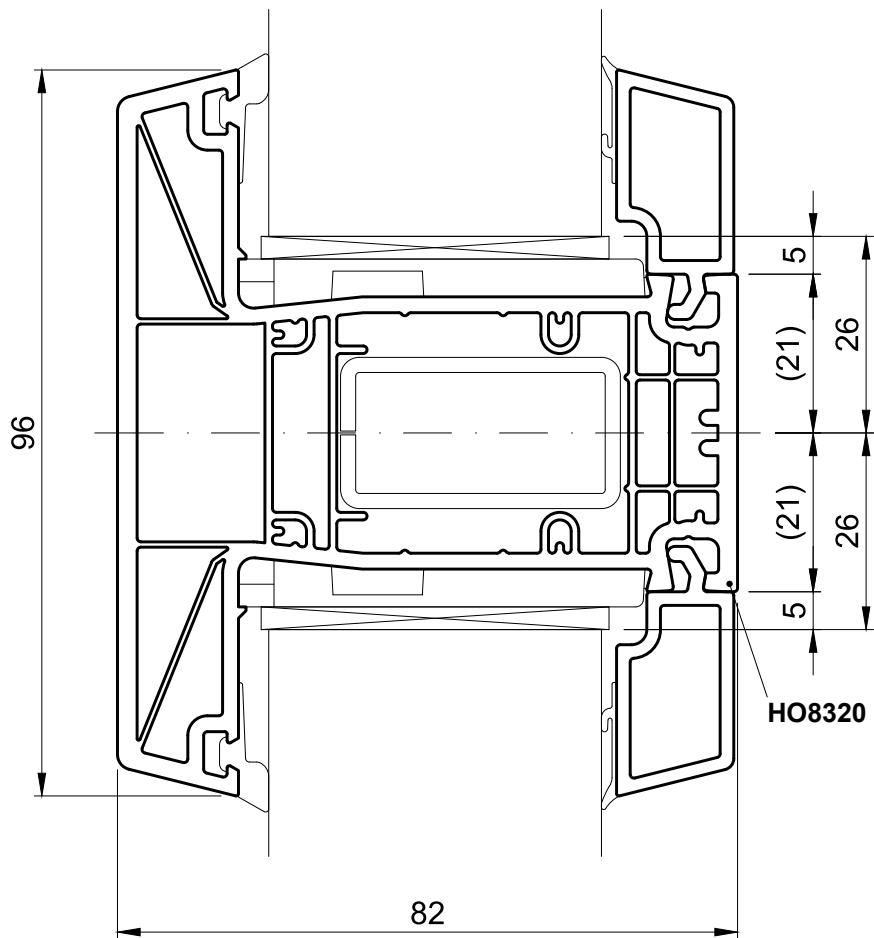

Fixed mullion  
HO9340, HO9330

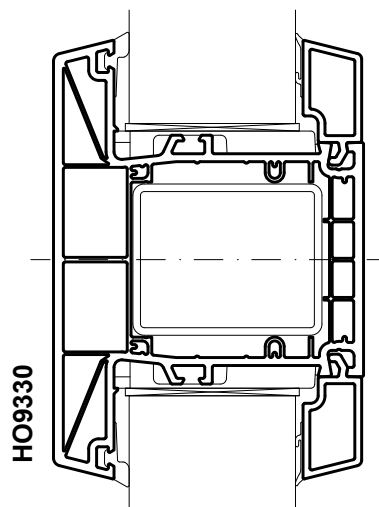
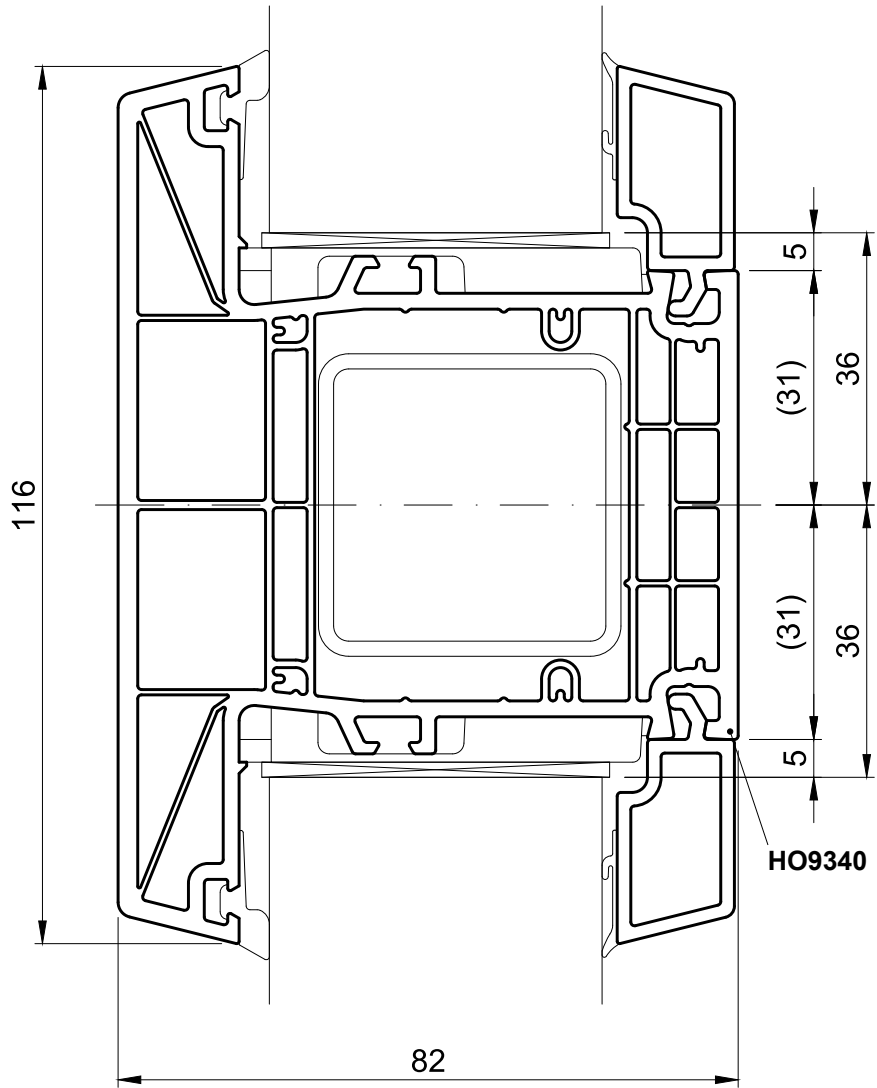

Fixed mullion

HP9420

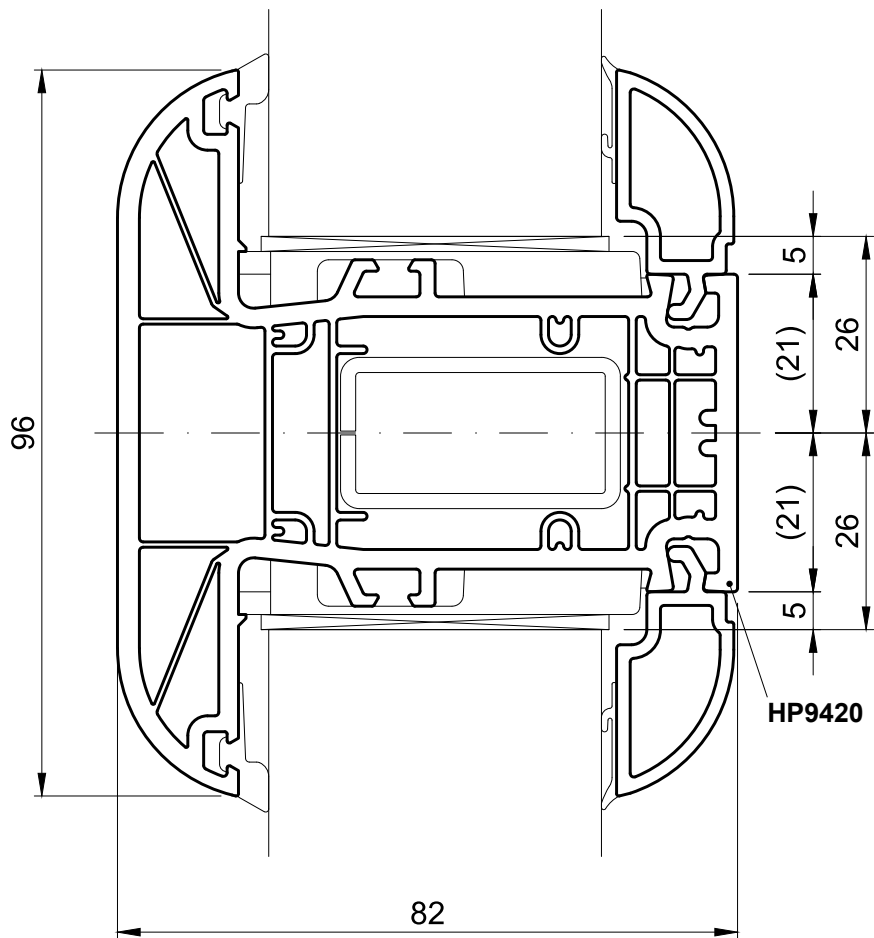

Glazing bar

**HO8300**

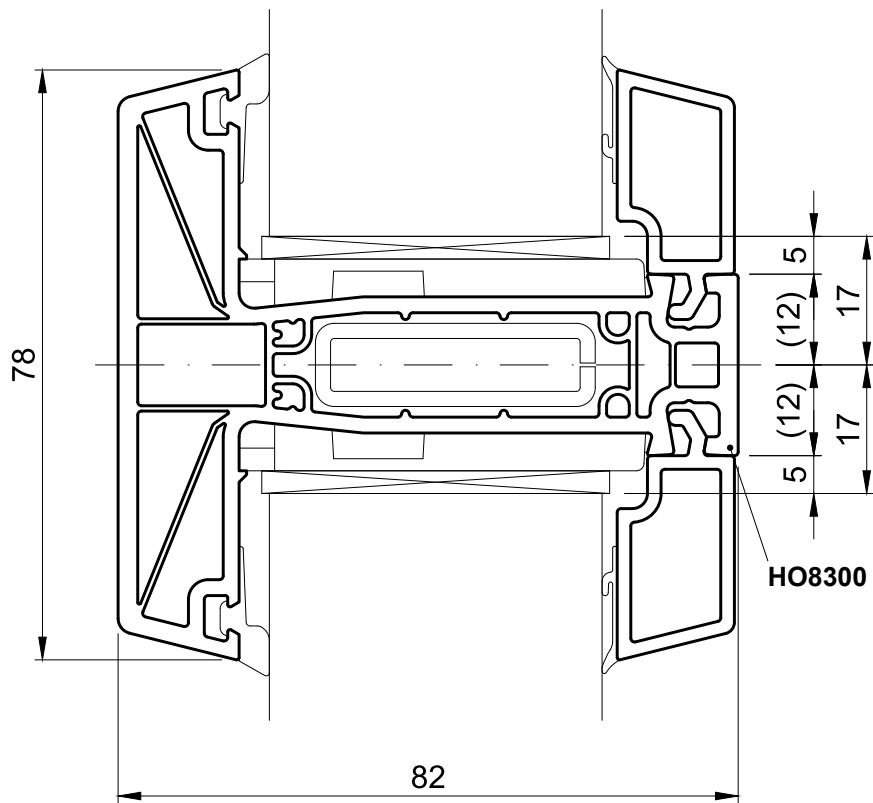

Sash  
HO8510

Fixed mullion  
HO9320

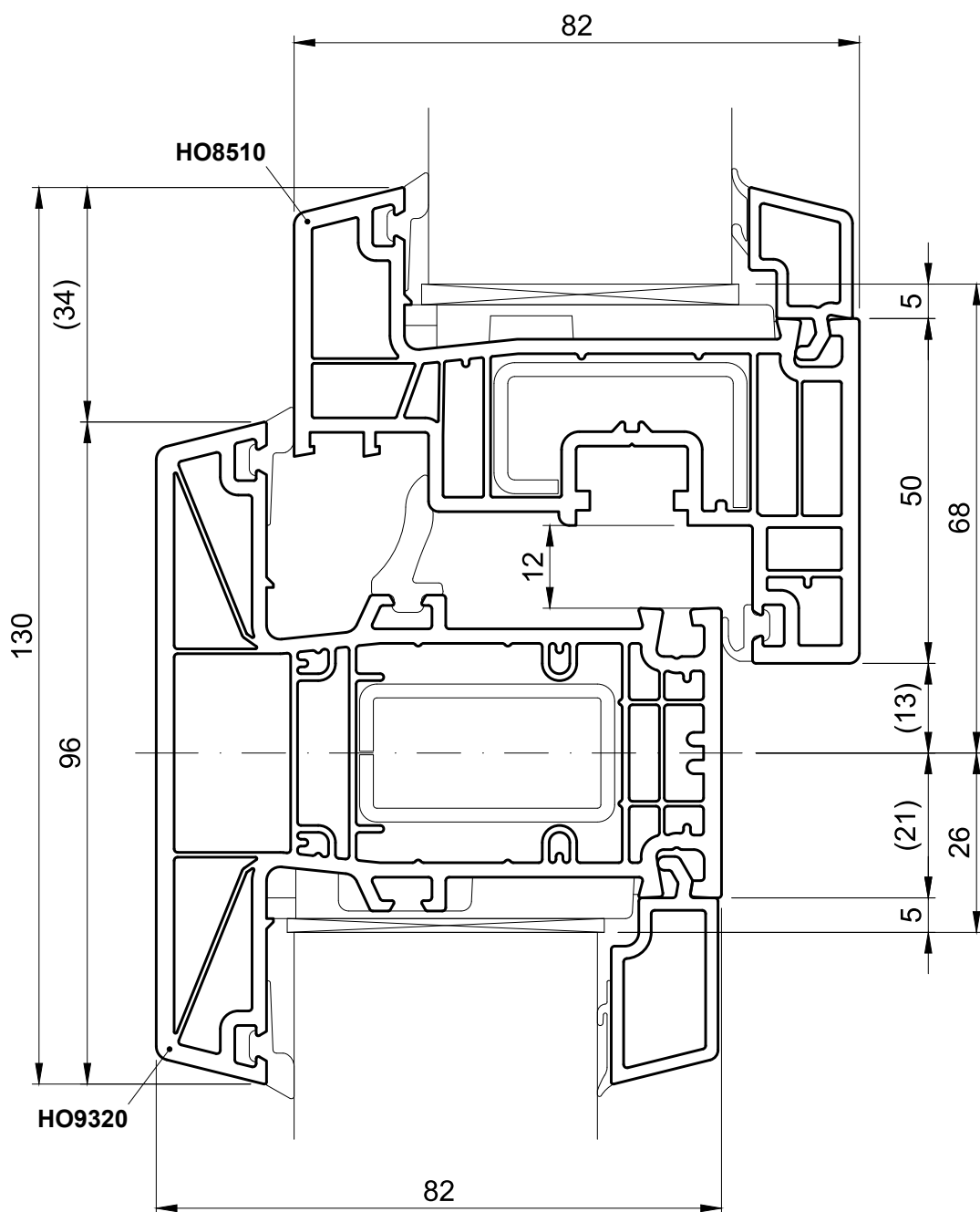

Sash  
HO8510

Fixed mullion  
HO9310, HO8320, HO8310

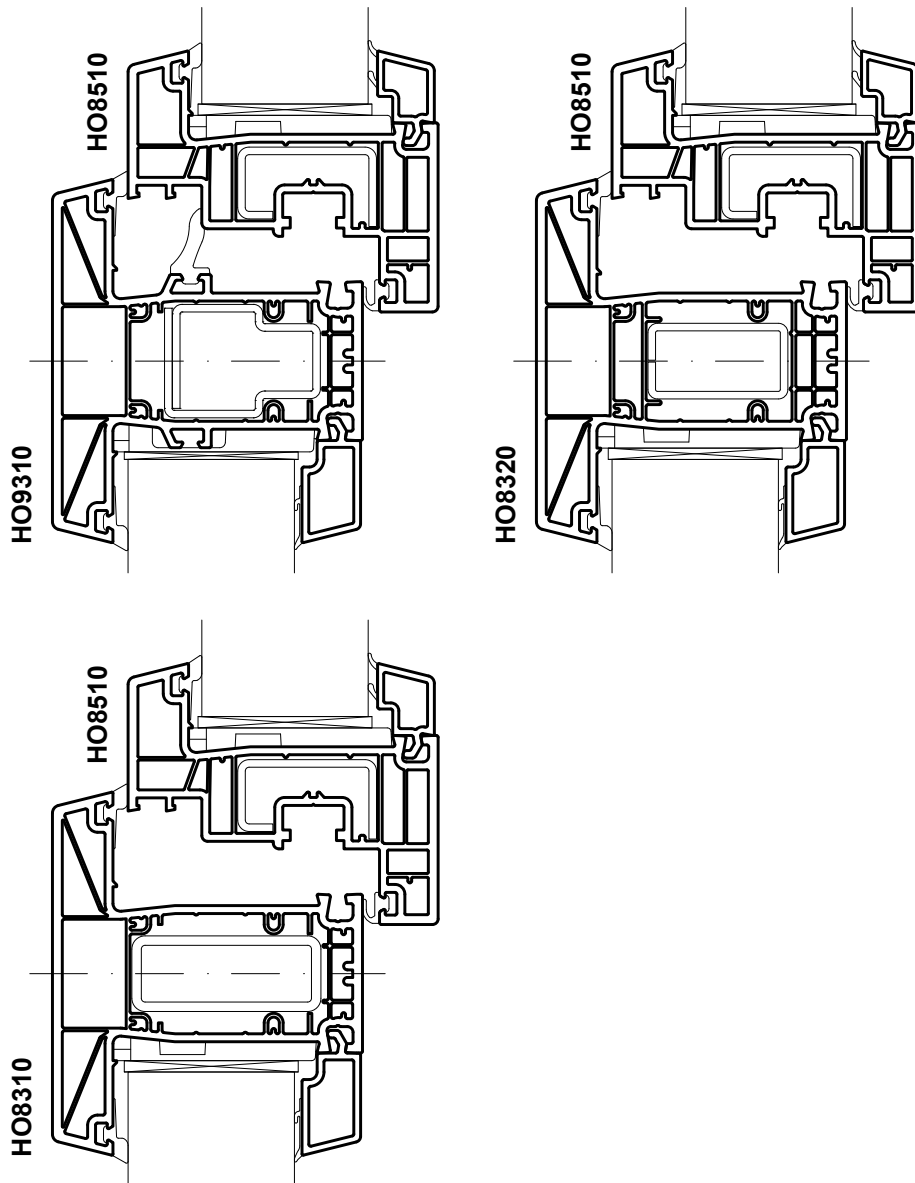

Sash  
HO8510

Fixed mullion  
HO9320

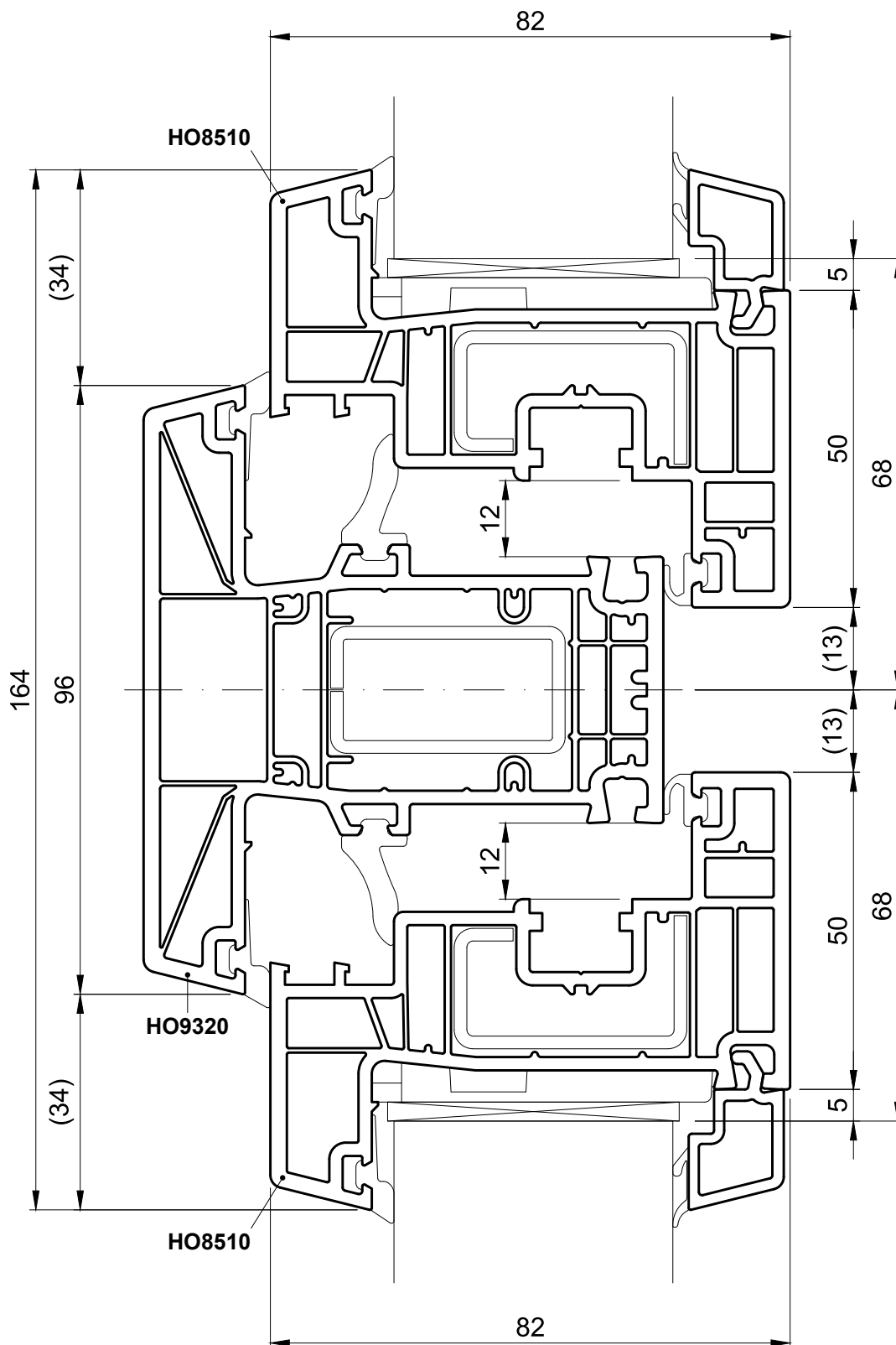

Sash  
HO8510

Fixed mullion  
HO9310, HO8320, HO8310

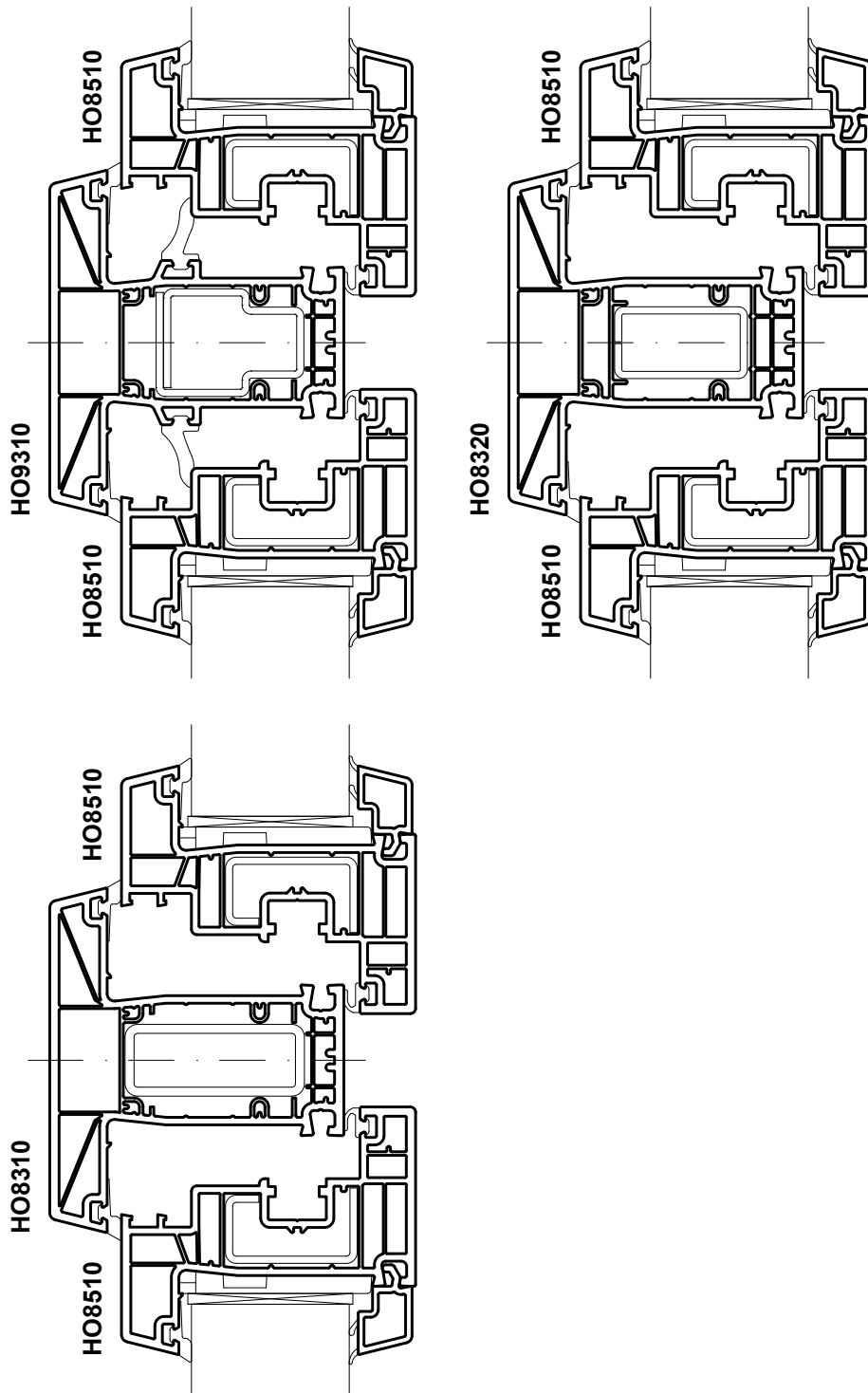

Sash  
HO8510

Fixed mullion  
HO9340

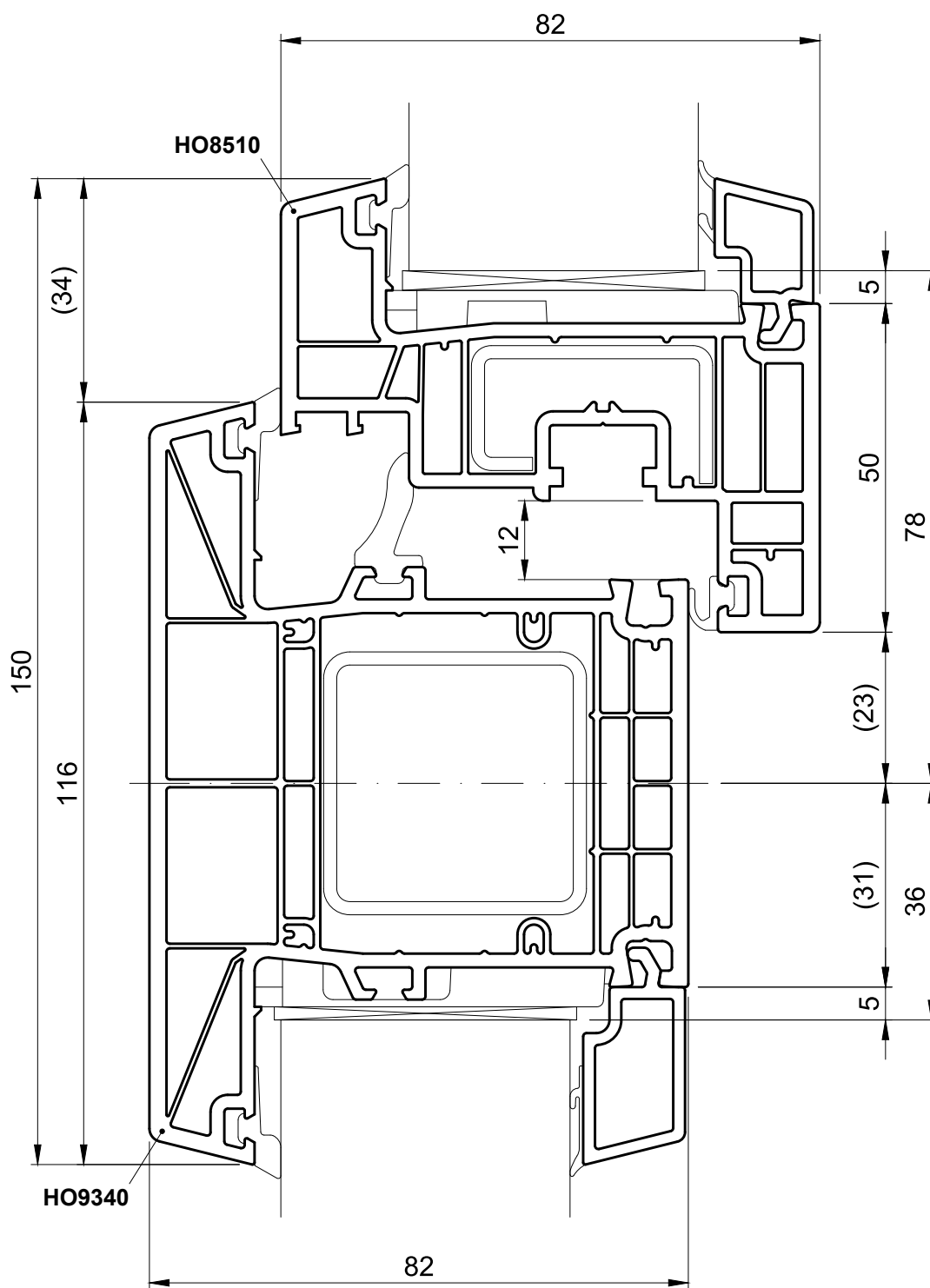

Sash  
**HO8510**

Fixed mullion  
**HO9330**

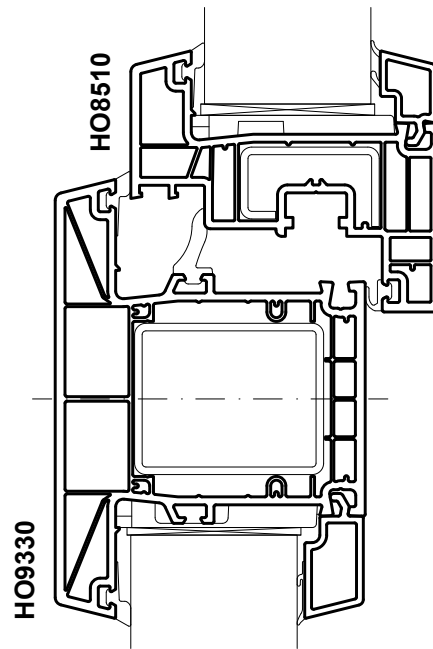

Sash  
HO8510

Fixed mullion  
HO9340

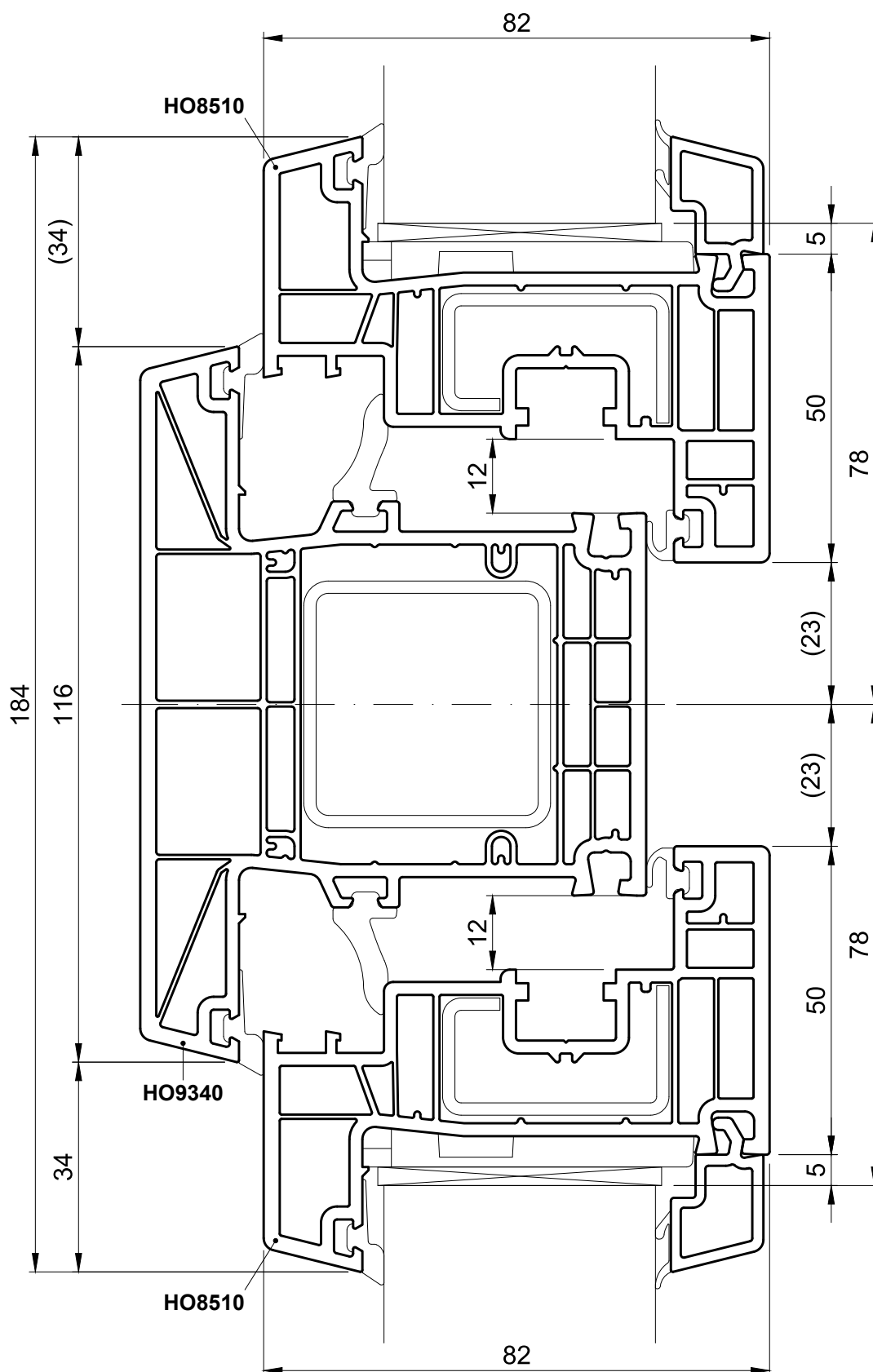

Sash  
**HO8510**

Fixed mullion  
**HO9330**

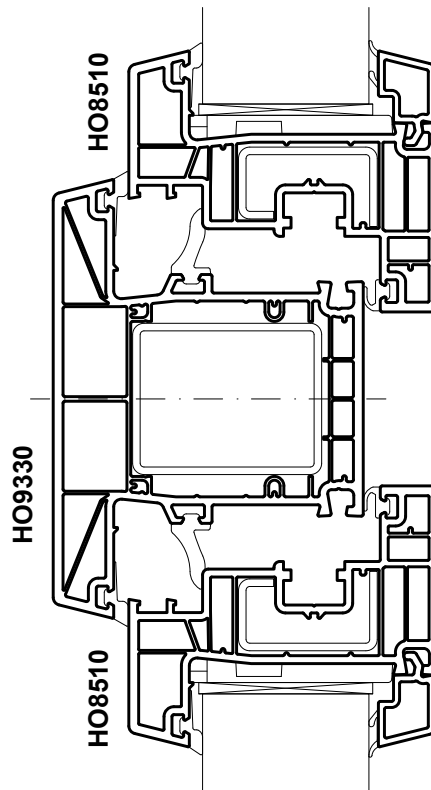

Sash  
HO8520

Fixed mullion  
HO9320

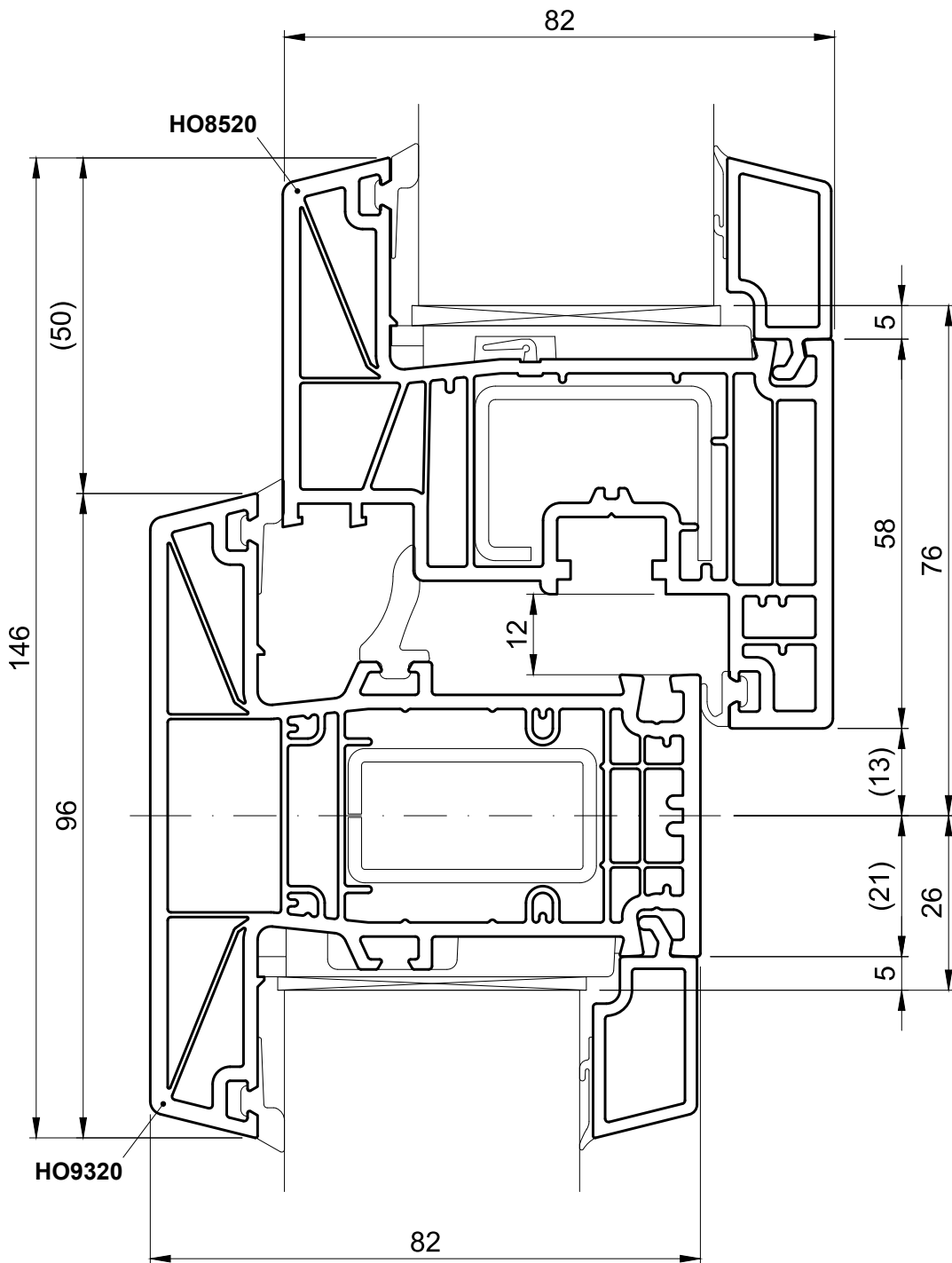

Sash  
HO8520

Fixed mullion  
HO9310, HO8320, HO8310

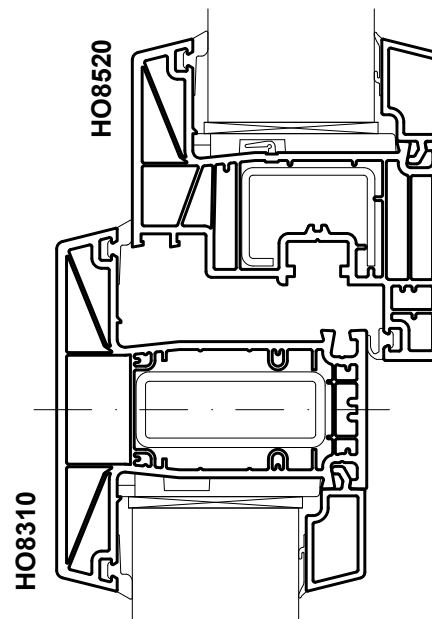
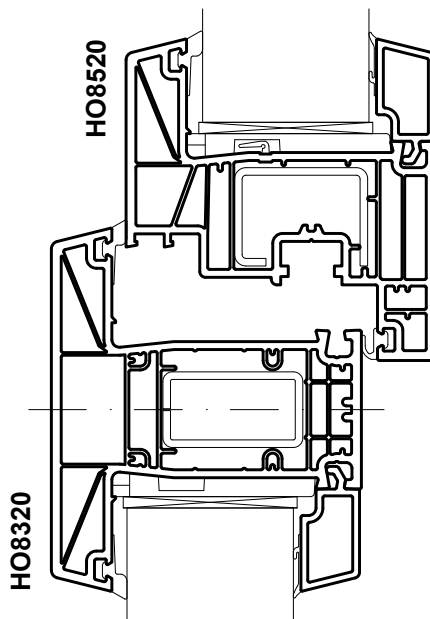
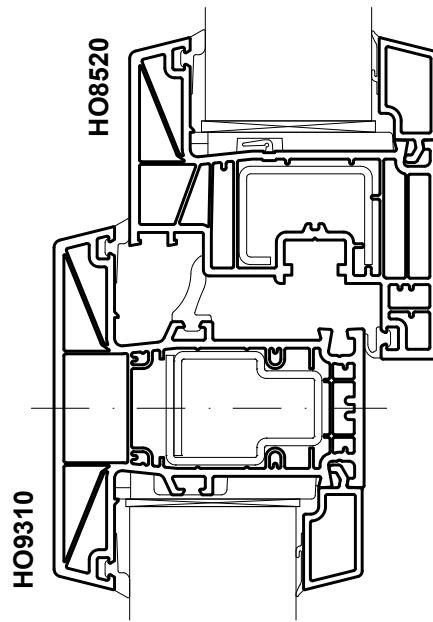

Sash  
HO8520

Fixed mullion  
HO9340

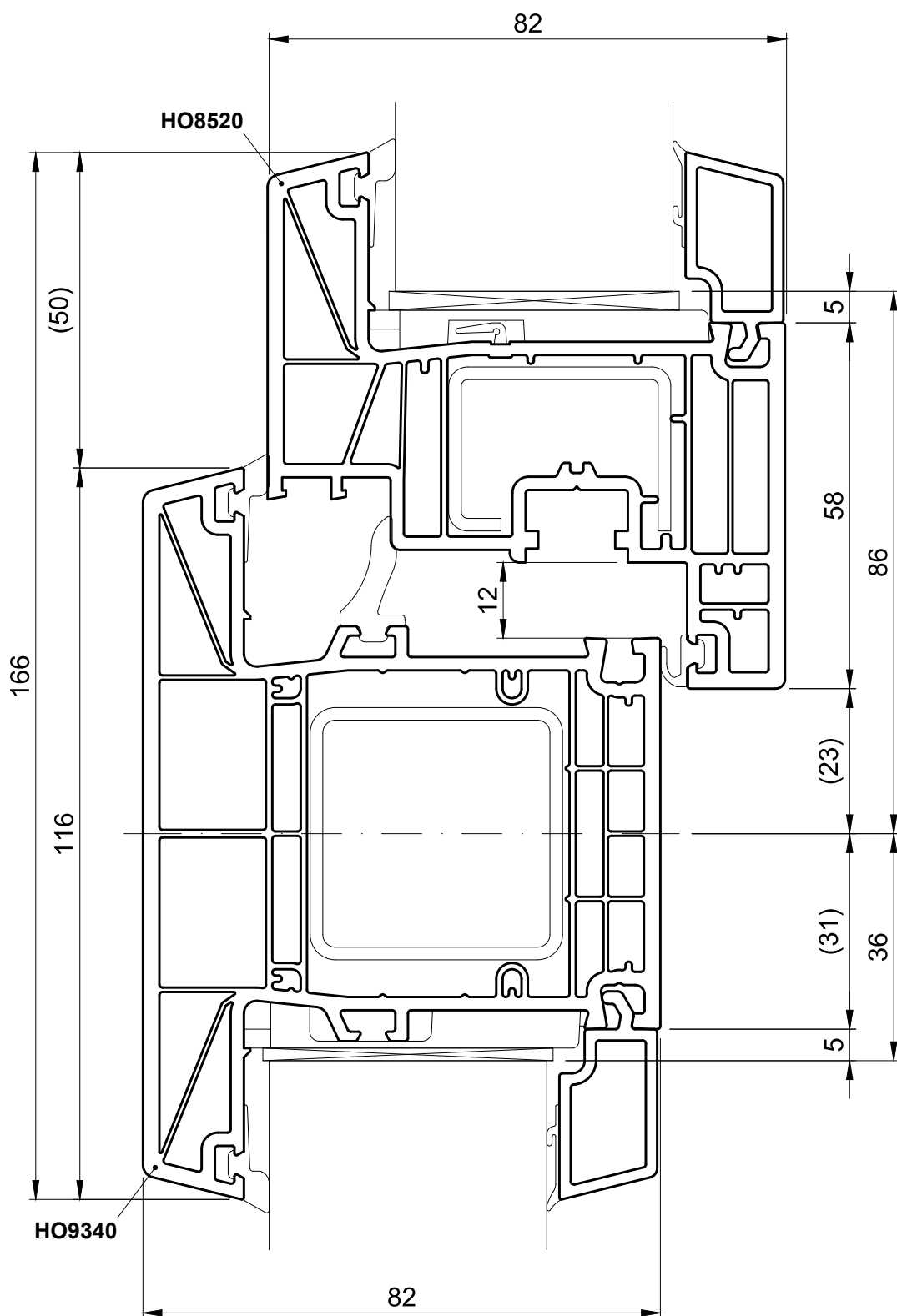

Sash  
**HO8520**

Fixed mullion  
**HO9330**

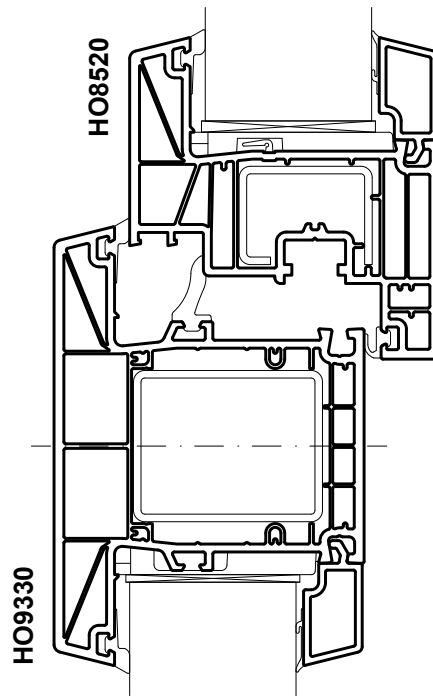

Sash  
HO8520

Fixed mullion  
HO9320

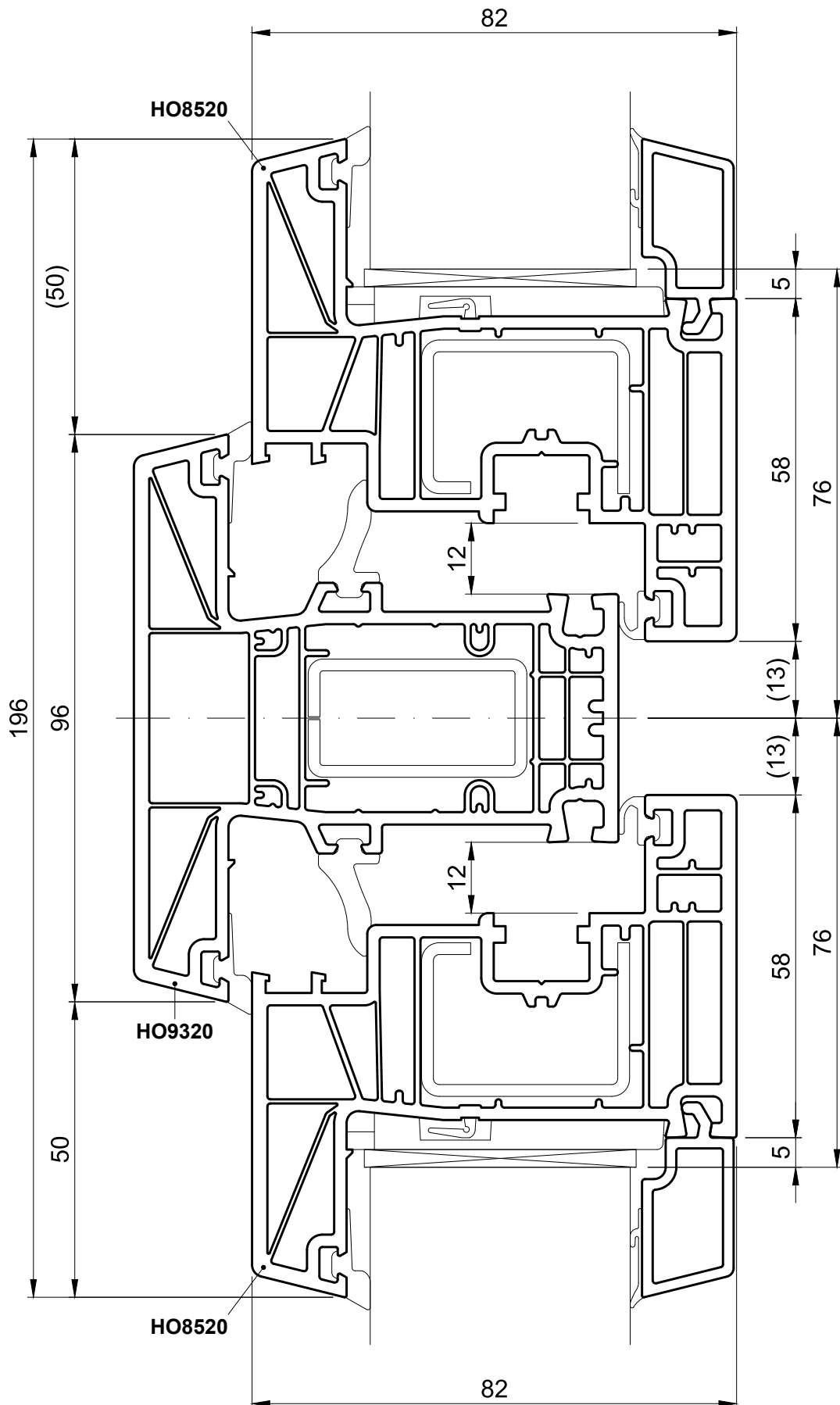

Sash  
HO8520

Fixed mullion  
HO9310, HO8320, HO8310

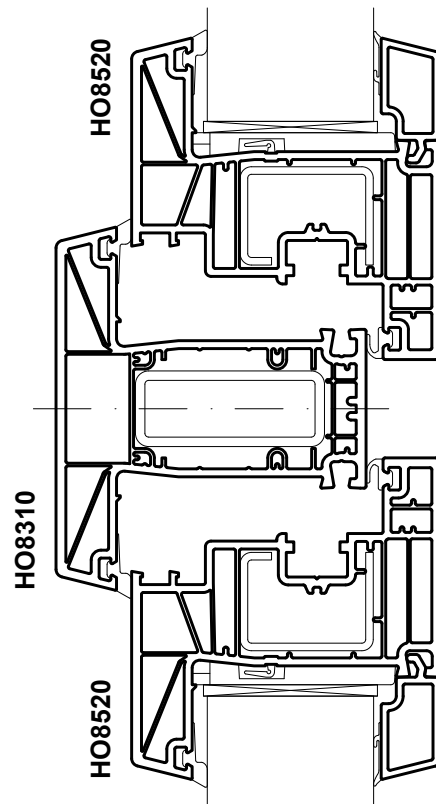
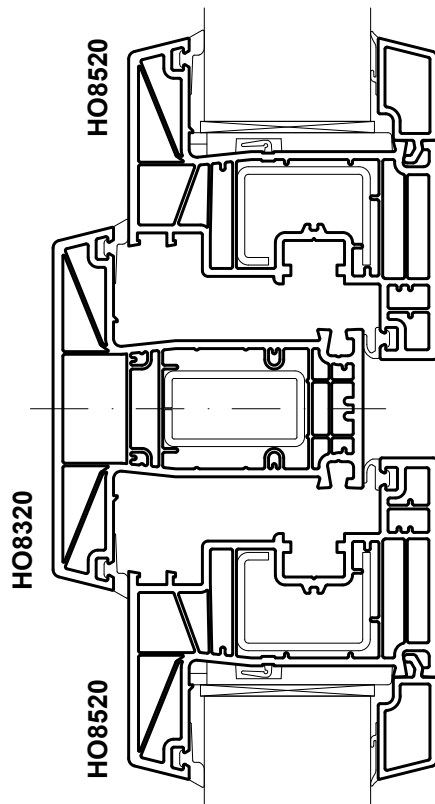
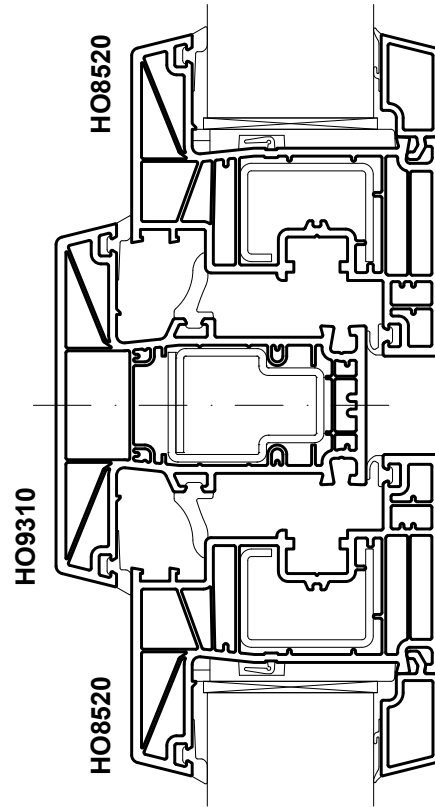

Sash  
HO8520

Fixed mullion  
HO9340

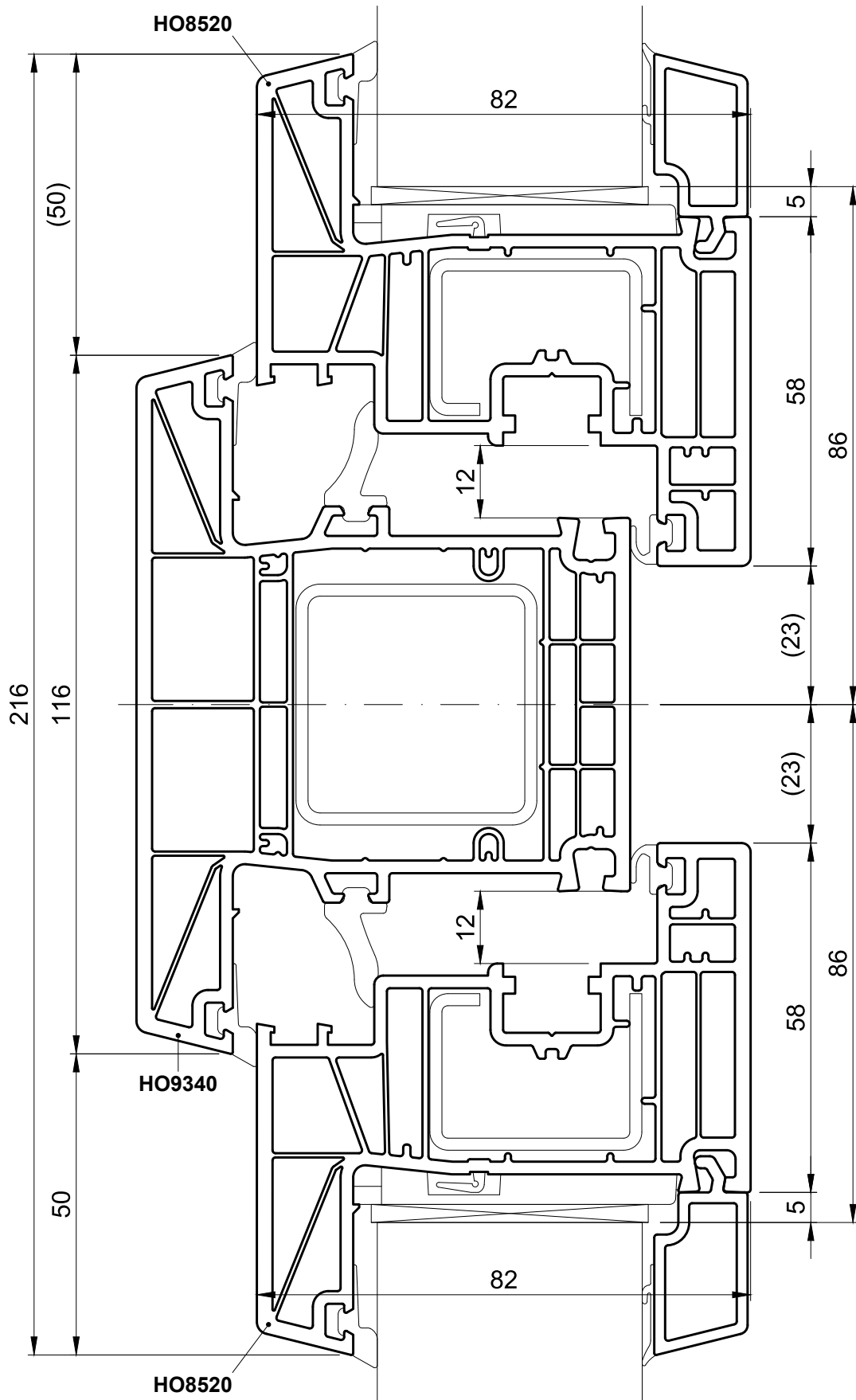

Sash  
**HO8520**

Fixed mullion  
**HO9330**

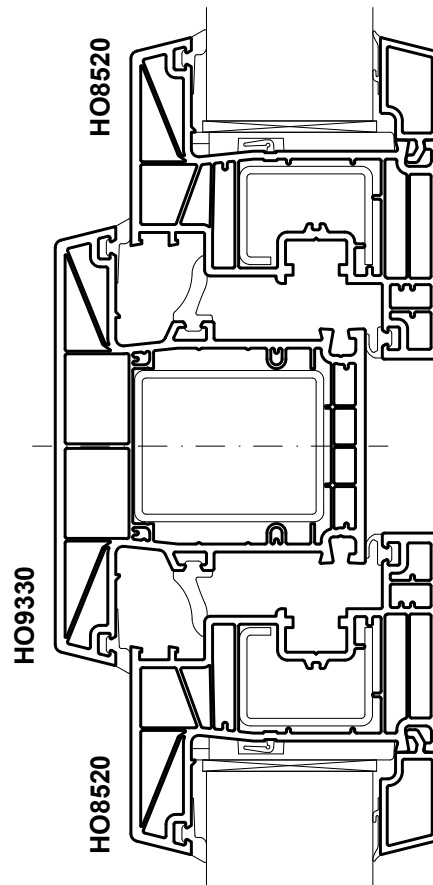

Sash  
HP8920

Fixed mullion  
HP9420

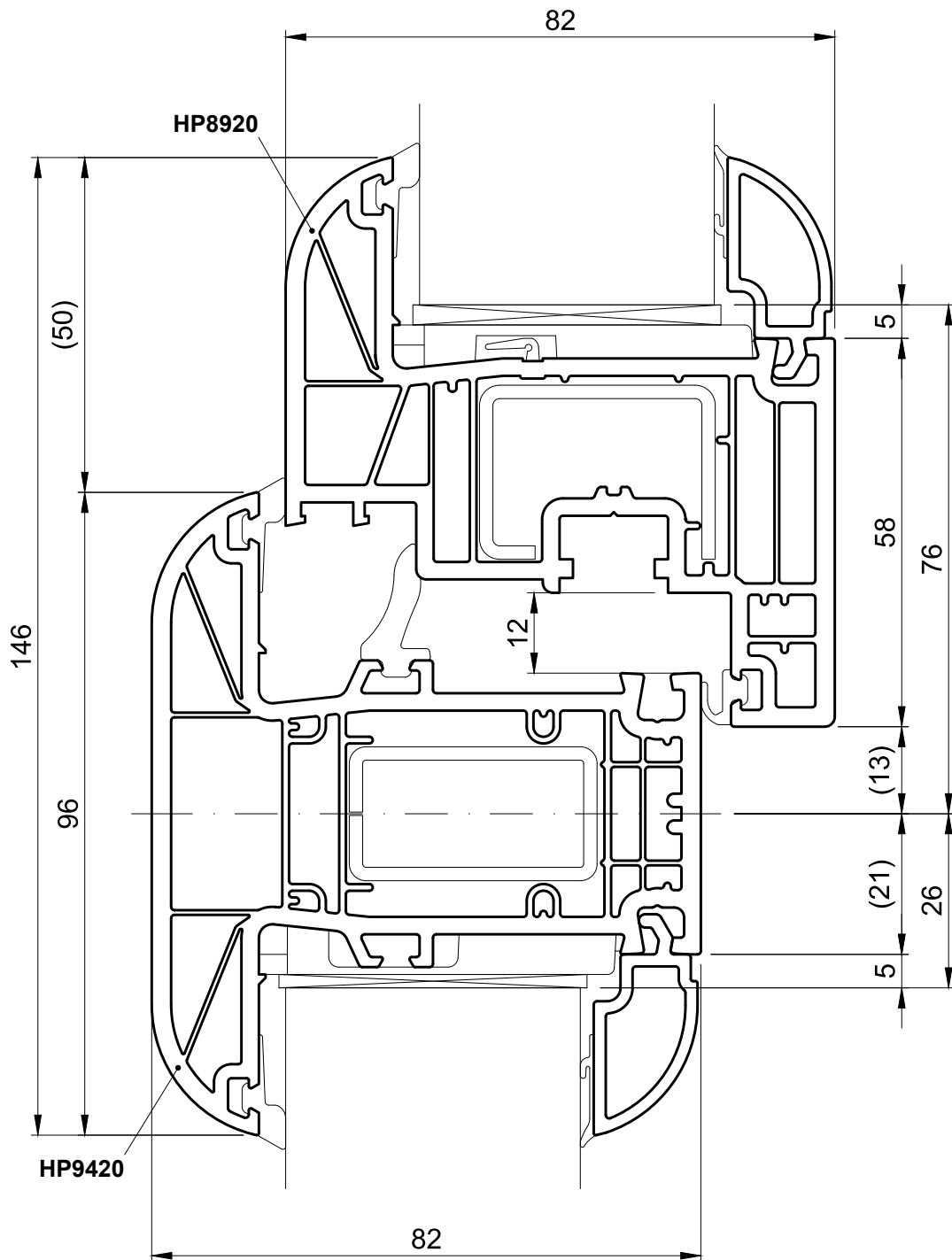

Sash  
HP8920

Fixed mullion  
HO8320

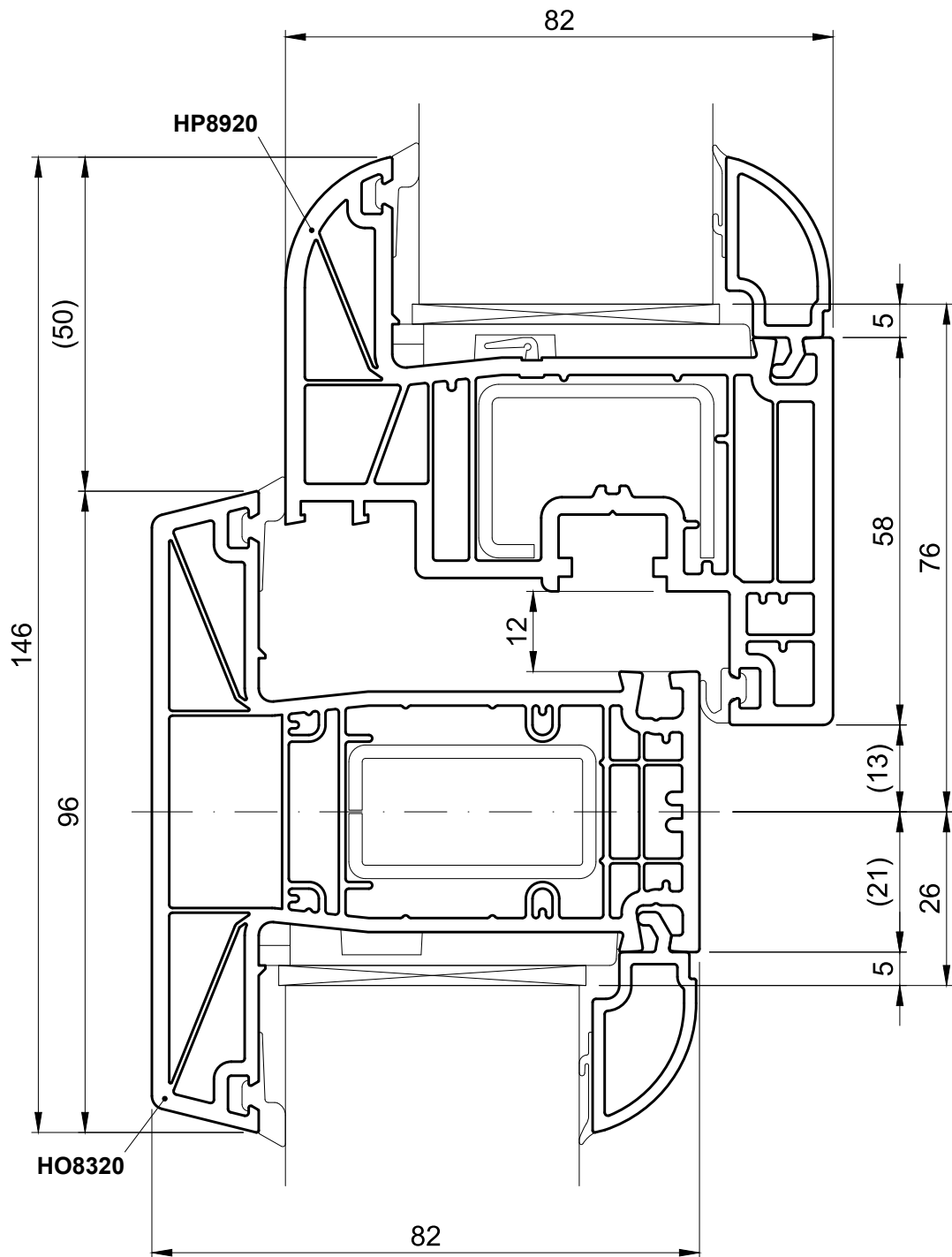

Sash  
HP8920

Fixed mullion  
HO8310

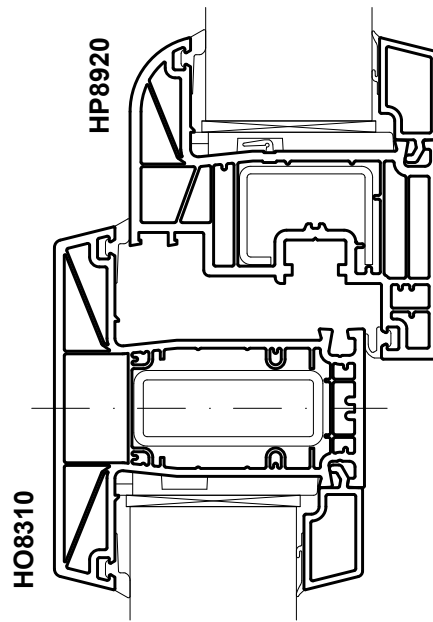

Sash  
HP8920

Fixed mullion  
HP9420

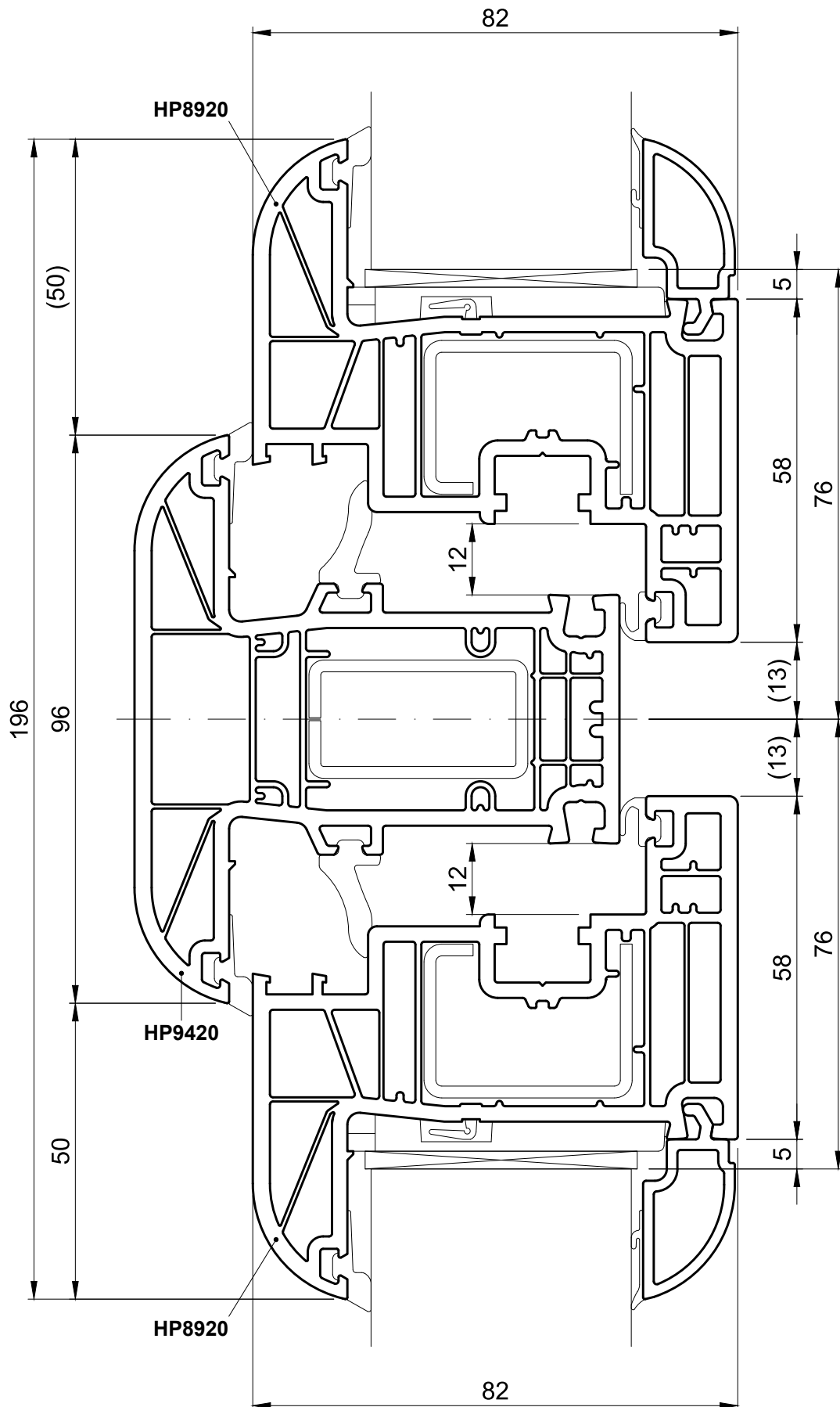

Sash  
HP8920

Fixed mullion  
HO8320

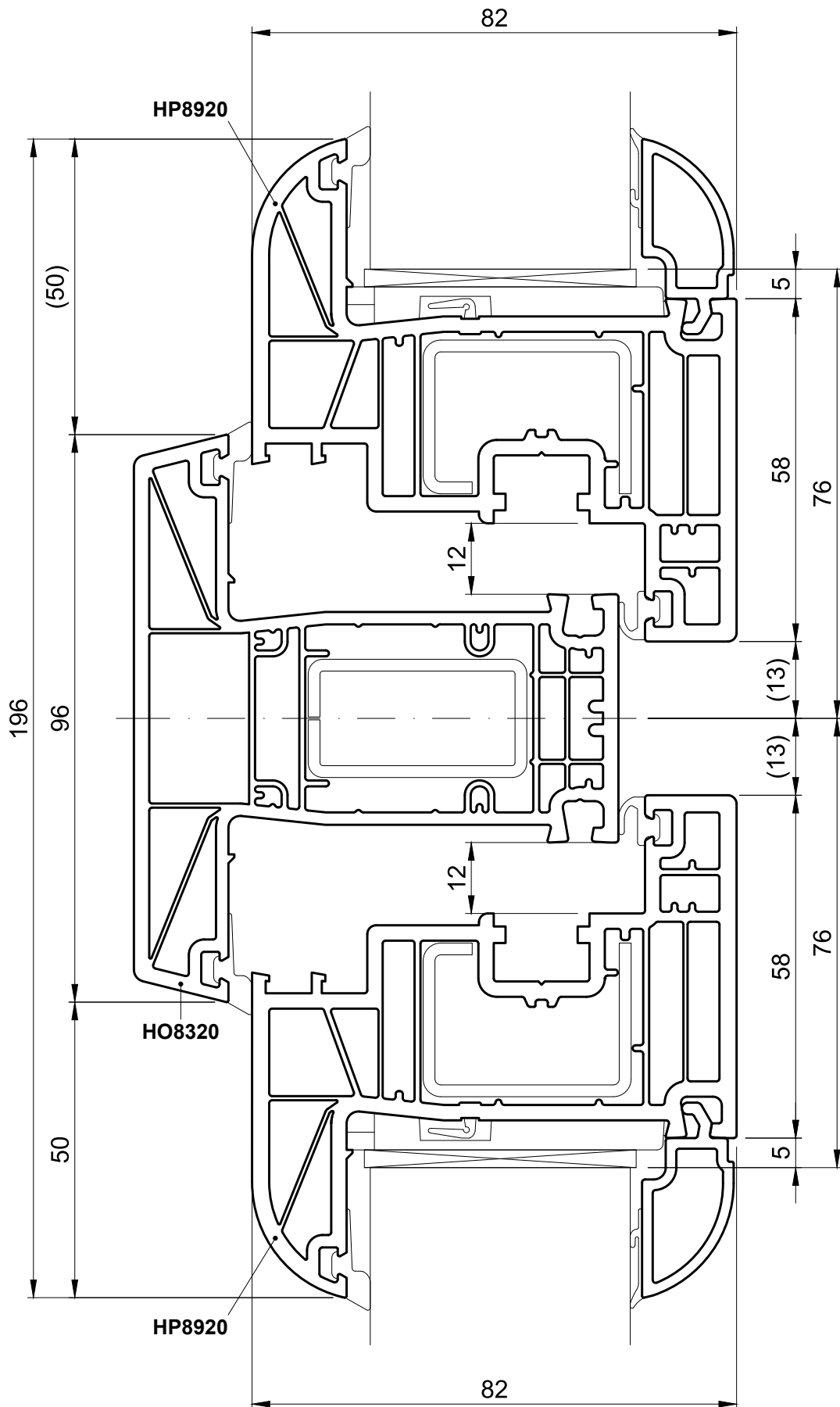

Sash  
**HP8920**

Fixed mullion  
**HO8310**

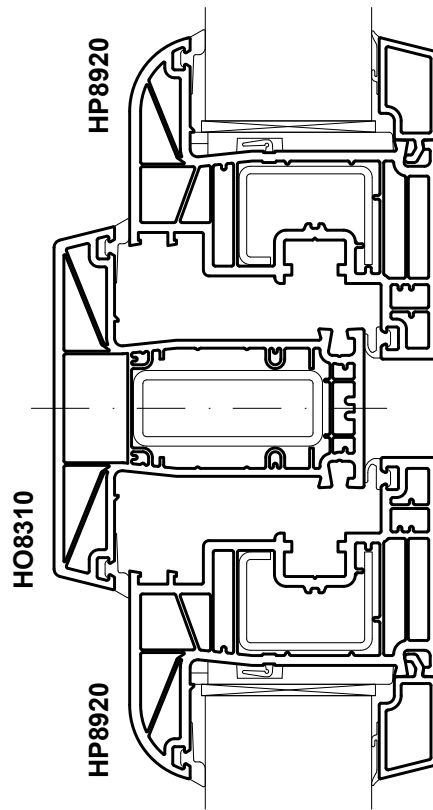

Sash  
HO8530

Fixed mullion  
HO9320

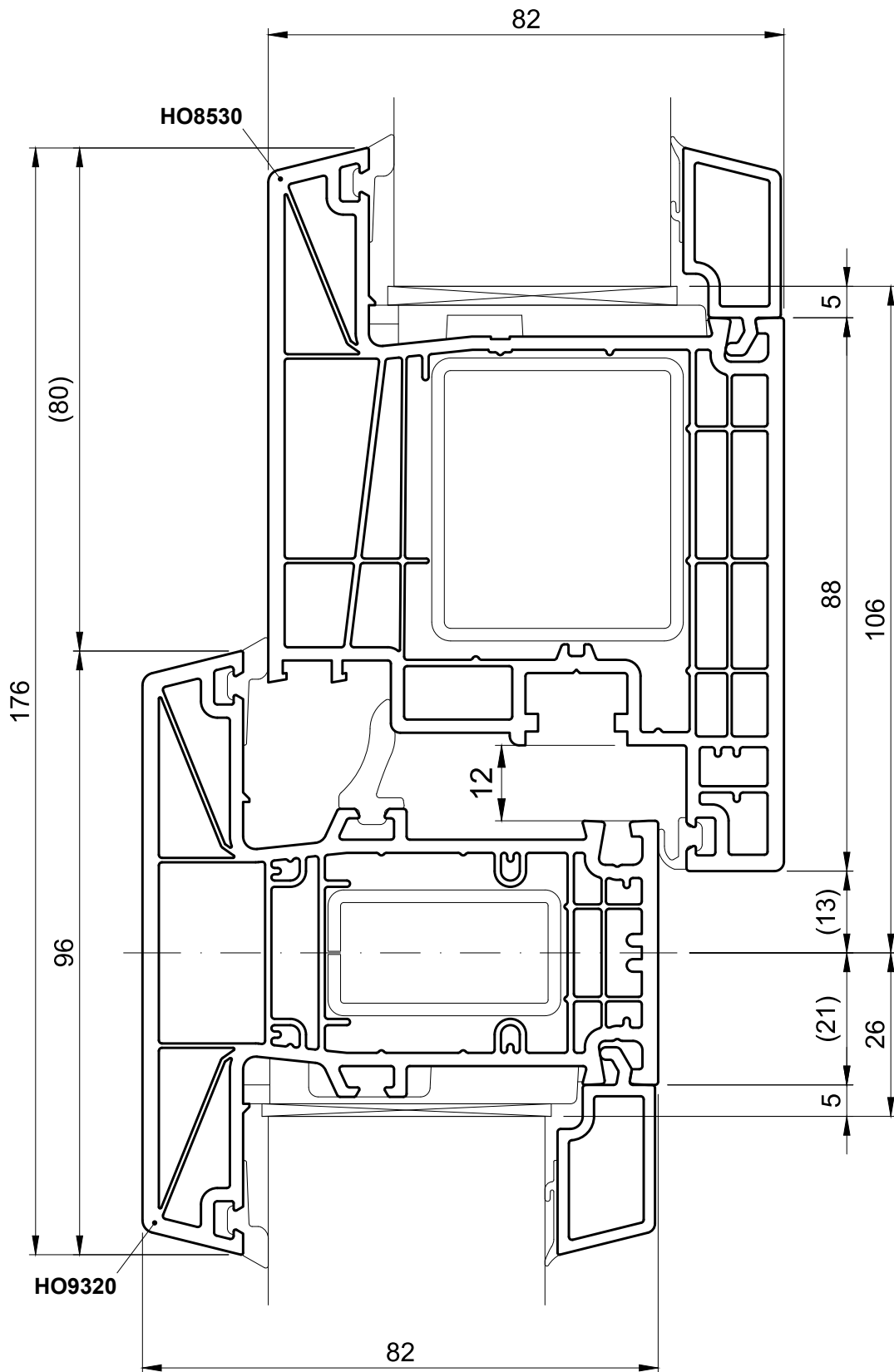

Sash  
HO8530

Fixed mullion  
HO9310, HO8320, HO8310

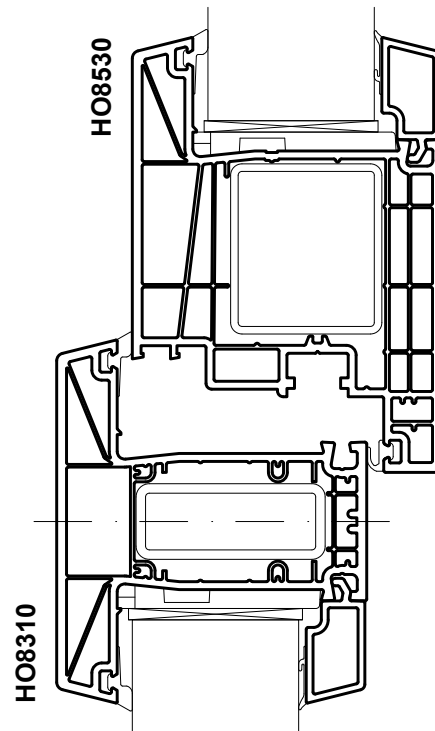
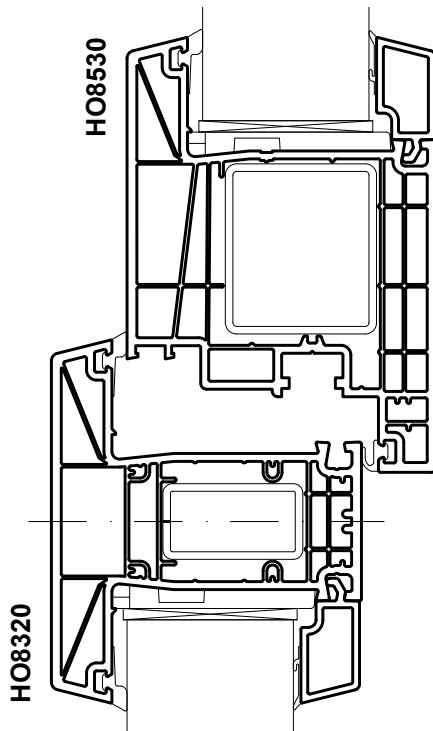
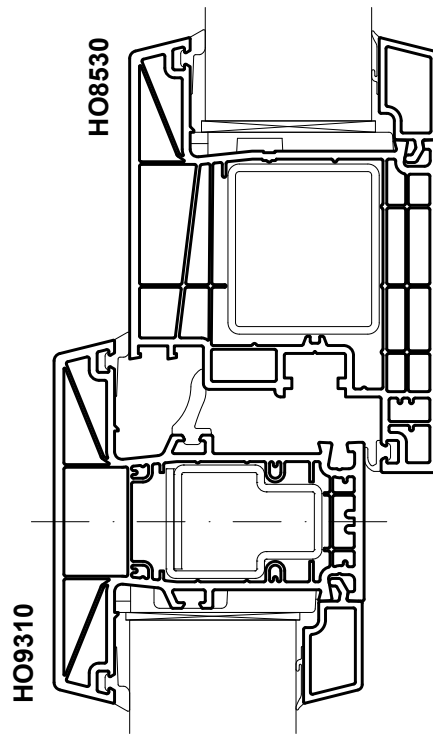

Sash  
HO8530

Fixed mullion  
HO9340

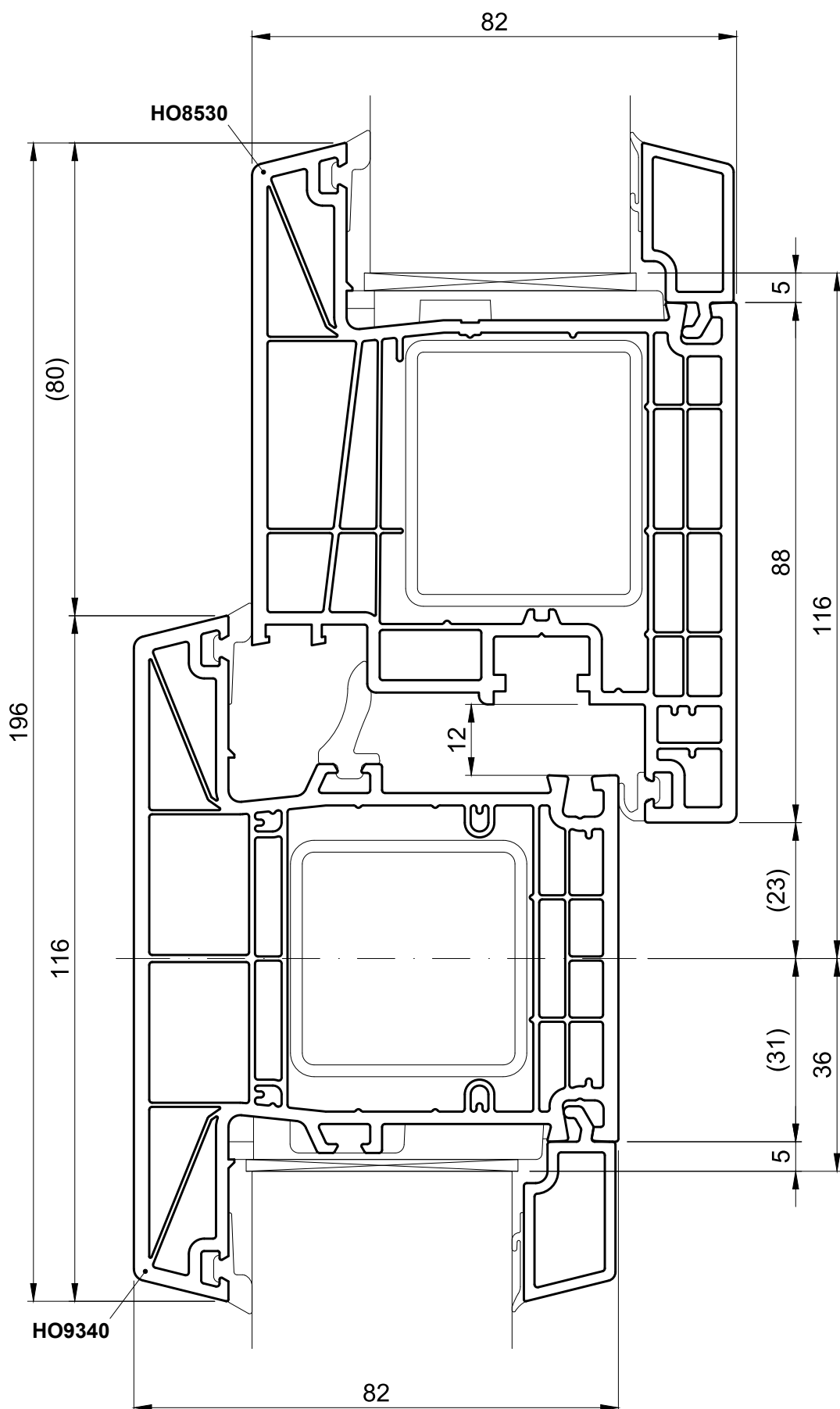

Sash  
**HO8530**

Fixed mullion  
**HO9330**

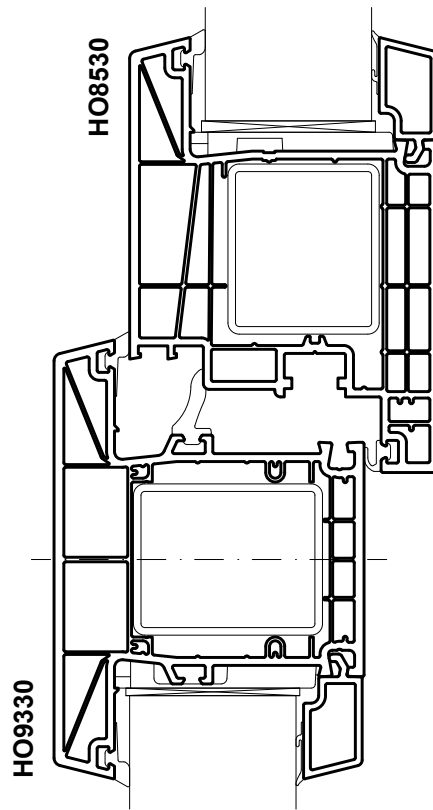

Sash  
HO8530

Fixed mullion  
HO9320, HO9310

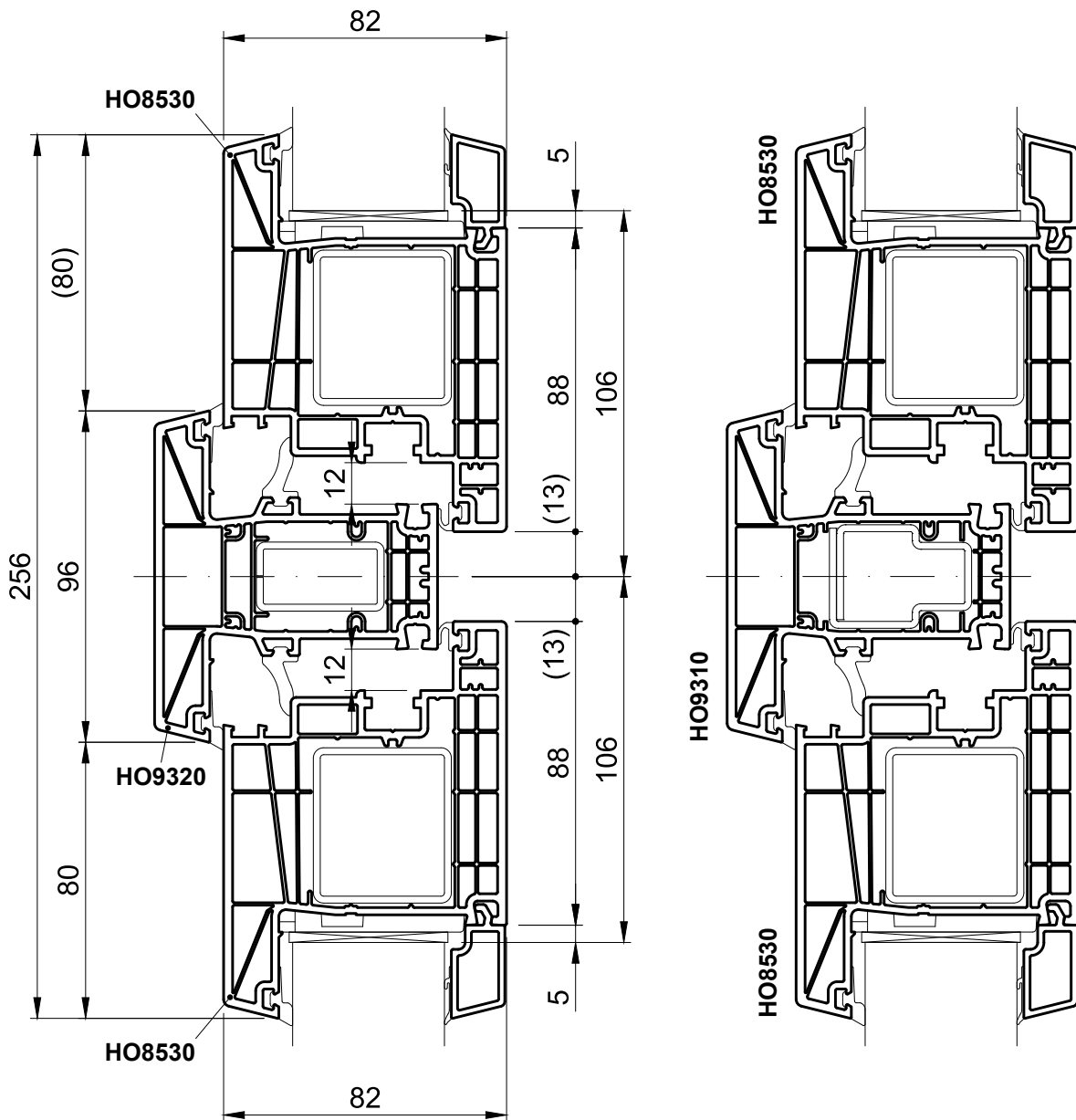

Sash  
HO8530

Fixed mullion  
HO8320, HO8310

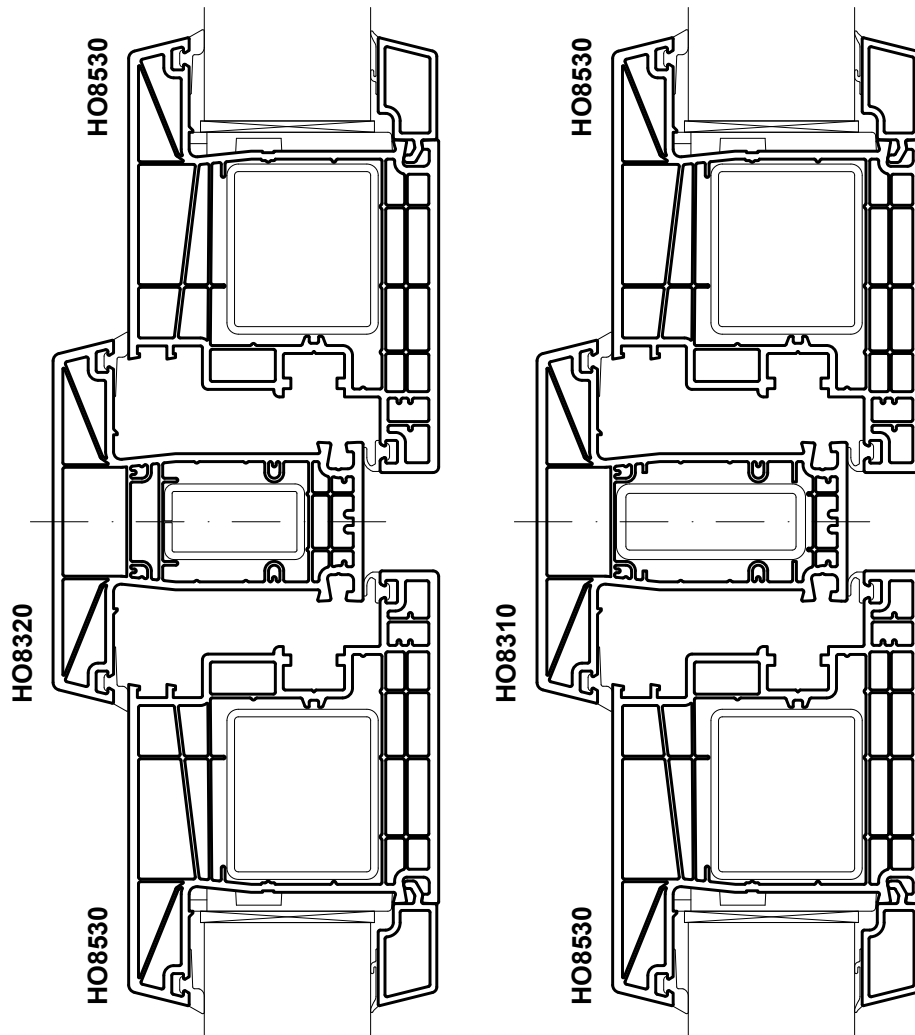

Sash  
HO8530

Fixed mullion  
HO9340, HO9330

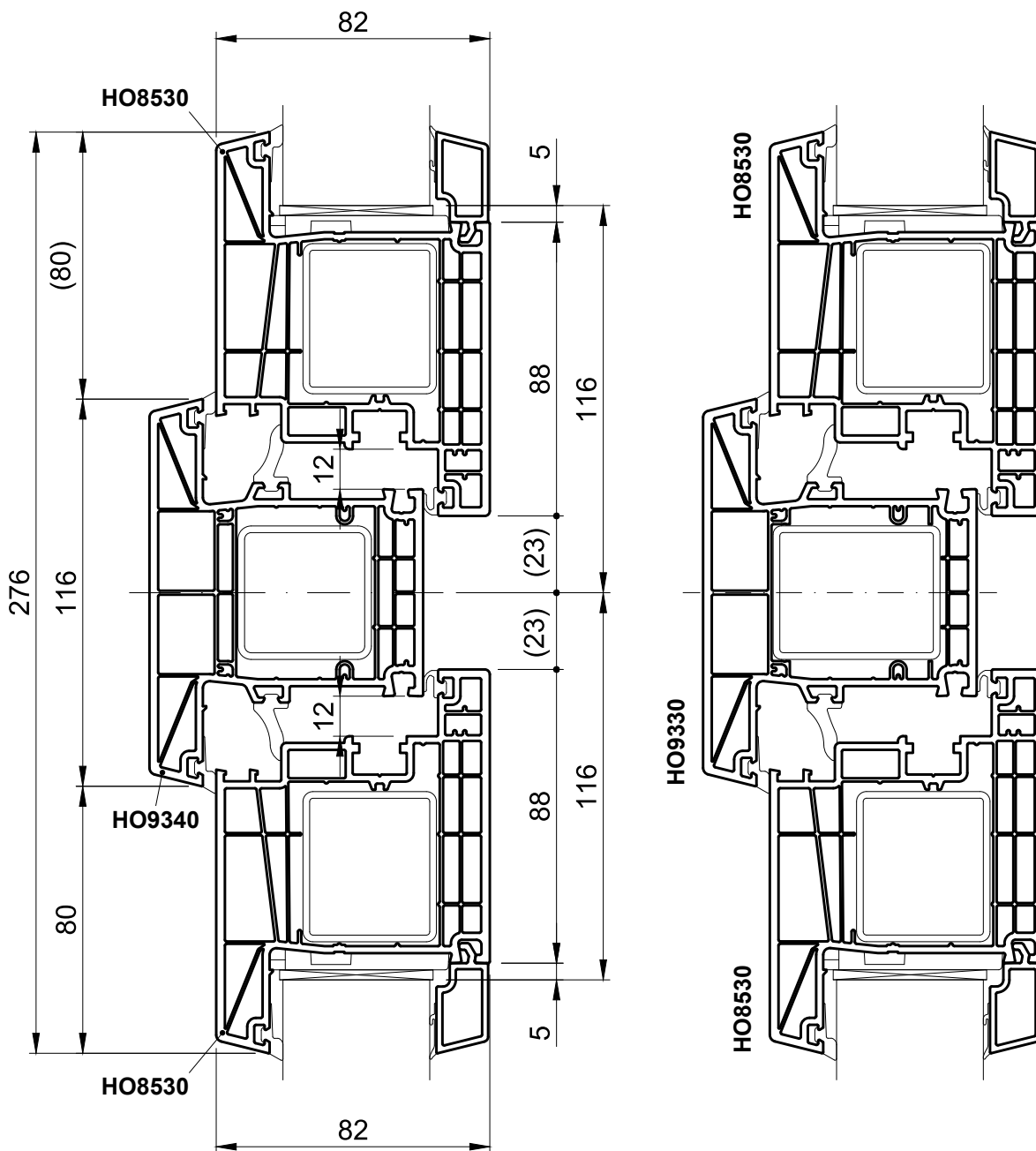

Sash  
HP8930

Fixed mullion  
HP9420

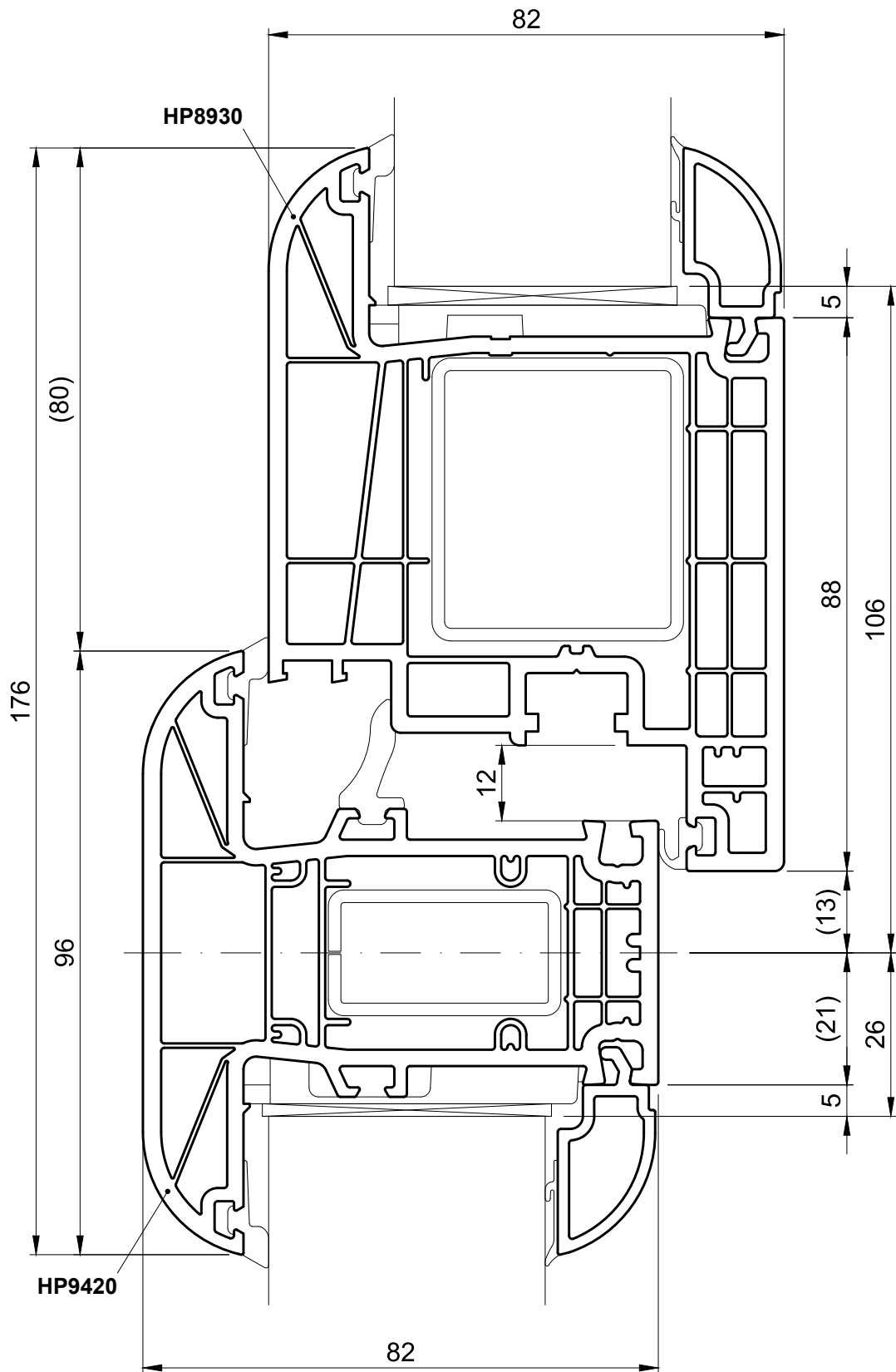

Sash  
HP8930

Fixed mullion  
HO8320

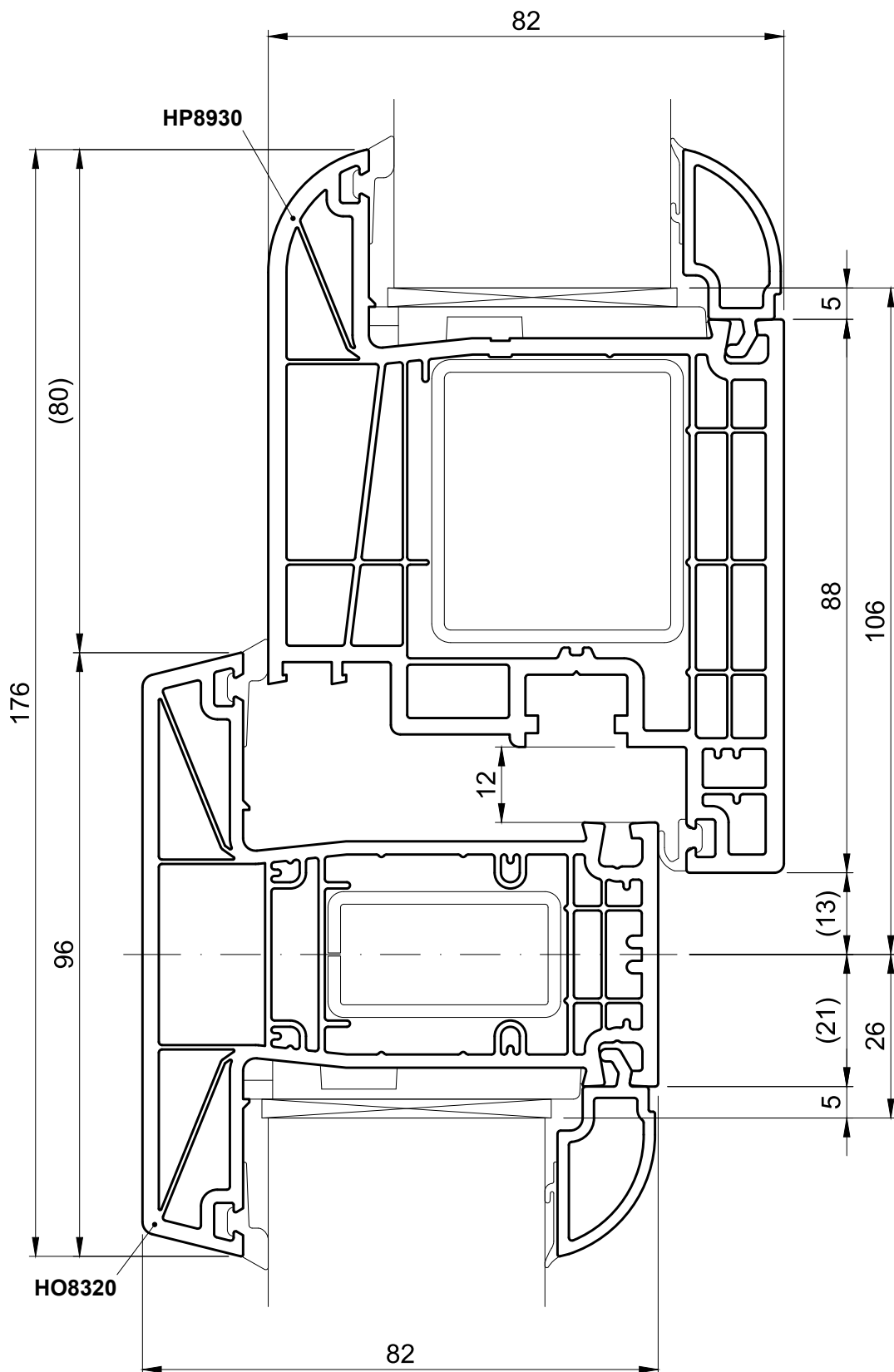

Sash  
**HP8930**

Fixed mullion  
**HO8310**

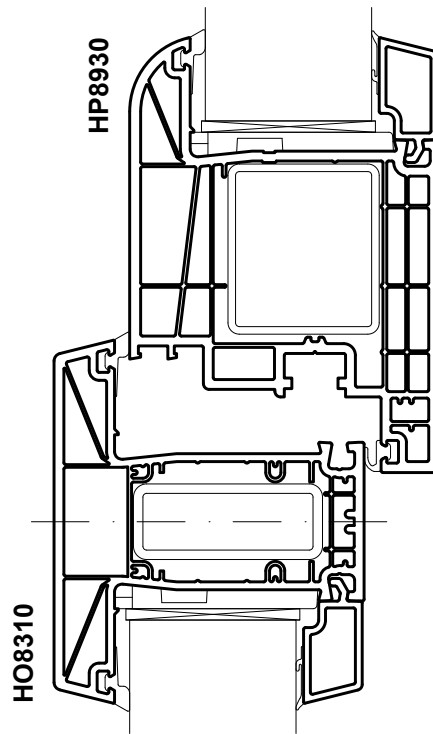

Sash  
HP8930

Fixed mullion  
HP9420

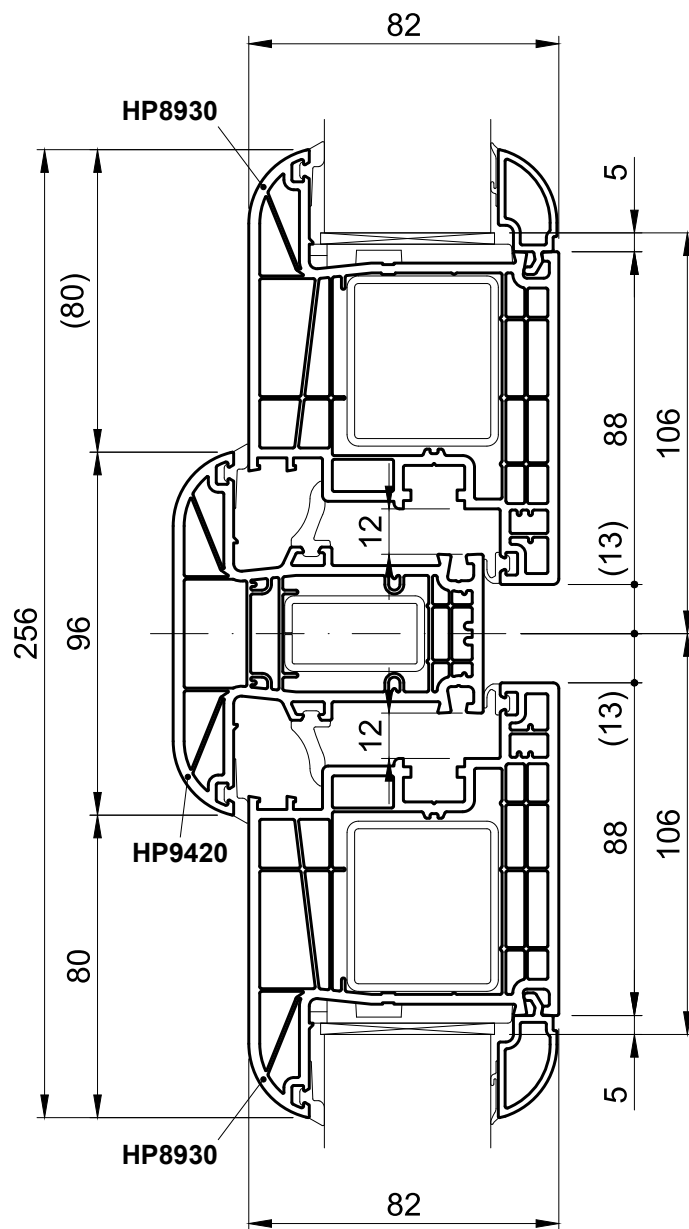

Sash  
HP8930

Fixed mullion  
HO8320, HO8310

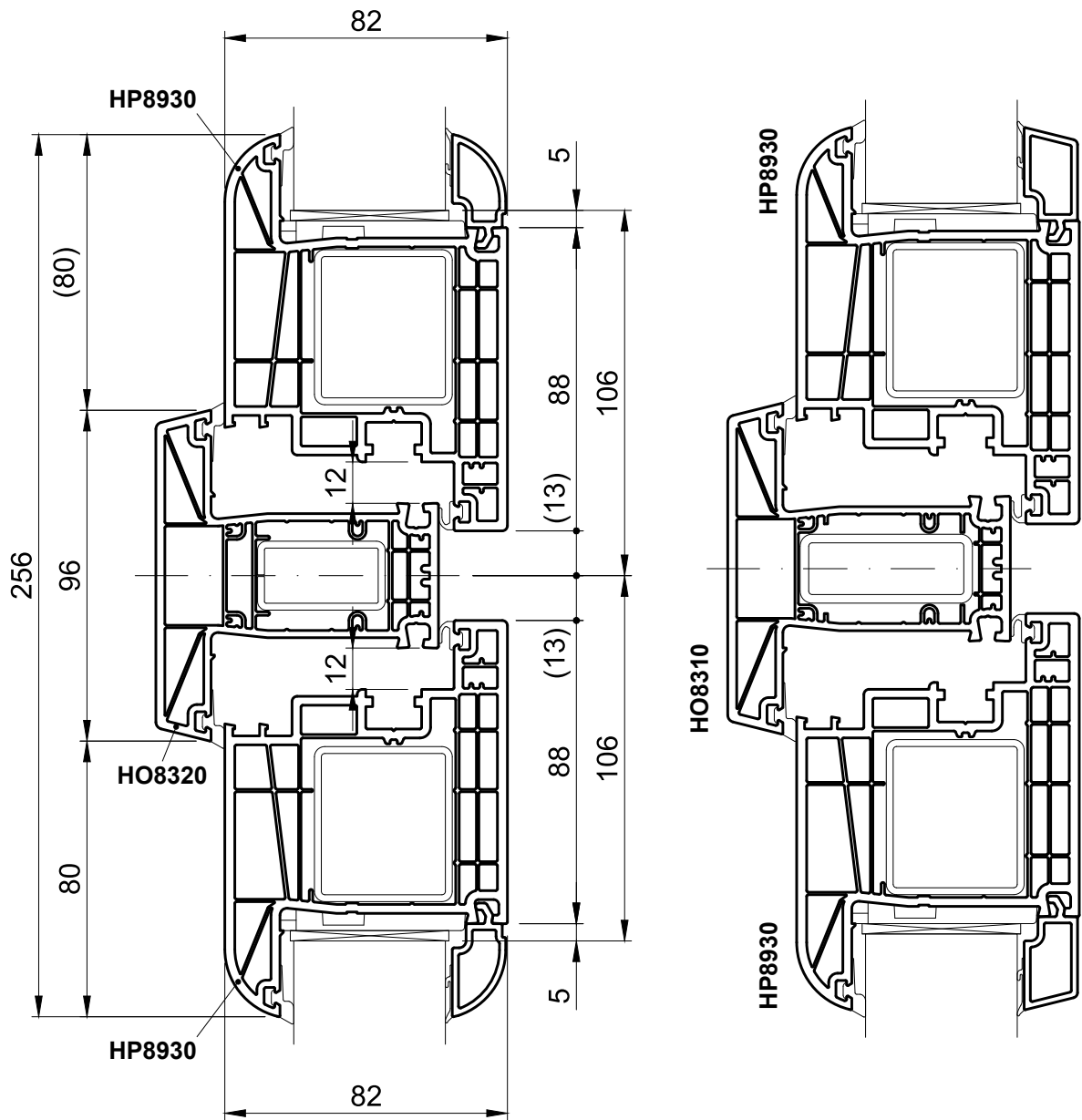

Sash  
HP8930

Fixed mullion  
HO8310

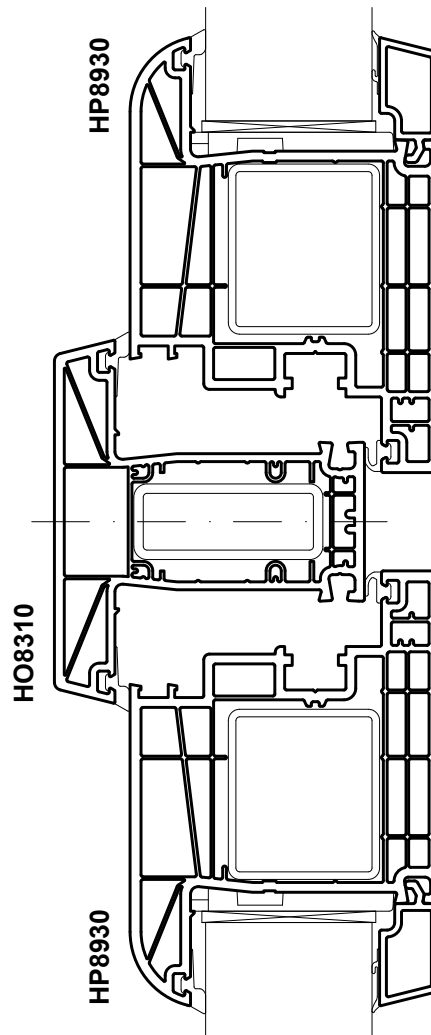

Sash  
HO8540

Fixed mullion  
HO9320, HO9310

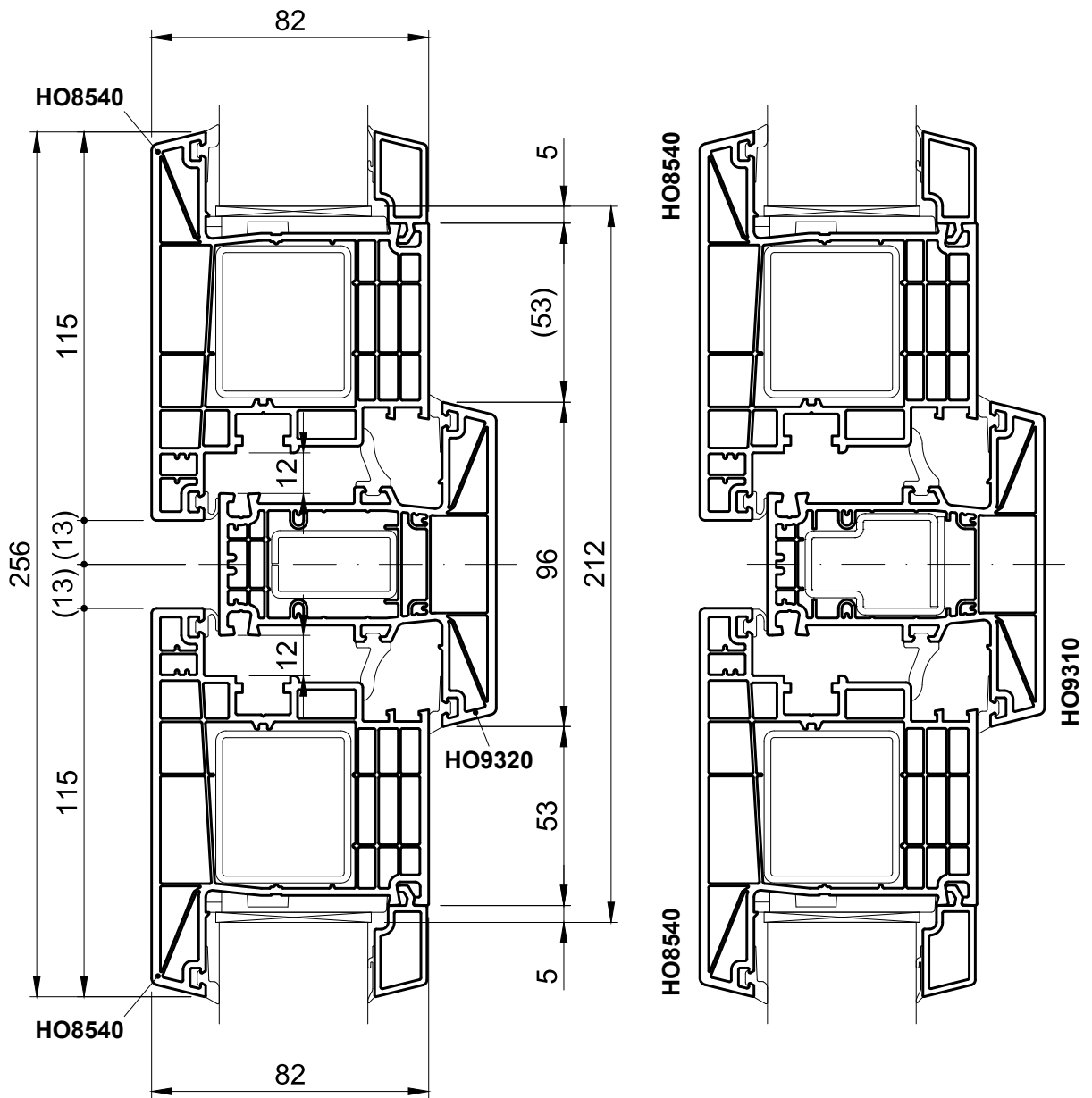

Sash  
HO8540

Fixed mullion  
HO8320, HO8310

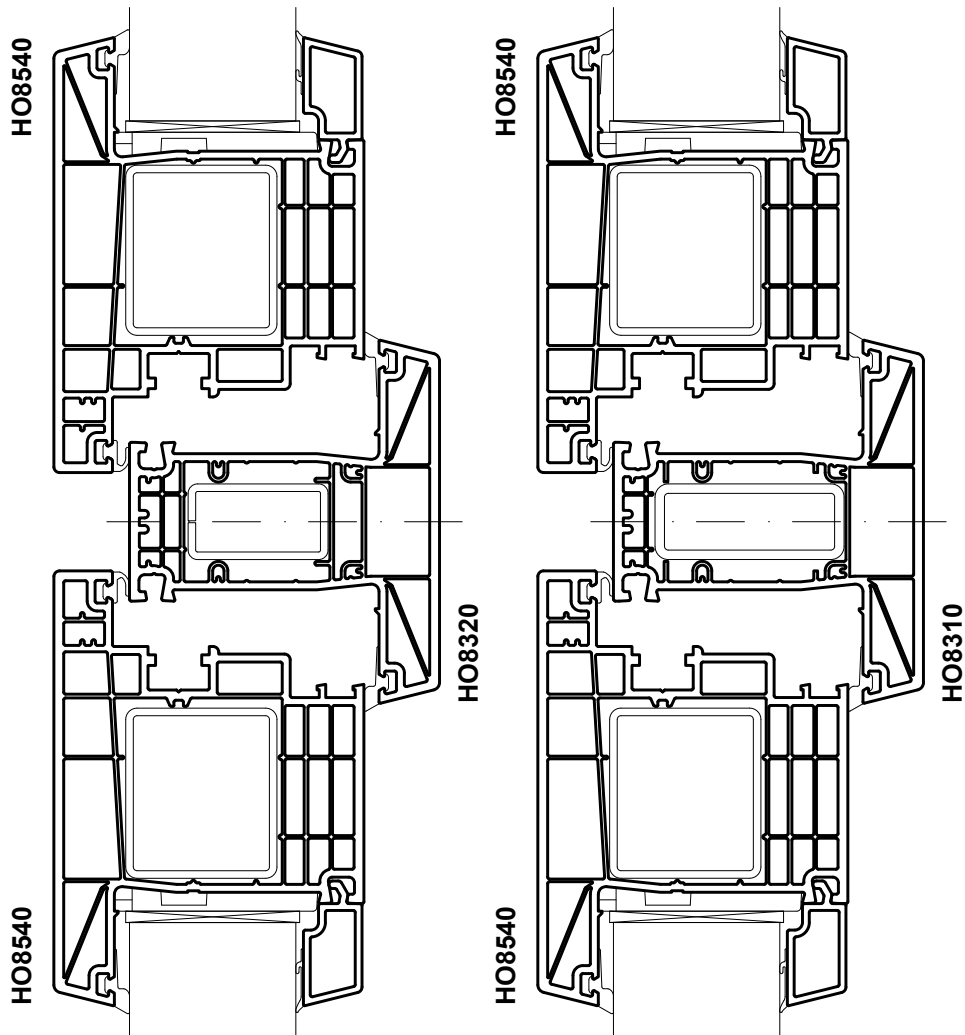

Sash  
HO8540

Fixed mullion  
HO9340, HO9330

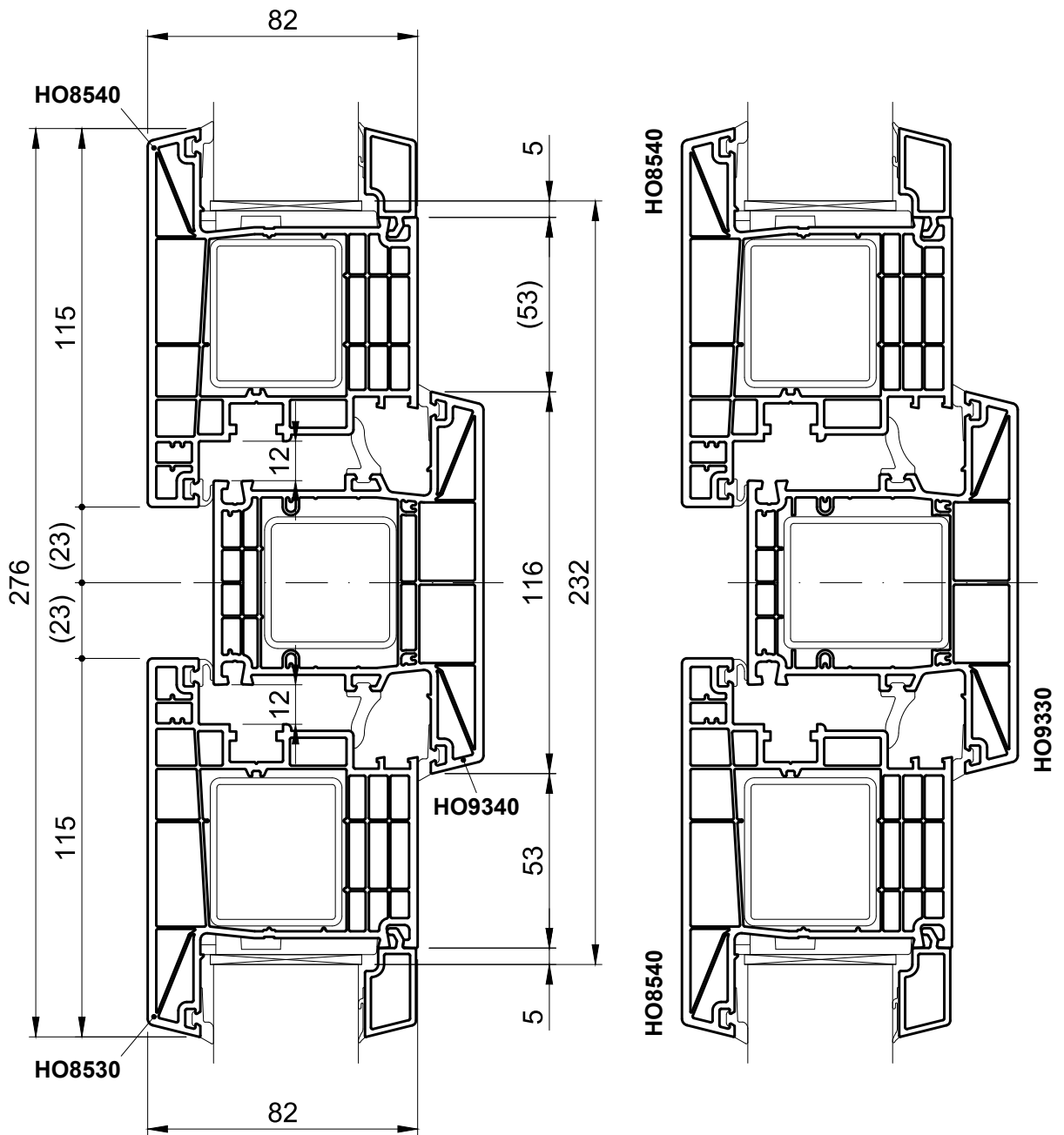

Sash  
HP8550

Fixed mullion  
HO9320

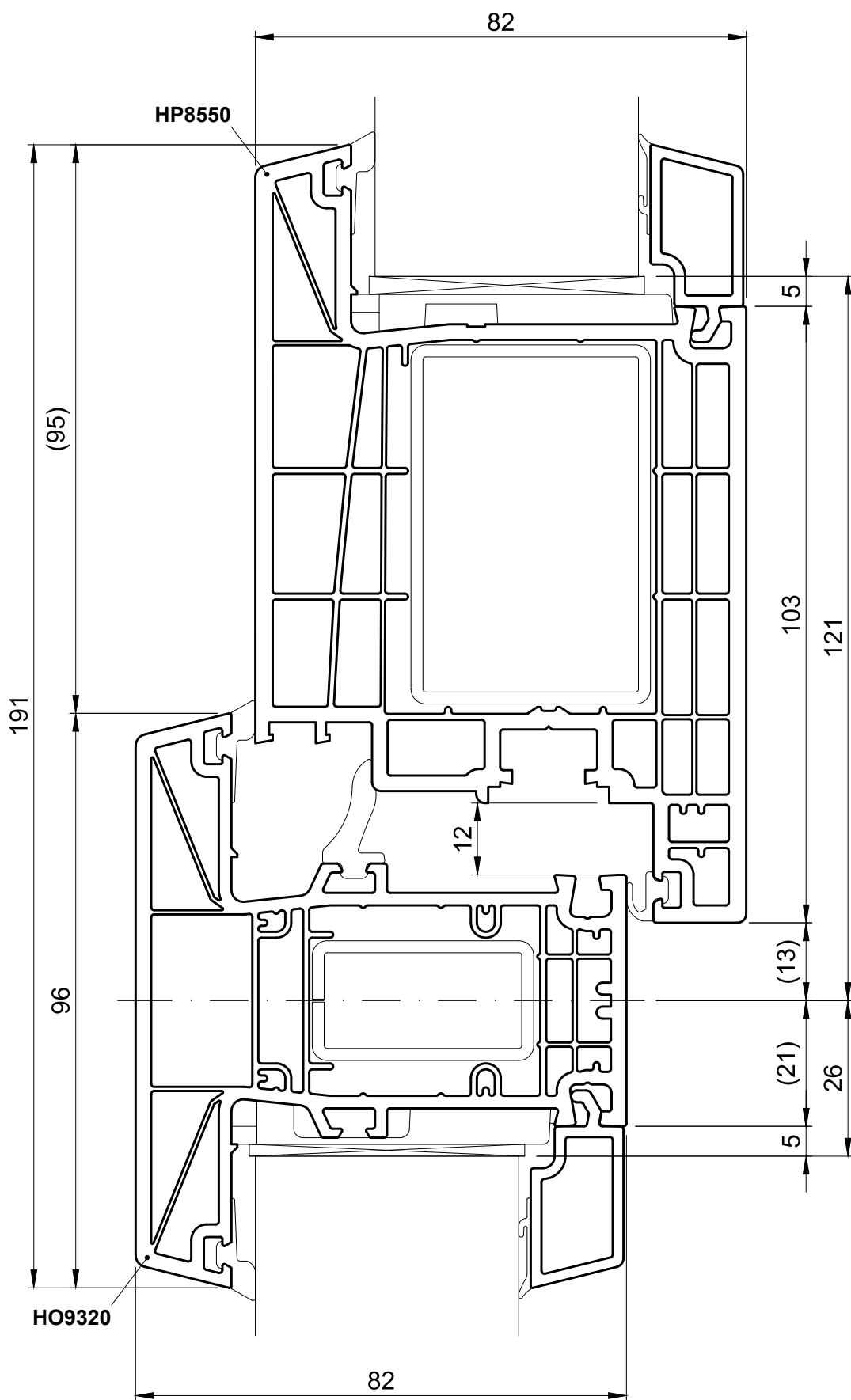

Sash  
HP8550

Fixed mullion  
HO9310, HO8320, HO8310

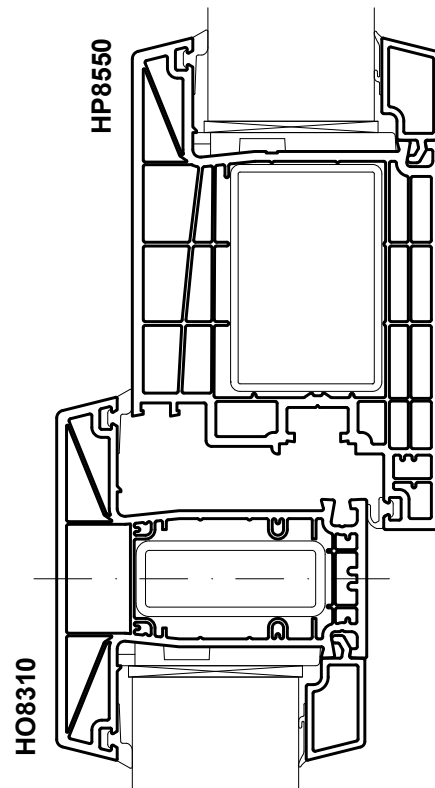
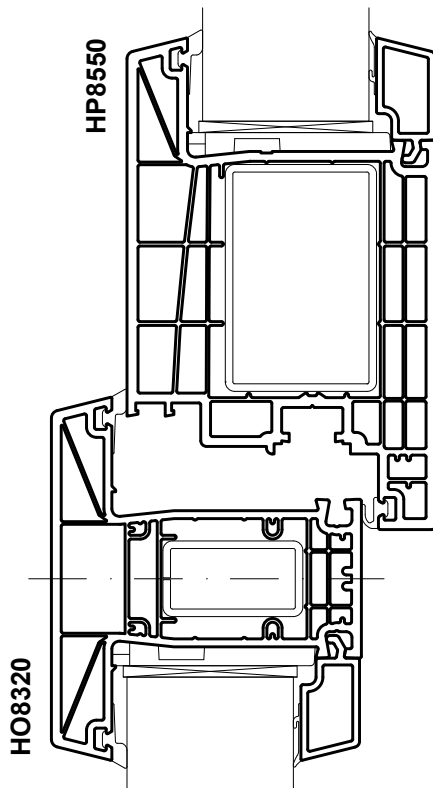
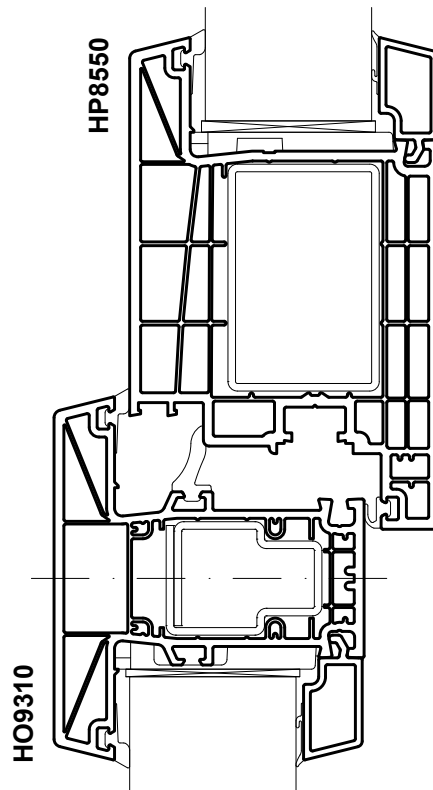

Sash  
HP8550

Fixed mullion  
HO9340

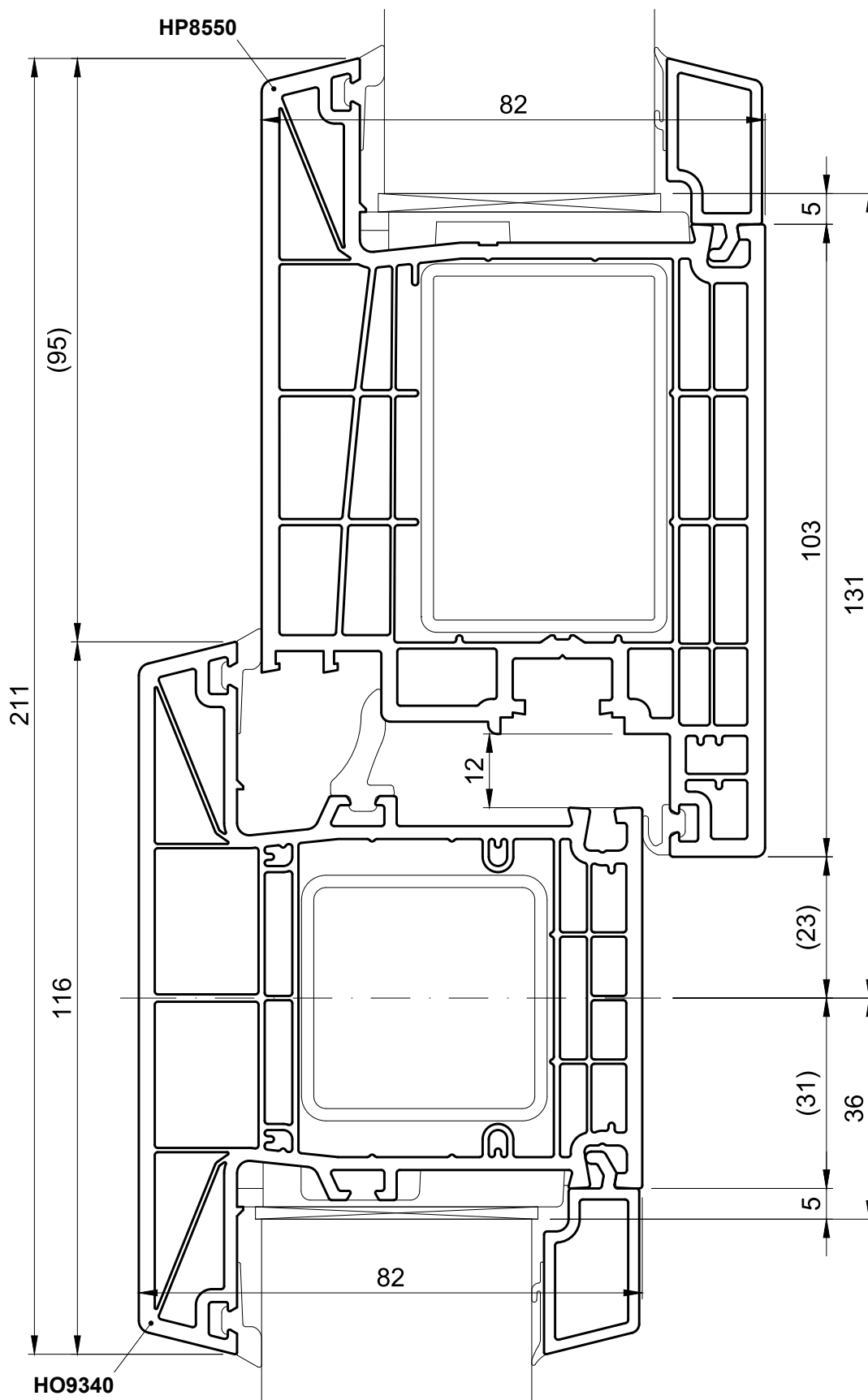

Sash  
**HP8550**

Fixed mullion  
**HO9330**

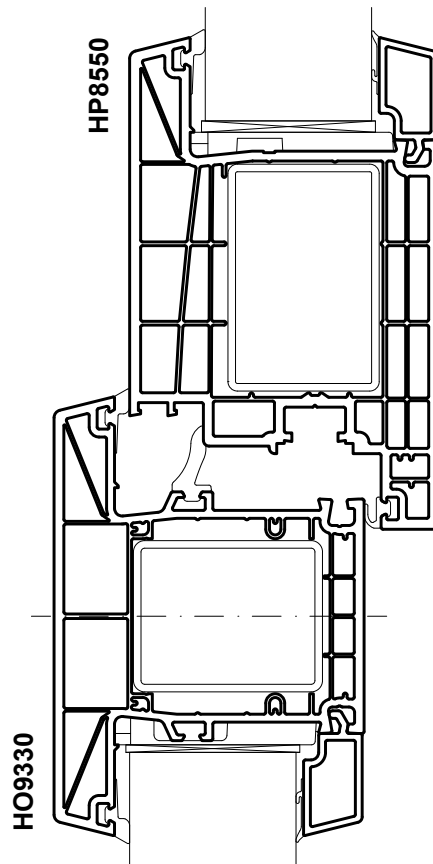

Sash  
HP8550

Fixed mullion  
HO9320, HO9310

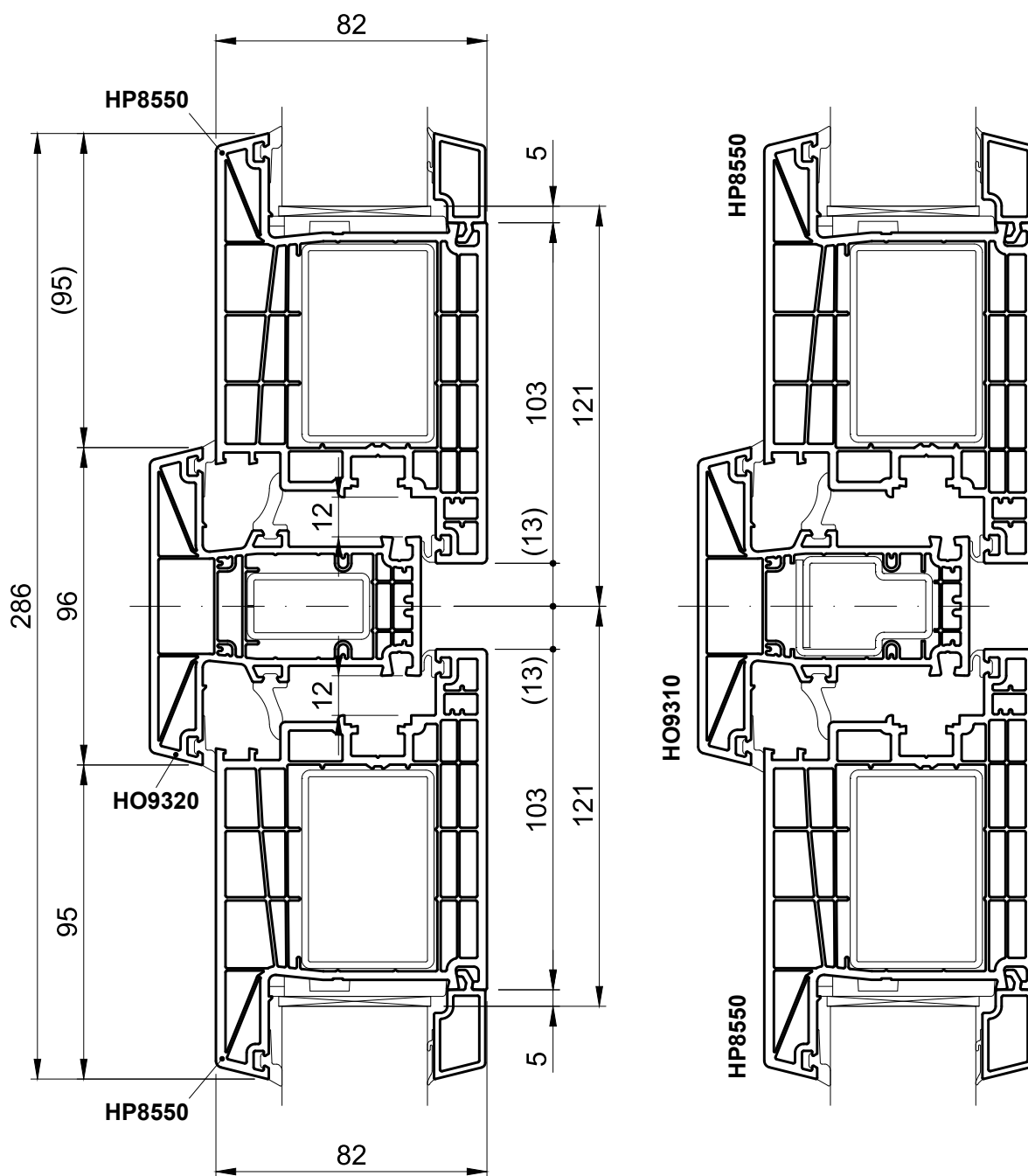

Sash  
HP8550

Fixed mullion  
HO8320, HO8310

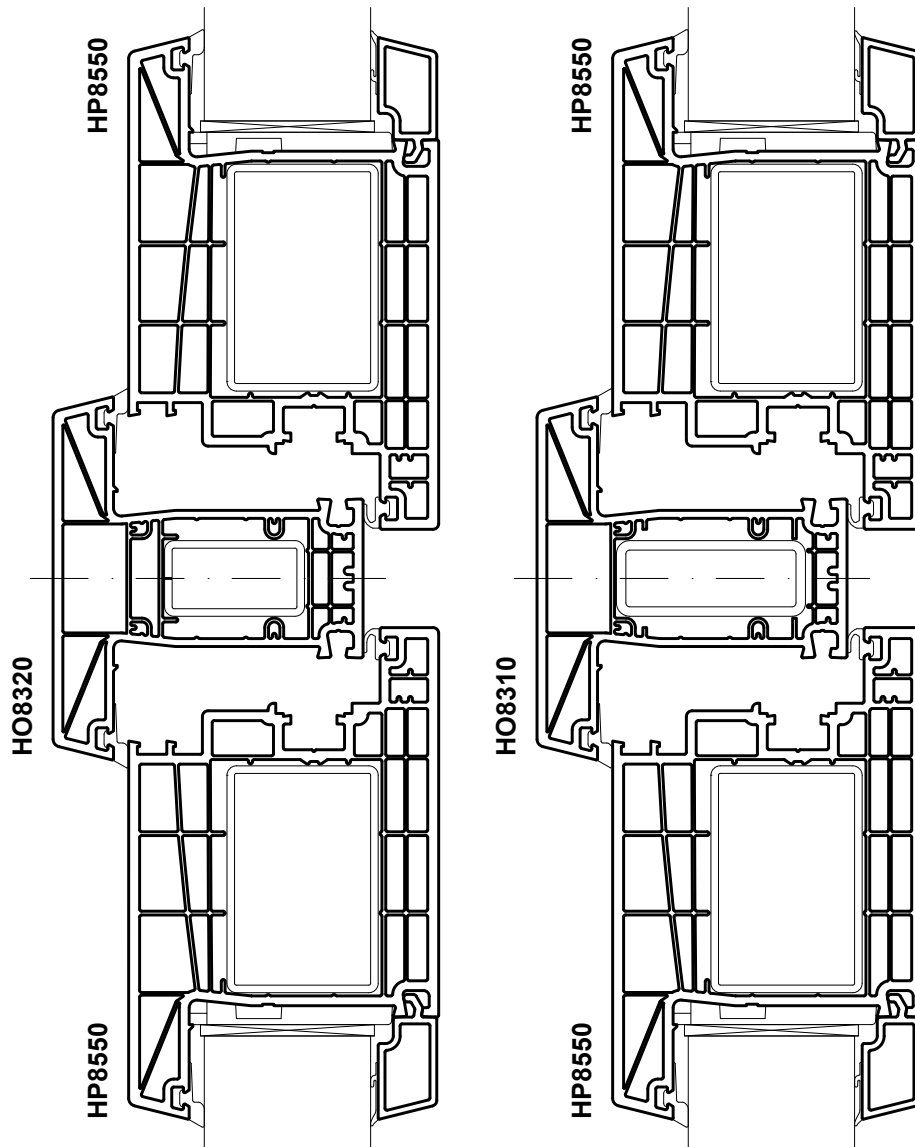

Sash  
HP8550

Fixed mullion  
HO9340, HO9330

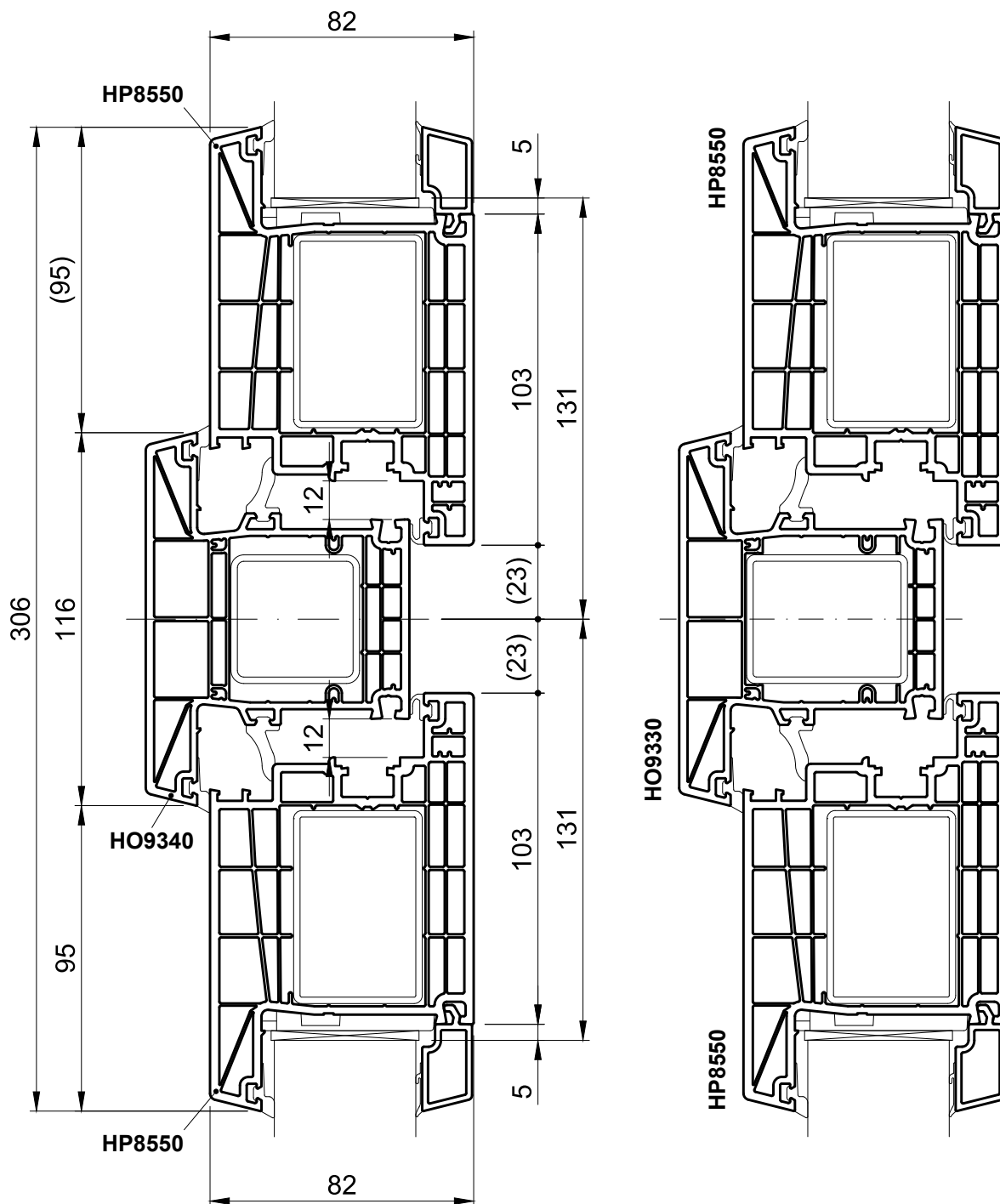

Sash  
HP8560

Fixed mullion  
HO9320, HO9310

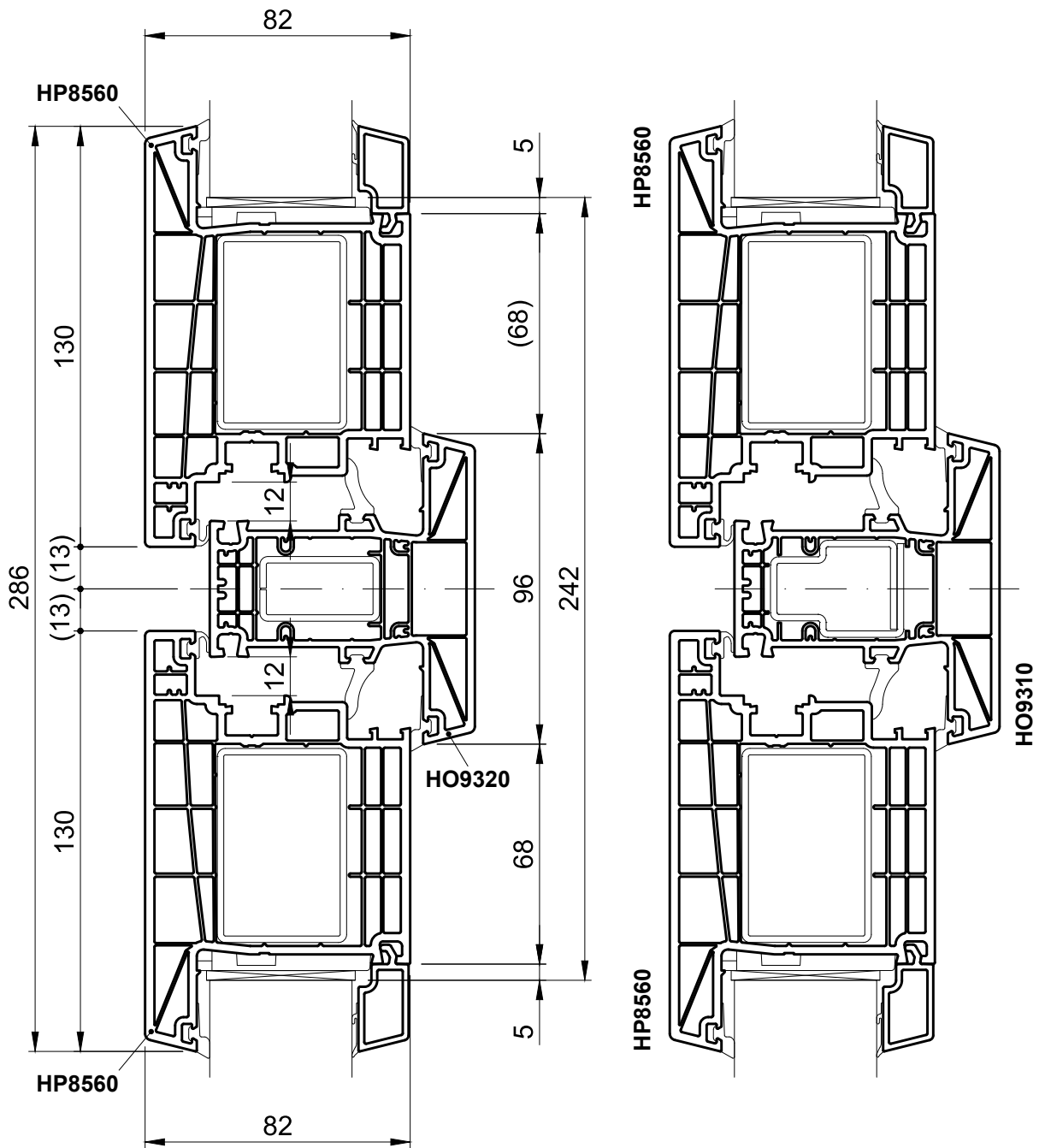

Sash  
HP8560

Fixed mullion  
HO8320, HO8310

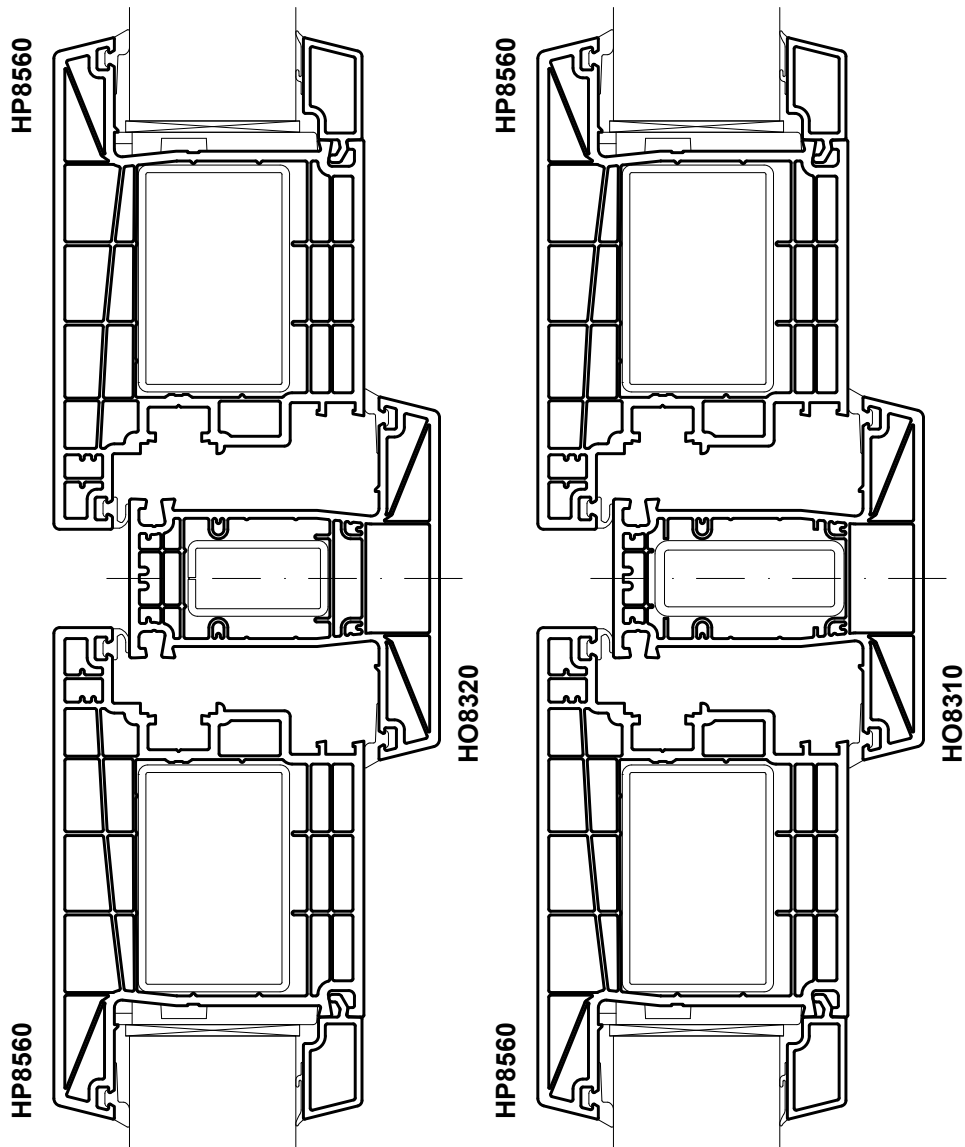

Sash  
HP8560

Fixed mullion  
HO9340, HO9330

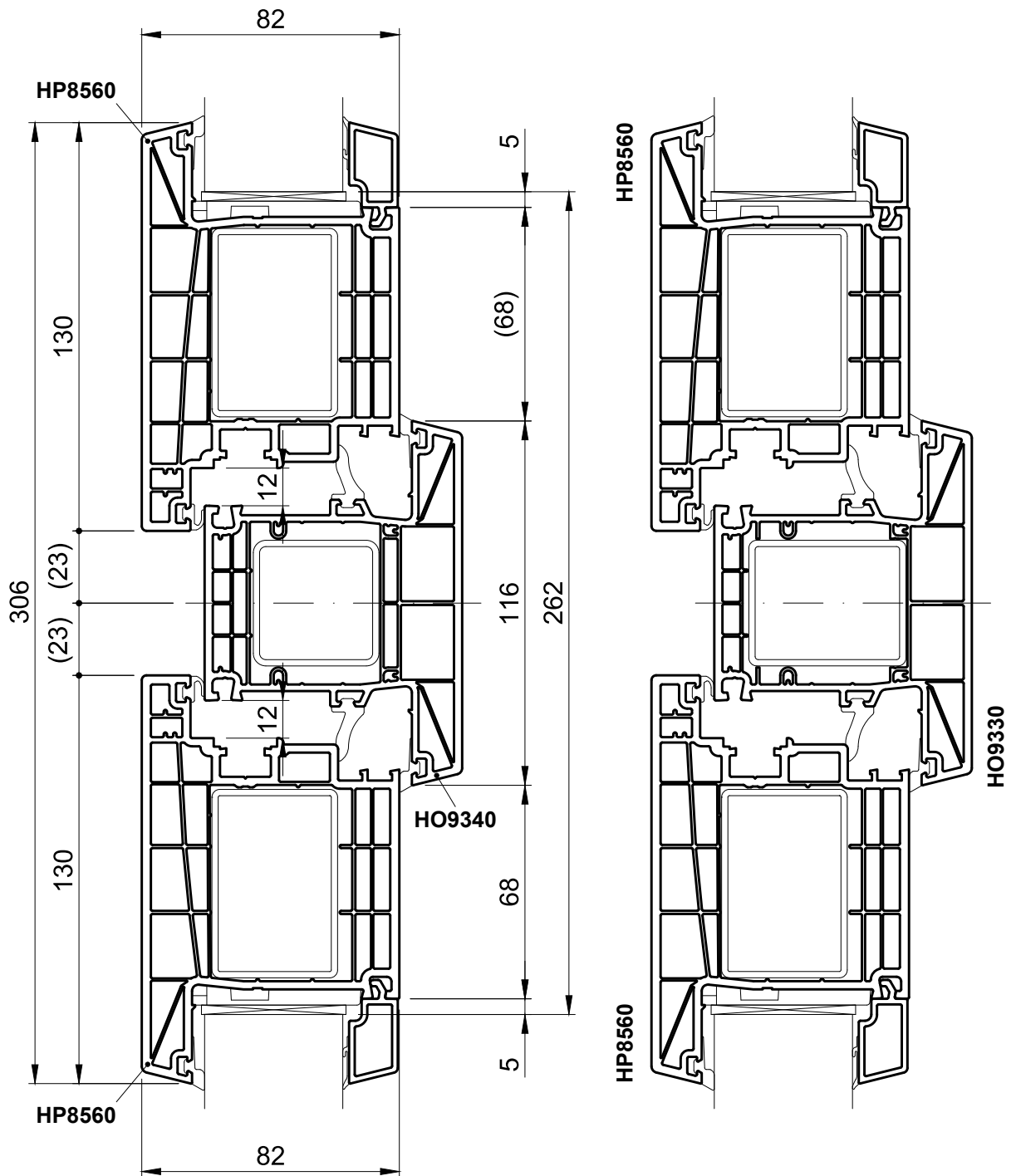

Sash  
HO8510

Right-angled profile  
HO9810

Clearance

Sash width		Faceplate height	
HO9020, HO9021	(RAM/2) – 33 mm	HO9810	FAM – 84 mm
HO9030	(RAM/2) – 43 mm		
HO9050	(RAM/2) – 63 mm	Faceplate cap ZS9811	
HO9100	(RAM/2) – 93 mm		
HO9110	(RAM/2) – 68 mm		
HO9120	(RAM/2) – 57 mm		

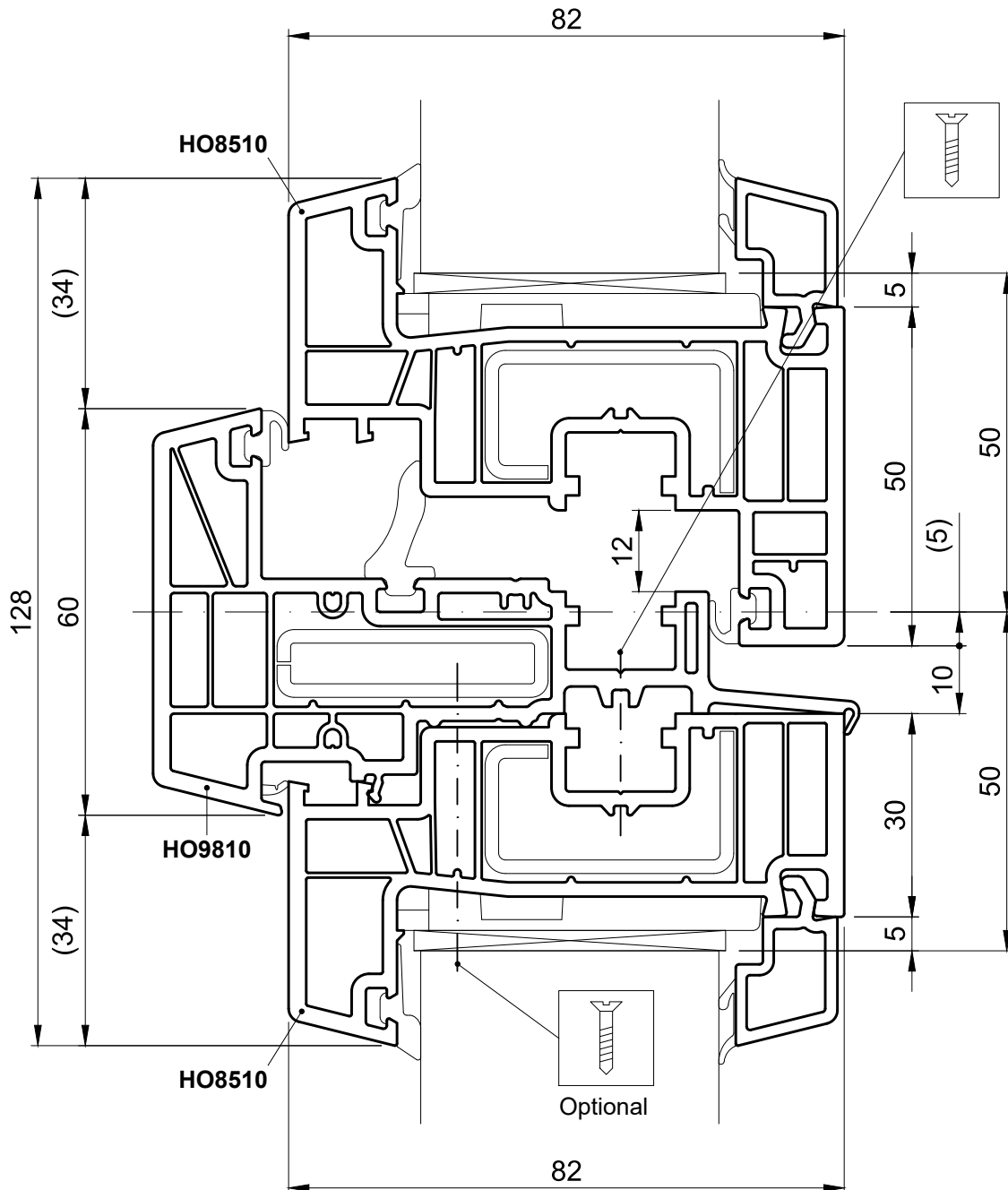

Sash profile	Faceplate, right angled	French window sash	Inner strike plate
<b>HO8520</b>	<b>HO9820</b>	<b>HO8570</b>	<b>NP8250</b>

**Clearance**

Sash width		Faceplate height	
HO9020, HO9021	(RAM/2) – 24 mm	Faceplate cap ZS9820	FAM – 40 mm
HO9030	(RAM/2) – 34 mm		
HO9050	(RAM/2) – 54 mm		
HO9100	(RAM/2) – 84 mm		
HO9110	(RAM/2) – 59 mm		
HO9120	(RAM/2) – 48 mm		

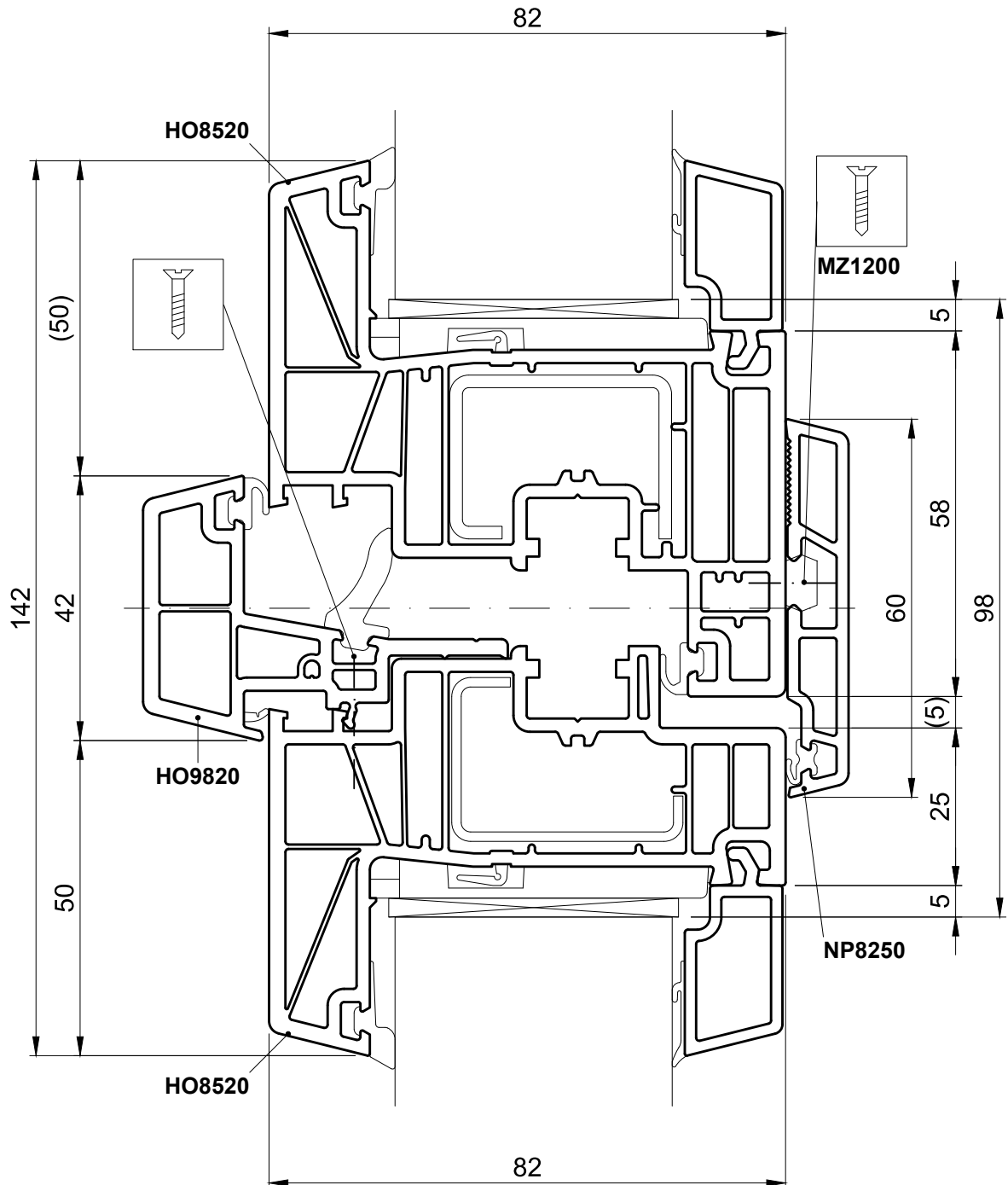

Sash  
HO8520

Right-angled profile  
HO9810

Clearance

Sash width		Faceplate height	
HO9020, HO9021	(RAM/2) – 33 mm	HO9810	FAM – 84 mm
HO9030	(RAM/2) – 43 mm		
HO9050	(RAM/2) – 63 mm	Faceplate cap ZS9811	
HO9100	(RAM/2) – 93 mm		
HO9110	(RAM/2) – 68 mm		
HO9120	(RAM/2) – 57 mm		

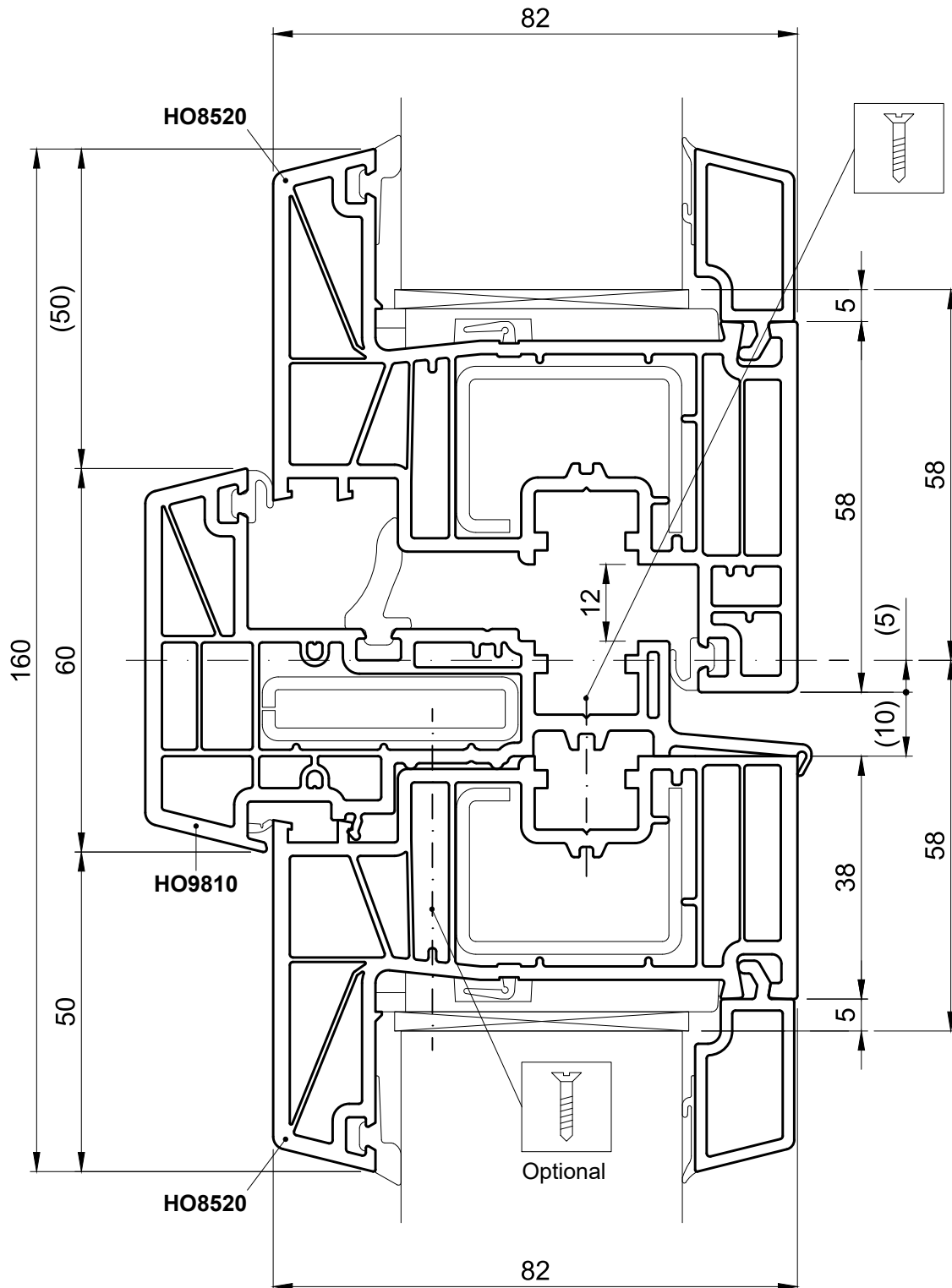

Sash  
**HO8520**

Right-angled profile  
**HO9800**

**Clearance**

Sash width		Faceplate height	
HO9020, HO9021	(RAM/2) – 43 mm	HO9800	FAM – 84 mm
HO9030	(RAM/2) – 53 mm		
HO9050	(RAM/2) – 73 mm		
HO9100	(RAM/2) – 103 mm	Faceplate cap ZS9801	
HO9110	(RAM/2) – 78 mm		
HO9120	(RAM/2) – 67 mm		

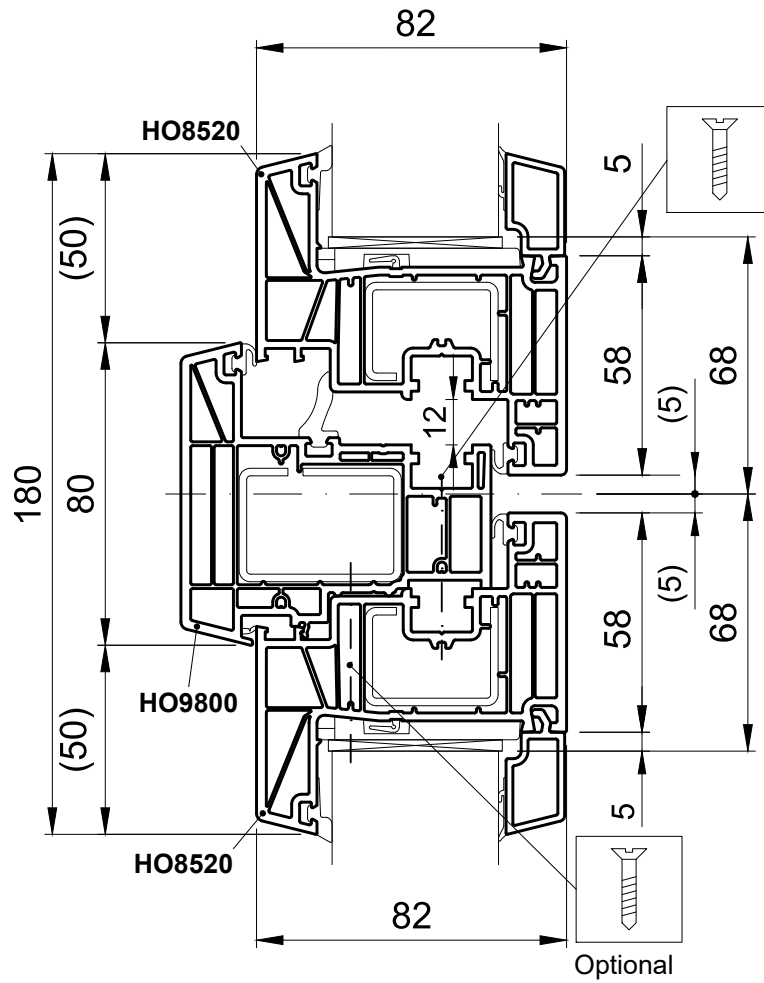

Sash  
HO8520

Right-angled profile  
HO8800

Clearance

Sash width		Faceplate height	
HO8020, HO8021	(RAM/2) – 43 mm	HO8800	FAM – 84 mm
HO8030	(RAM/2) – 53 mm	Faceplate cap ZS8801	

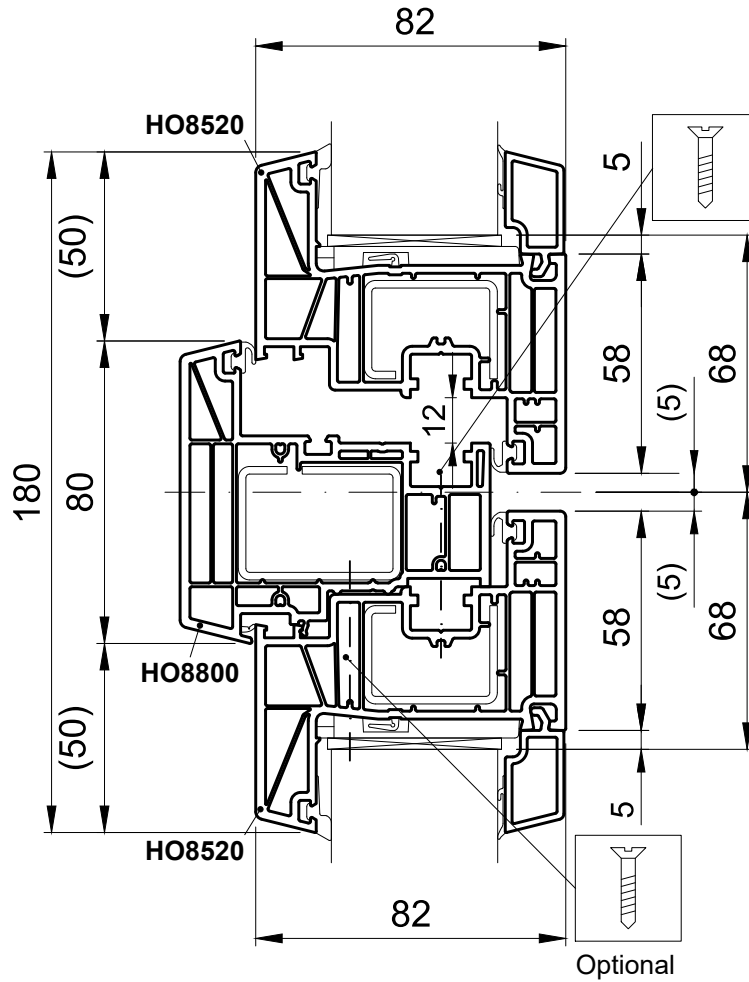

Sash  
**HP8920**

Right-angled profile  
**HO9810**

**Clearance**

Sash width		Faceplate height	
HO9020, HO9021	(RAM/2) – 33 mm	HO9810 Faceplate cap ZS9811	FAM – 84 mm
HO9030	(RAM/2) – 43 mm		
HO9050	(RAM/2) – 63 mm		
HO9100	(RAM/2) – 93 mm		
HO9110	(RAM/2) – 68 mm		
HO9120	(RAM/2) – 57 mm		

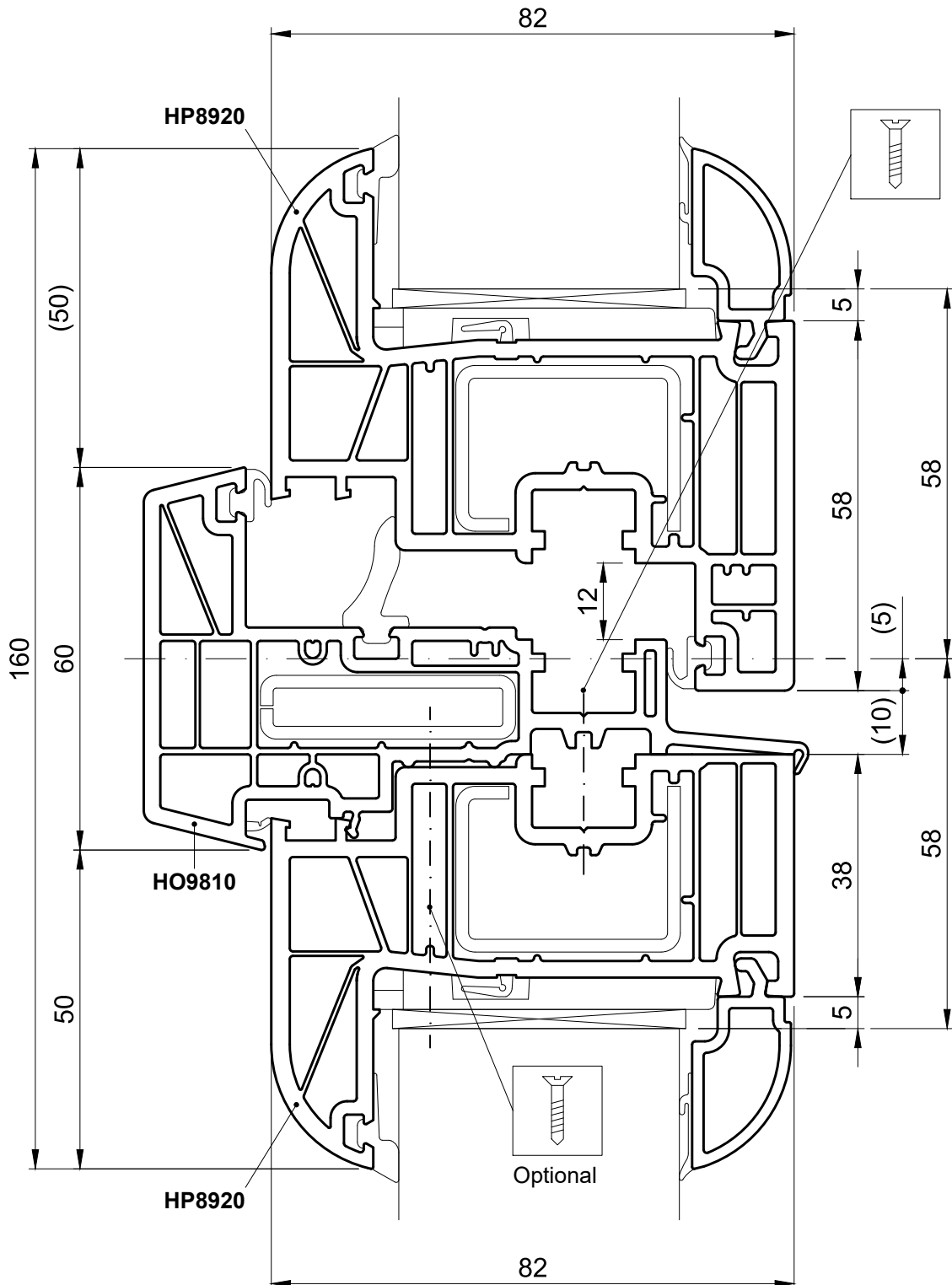

Sash  
HP8920

Right-angled profile  
HO9850

Clearance

Sash width		Faceplate height	
HO9020, HO9021	(RAM/2) – 43 mm	HO9850	FAM – 84 mm
HO9030	(RAM/2) – 53 mm		
HO9050	(RAM/2) – 73 mm	Faceplate cap ZS9851	
HO9100	(RAM/2) – 103 mm		
HO9110	(RAM/2) – 78 mm		
HO9120	(RAM/2) – 67 mm		

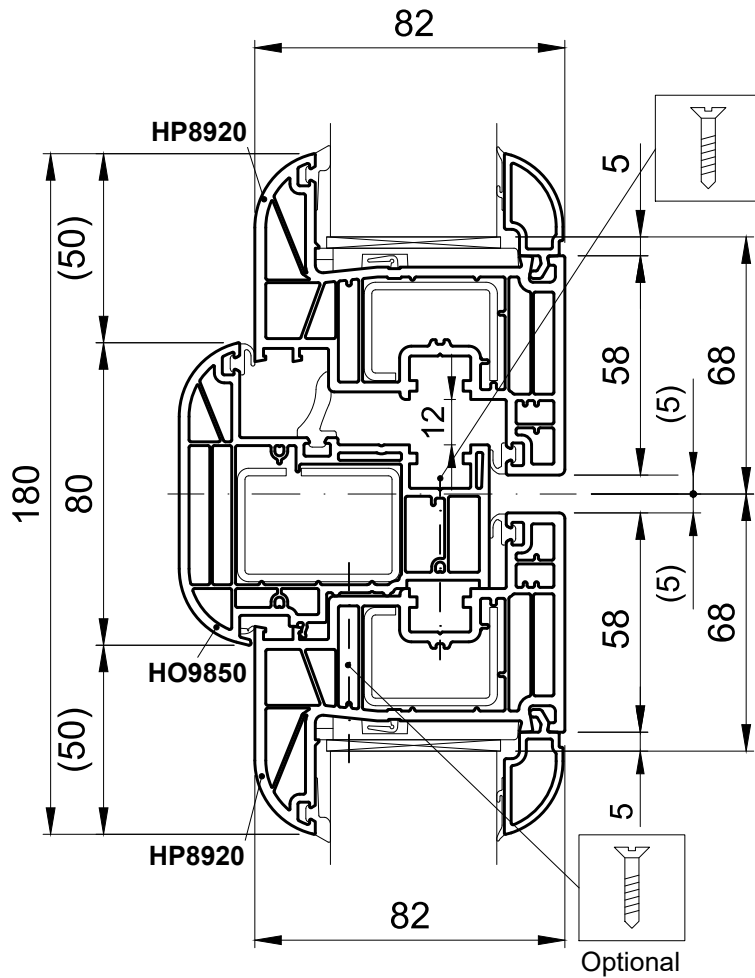

Sash  
**HO8530**

Right-angled profile  
**HO9800**

**Clearance**

Sash width		Faceplate height	
HO9020, HO9021	(RAM/2) – 43 mm	HO9800	FAM – 84 mm
HO9030	(RAM/2) – 53 mm		
HO9050	(RAM/2) – 73 mm	Faceplate cap ZS9801	
HO9100	(RAM/2) – 103 mm		
HO9110	(RAM/2) – 78 mm		
HO9120	(RAM/2) – 67 mm		

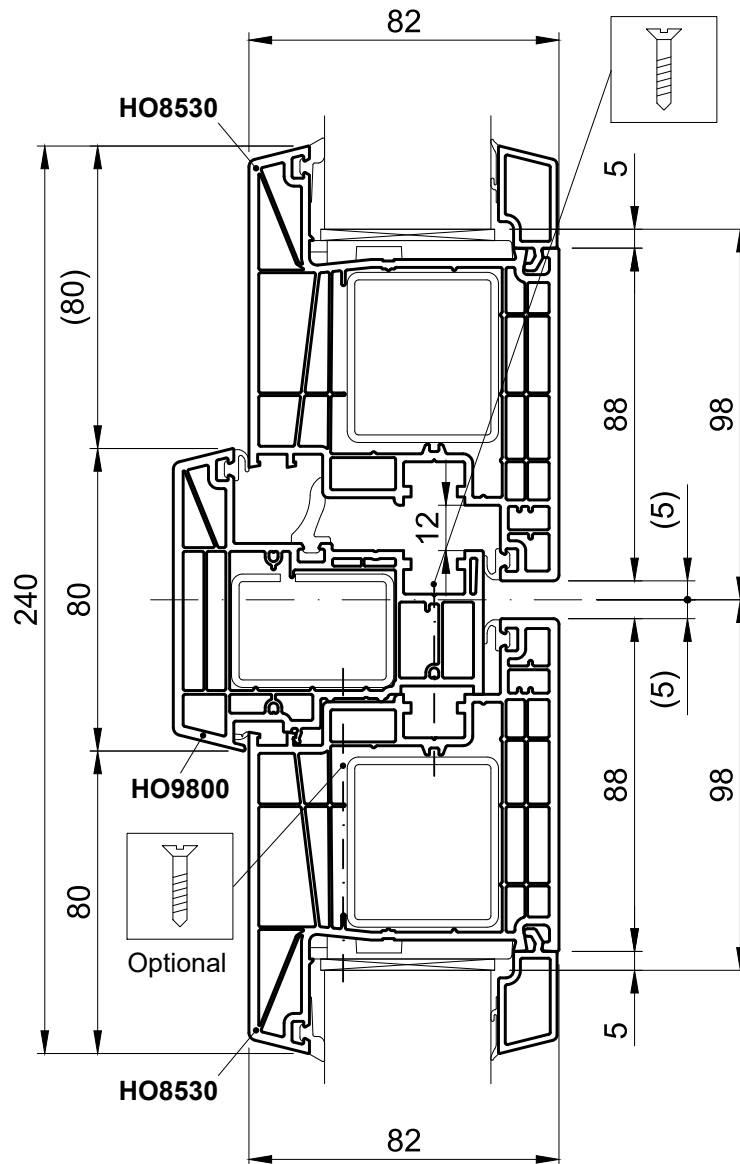

Sash  
HO8530

Right-angled profile  
HO9810

Clearance

Sash width		Faceplate height	
HO9020, HO9021	(RAM/2) – 33 mm	HO9810	FAM – 84 mm
HO9030	(RAM/2) – 43 mm		
HO9050	(RAM/2) – 63 mm	Faceplate cap ZS9811	
HO9100	(RAM/2) – 93 mm		
HO9110	(RAM/2) – 68 mm		
HO9120	(RAM/2) – 57 mm		

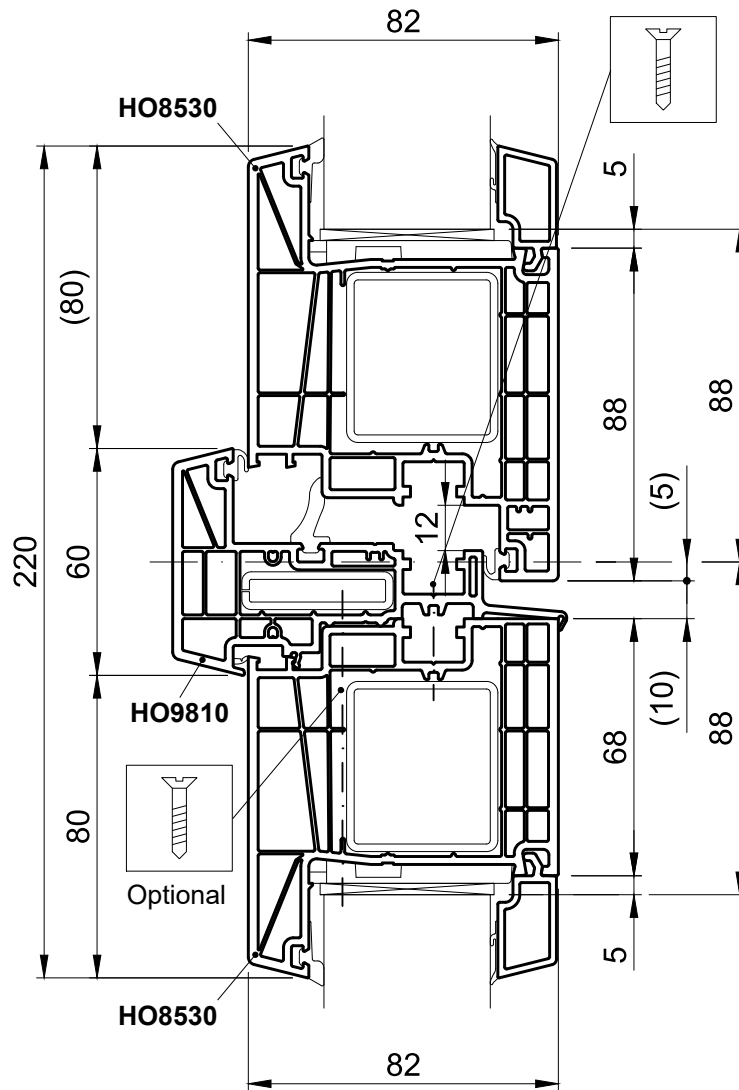

Sash  
**HO8530**

Right-angled profile  
**HO8800**

**Clearance**

Sash width		Faceplate height	
HO8020, HO8021	(RAM/2) – 43 mm	HO8800	FAM – 84 mm
HO8030	(RAM/2) – 53 mm	Faceplate cap ZS8801	

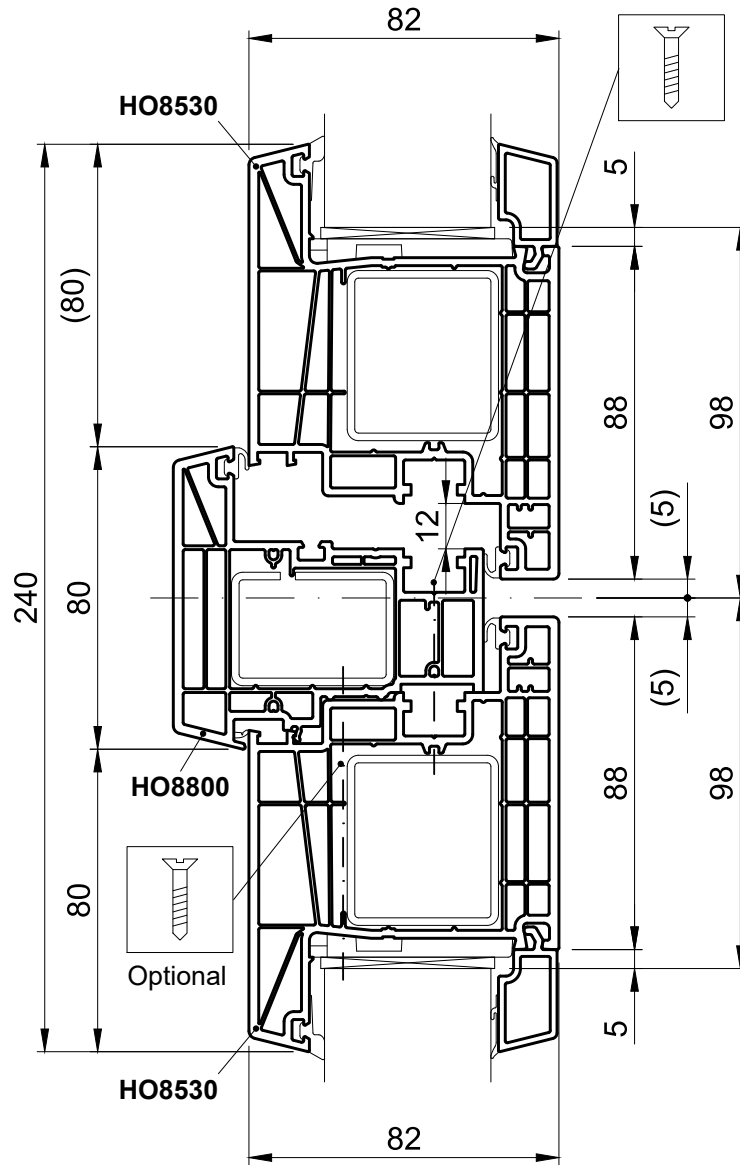

Sash  
HP8930

Right-angled profile  
HO9810

Clearance

Sash width		Faceplate height	
HO9020, HO9021	(RAM/2) – 33 mm	HO9810	FAM – 84 mm
HO9030	(RAM/2) – 43 mm		
HO9050	(RAM/2) – 63 mm	Faceplate cap ZS9811	
HO9100	(RAM/2) – 93 mm		
HO9110	(RAM/2) – 68 mm		
HO9120	(RAM/2) – 57 mm		

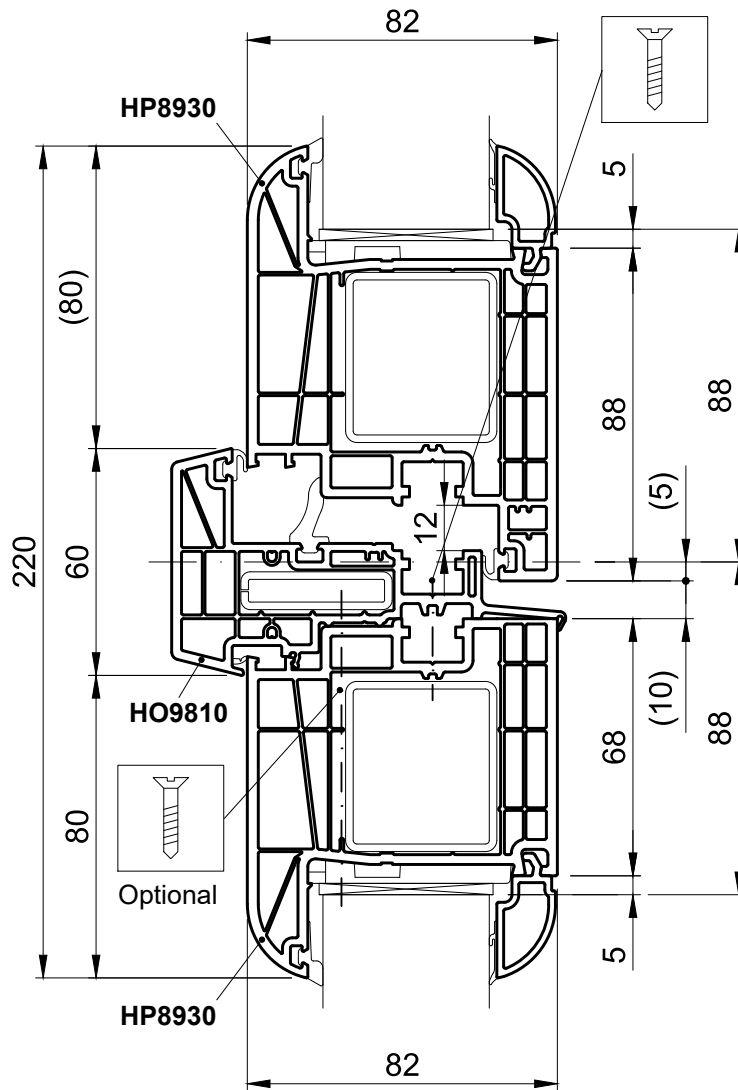

Sash  
**HP8930**

Right-angled profile  
**HO9850**

**Clearance**

Sash width		Faceplate height	
HO9020, HO9021	(RAM/2) – 43 mm	Faceplate cap ZS9851	FAM – 84 mm
HO9030	(RAM/2) – 53 mm		
HO9050	(RAM/2) – 73 mm		
HO9100	(RAM/2) – 103 mm		
HO9110	(RAM/2) – 78 mm		
HO9120	(RAM/2) – 67 mm		

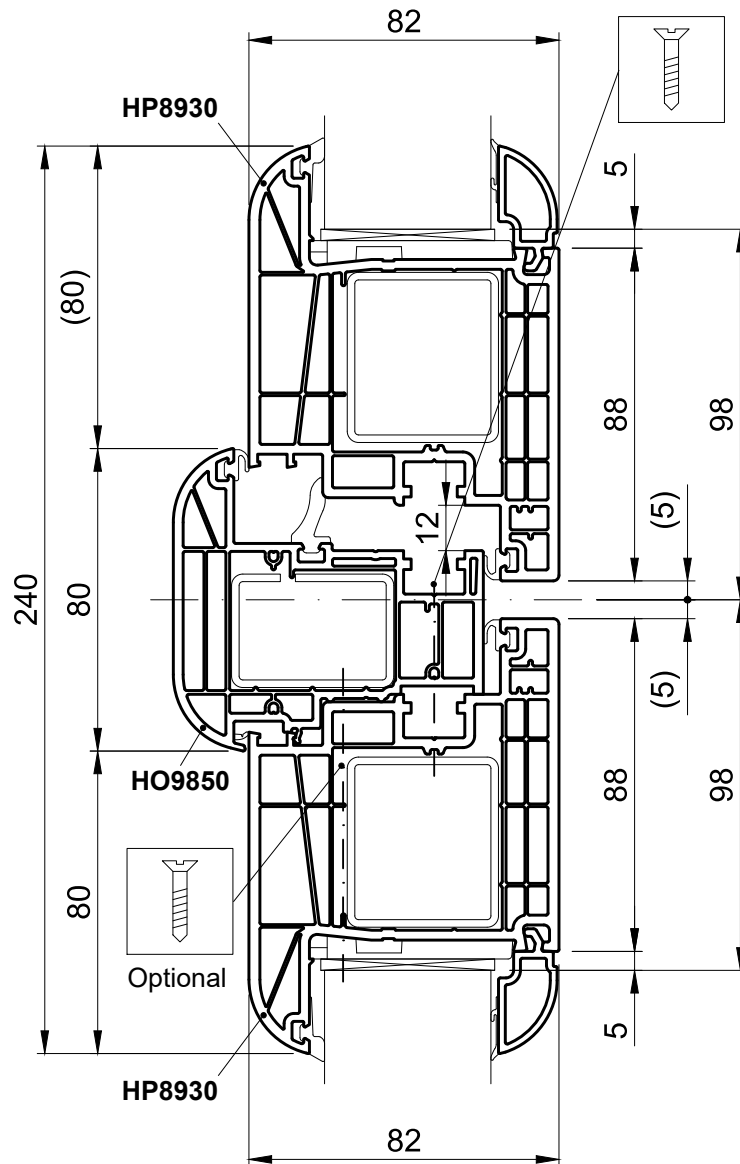

Sash  
HO8540

Right-angled profile  
HO9810

Clearance

Sash width		Faceplate height	
HO9020, HO9021	(RAM/2) – 33 mm	HO9810	FAM – 84 mm
HO9030	(RAM/2) – 43 mm		
HO9050	(RAM/2) – 63 mm	Faceplate cap ZS9811	
HO9100	(RAM/2) – 93 mm		
HO9110	(RAM/2) – 68 mm		
HO9120	(RAM/2) – 57 mm		

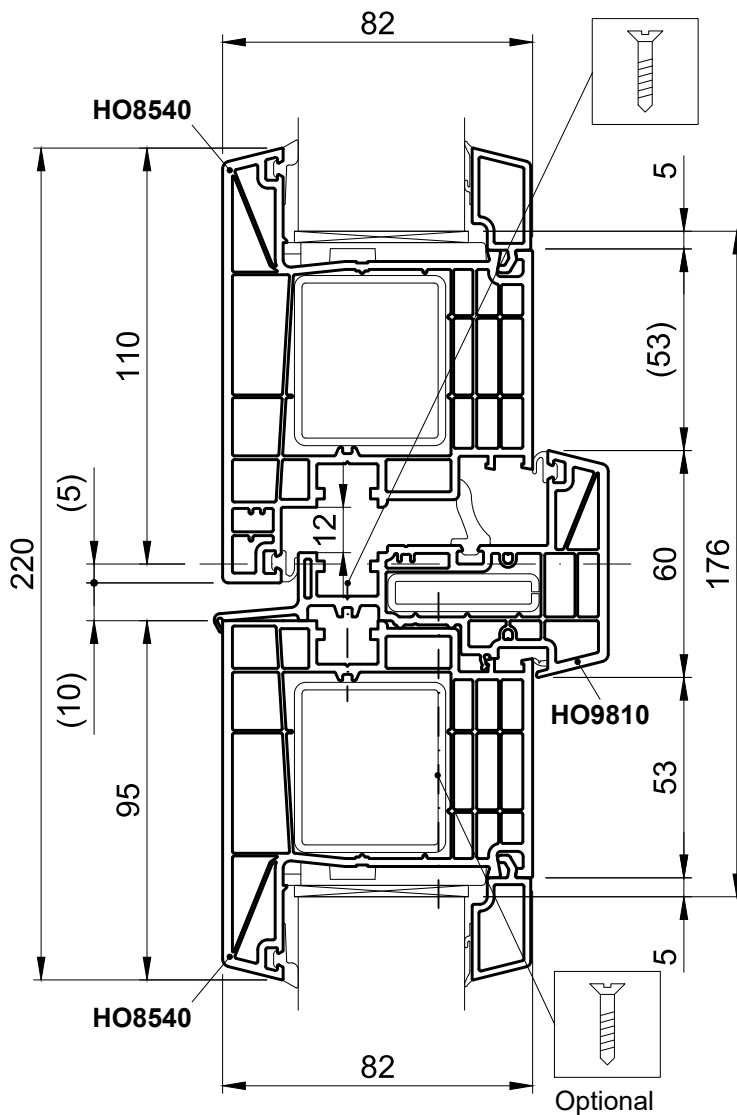

Sash  
**HO8540**

Right-angled profile  
**HO9800**

**Clearance**

Sash width		Faceplate height	
HO9020, HO9021	(RAM/2) – 43 mm	HO9800	FAM – 84 mm
HO9030	(RAM/2) – 53 mm		
HO9050	(RAM/2) – 73 mm	Faceplate cap ZS9801	
HO9100	(RAM/2) – 103 mm		
HO9110	(RAM/2) – 78 mm		
HO9120	(RAM/2) – 67 mm		

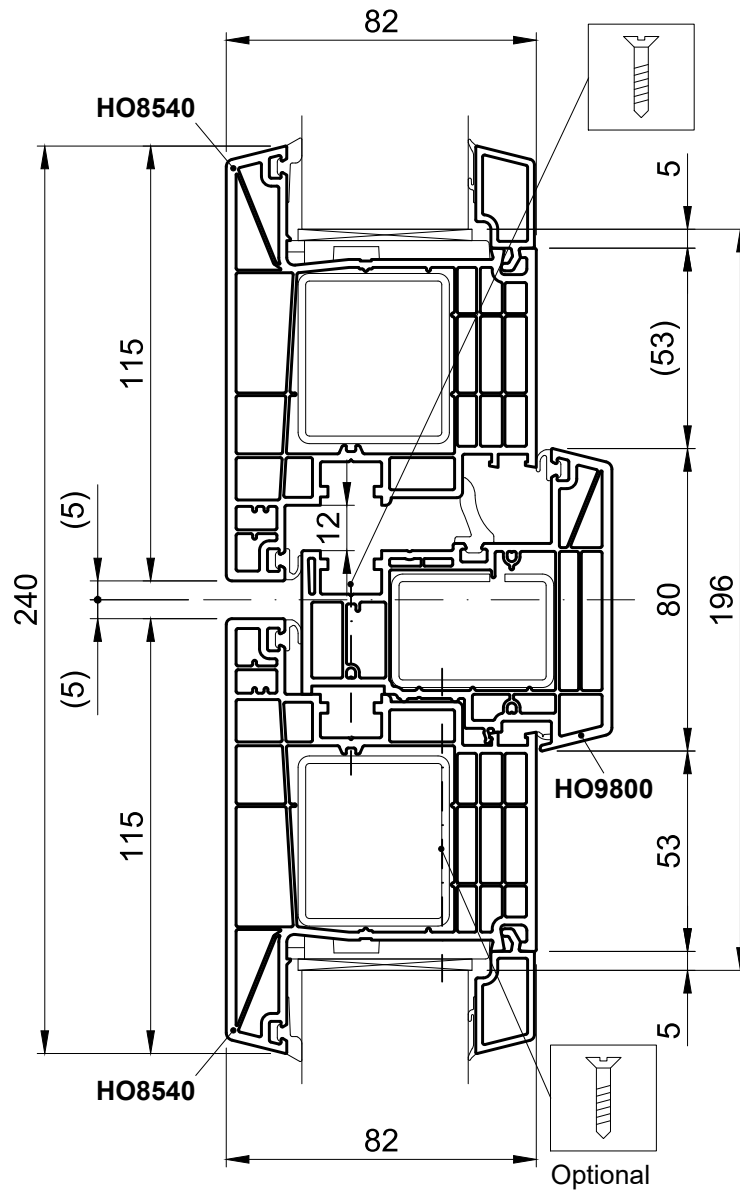

Sash  
HO8540

Right-angled profile  
HO8800

Clearance

Sash width		Faceplate height	
HO8020, HO8021	(RAM/2) – 43 mm	HO8800	FAM – 84 mm
HO8030	(RAM/2) – 53 mm	Faceplate cap ZS8801	

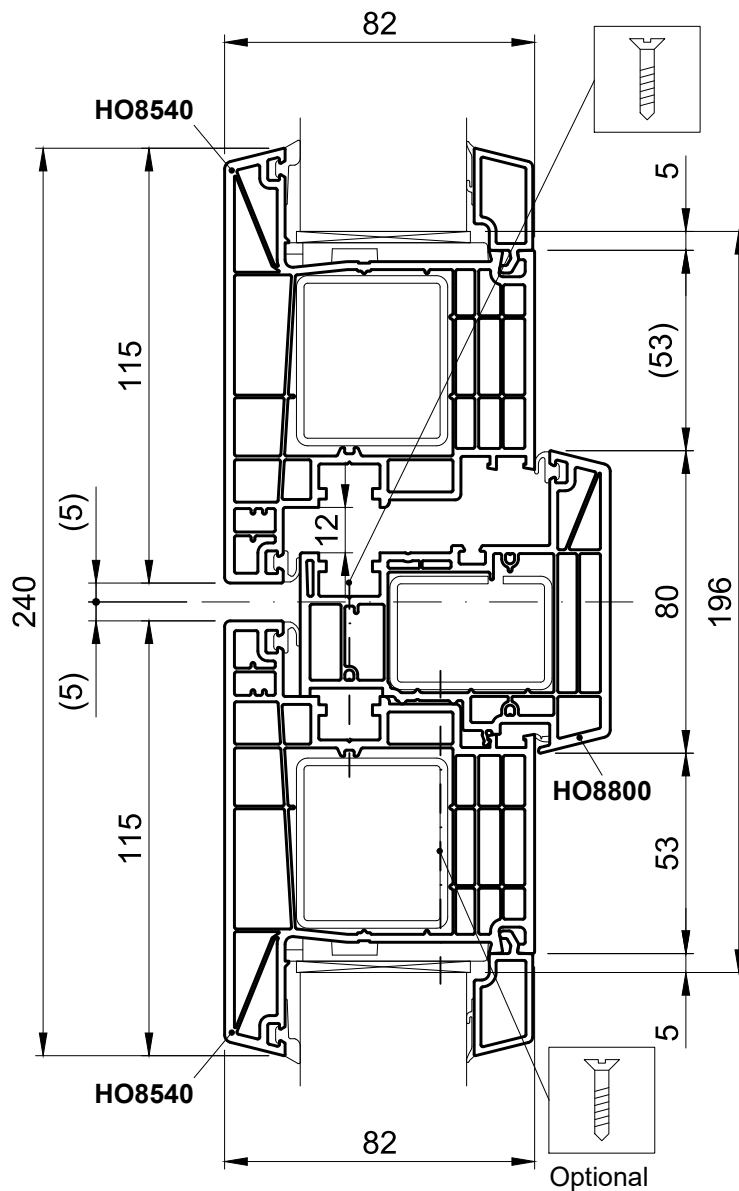

Sash  
**HP8550**

Right-angled profile  
**HO9800**

**Clearance**

Sash width		Faceplate height	
HO9020, HO9021	(RAM/2) – 43 mm	HO9800	FAM – 84 mm
HO9030	(RAM/2) – 53 mm		
HO9050	(RAM/2) – 73 mm	Faceplate cap ZS9801	
HO9100	(RAM/2) – 103 mm		
HO9110	(RAM/2) – 78 mm		
HO9120	(RAM/2) – 67 mm		

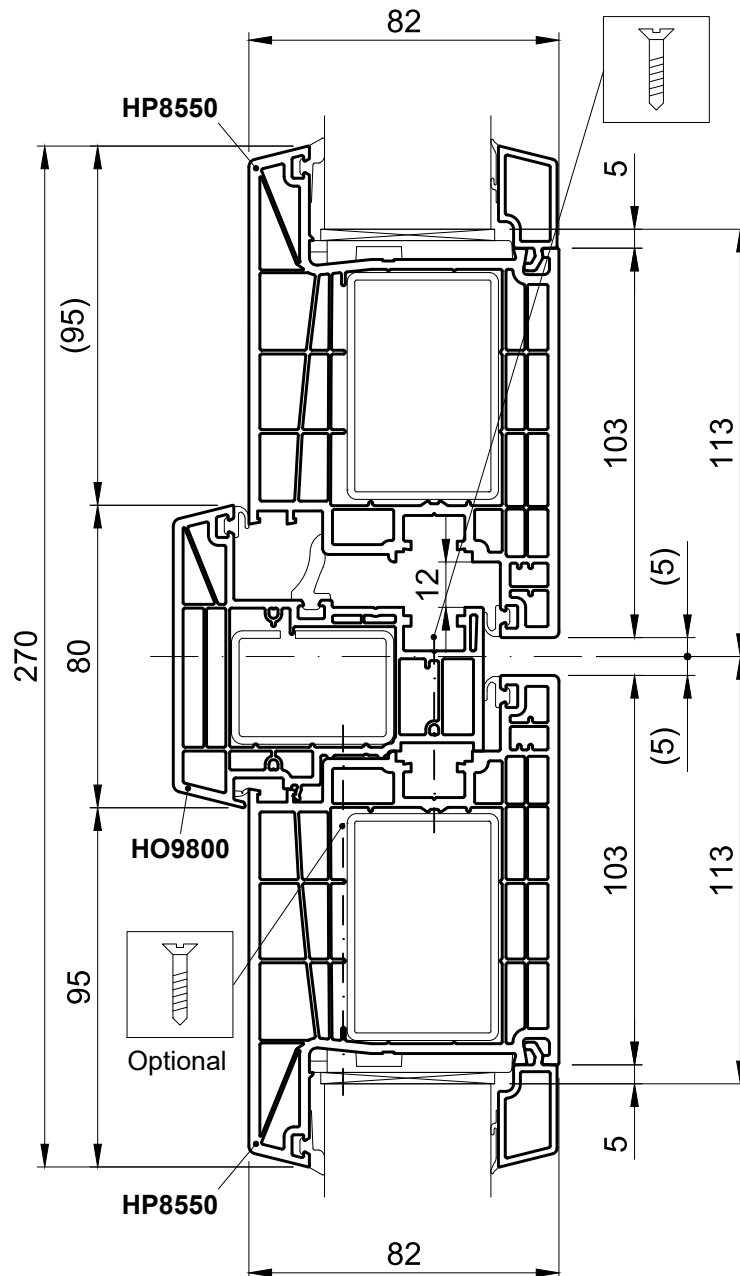

Sash  
HP8550

Right-angled profile  
HO8800

Clearance

Sash width		Faceplate height	
HO8020, HO8021	(RAM/2) – 43 mm	HO8800	FAM – 84 mm
HO8030	(RAM/2) – 53 mm		
		Faceplate cap ZS8801	

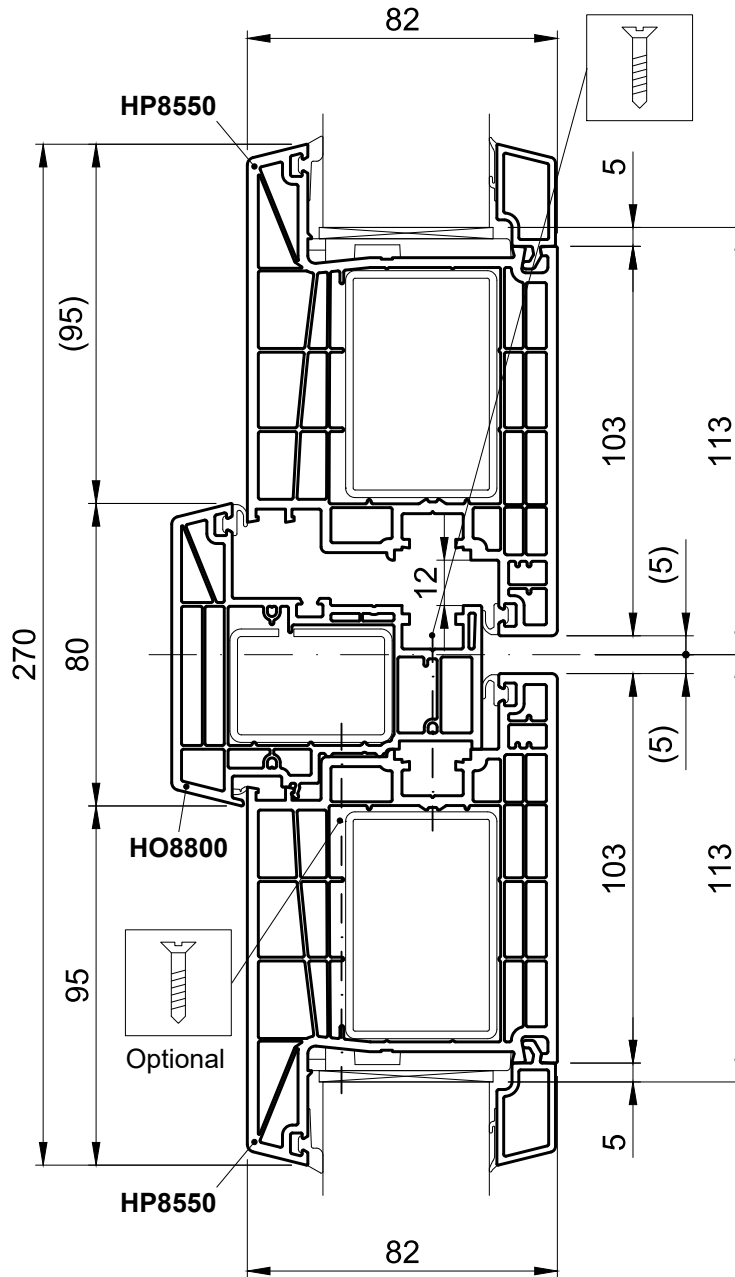

Sash  
**HP8560**

Right-angled profile  
**HO9800**

**Clearance**

Sash width		Faceplate height	
HO9020, HO9021	(RAM/2) – 43 mm	HO9800	FAM – 84 mm
HO9030	(RAM/2) – 53 mm		
HO9050	(RAM/2) – 73 mm	Faceplate cap ZS9801	
HO9100	(RAM/2) – 103 mm		
HO9110	(RAM/2) – 78 mm		
HO9120	(RAM/2) – 67 mm		

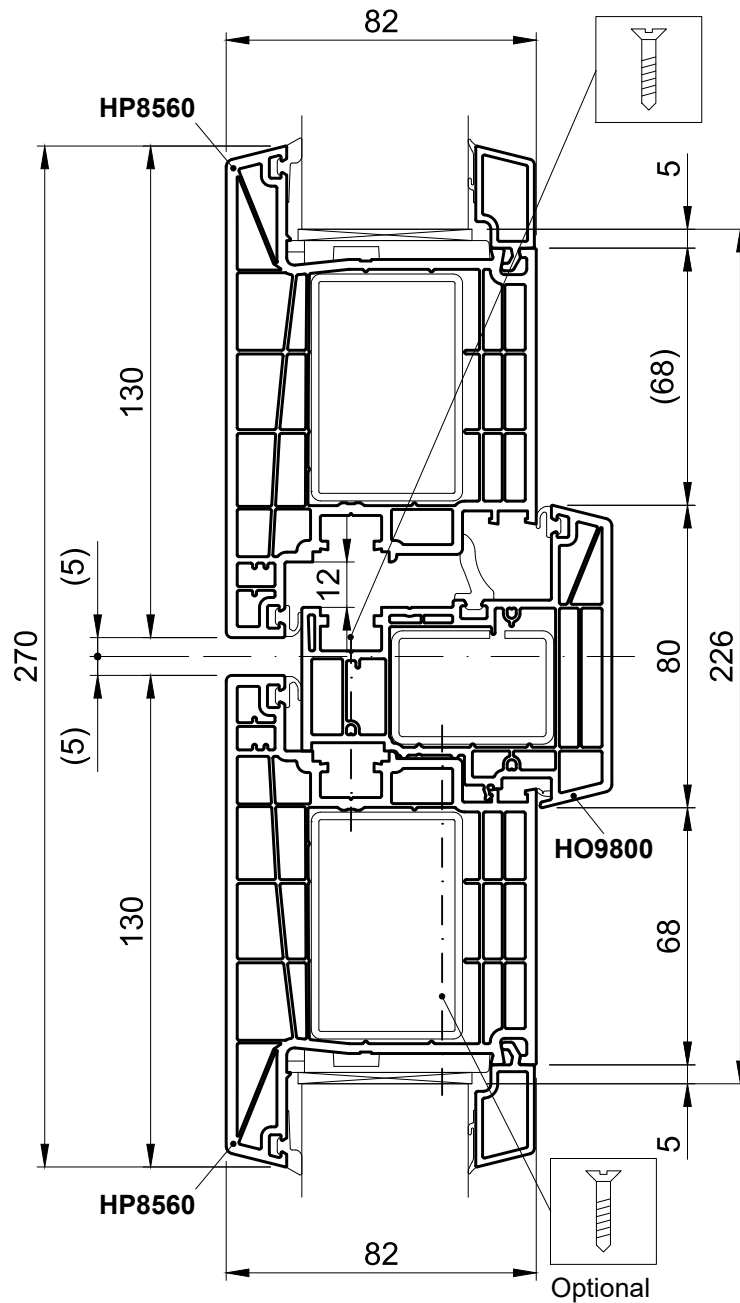

Sash  
HP8560

Right-angled profile  
HO8800

Clearance

Sash width		Faceplate height	
HO8020, HO8021	(RAM/2) – 43 mm	HO8800	FAM – 84 mm
HO8030	(RAM/2) – 53 mm	Faceplate cap ZS8801	

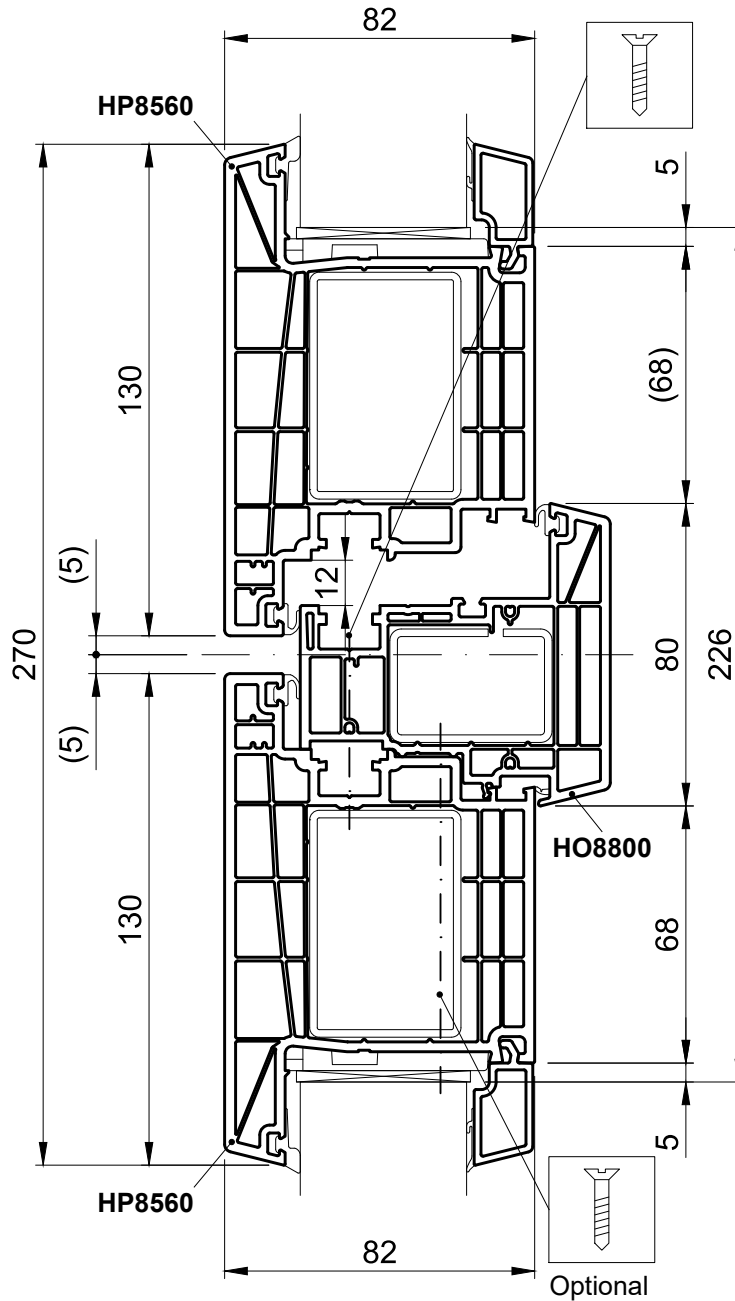

Door threshold  
**ZS7110**

Sash  
**HO8520**

Weather profile strip  
**VA7215**

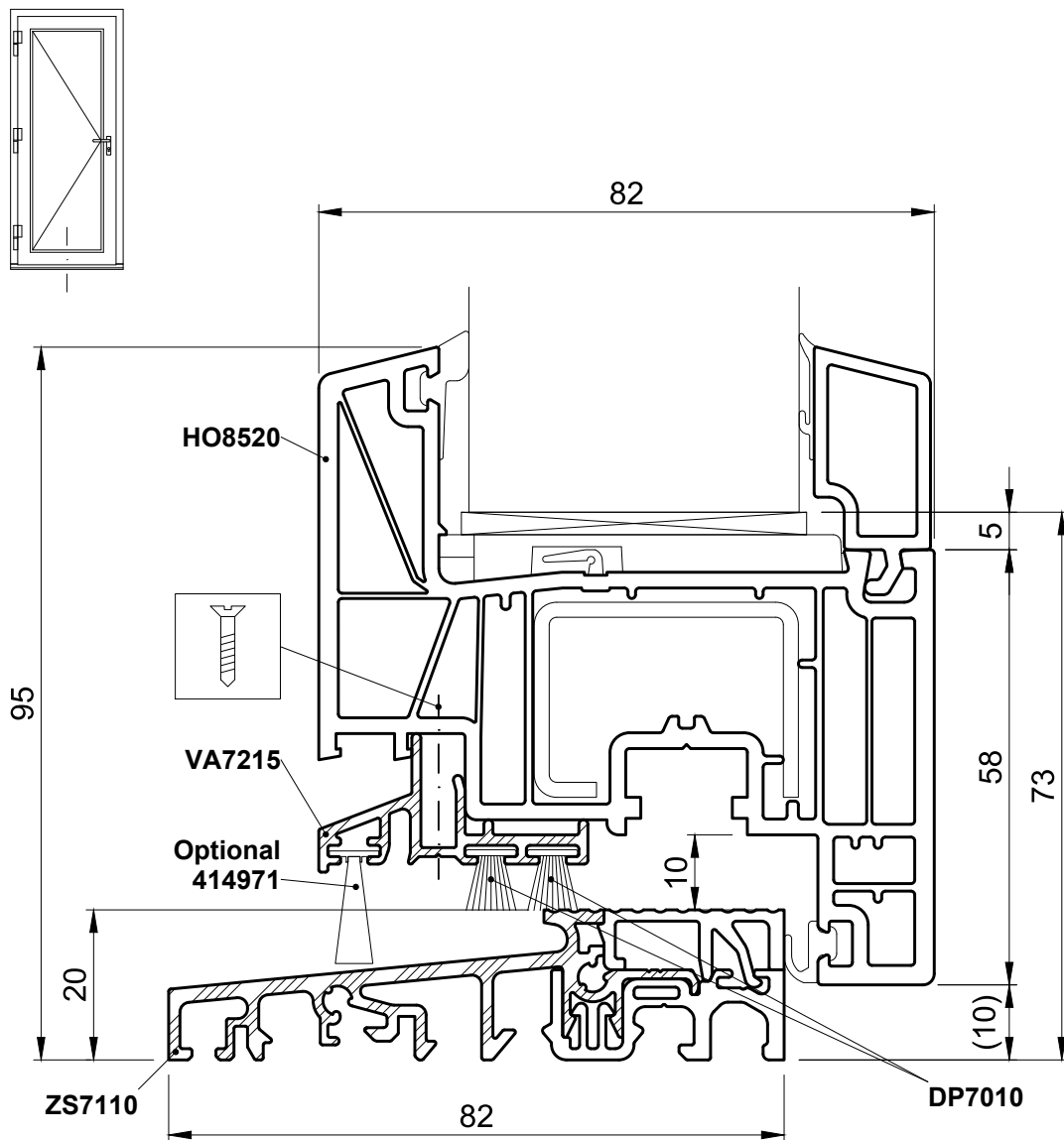

Door threshold  
ZS7110

Sash  
HP8920

Weather profile strip  
VA7215

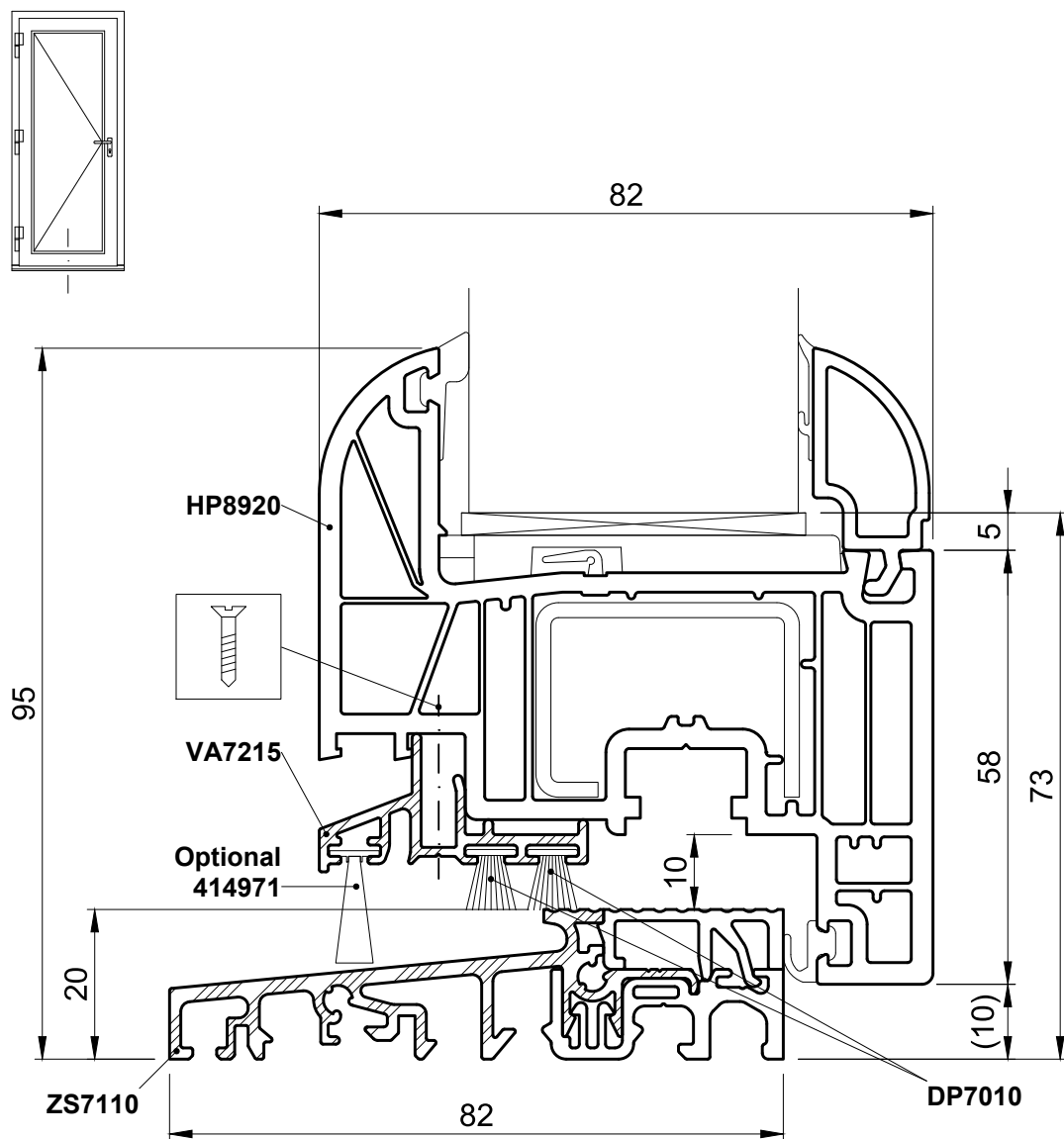

Door threshold  
**ZS7110**

Sash  
**HO8530**

Weather profile strip  
**VA7215**

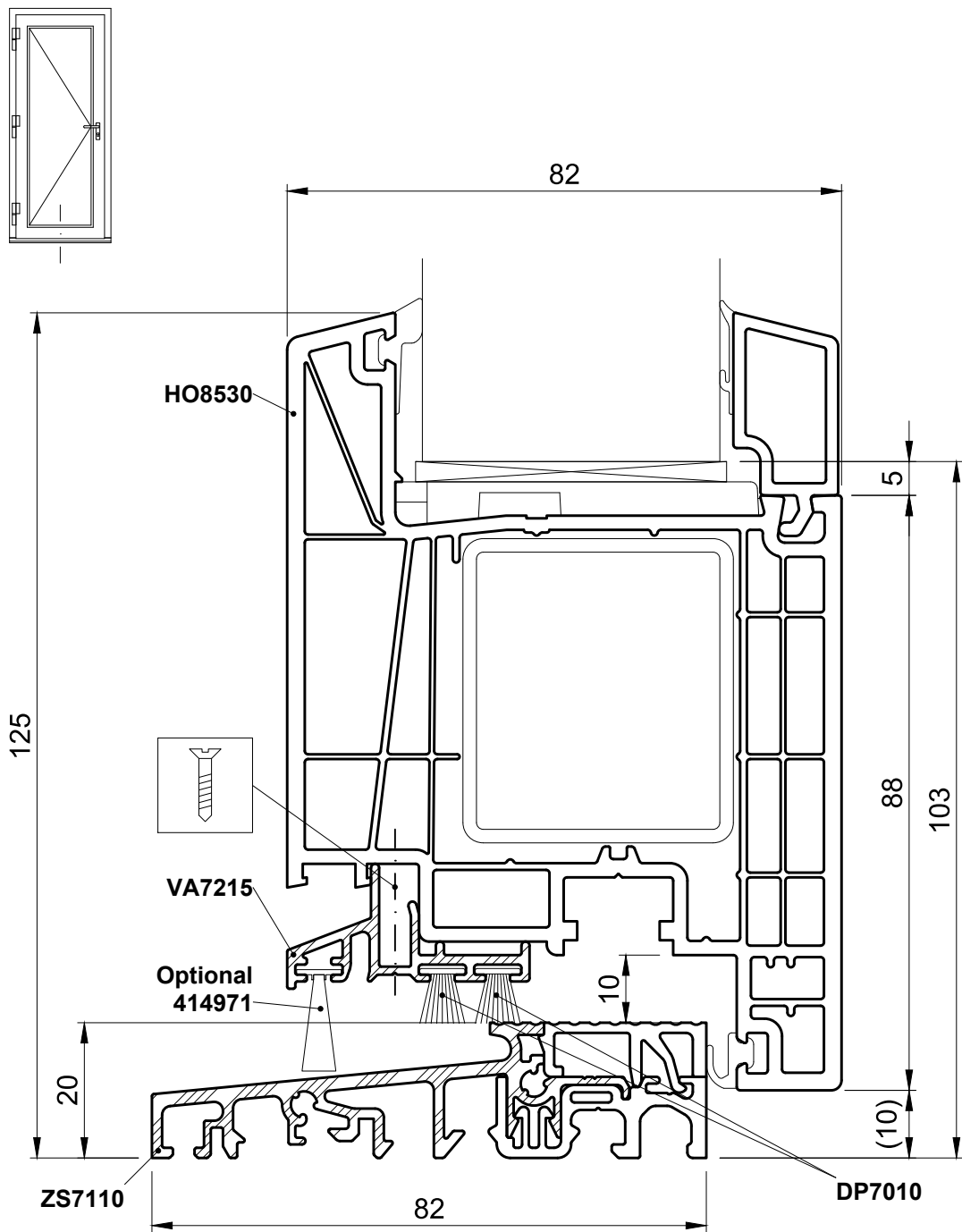

Door threshold  
ZS7110

Sash  
HP8930

Weather profile strip  
VA7215

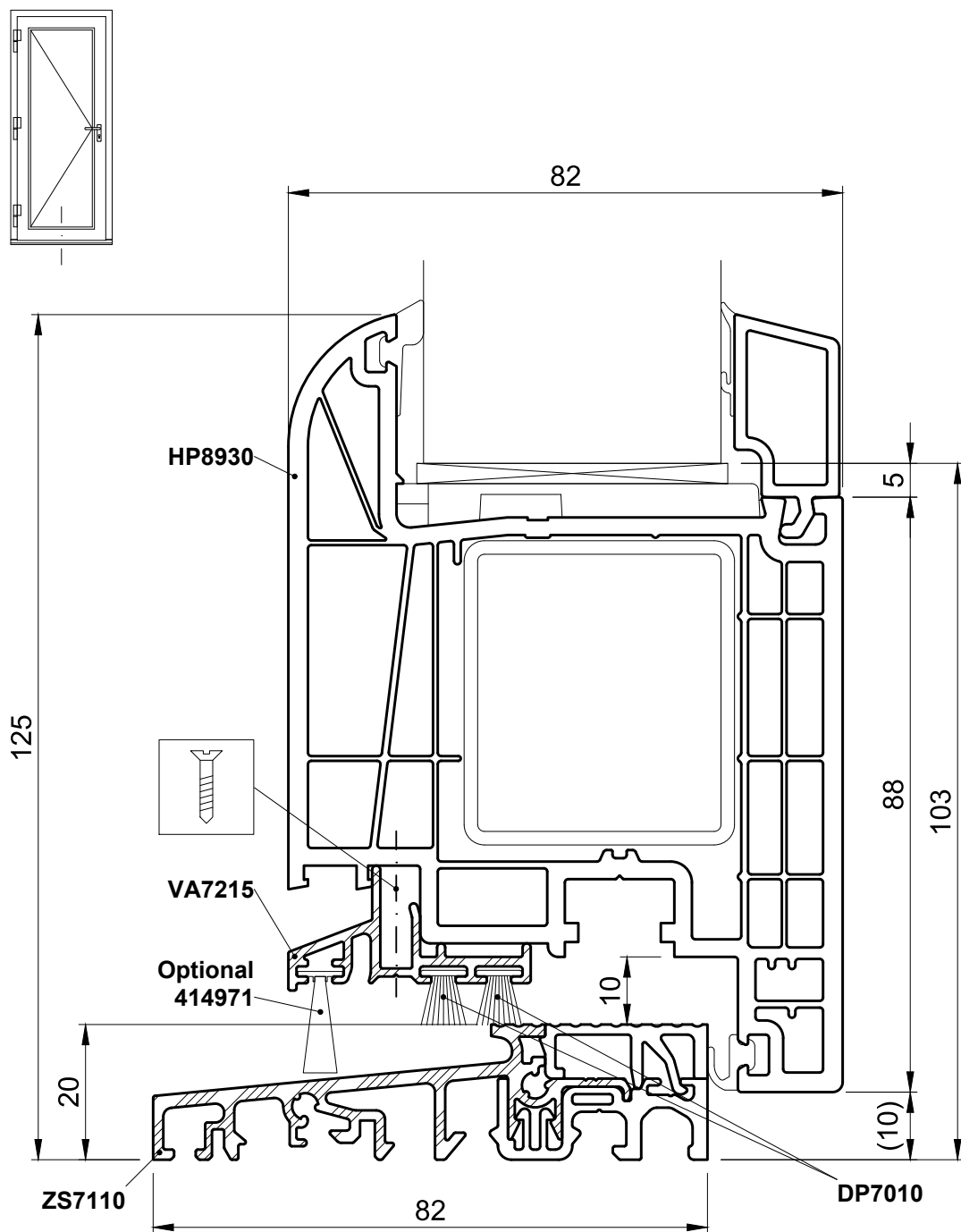

Door threshold  
**ZS7110**

Sash  
**HP8550**

Weather profile strip  
**VA7215**

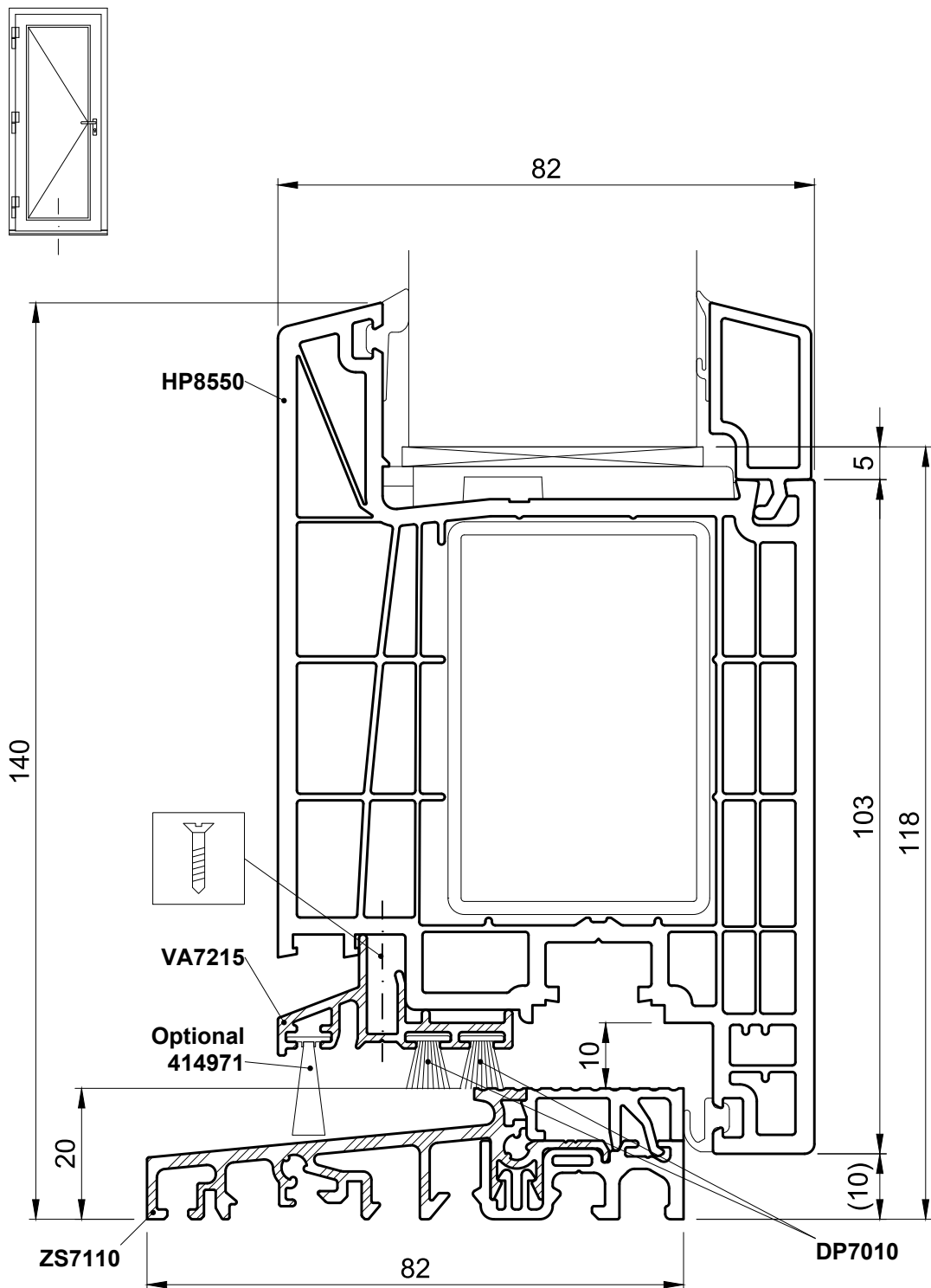

Door threshold  
ZS7110

Sash  
HO8580

Weather profile strip  
VA7215

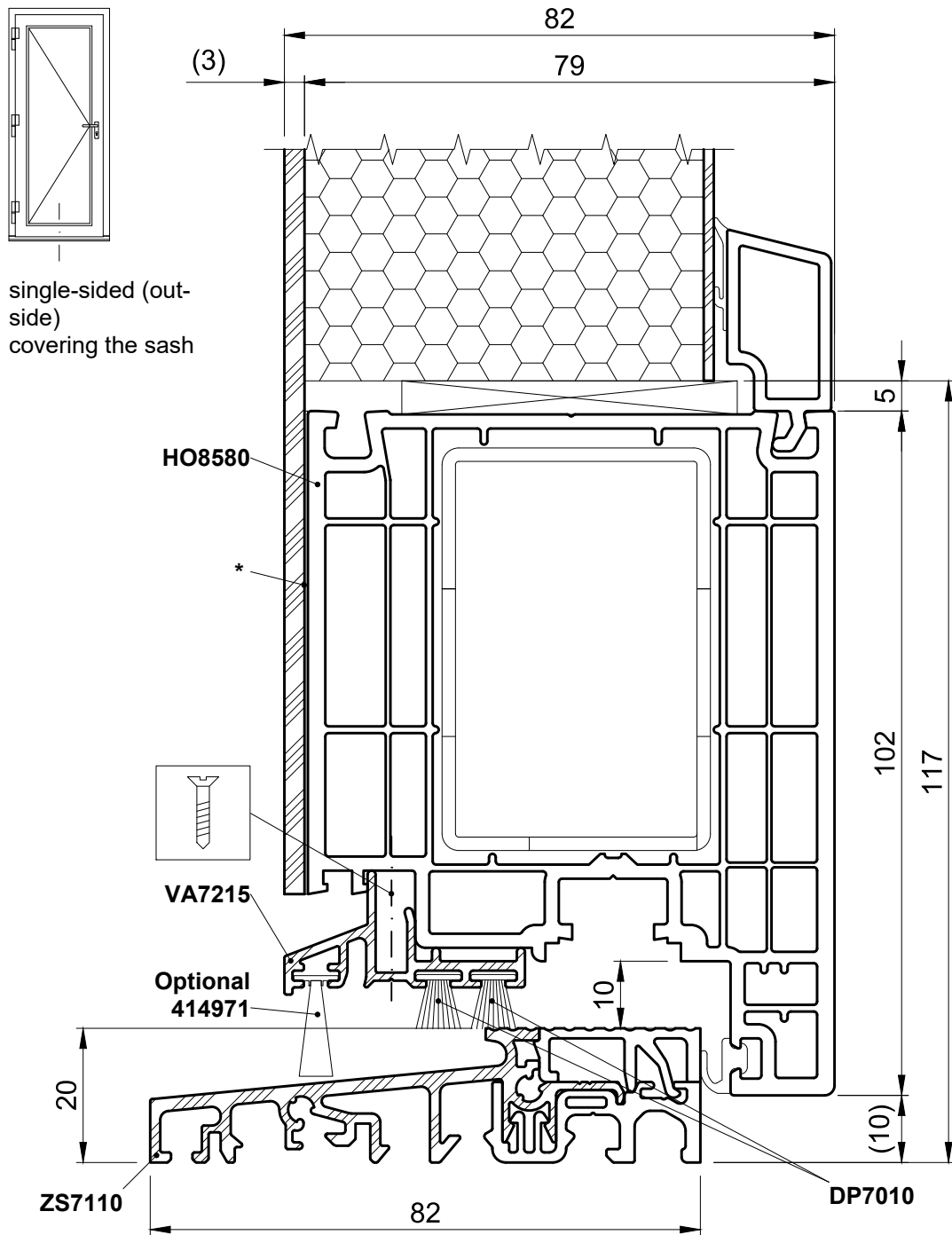

**i** INFO

\*The bond between the aluminium filling and the PVC profile must be carried out in accordance with the guidelines and directives of the filling supplier!

Door threshold  
**ZS7110**

Sash  
**HO8580**

Weather profile strip  
**VA7215**

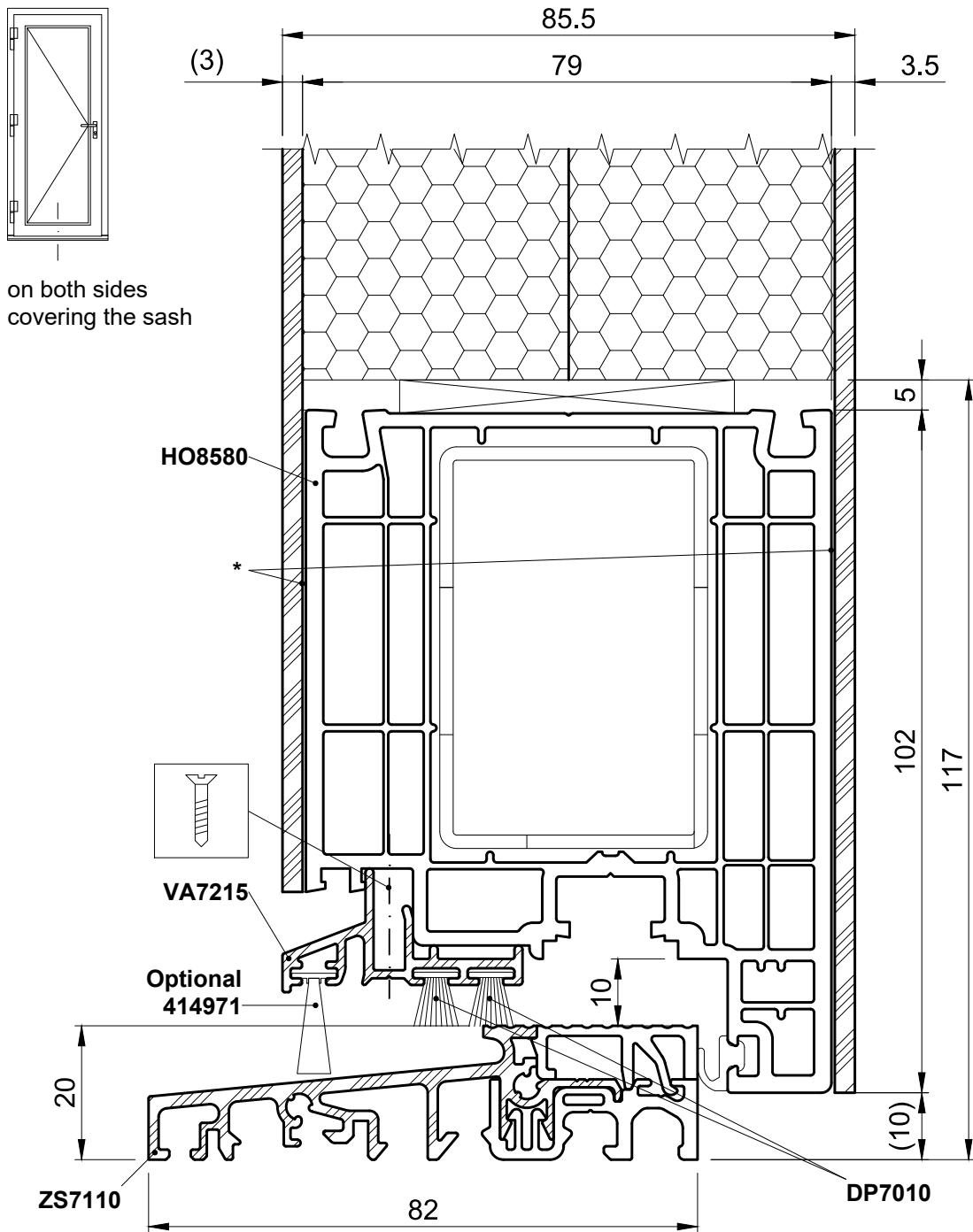

**i** INFO

\*The bond between the aluminium filling and the PVC profile must be carried out in accordance with the guidelines and directives of the filling supplier!

Door threshold  
ZS7110

Attachment profile  
VA7125

Sash  
HO8540

Weather profile strip  
VA7215

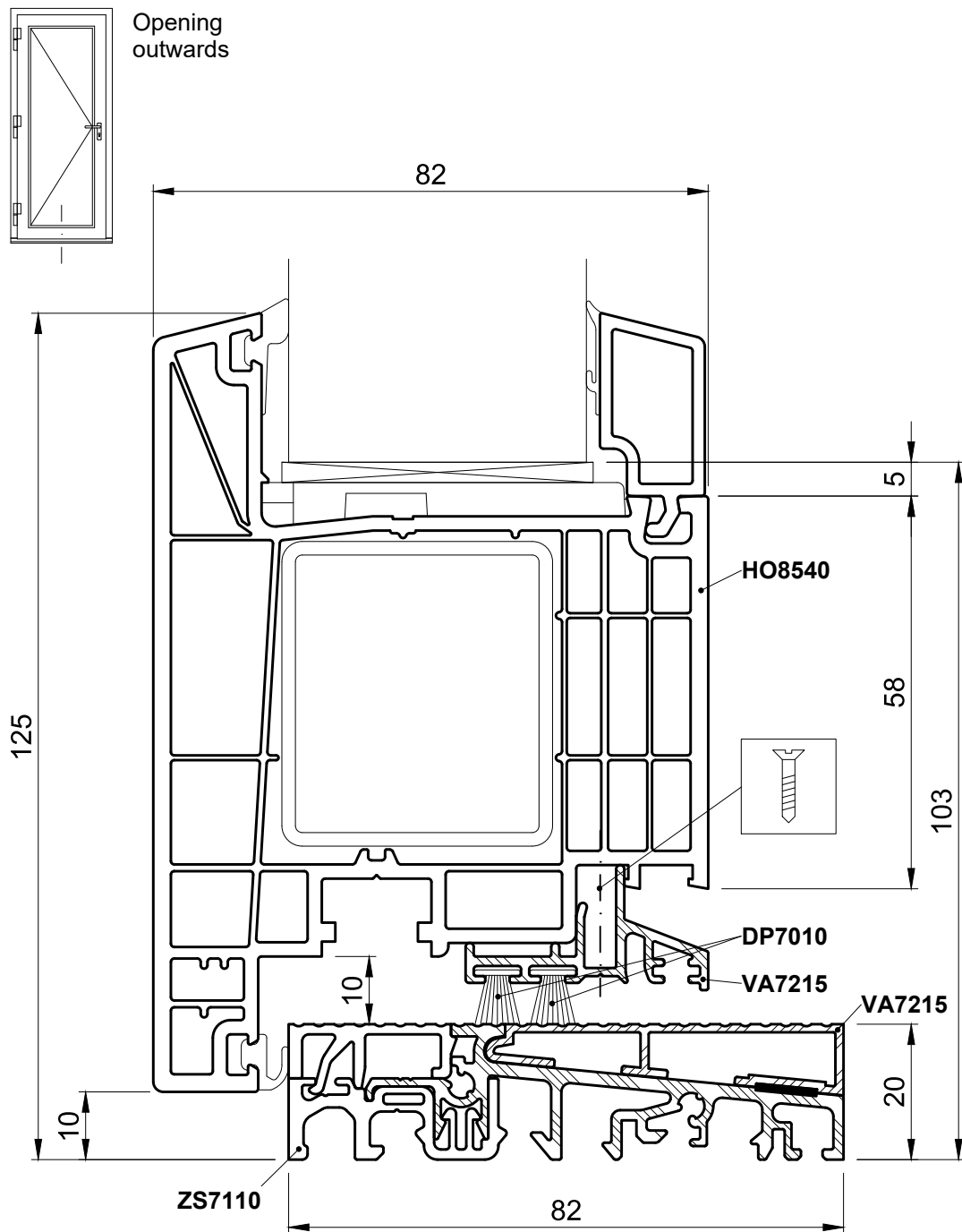

Door threshold  
**ZS7110**

Attachment profile  
**VA7125**

Sash  
**HP8560**

Weather profile strip  
**VA7215**

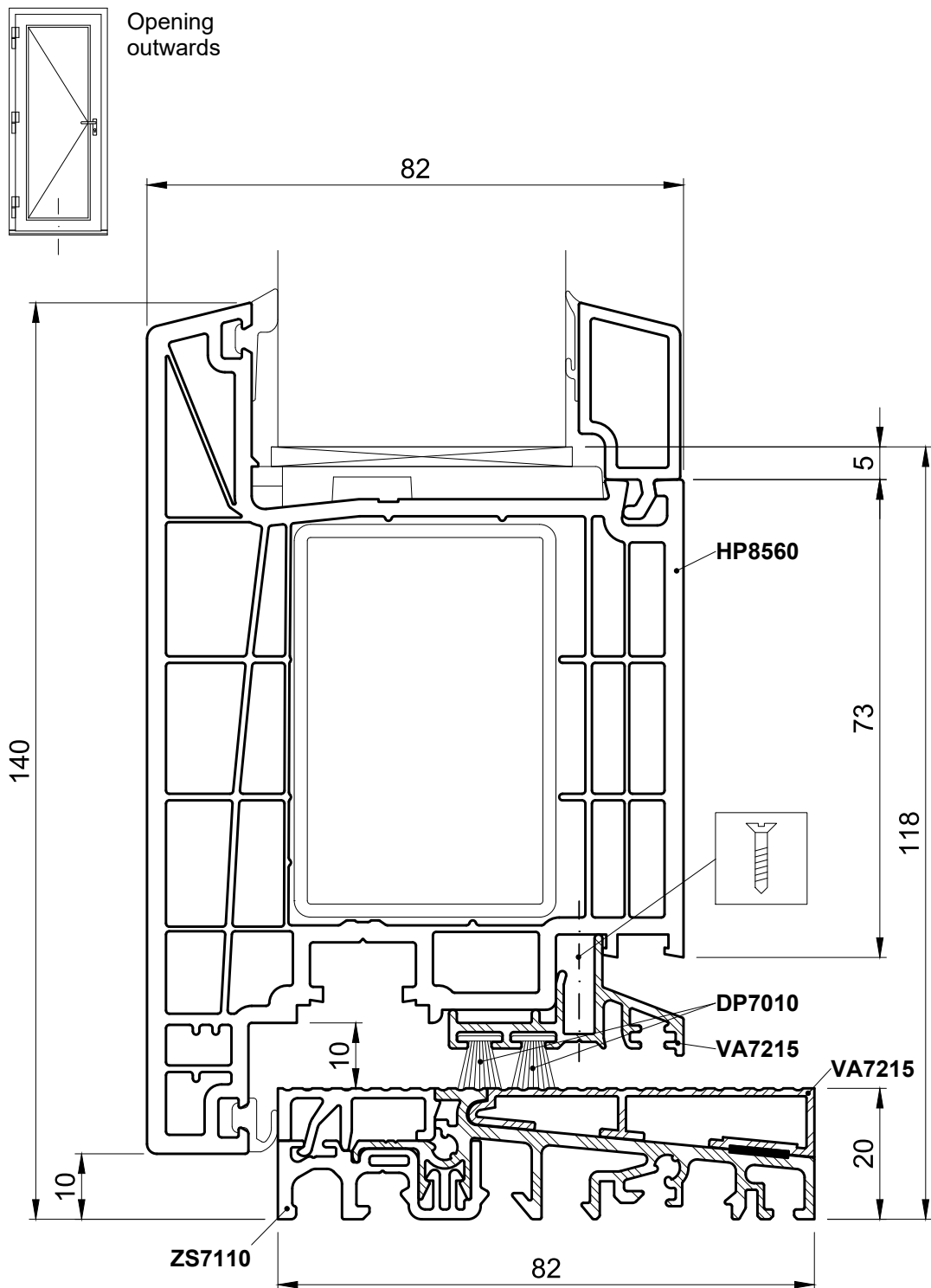

Door threshold  
ZS7120

Sash  
XXXXXX

Weather profile strip  
VA7215

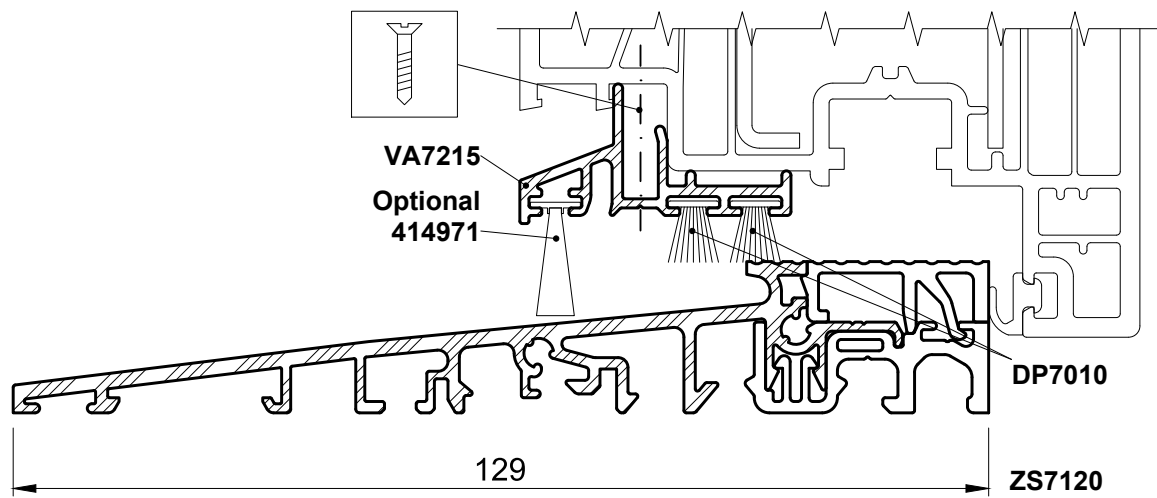

Door threshold  
**ZS7125**

Sash  
**HO8540**

Weather profile strip  
**VA7215**

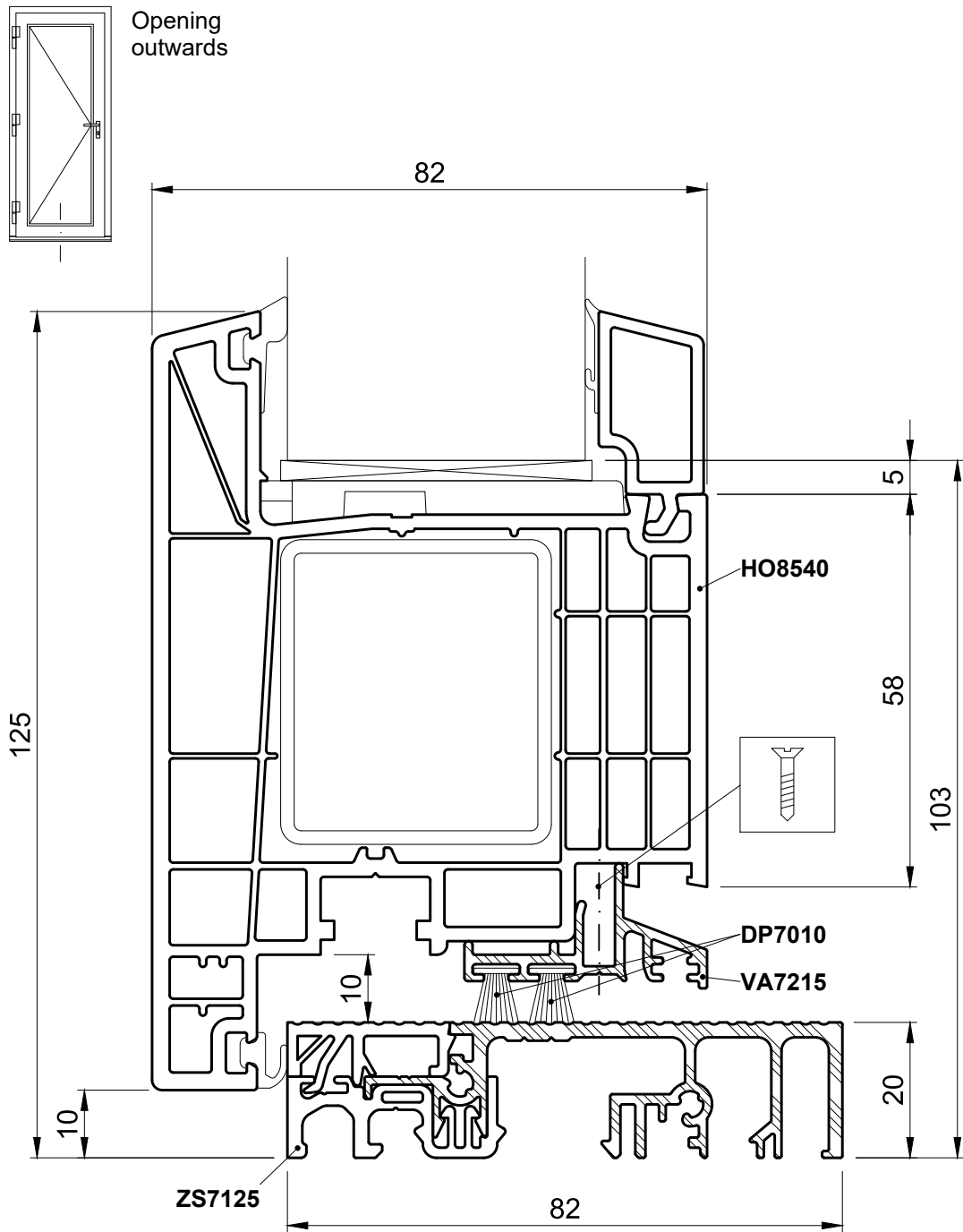

Door threshold  
ZS7125

Sash  
HP8560

Weather profile strip  
VA7215

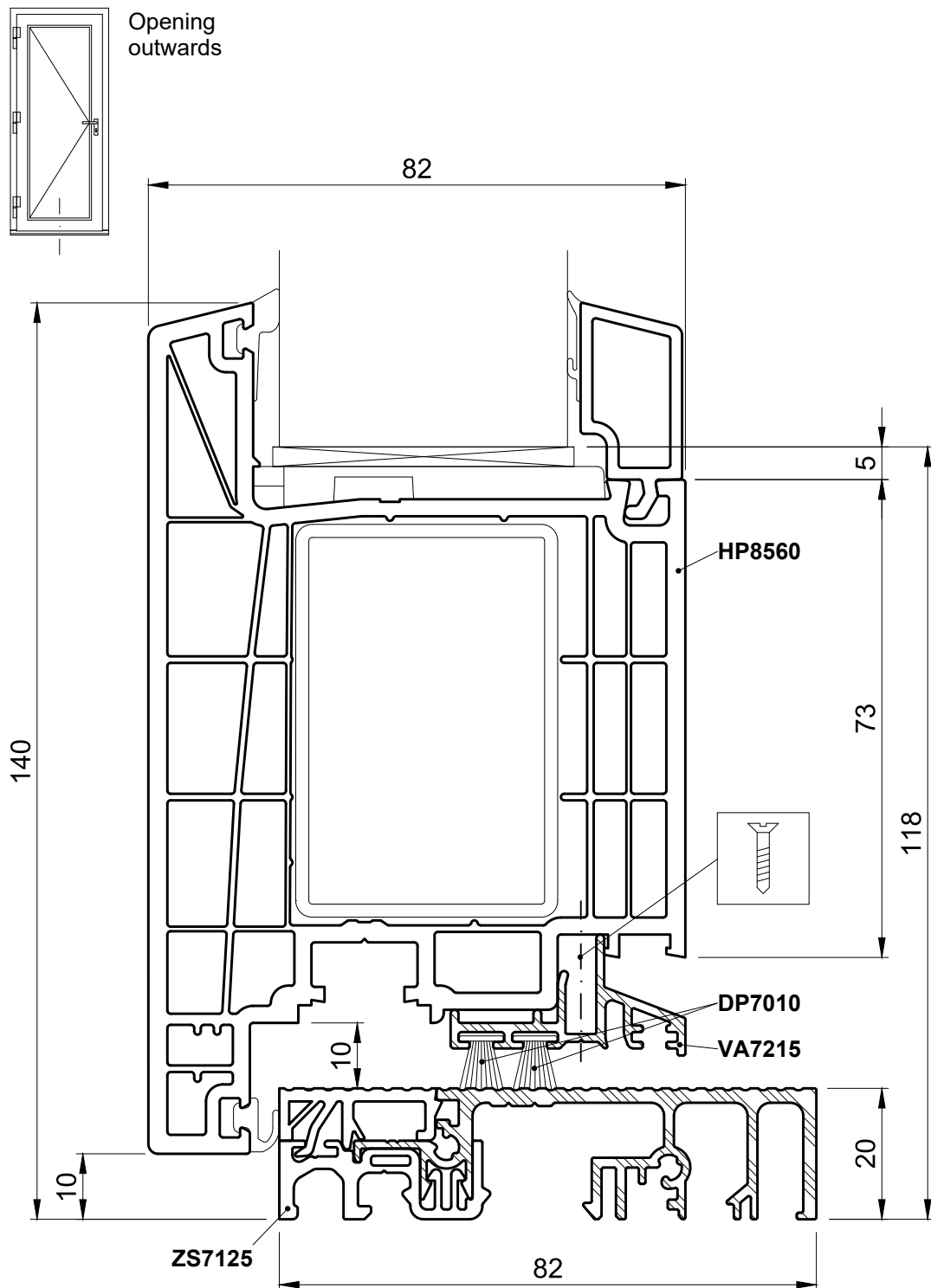

Door threshold  
**ZS7110**

Sash  
**HO8520**

Compensating piece  
**VA7410**

Weather profile strip  
**ZF1940**

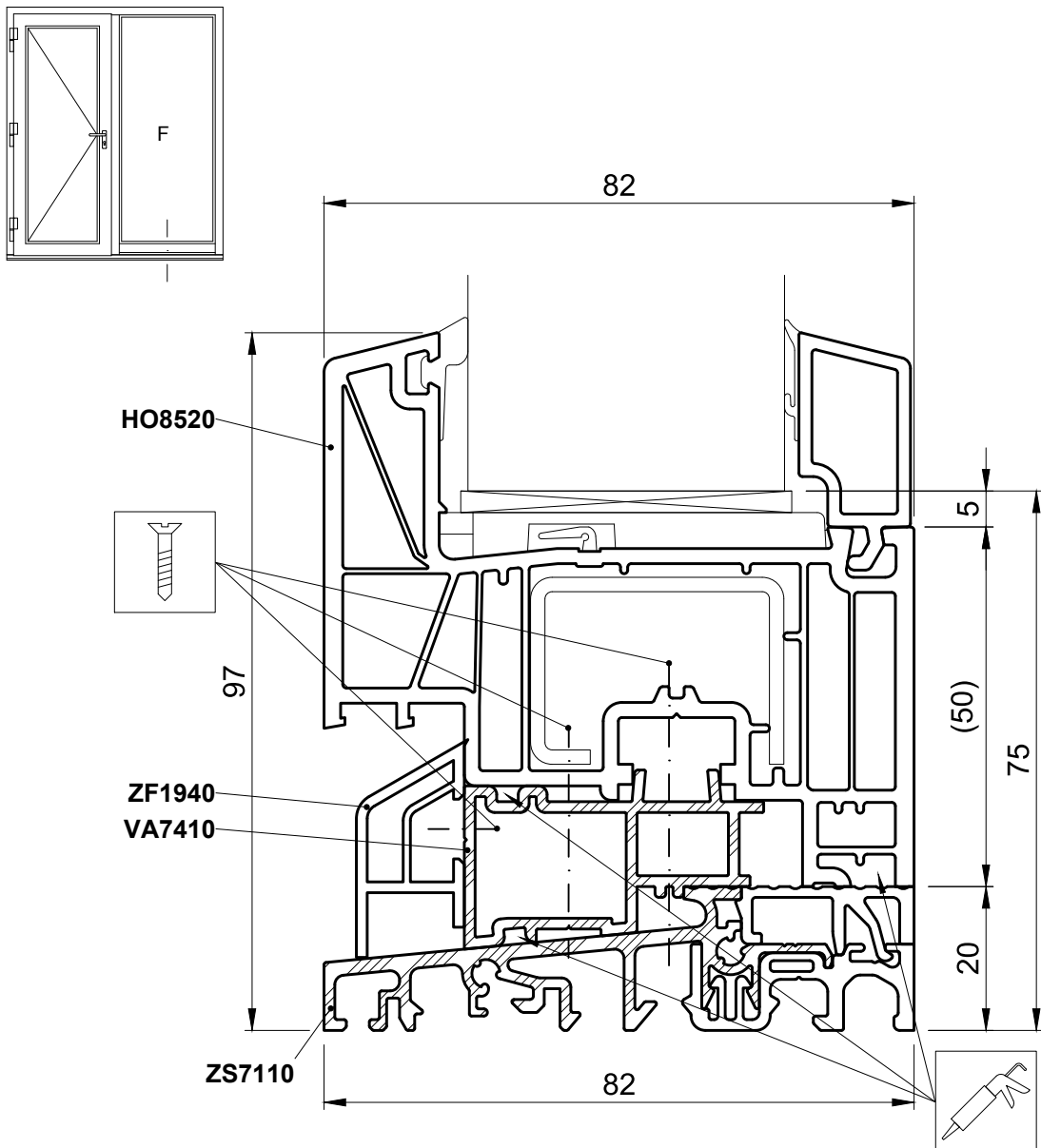

Door threshold  
ZS7110

Sash  
HP8920

Compensating piece  
VA7410

Weather profile strip  
ZF1940

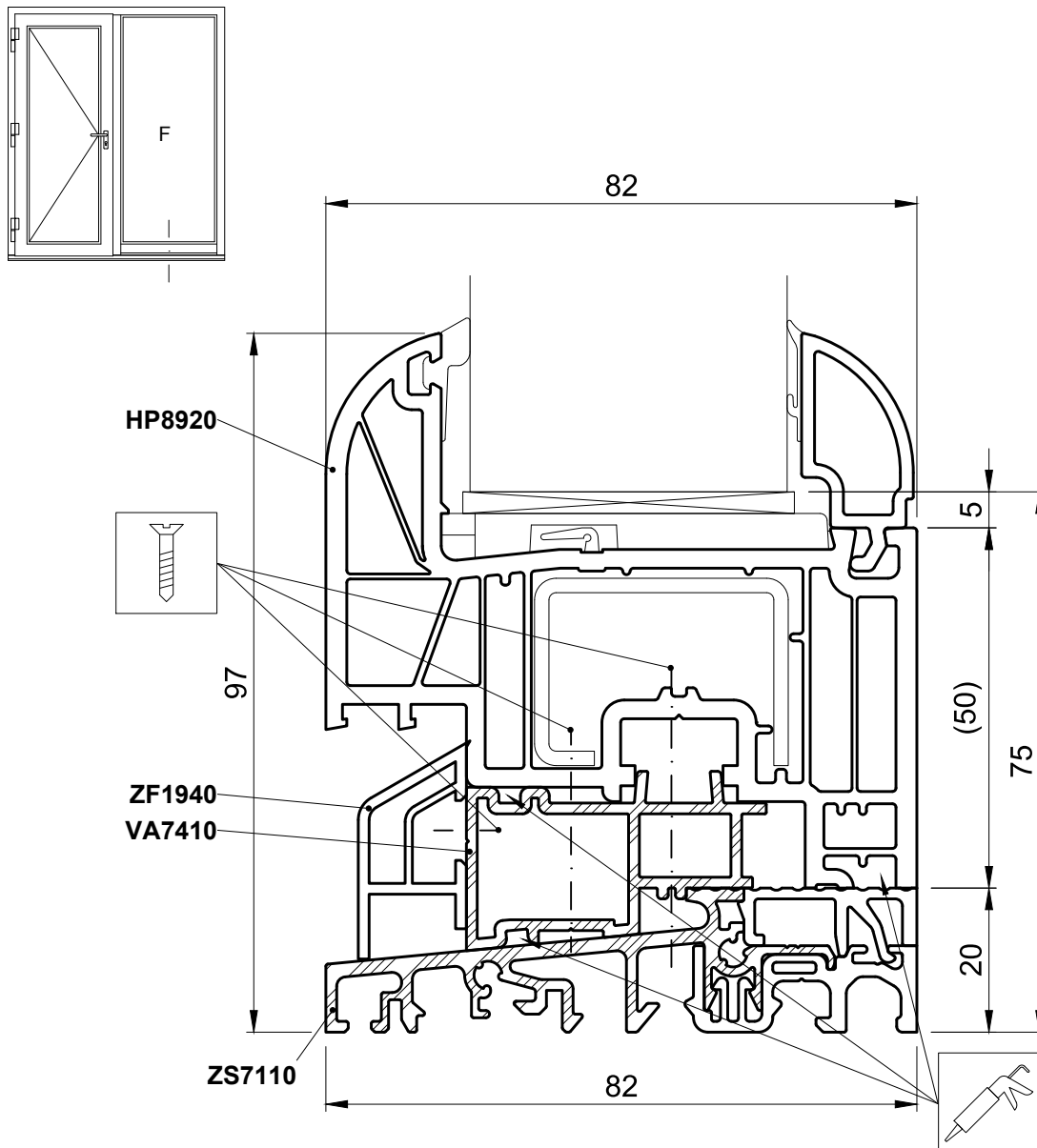



Door threshold  
ZS7110

Sash  
HP8930

Compensating piece  
VA7410

Weather profile strip  
ZF1940

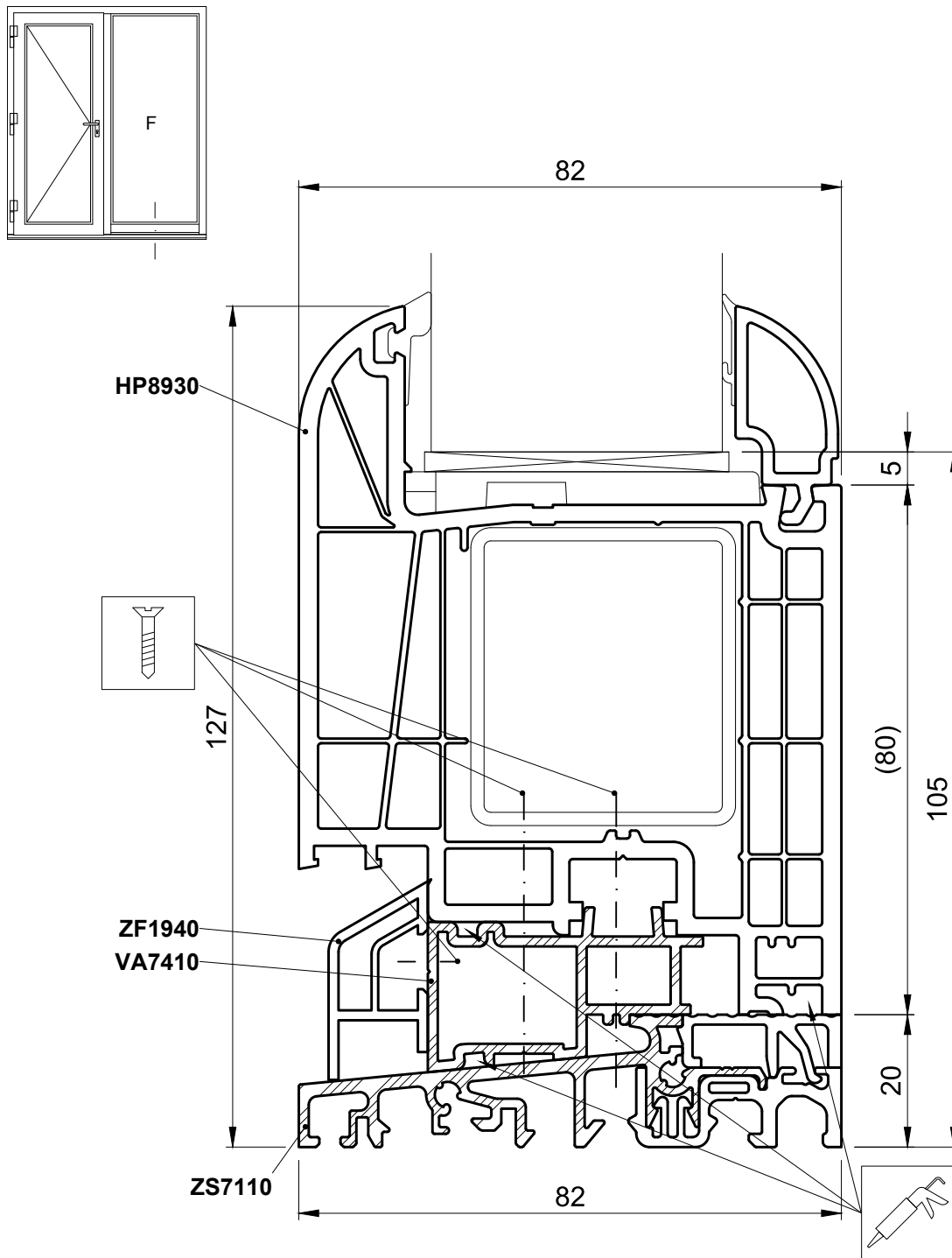

Door threshold  
**ZS7110**

Sash  
**HP8550**

Compensating piece  
**VA7410**

Weather profile strip  
**ZF1940**

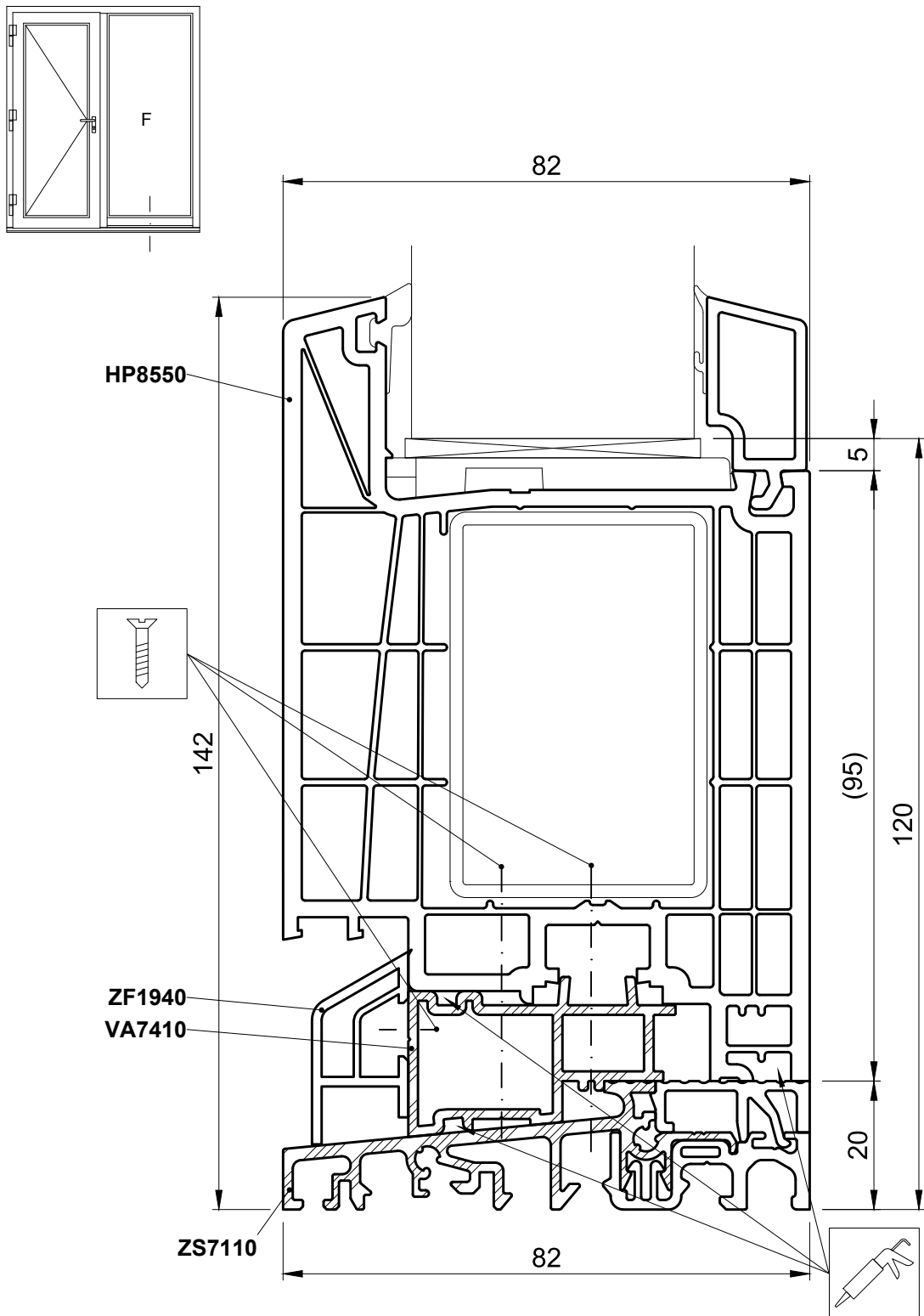

Door threshold  
ZS7130

Sash  
HO8520

Weather profile strip  
VA7231

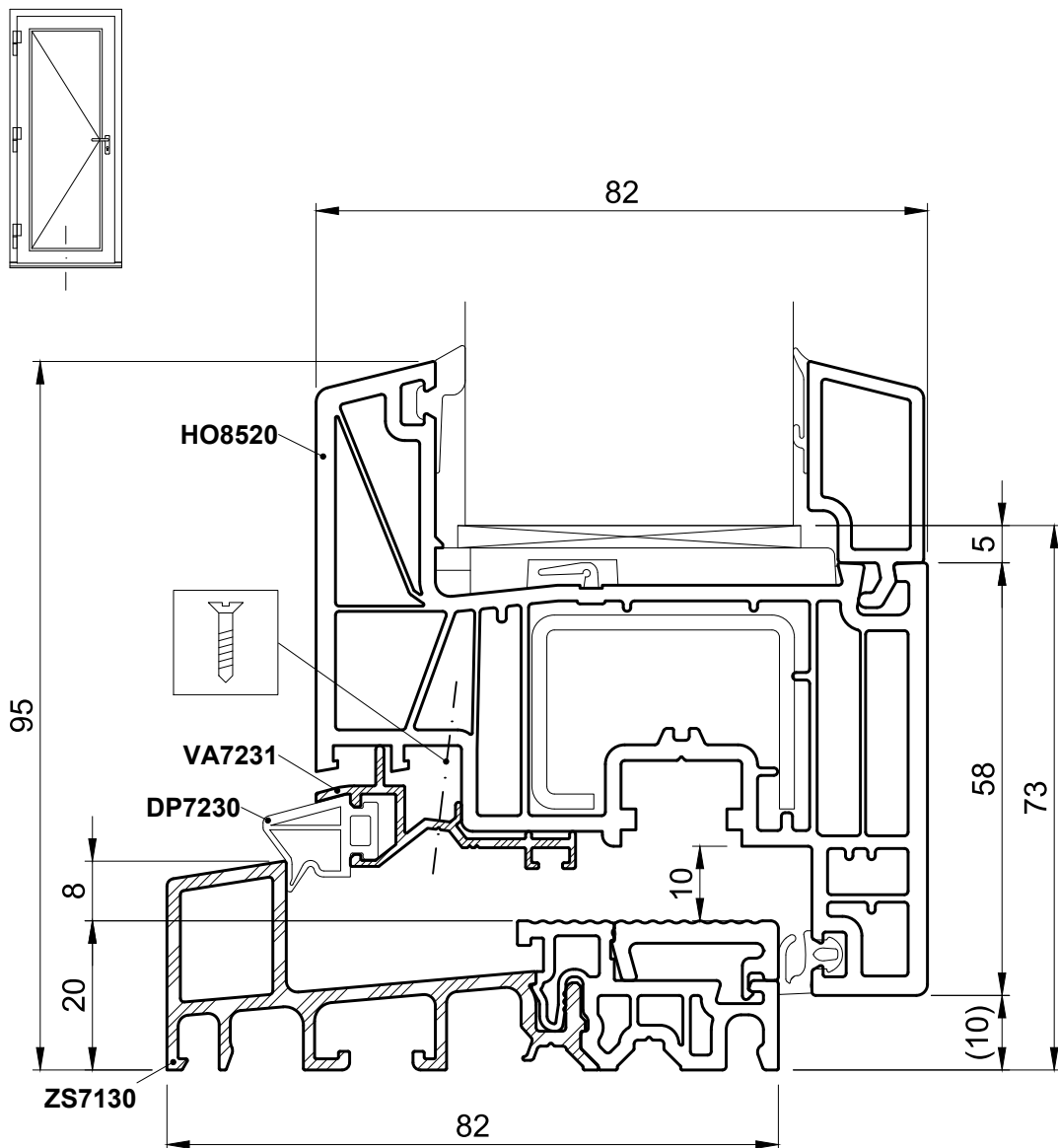

Door threshold  
**ZS7130**

Sash  
**HP8920**

Weather profile strip  
**VA7231**

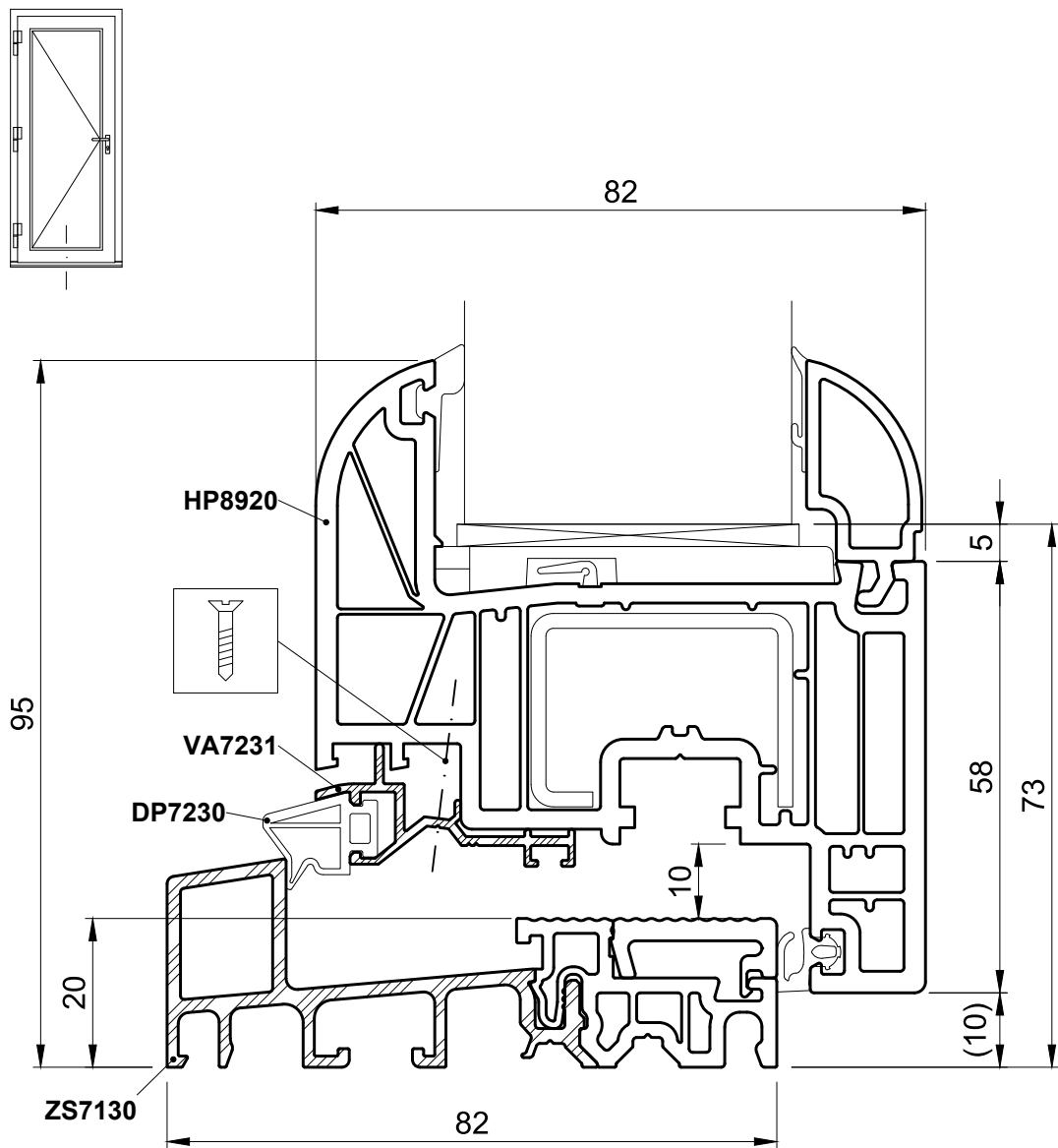

Door threshold  
ZS7130

Sash  
HO8530

Weather profile strip  
VA7231

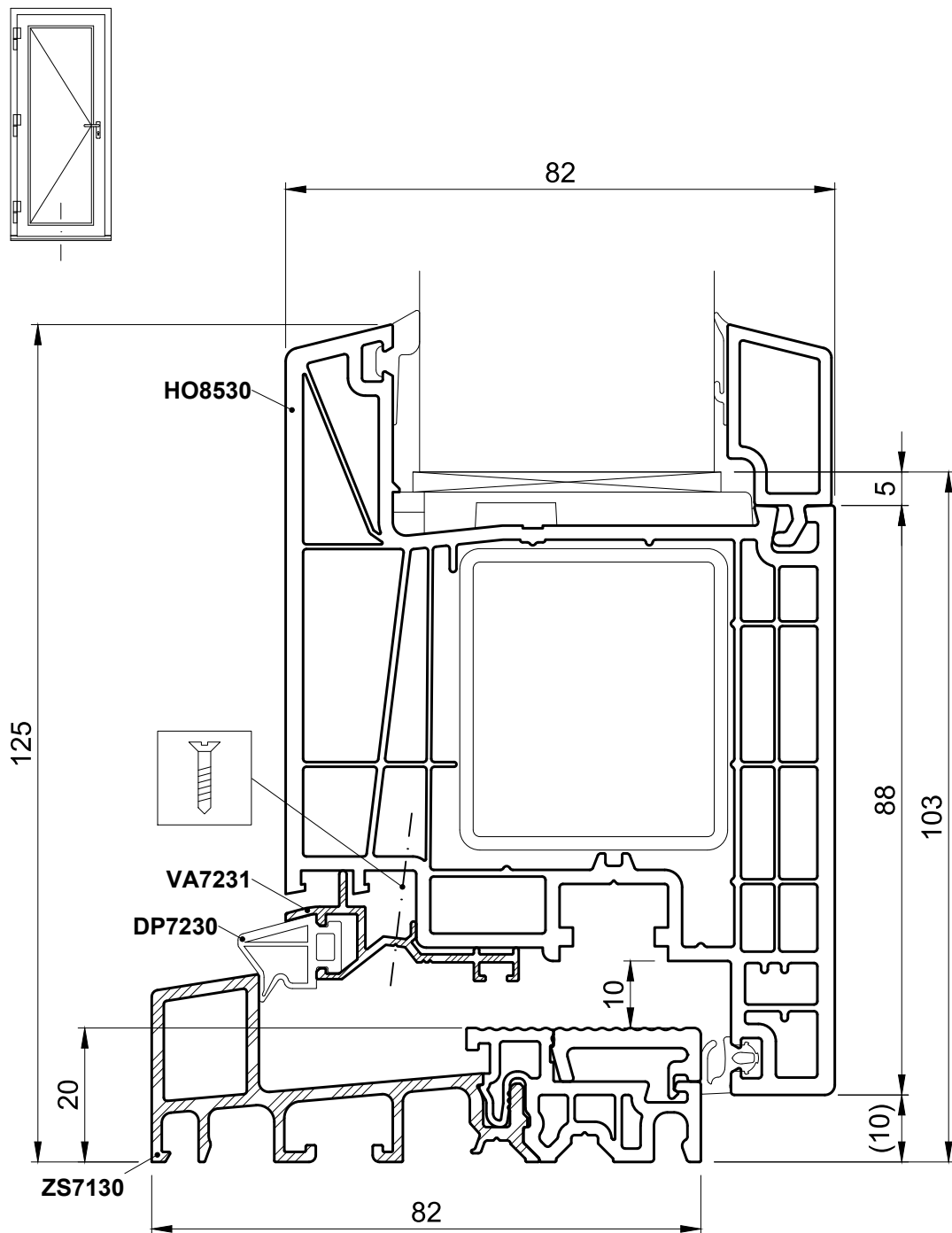

Door threshold  
**ZS7130**

Sash  
**HP8930**

Weather profile strip  
**VA7231**

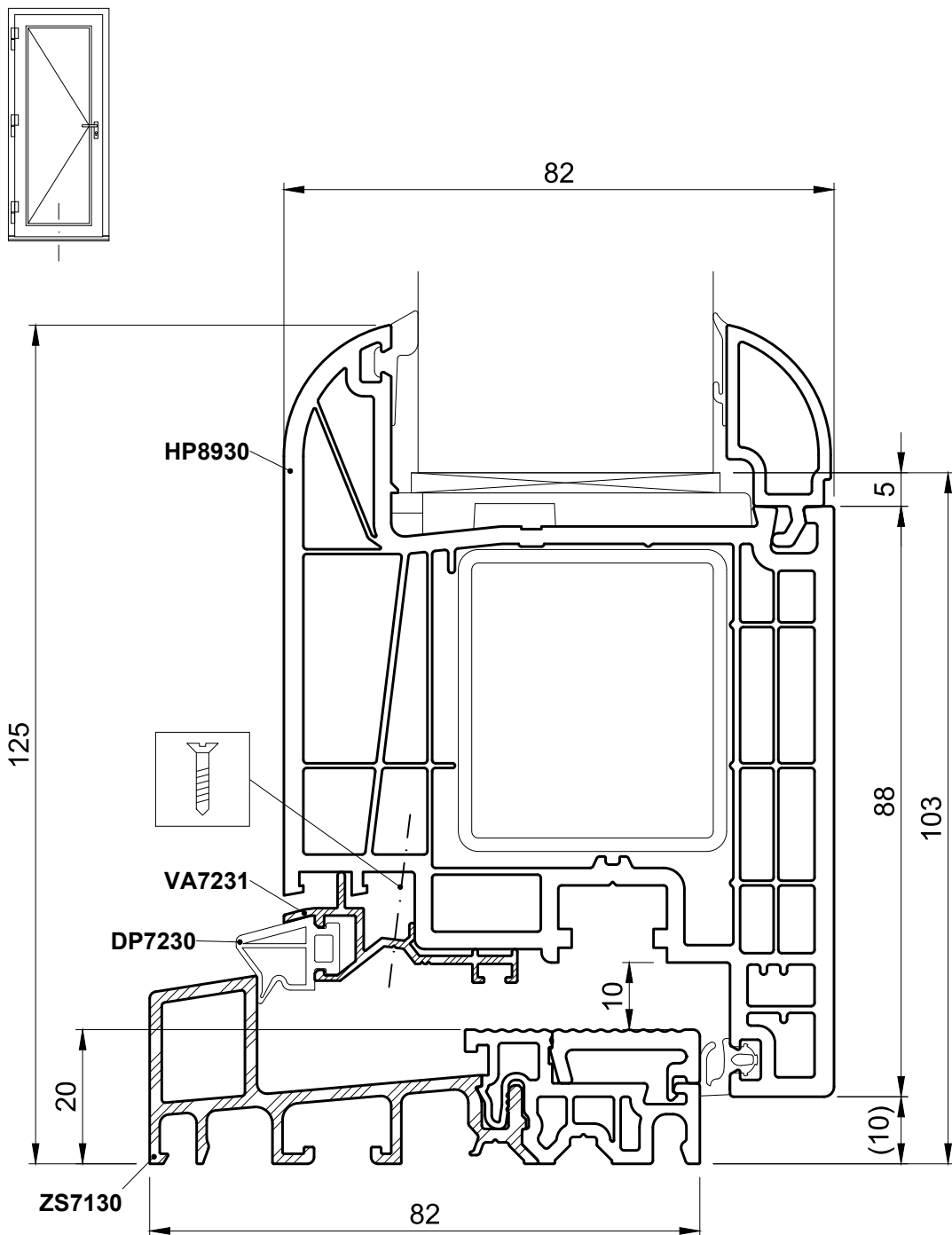

Door threshold  
ZS7130

Sash  
HP8550

Weather profile strip  
VA7231

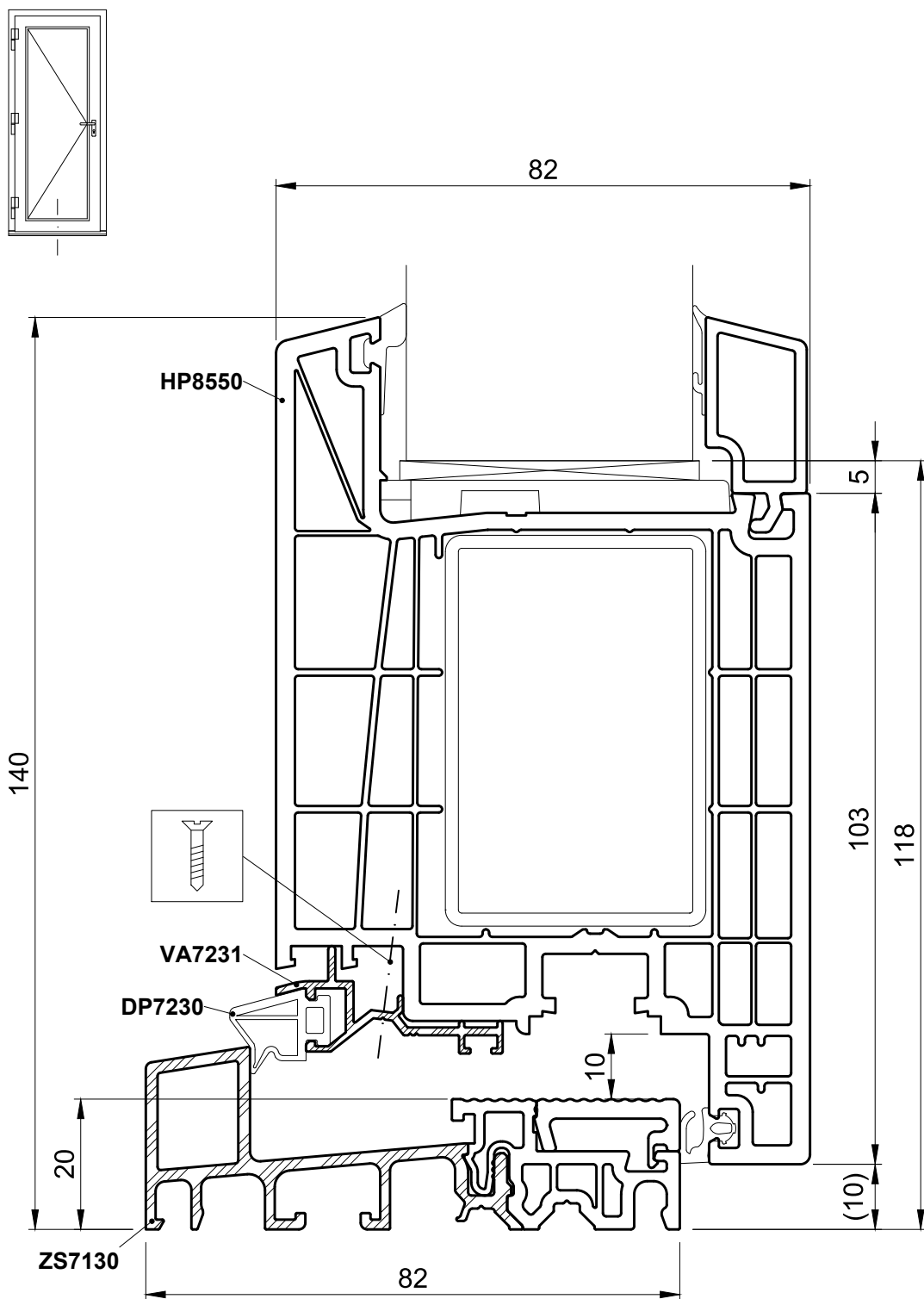

Door threshold  
**ZS7130**

Sash  
**HO8580**

Weather profile strip  
**VA7231**

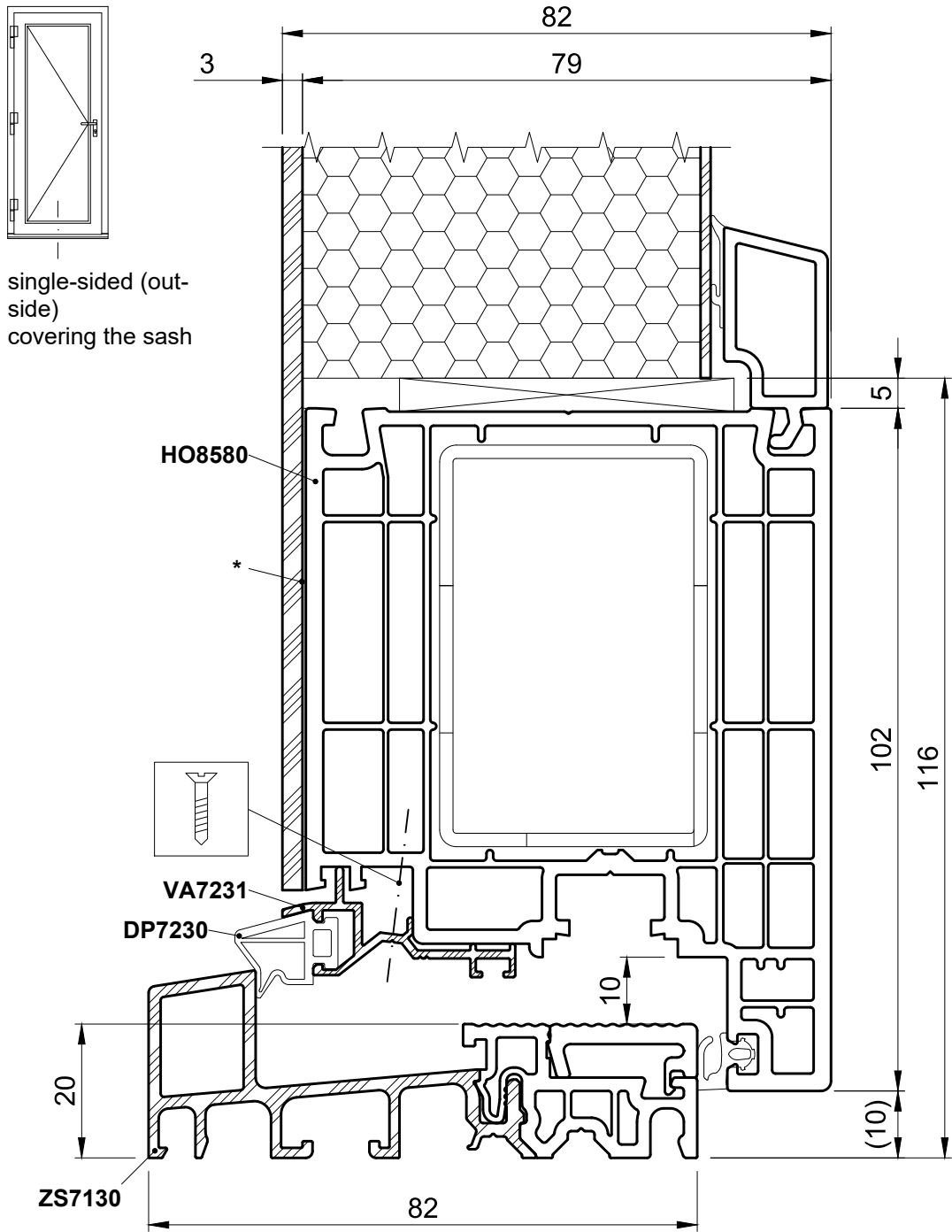

Door threshold  
ZS7130

Sash  
HO8580

Weather profile strip  
VA7231

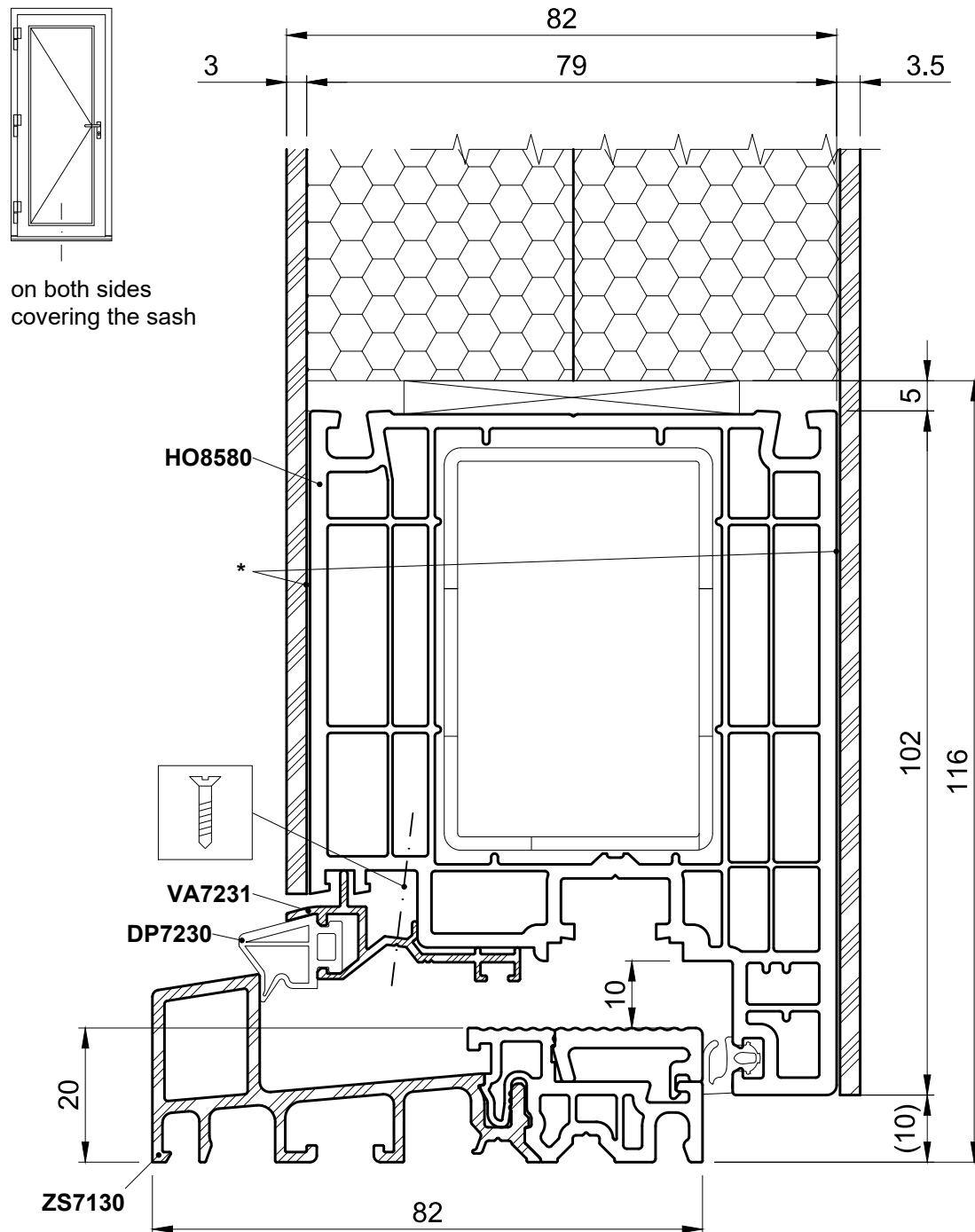

Frame  
HO8020

fixed side part top  
HP8550

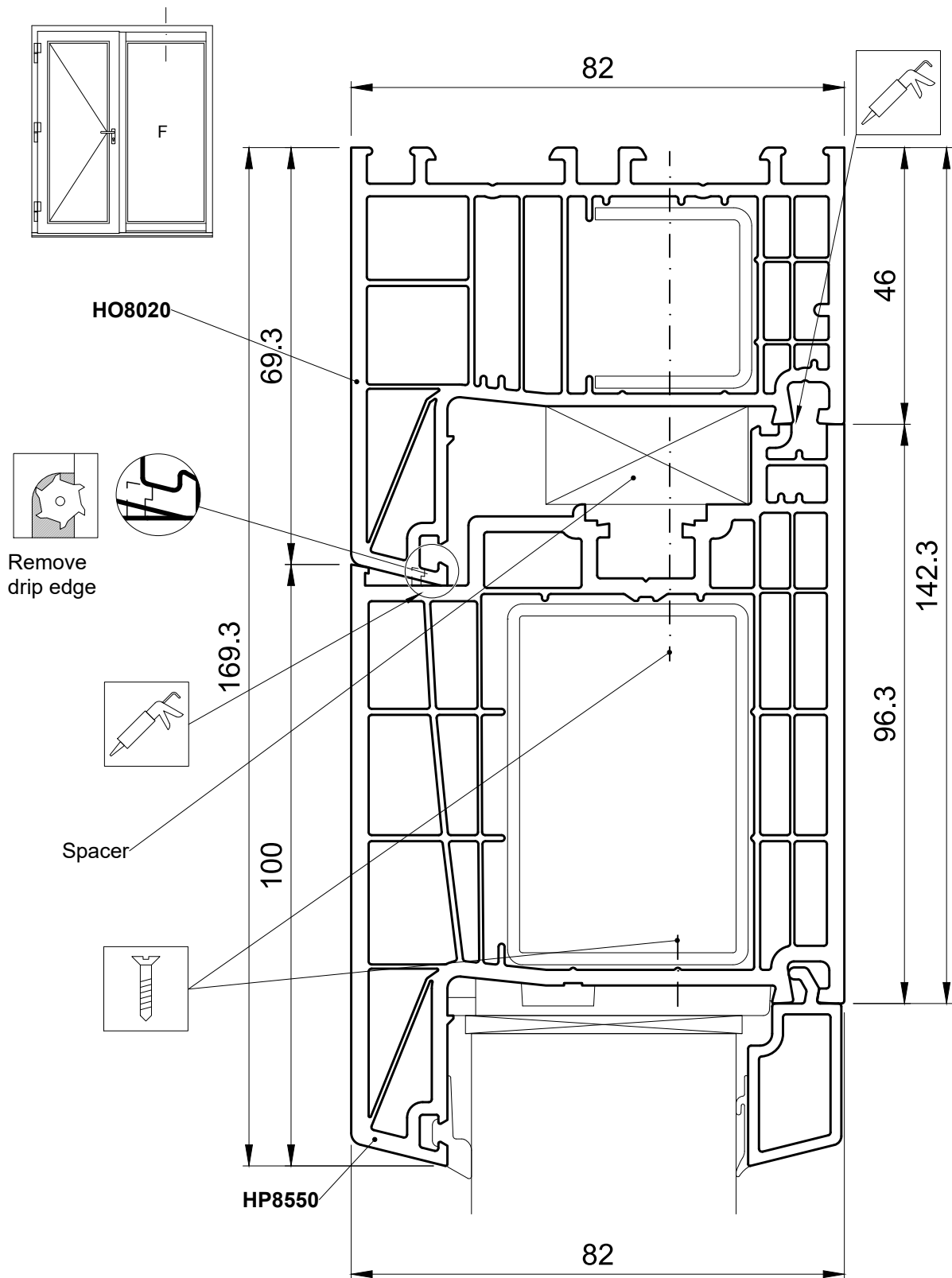

Frame  
HO8020

fixed side part top  
HP8550

**i** INFO

- ▶ Produce your own spacer from suitable material.

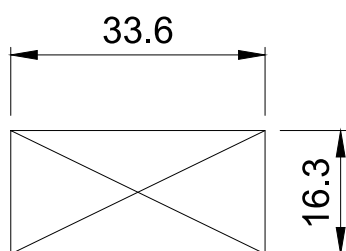

Door threshold  
**ZS7110**

Widenings  
**NP1120, NP1350, NP1550, NP3300**

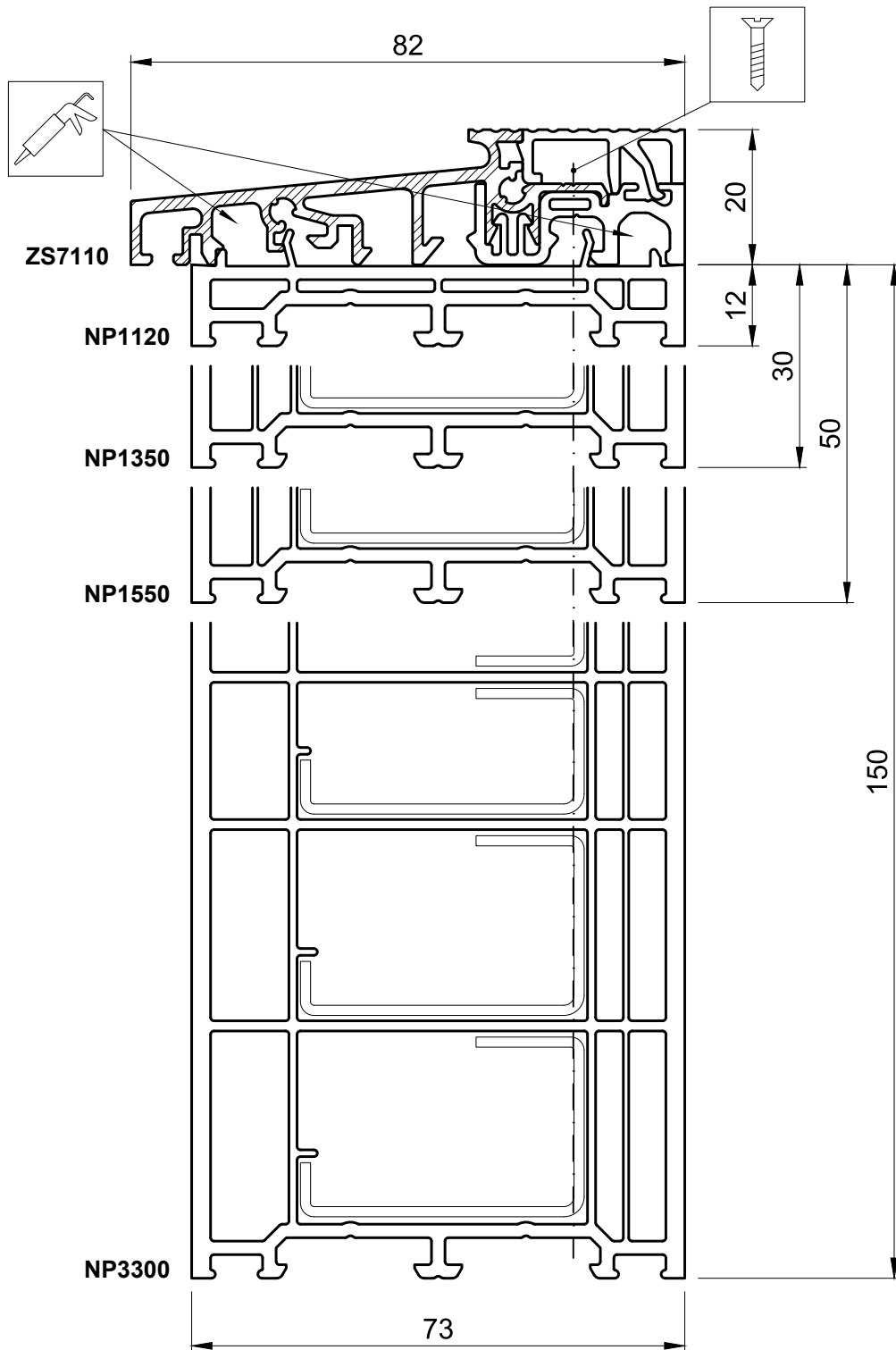

Door threshold  
ZS7110

Widening  
NP3280

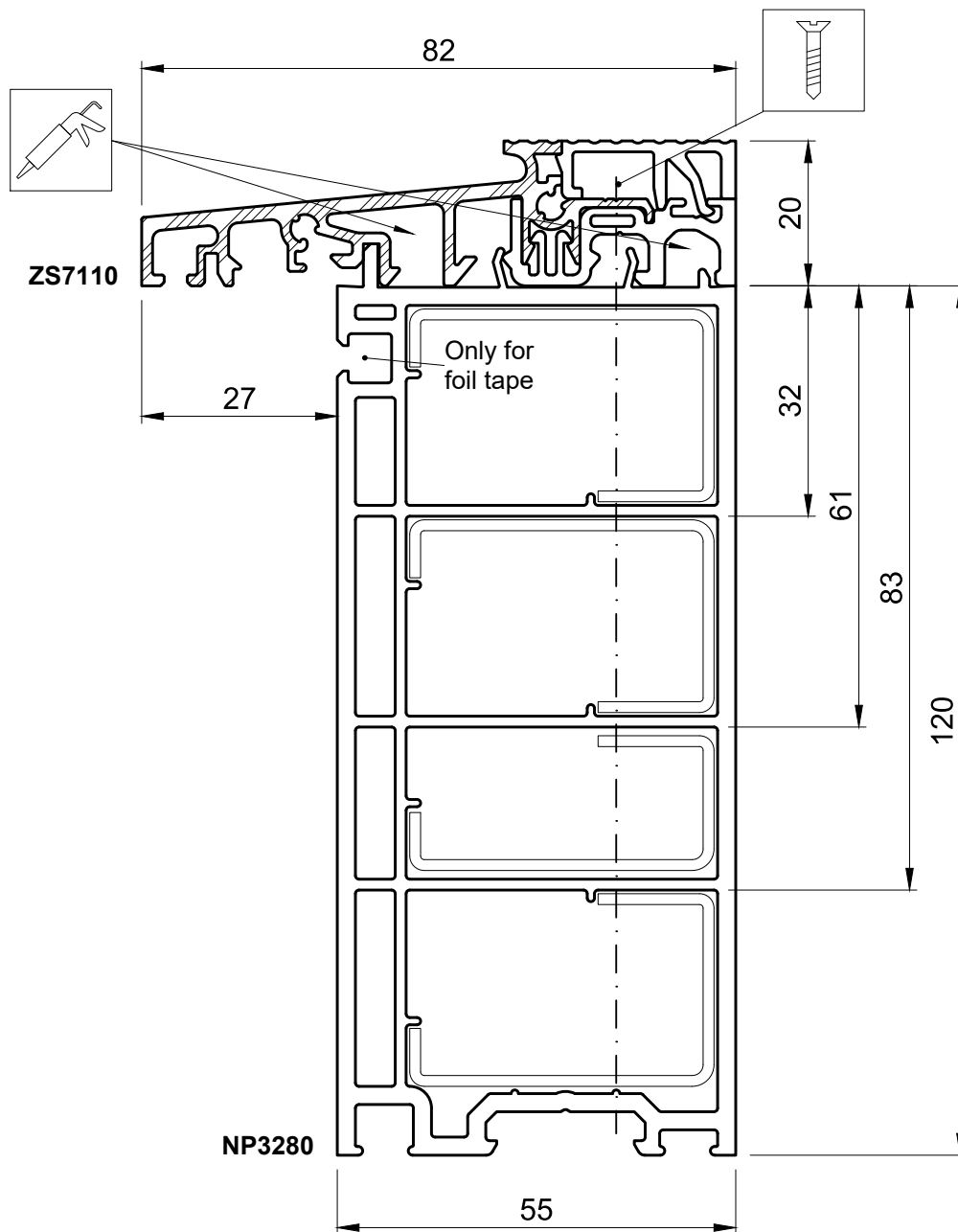

Door threshold  
**ZS7110**

Widening  
**NP8280**

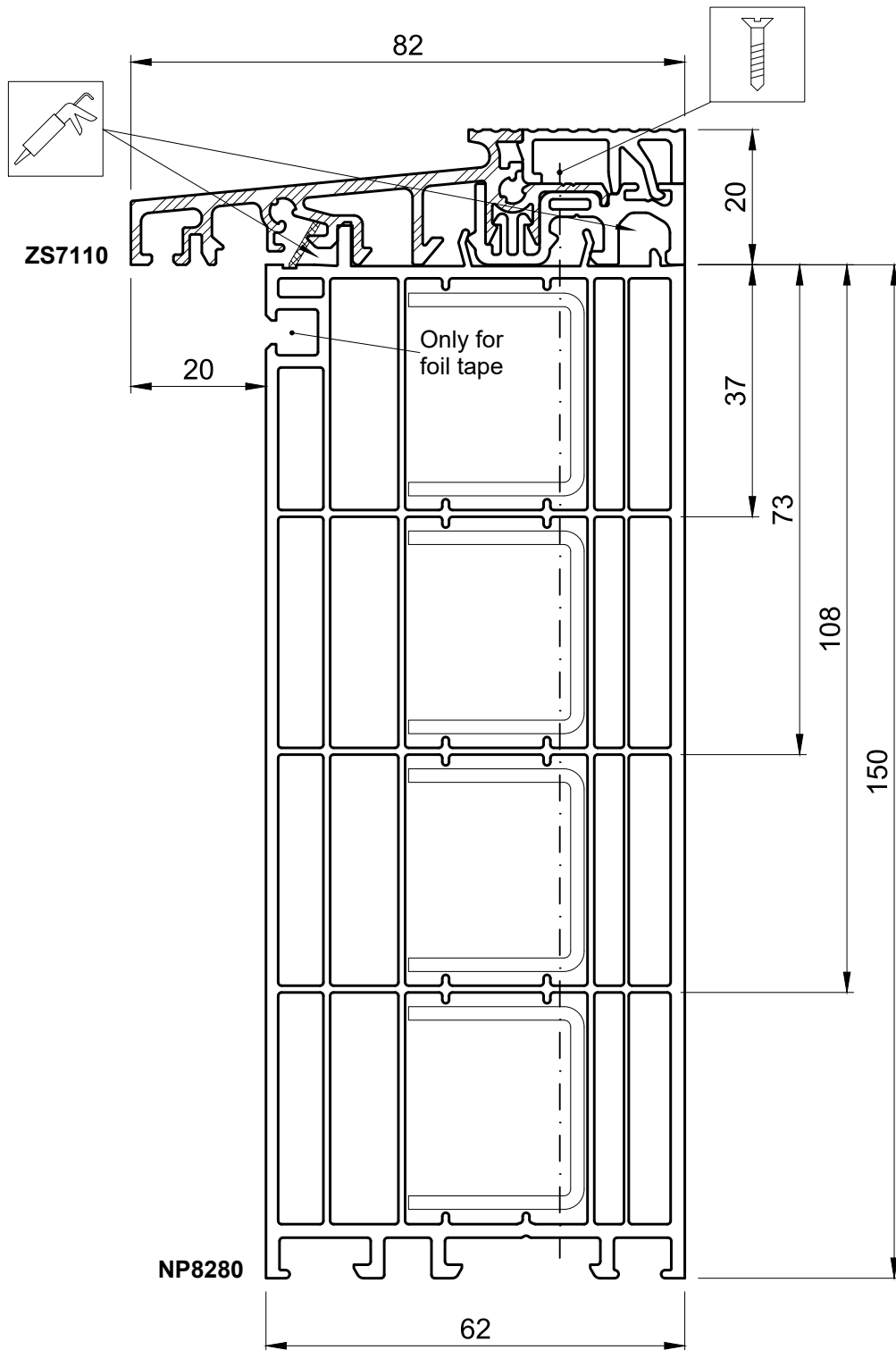

Rebate reinforcement

MT8500

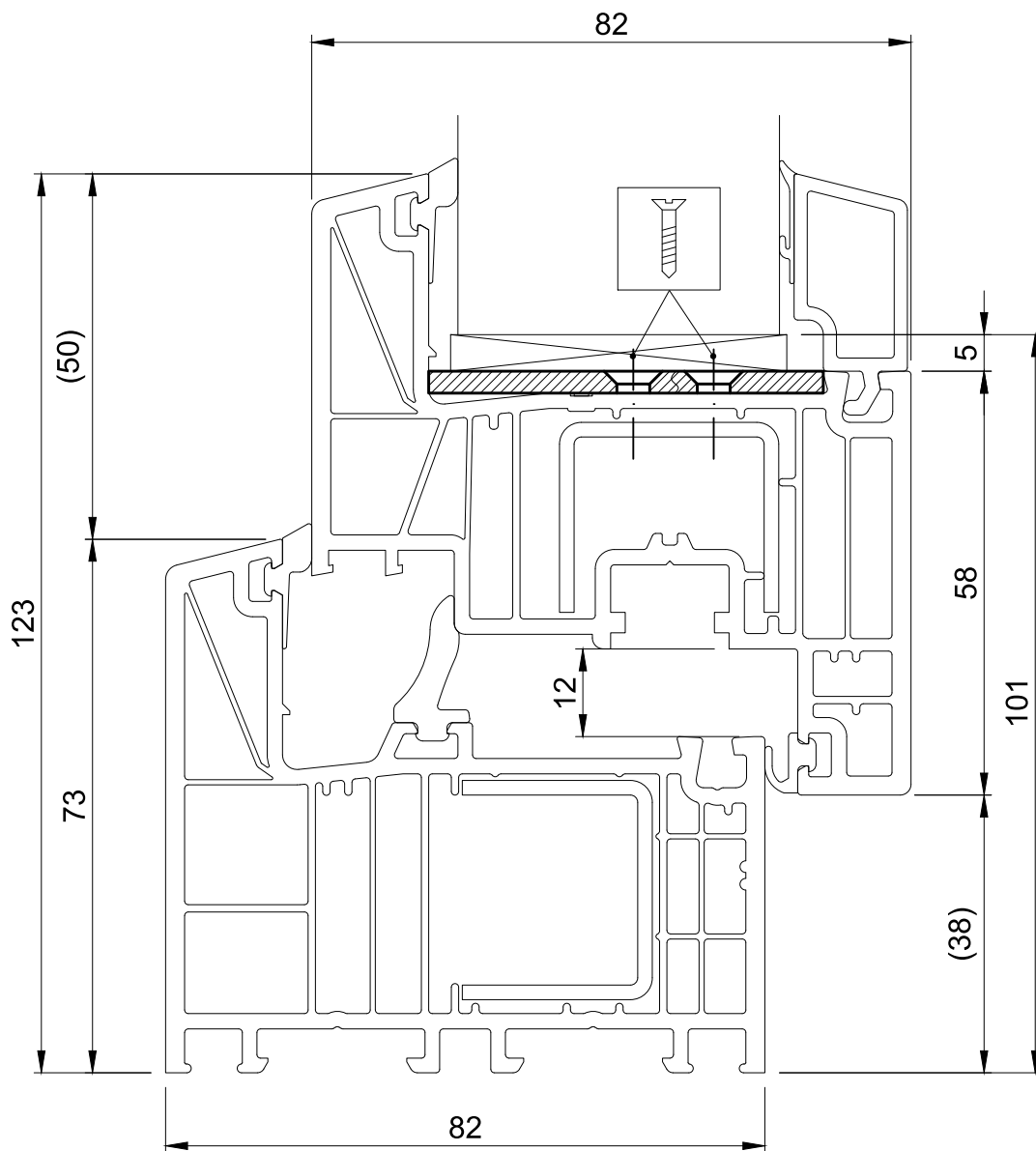

**i** INFO

Application only vertically

Rebate corner angle

438566

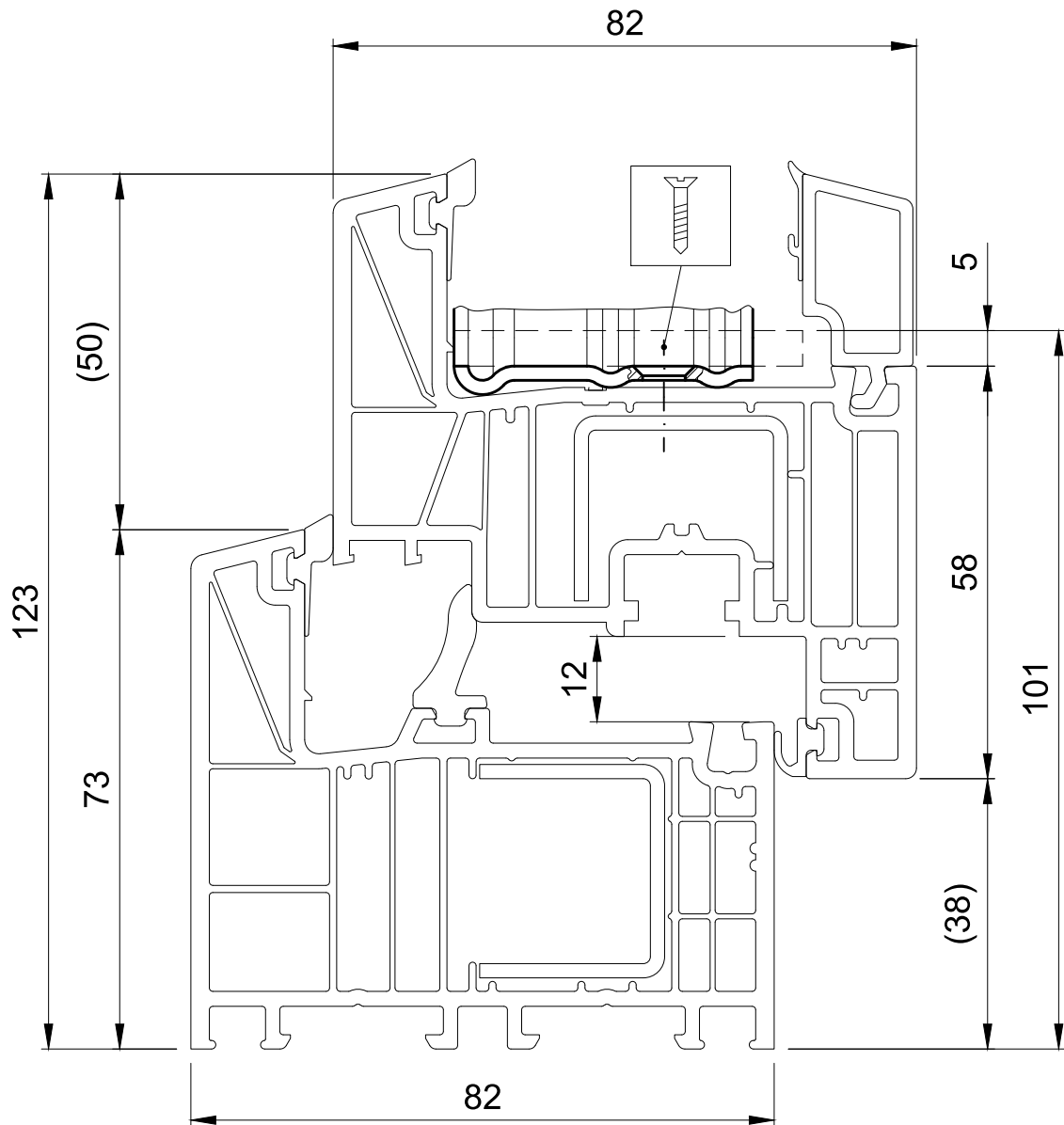

**i** INFO

Application in corner areas

Widenings

NP8200, NP8300, NP8500, NP8700

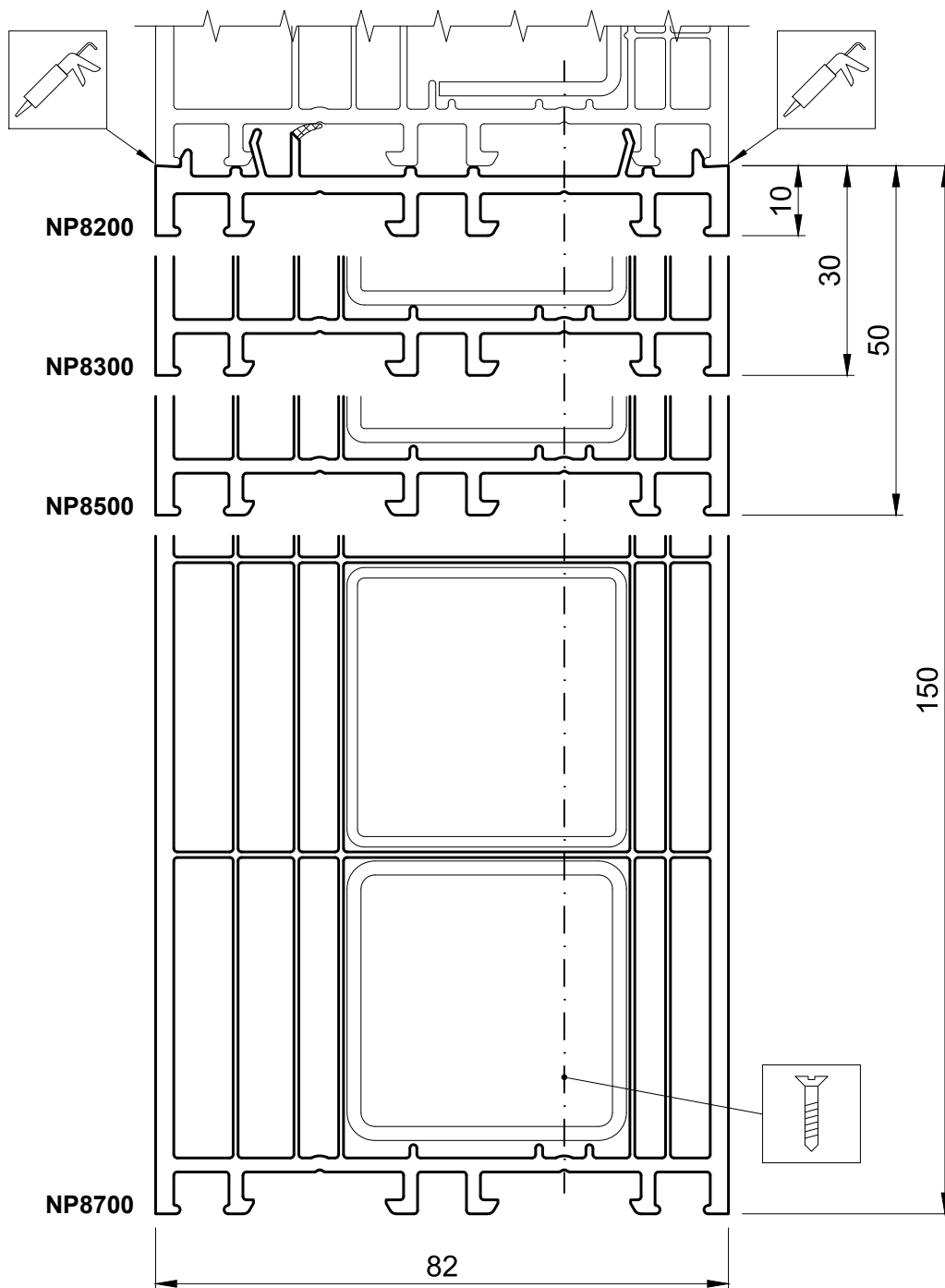

Widening

NP3280

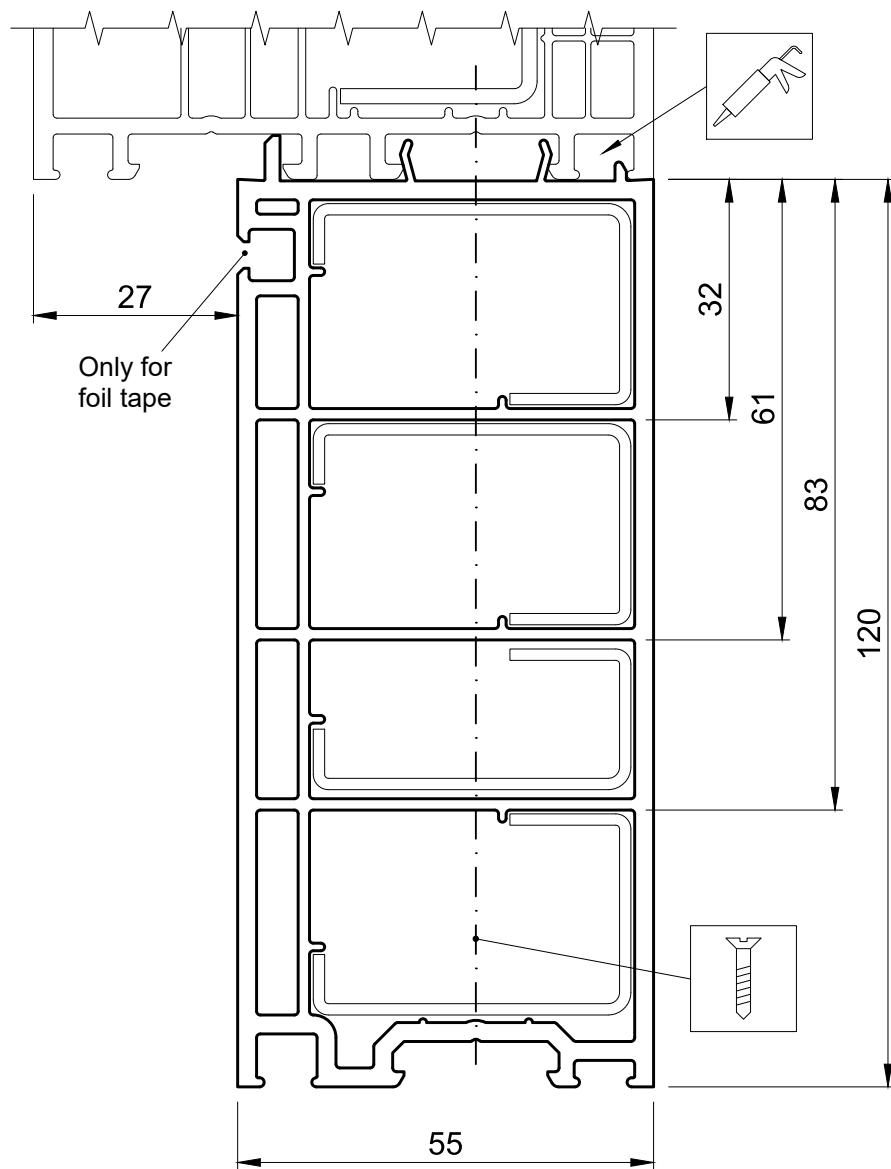

Widening

NP8280

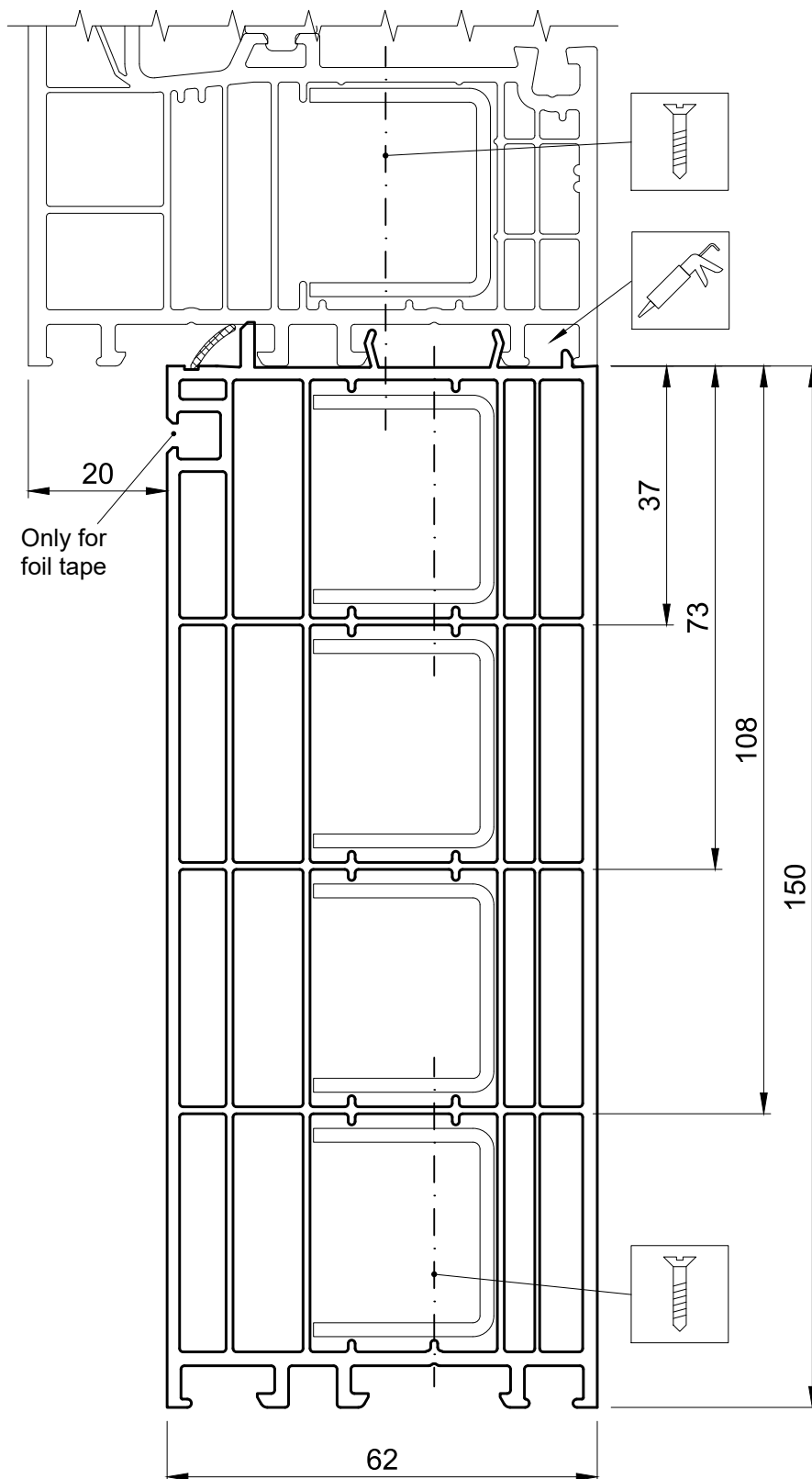

External sill connections

**NP0300, NP0320**

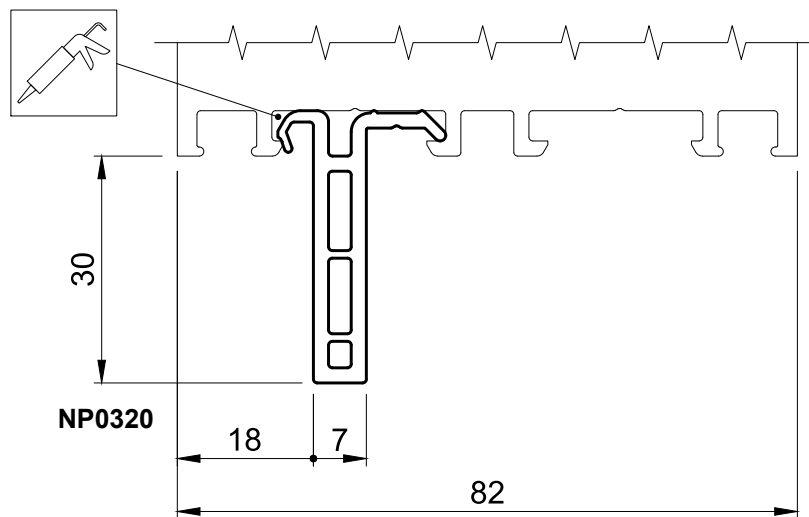
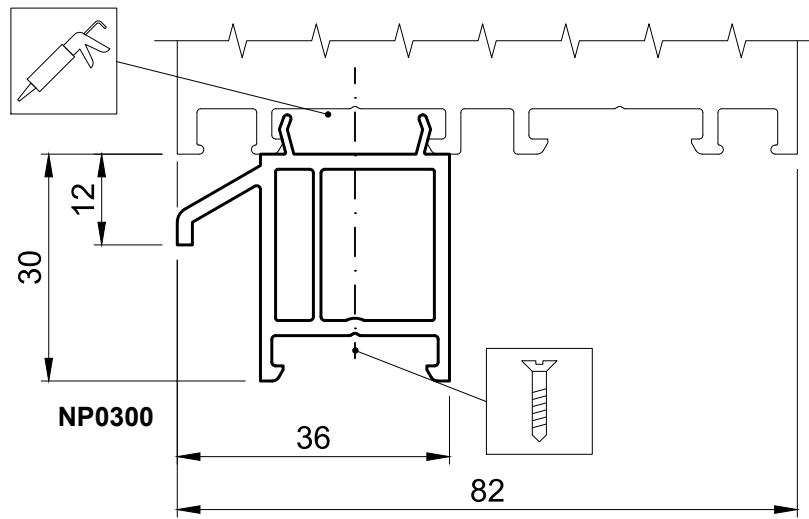

External sill connections

NP0360, NP0370

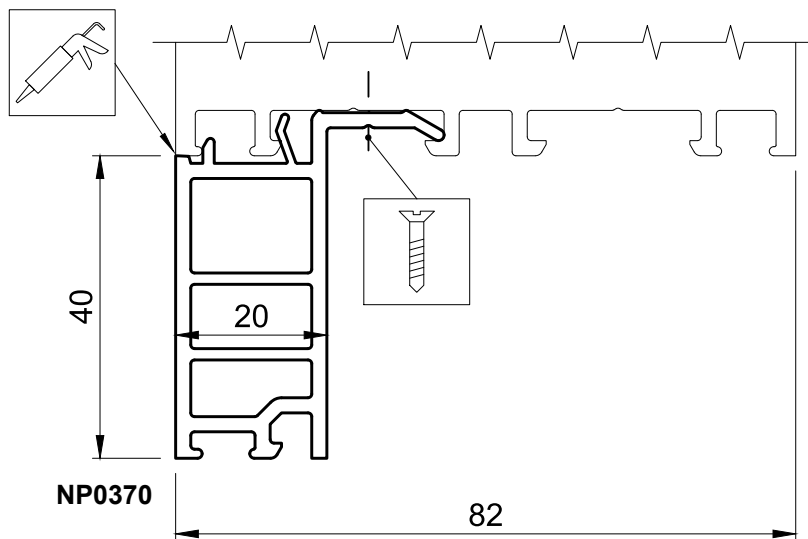
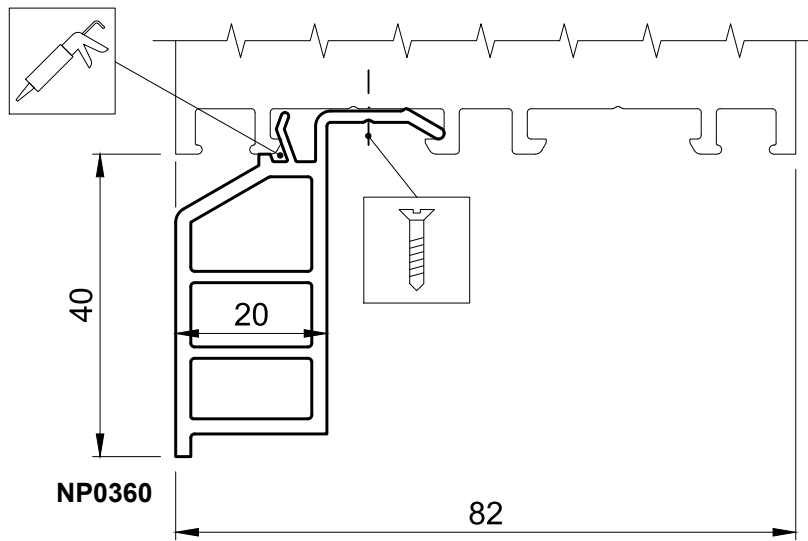

External sill connections

**NP0380, NP0400**

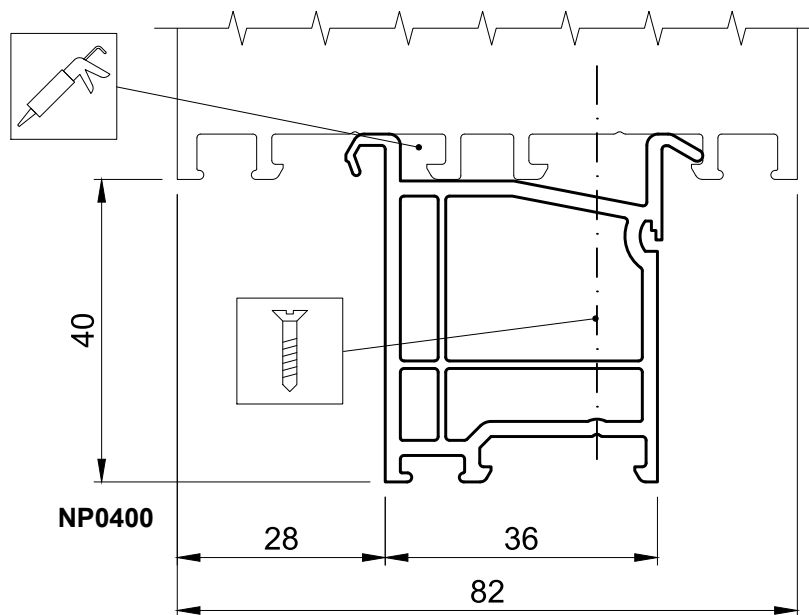
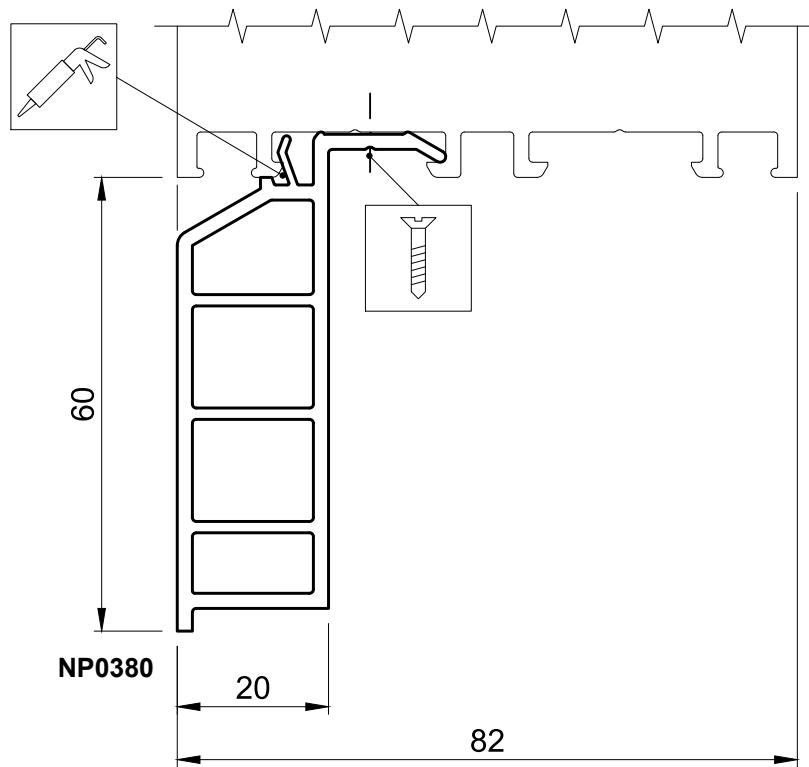

External sill connection

Window sill connection

416119

NP8020

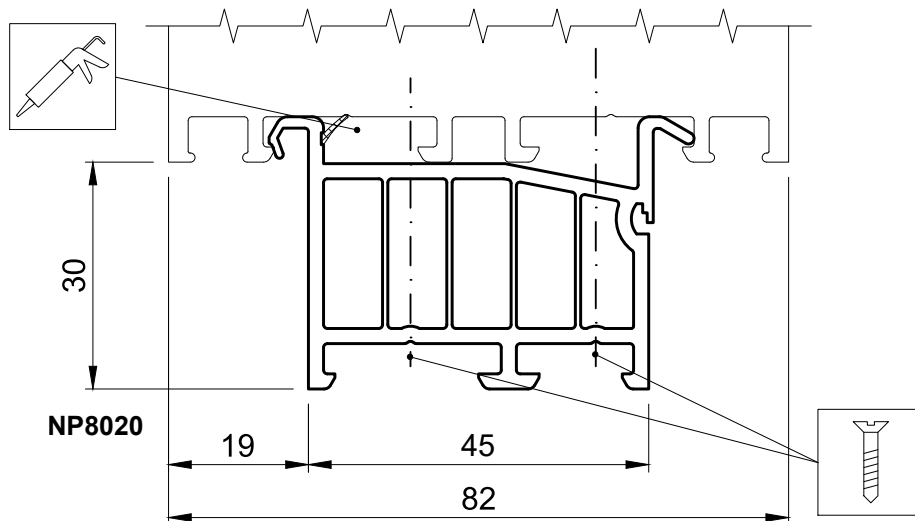
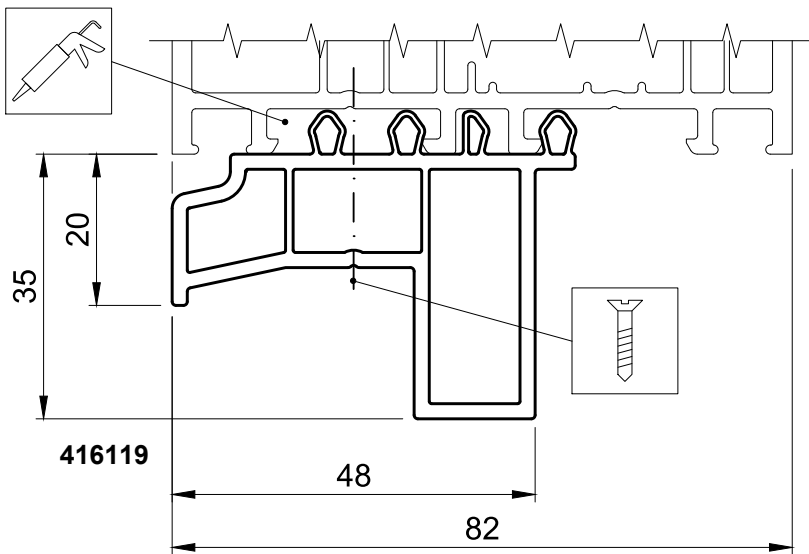

Window sill connections

**NP0770, NP0960**

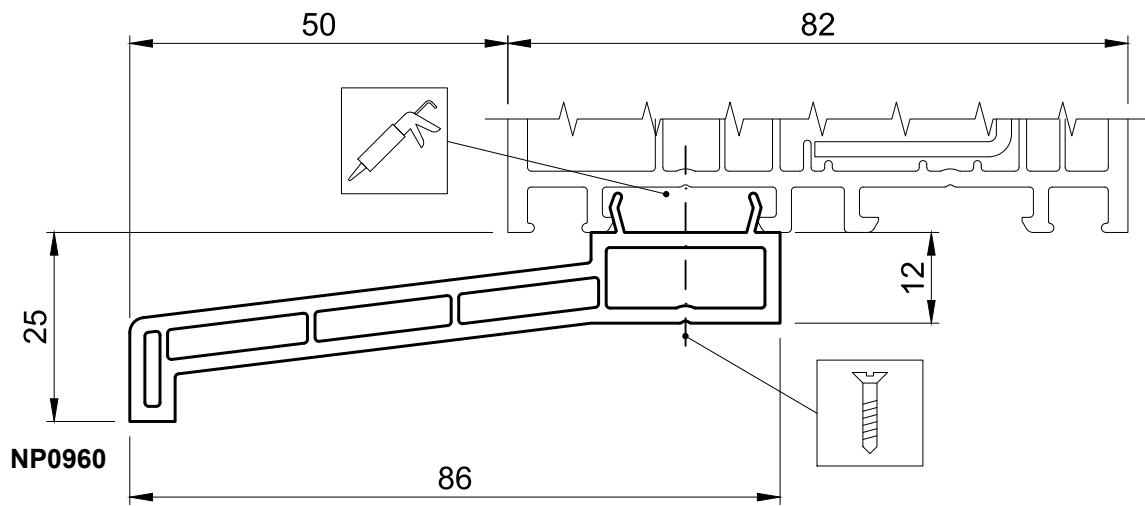
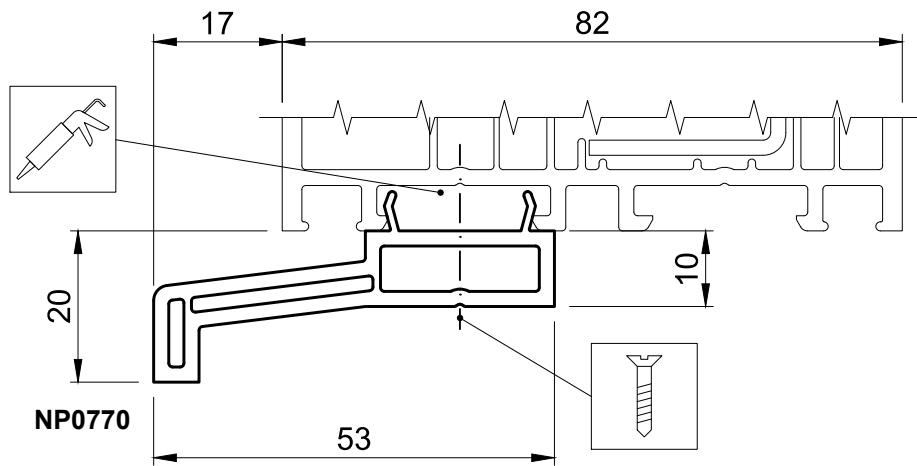

Coupling profile, vertical

NP0190

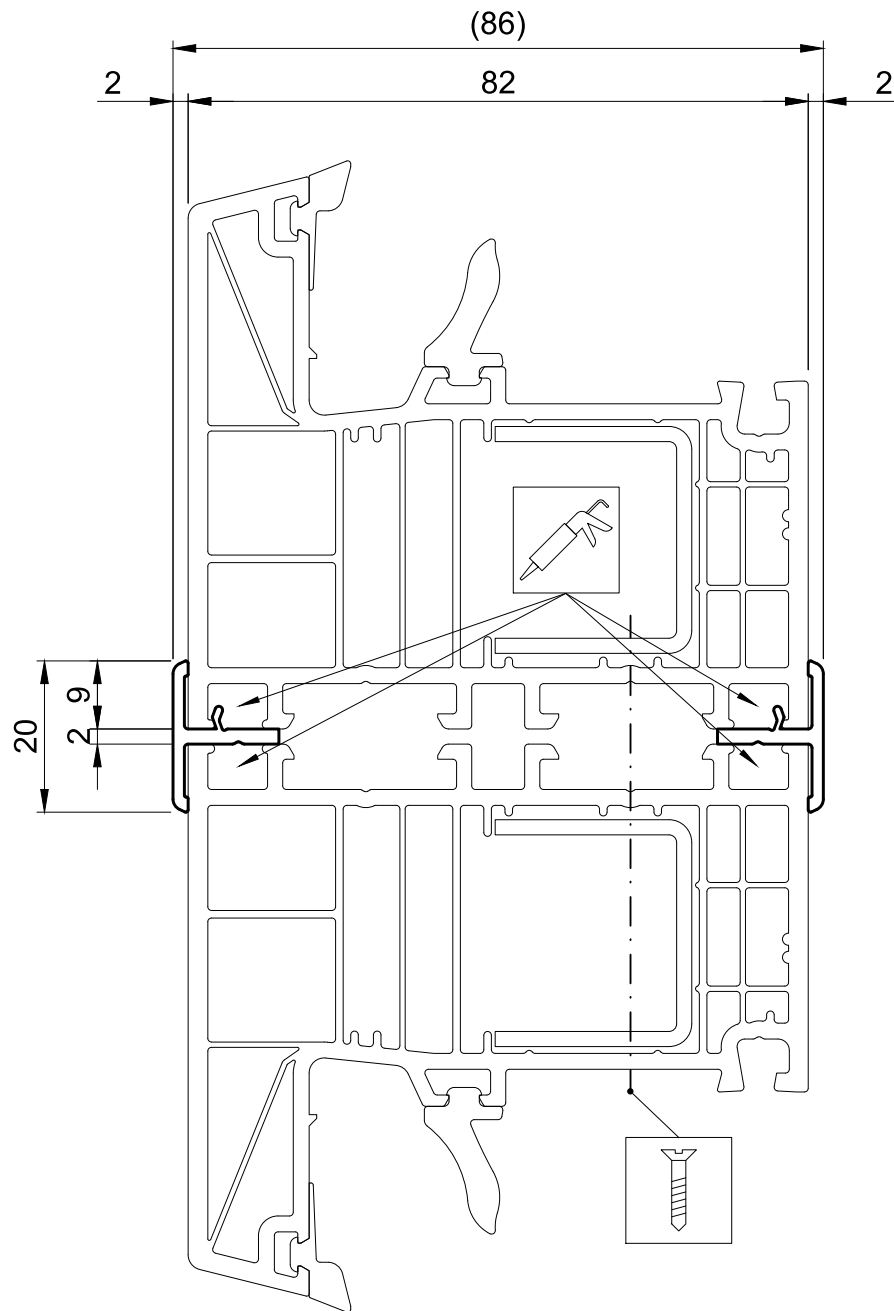
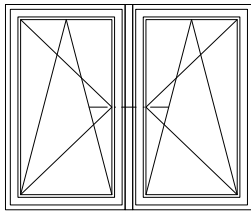

**i** INFO

Application only vertically

Coupling professional, vertical  
**NP8110**

Cover  
**406340**

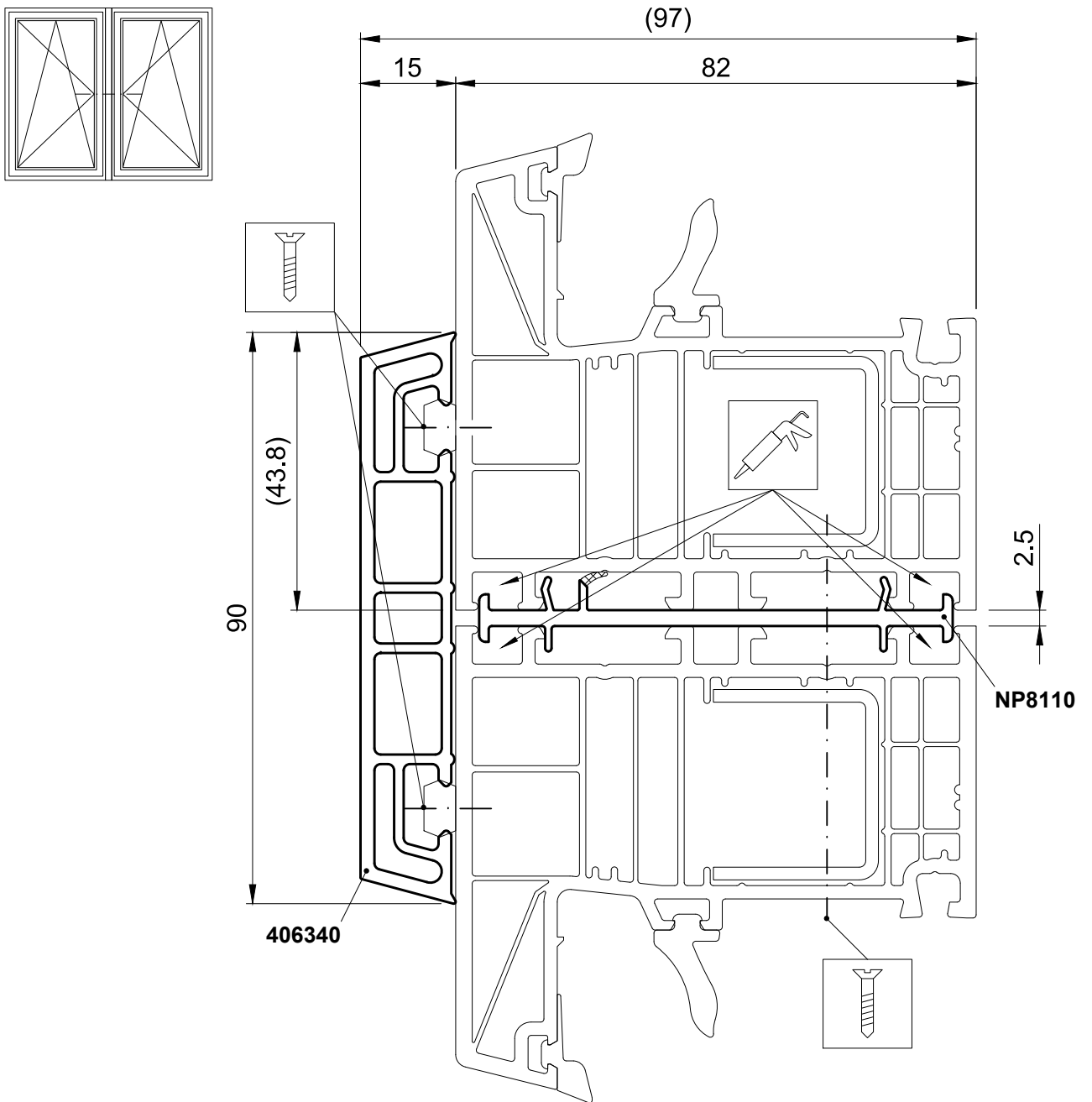

**i** INFO

Application only vertically

Coupling profile, vertical

NP8120

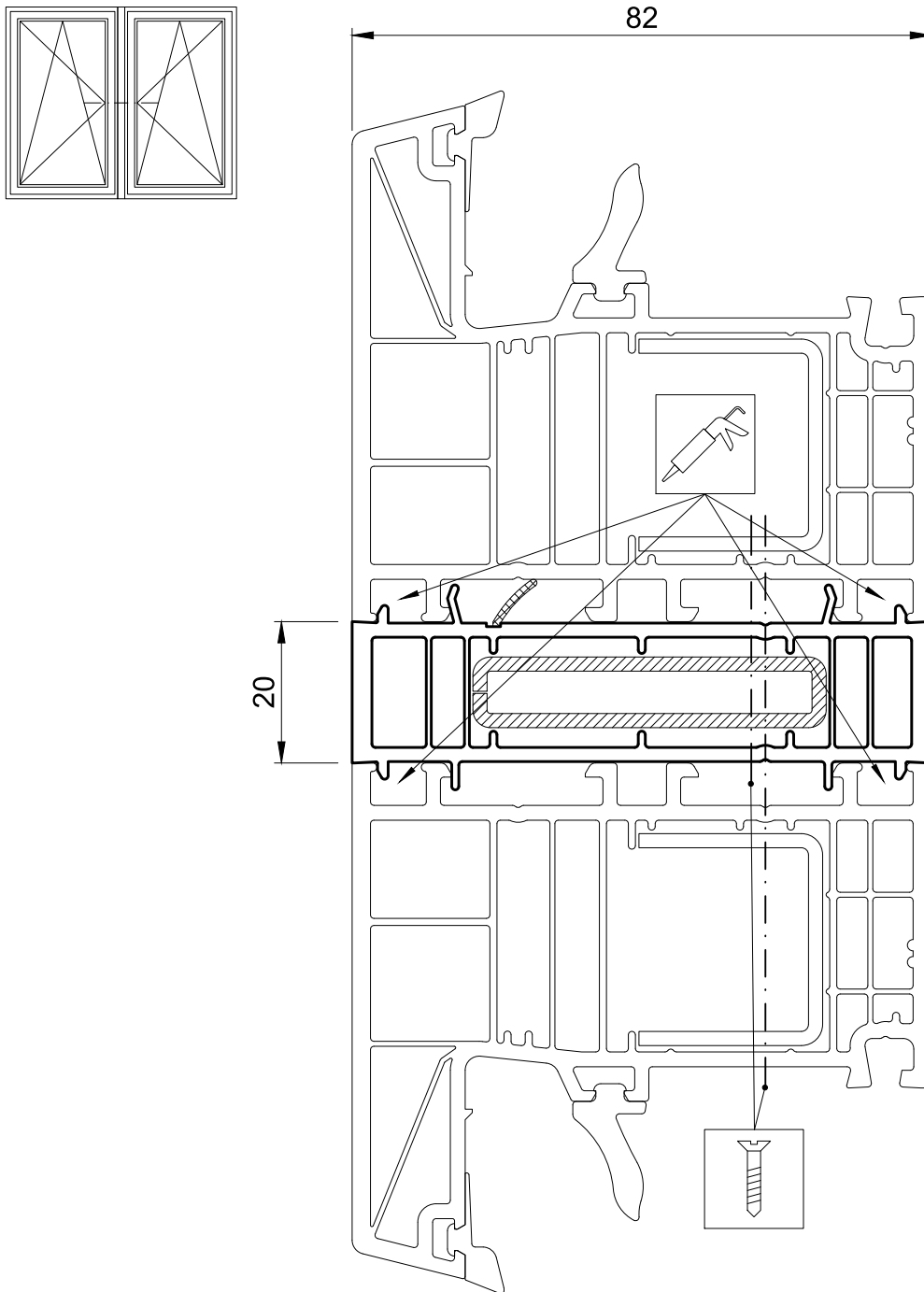

**i** INFO

Application only vertically

Coupling profile, horizontal

**NP8120**

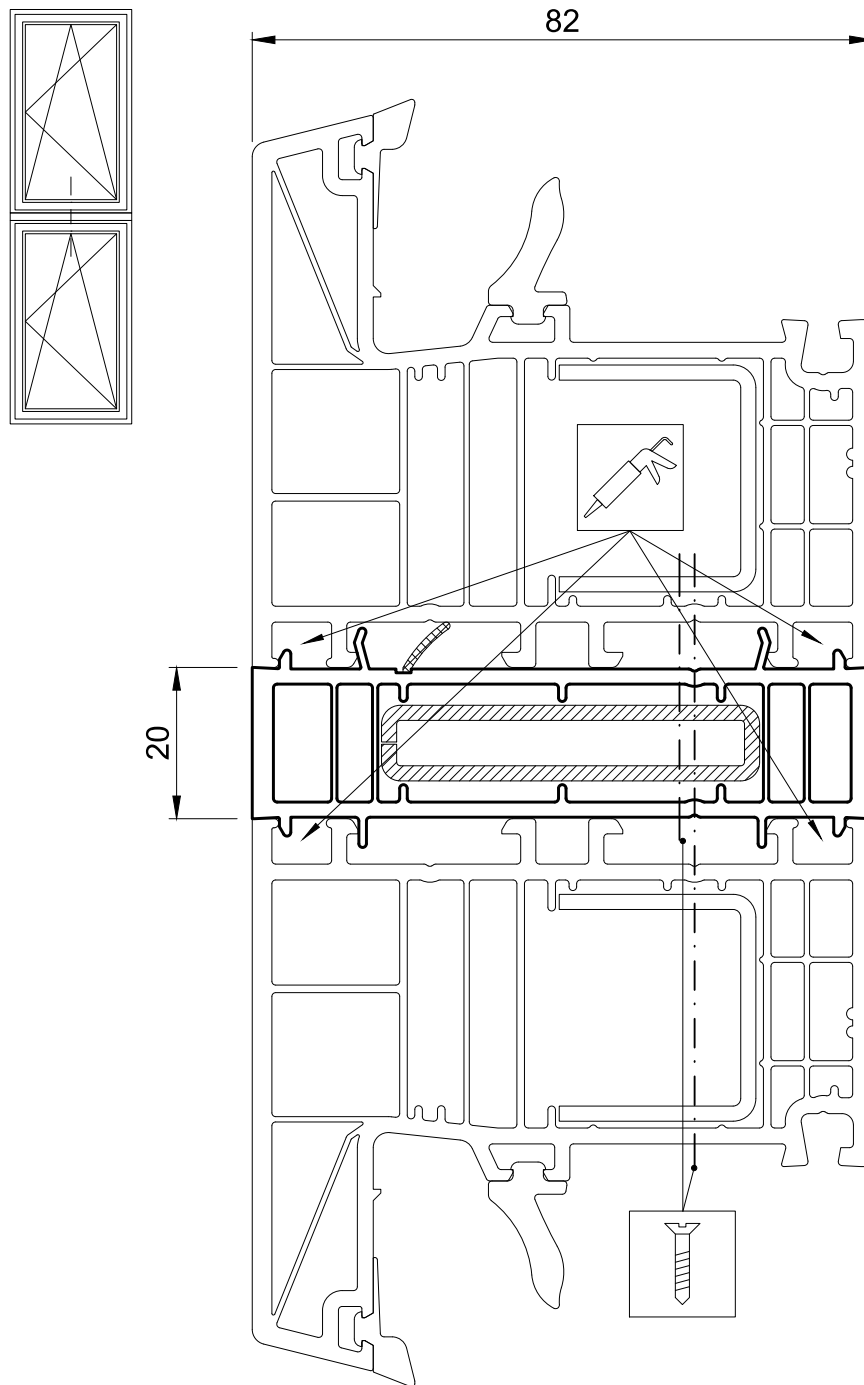

**i** INFO

Application horizontal.

Capillary joints and lateral connections to the building must be sealed professionally.

Coupling profile, vertical, without expansion joint

NP8170

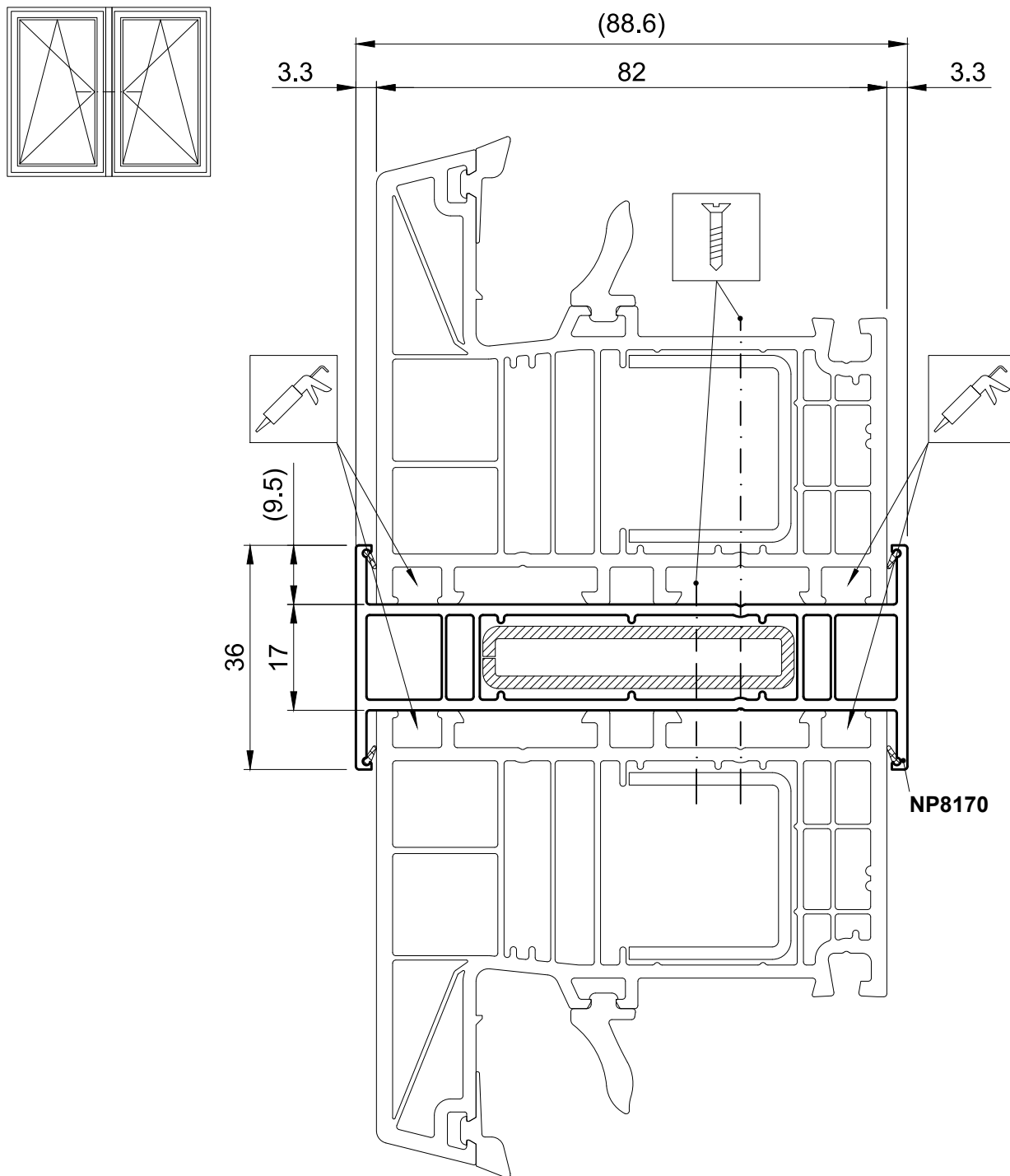

**i** INFO

Application only vertically

Coupling profile, vertical, with expansion joint  
**NP8170**

Spacer  
**MT8140**

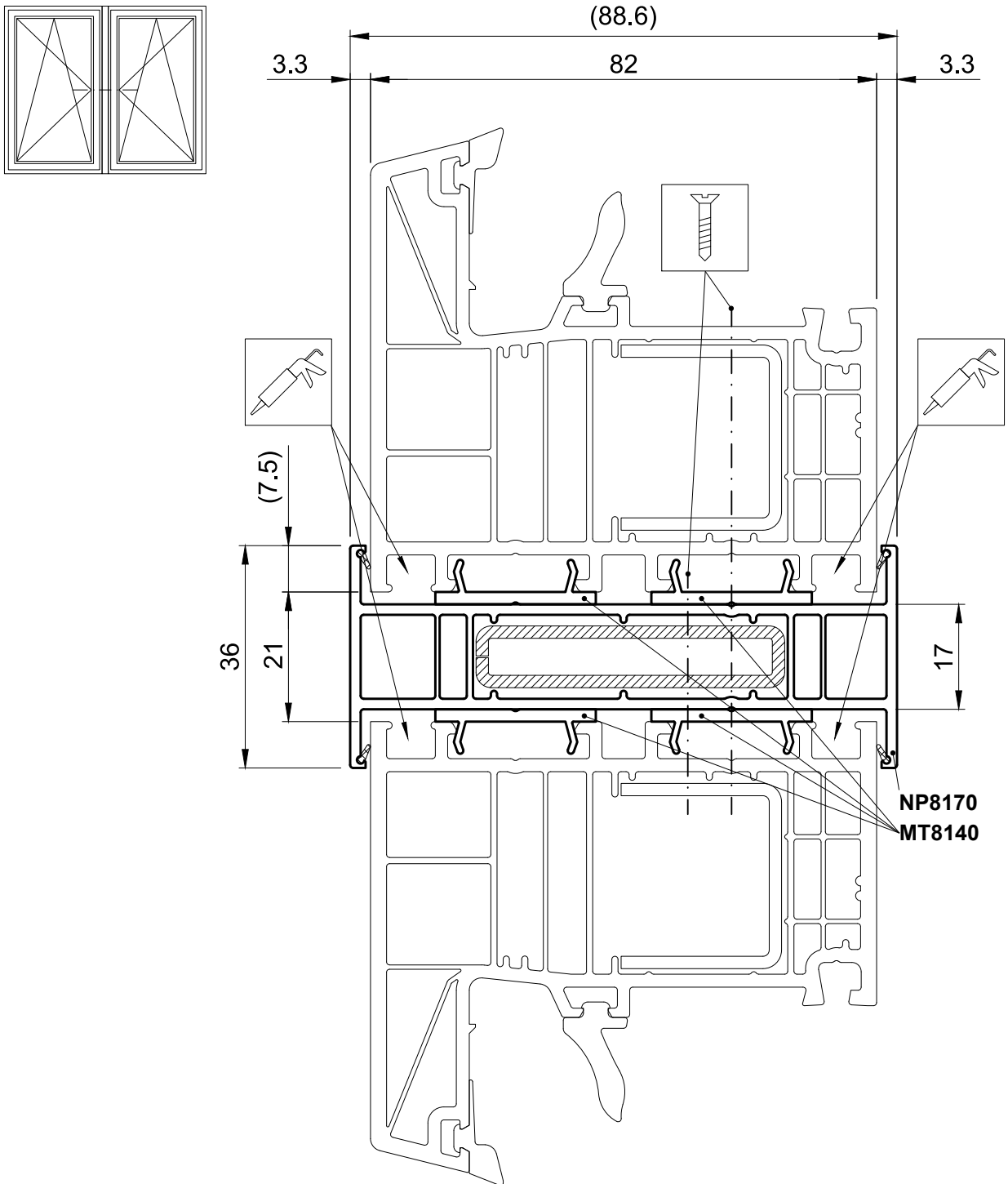

**i** INFO

Application only vertically

Corner connection, 90°  
NP0100

Insulation strip  
417810

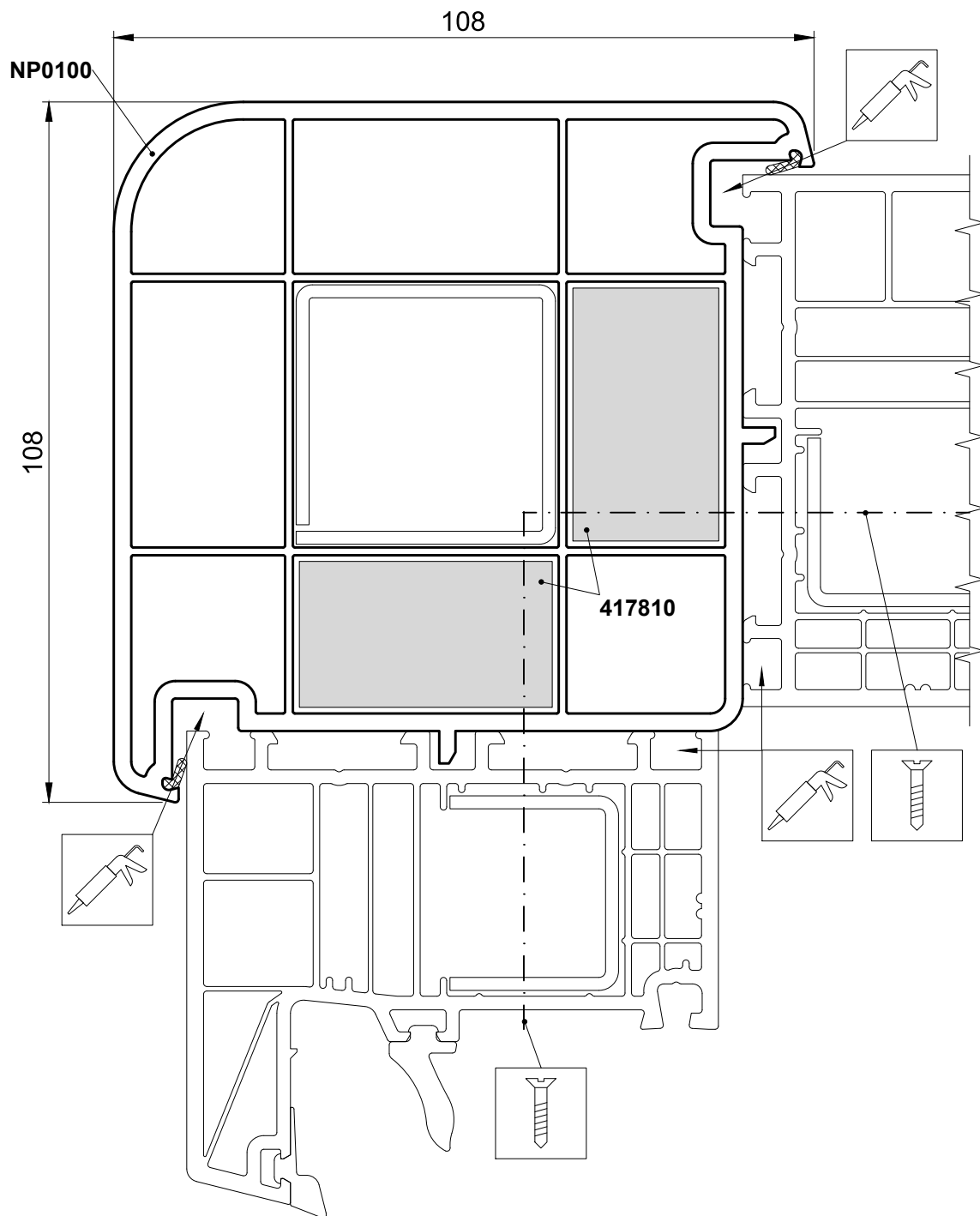

Corner connection, 135°

416240

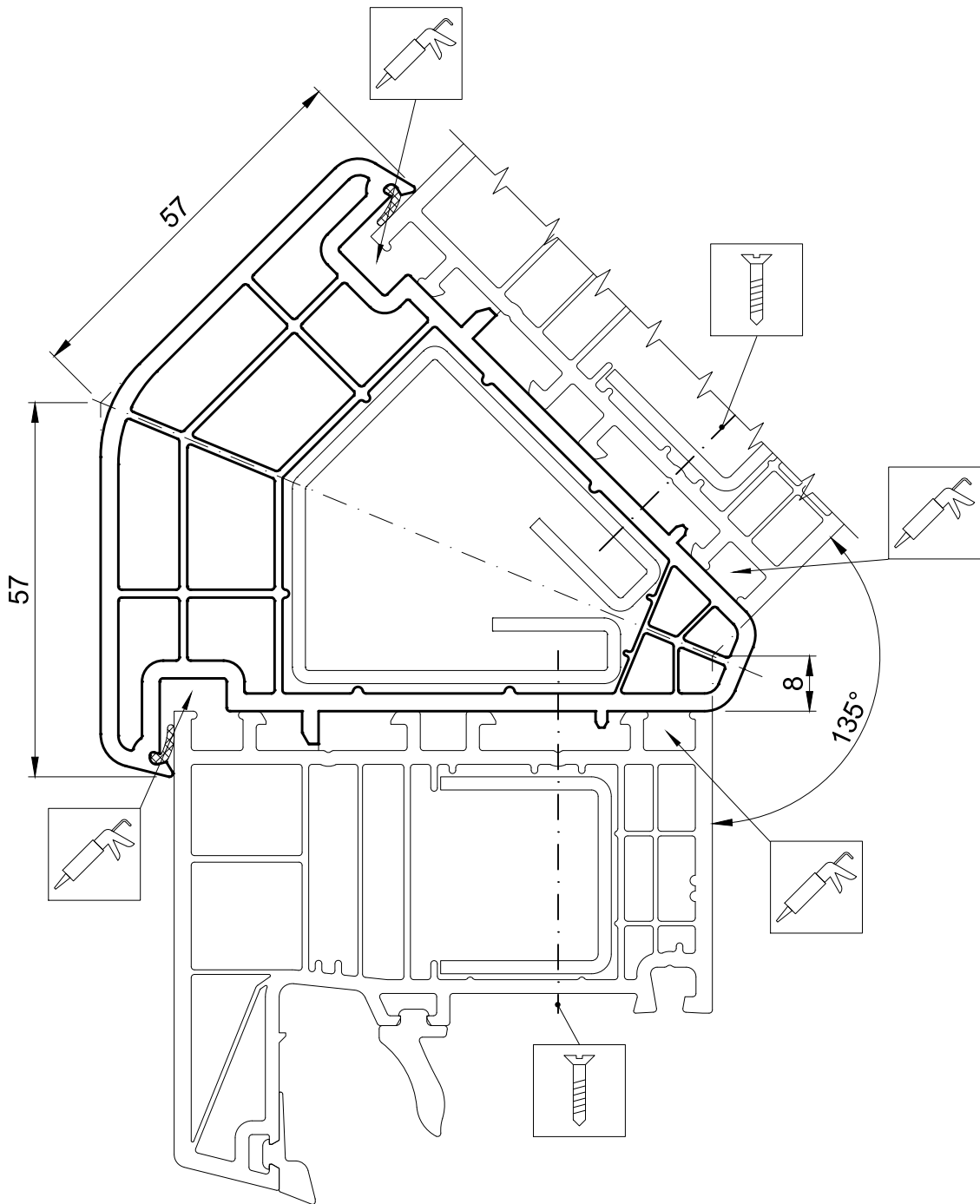

Corner connection, variable

NP8160, NP8150

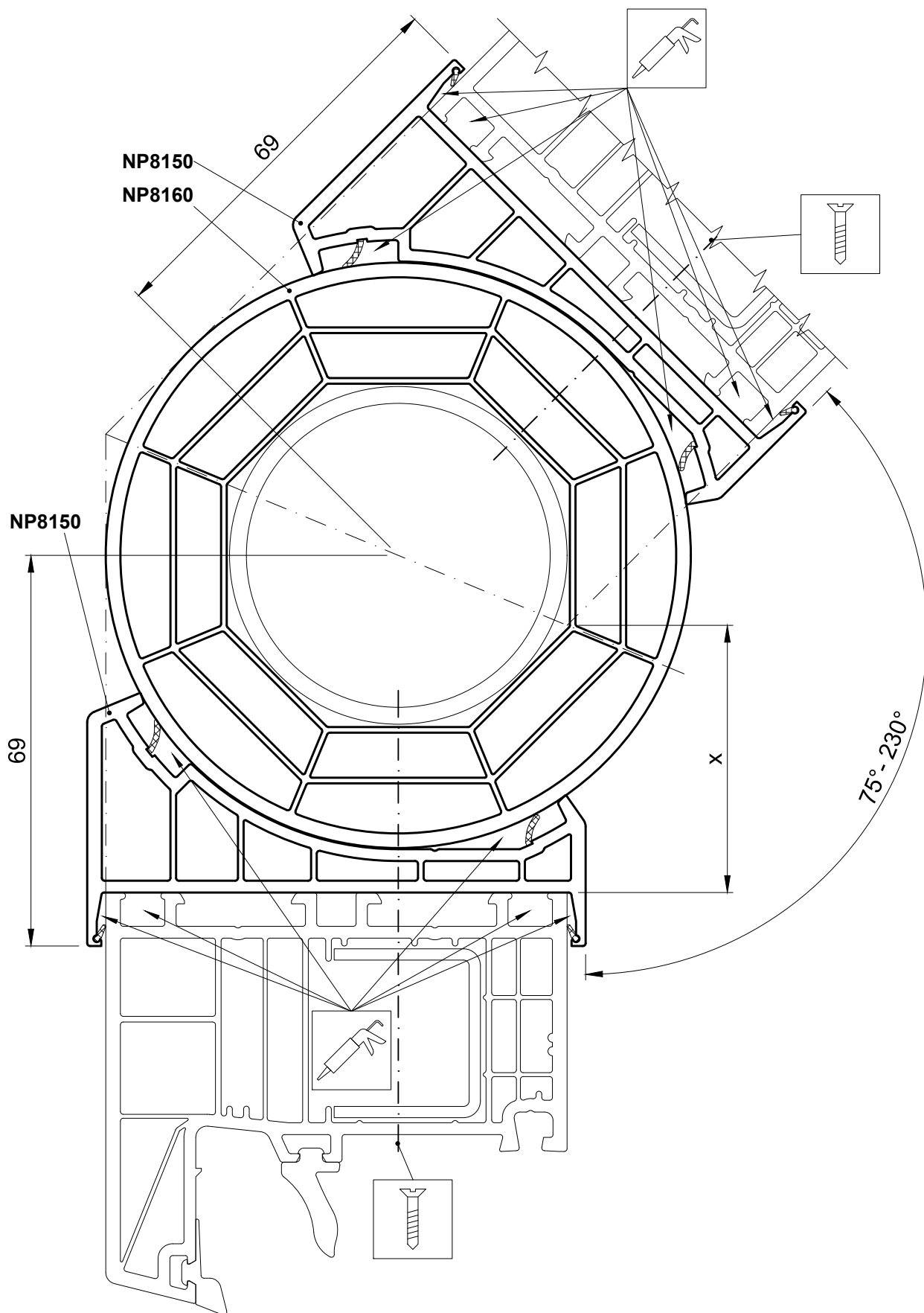

Attachment frame

**406271**

Galvanised steel.  
60 x 40 x ... mm.  
Thickness according to static specifications.  
Purchase through steel trade.

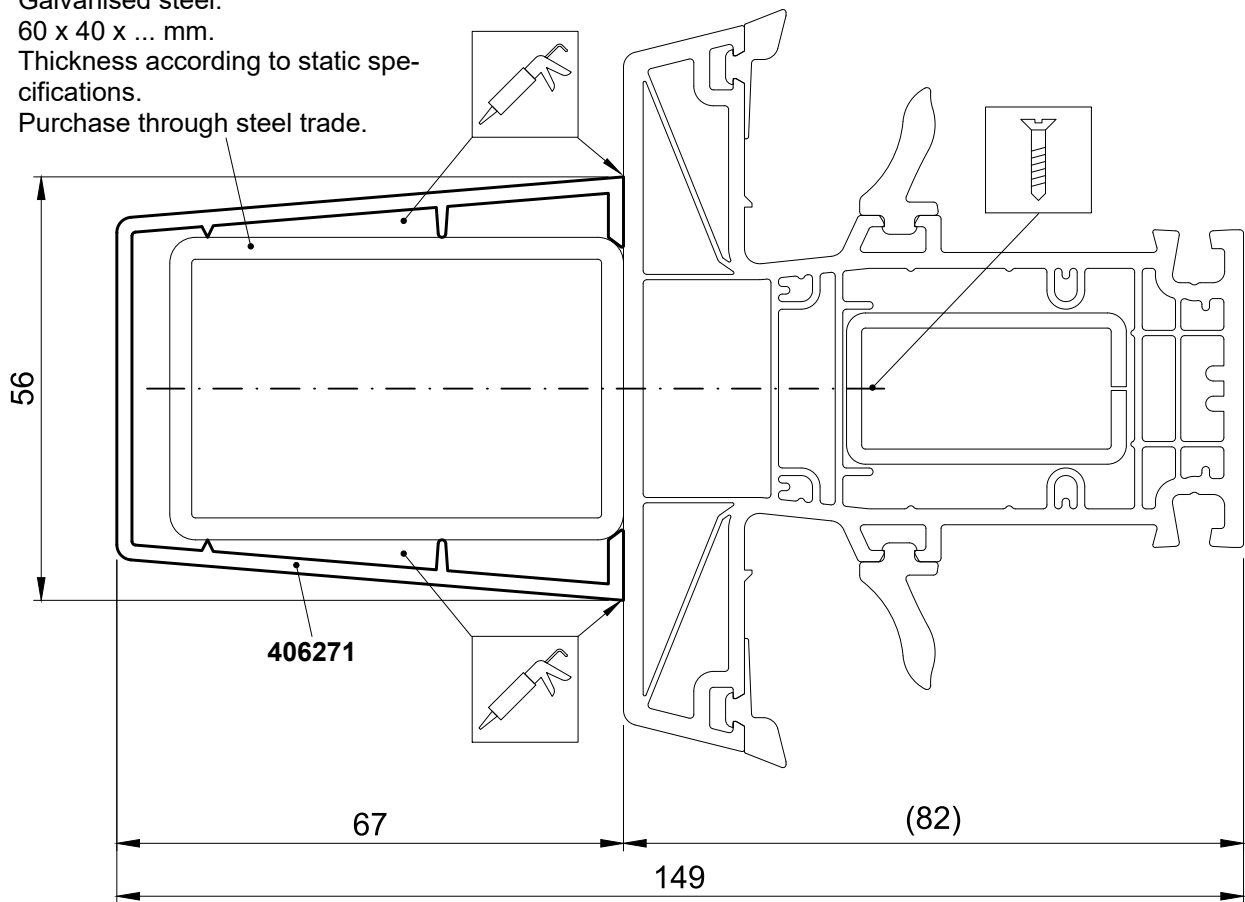

Sheathing profile

416269

Cover profile

416311

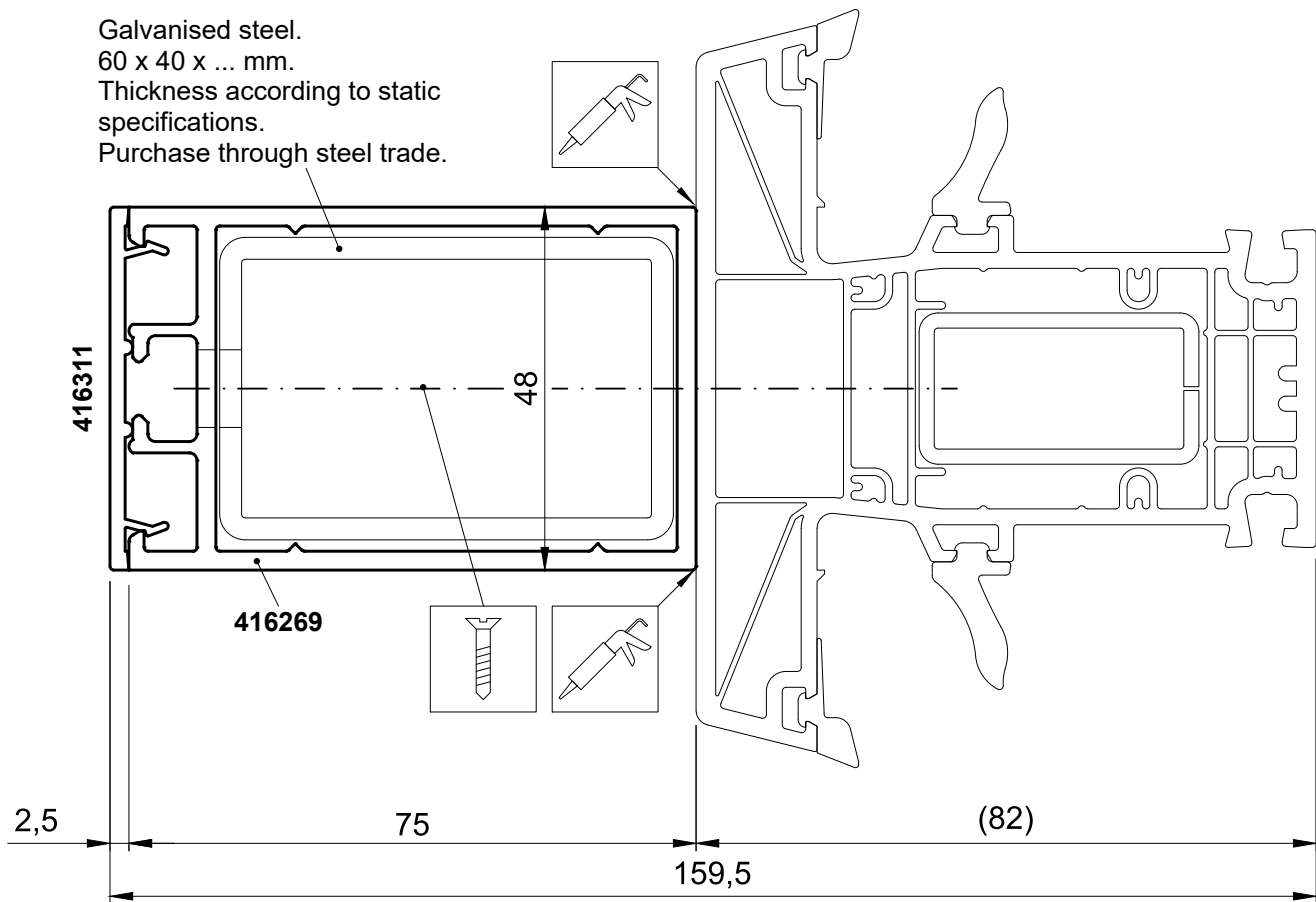

Alternative

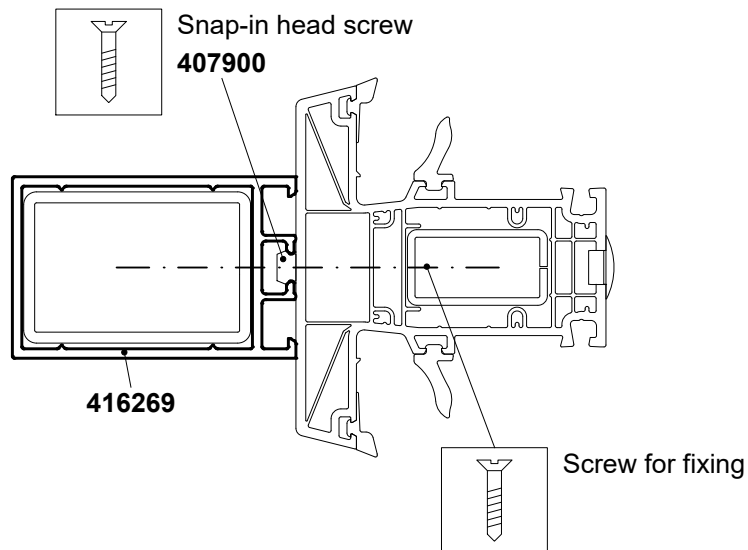

Cover profile  
**NP8180**

Cover for widenings  
**NP8270**

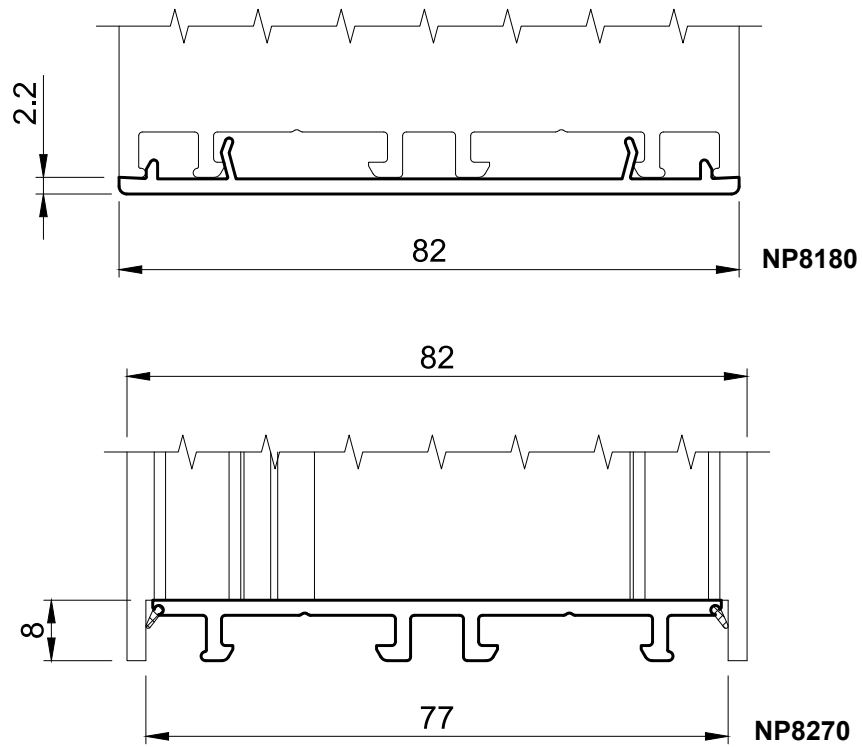

Roller shutter drain  
**RF3200, RF3220**

Roller shutter floor connection  
**RF3210**

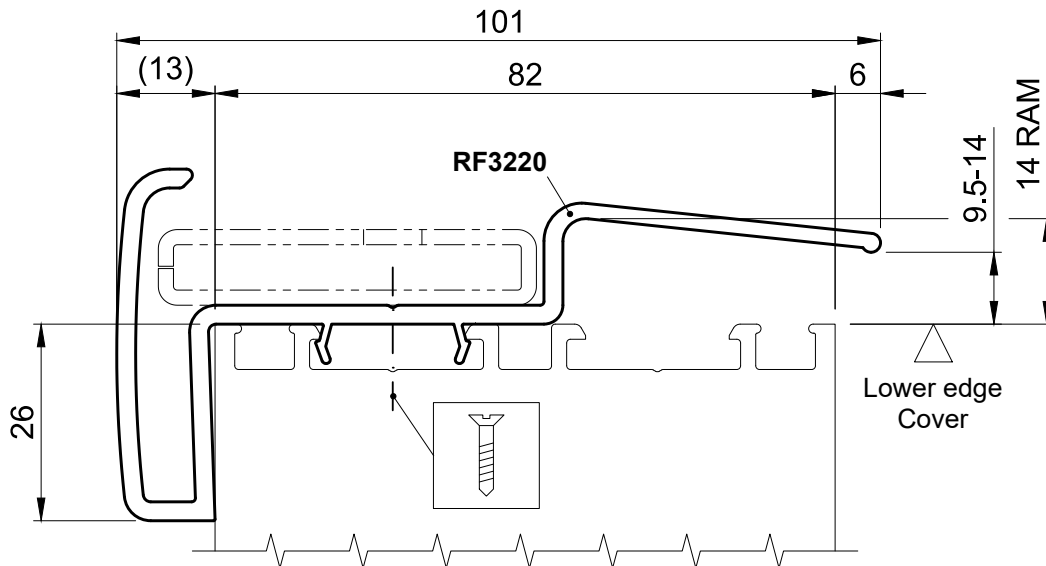
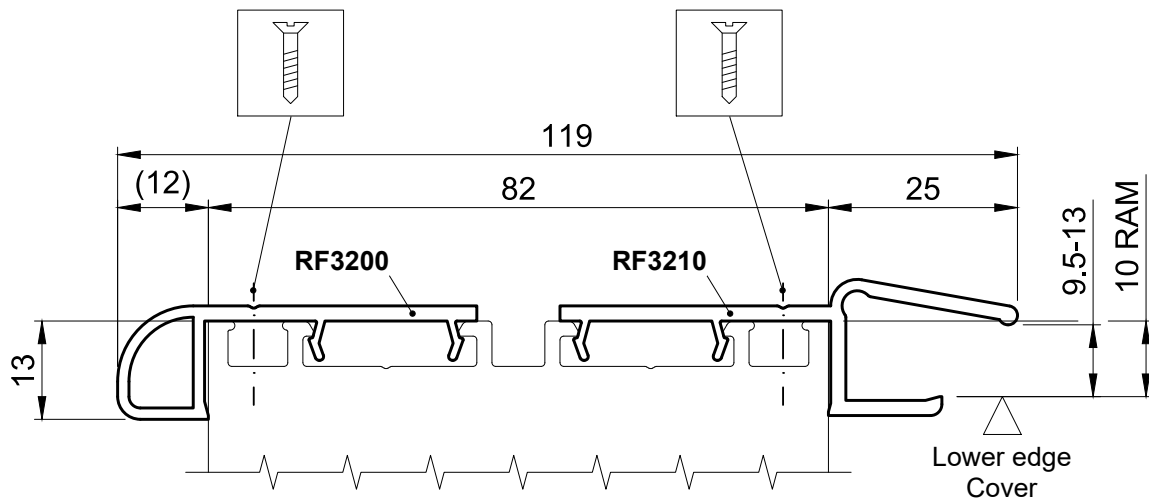

Roller shutter guides

**RF0530, 556070**

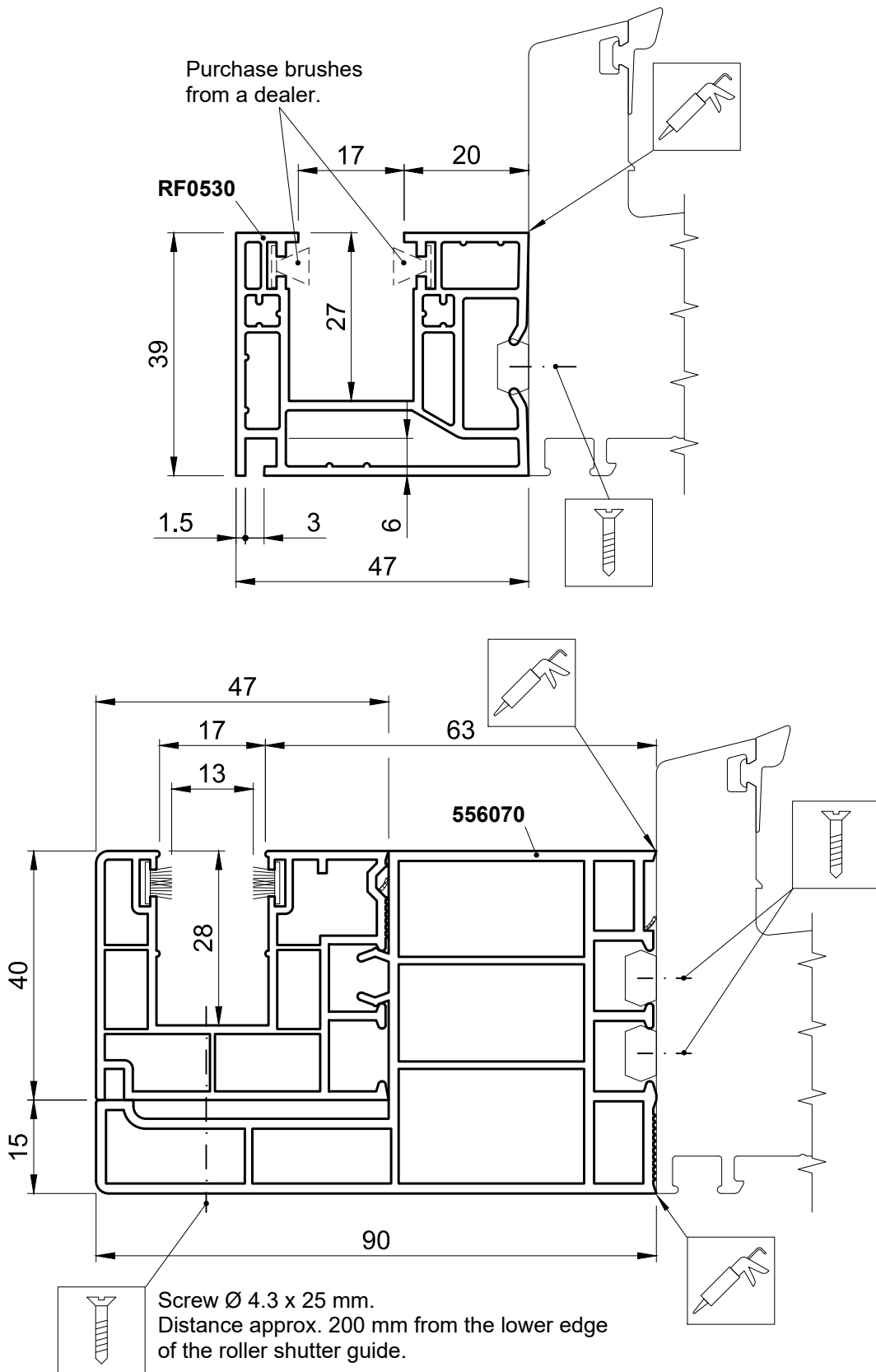

**i** INFO

Screw roller shutter rail above window sill using adapter profile.

Roller shutter guide

416086

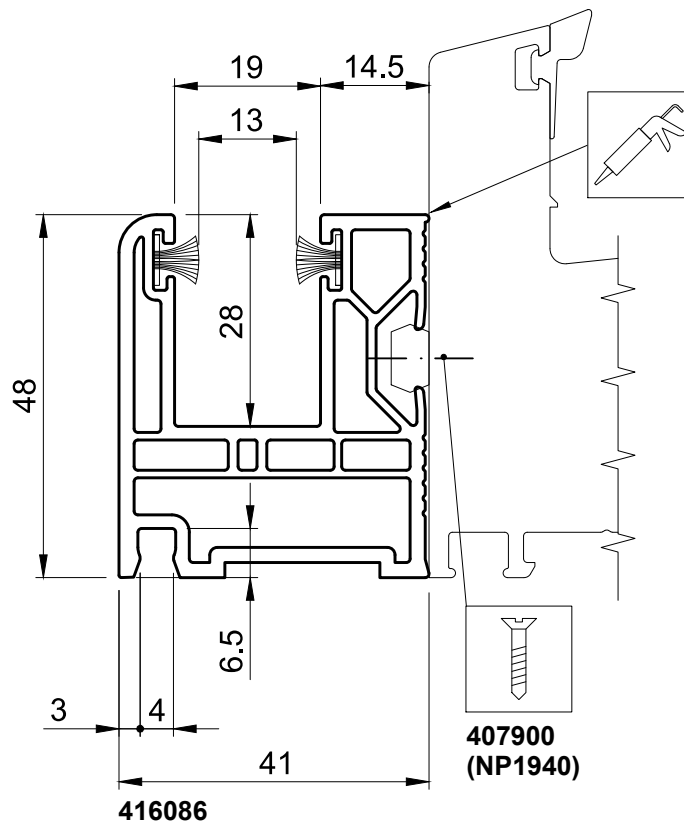

Roller shutter guide

416096

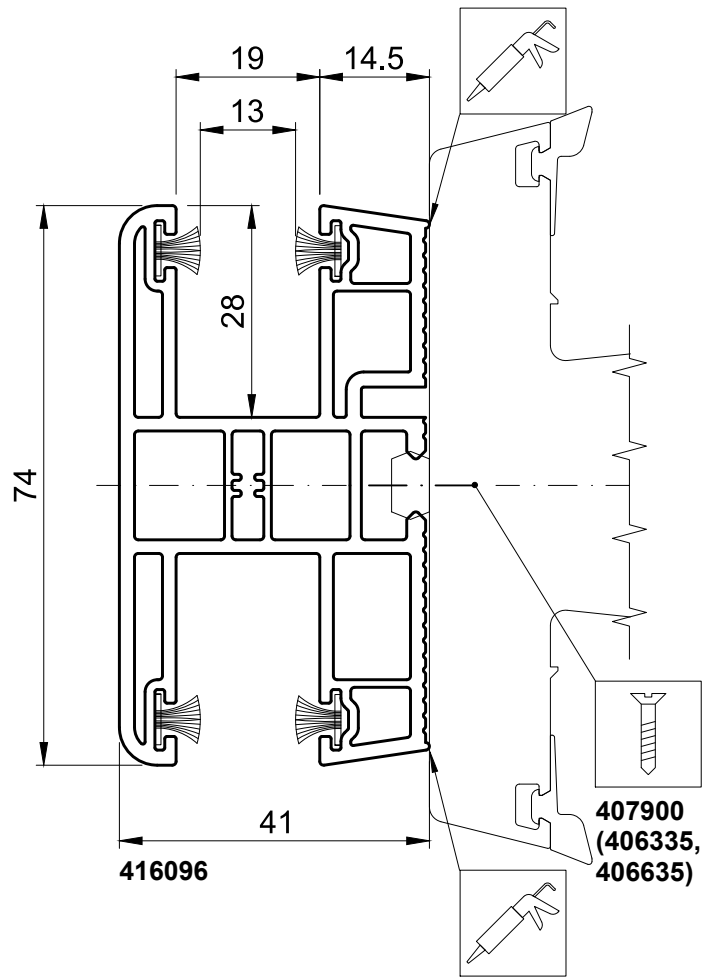

Aluminium clip facing shell Fixed glazing frame

VA9022

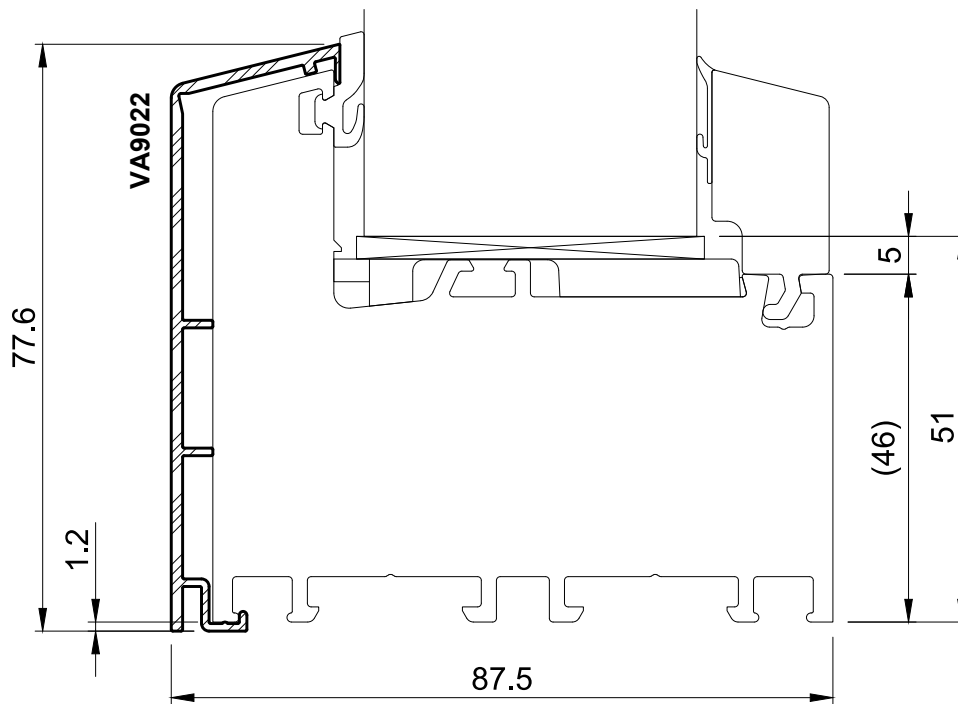
**i** INFO

Application VA9022 with frames HO8020, HO8021, HO9020, HO9021 and old building frames HO9100, HO9110.

Aluminium clip facing shell Fixed glazing frame

**VA9022**

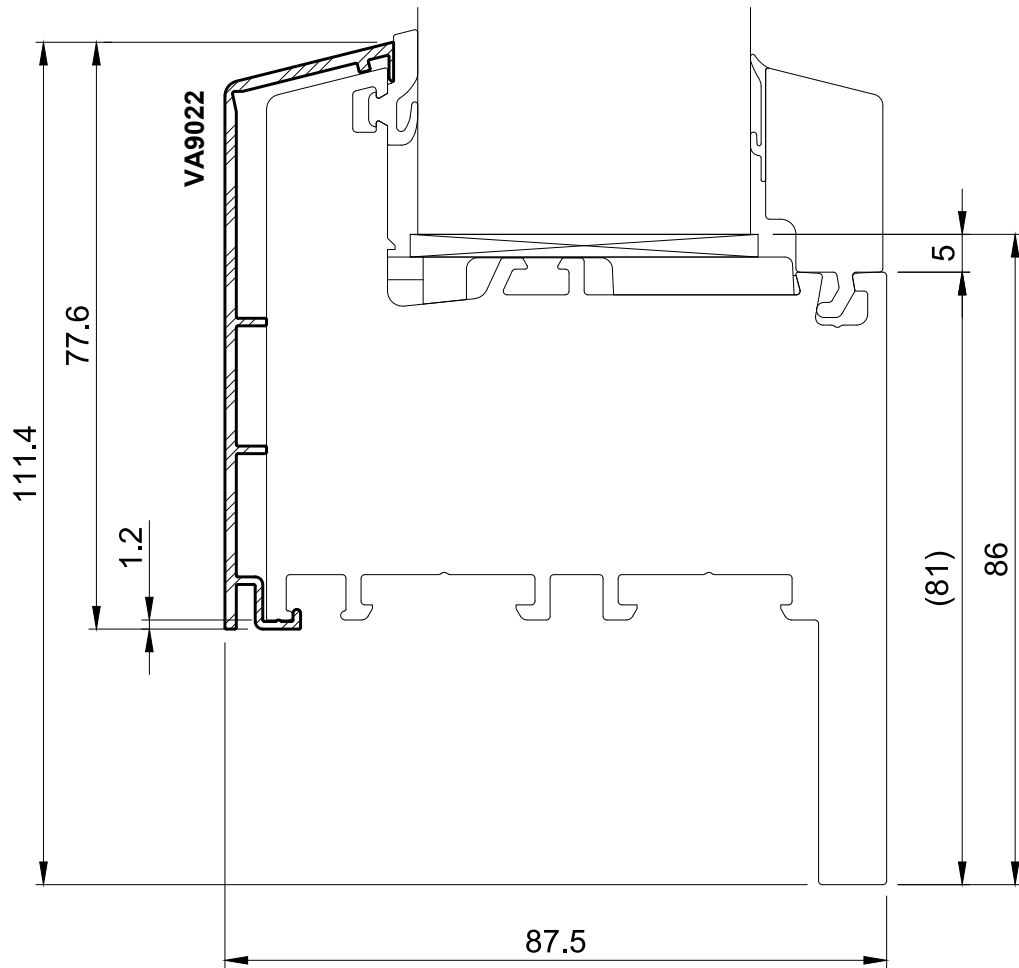

**i** INFO

Application VA9022 with frames HO8020, HO8021, HO9020, HO9021 and old building frames HO9100, HO9110.

Aluminium clip facing shell Fixed glazing frame

VA9032

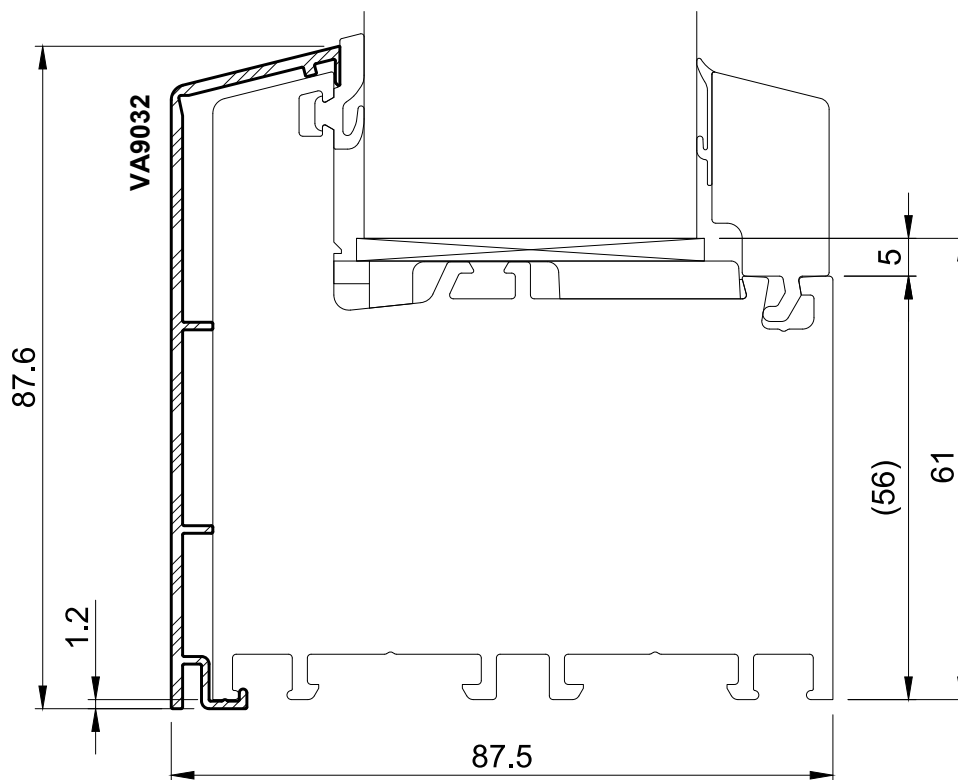

**i** INFO

Application VA9032 for frames HO8030, HO9030.

Aluminium clip facing shells Sash - Frame

VA8523, VA9022

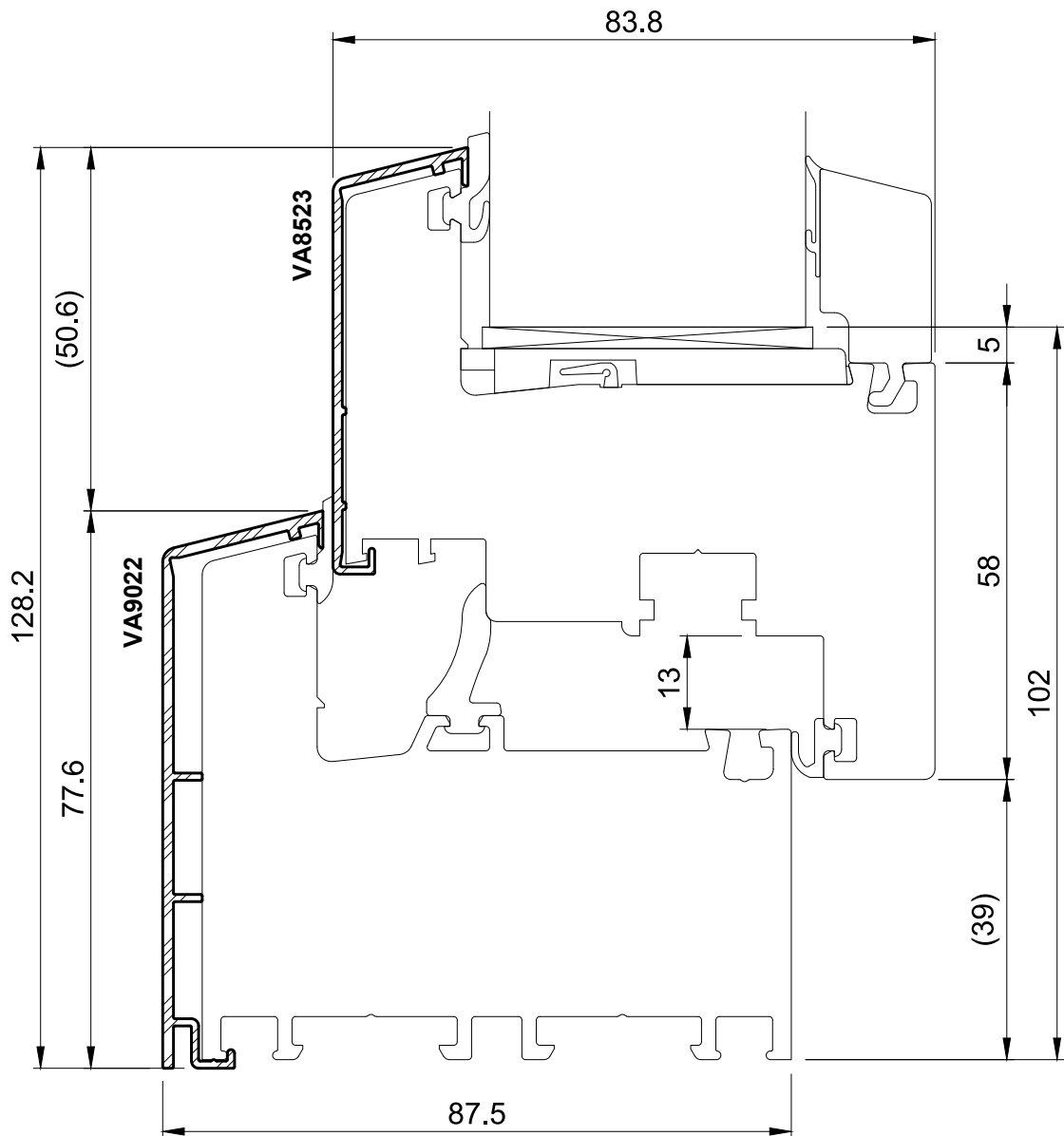

**i** INFO

Application VA8523 with sashes HO8520, HO8521.

Application VA9022 with frames HO8020, HO8021, HO9020, HO9021 and old building frames HO9100, HO9110.

Aluminium clip facing shells Sash - Frame

VA8523, VA9022

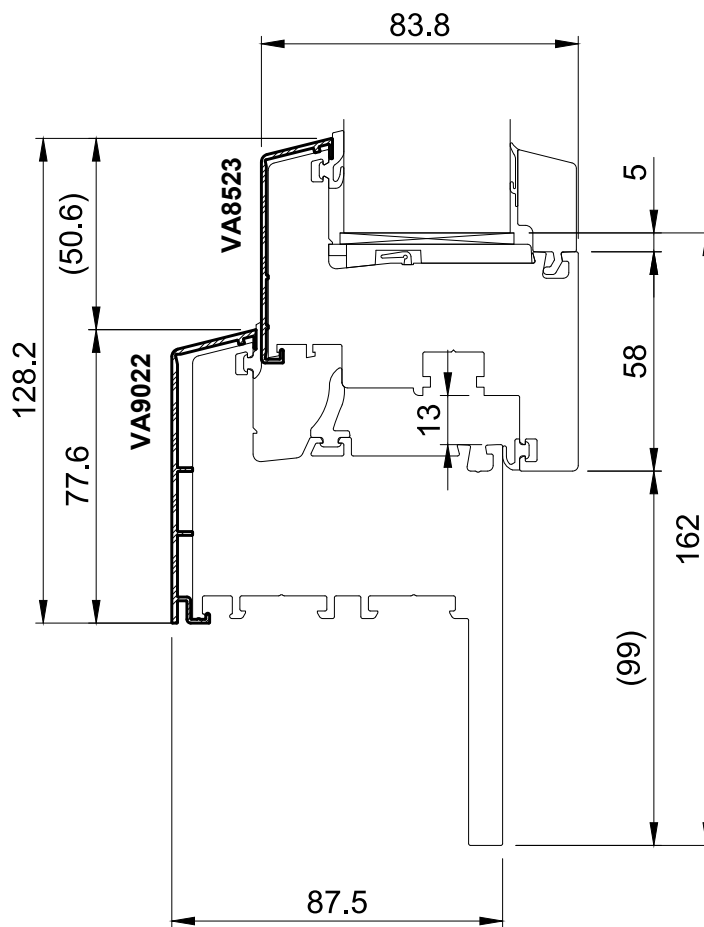

**i** INFO

Application VA8523 with sashes HO8520, HO8521.

Application VA9022 with frames HO8020, HO8021, HO9020, HO9021 and old building frames HO9100, HO9110.

Aluminium clip facing shells Sash - Frame

VA8523, VA9032

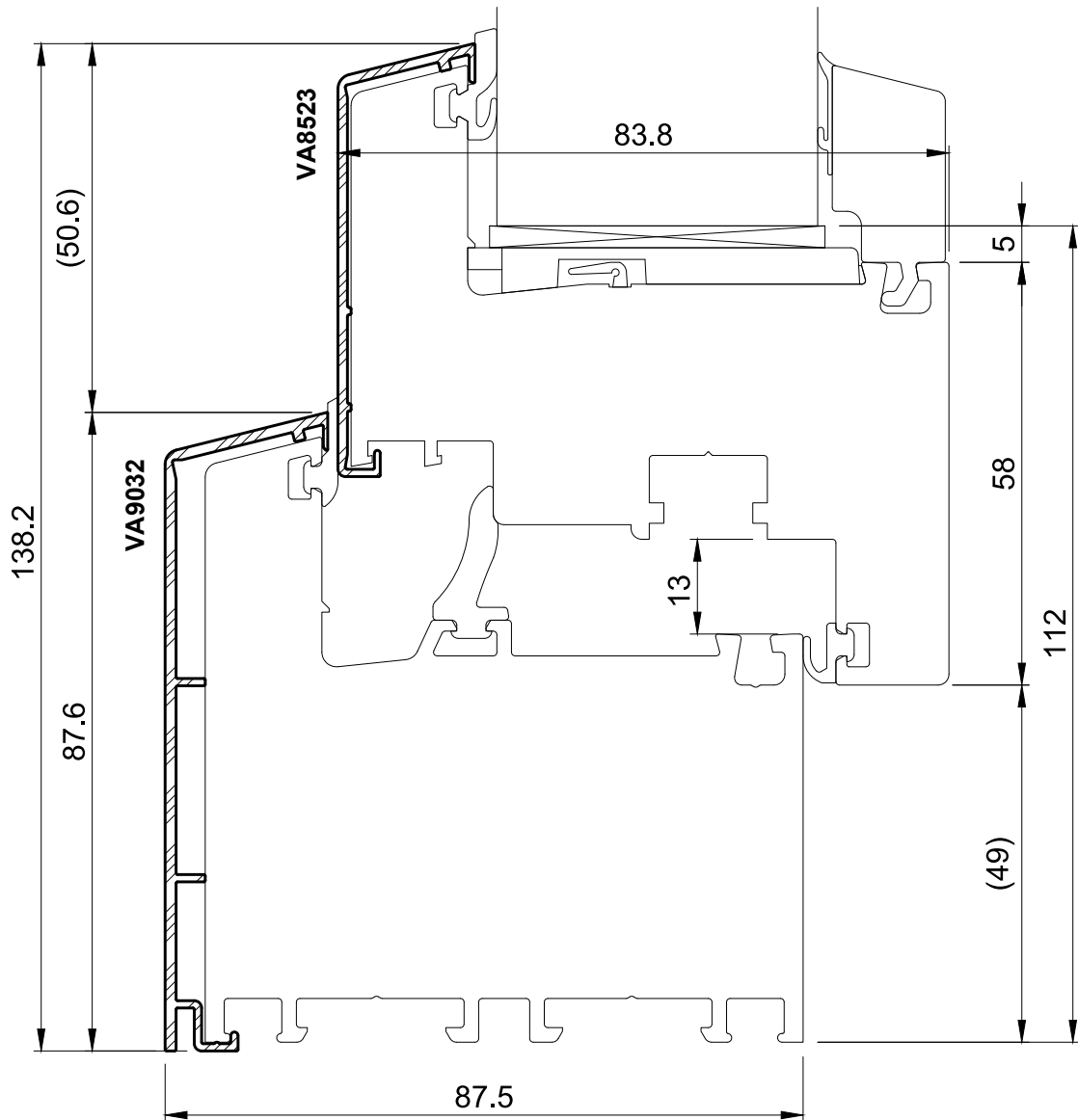

**i** INFO

Application VA8523 with sashes HO8520, HO8521.

Application VA9032 for frames HO8030, HO9030.

Aluminium clip facing shells Sash - Frame

VA8532, VA9022

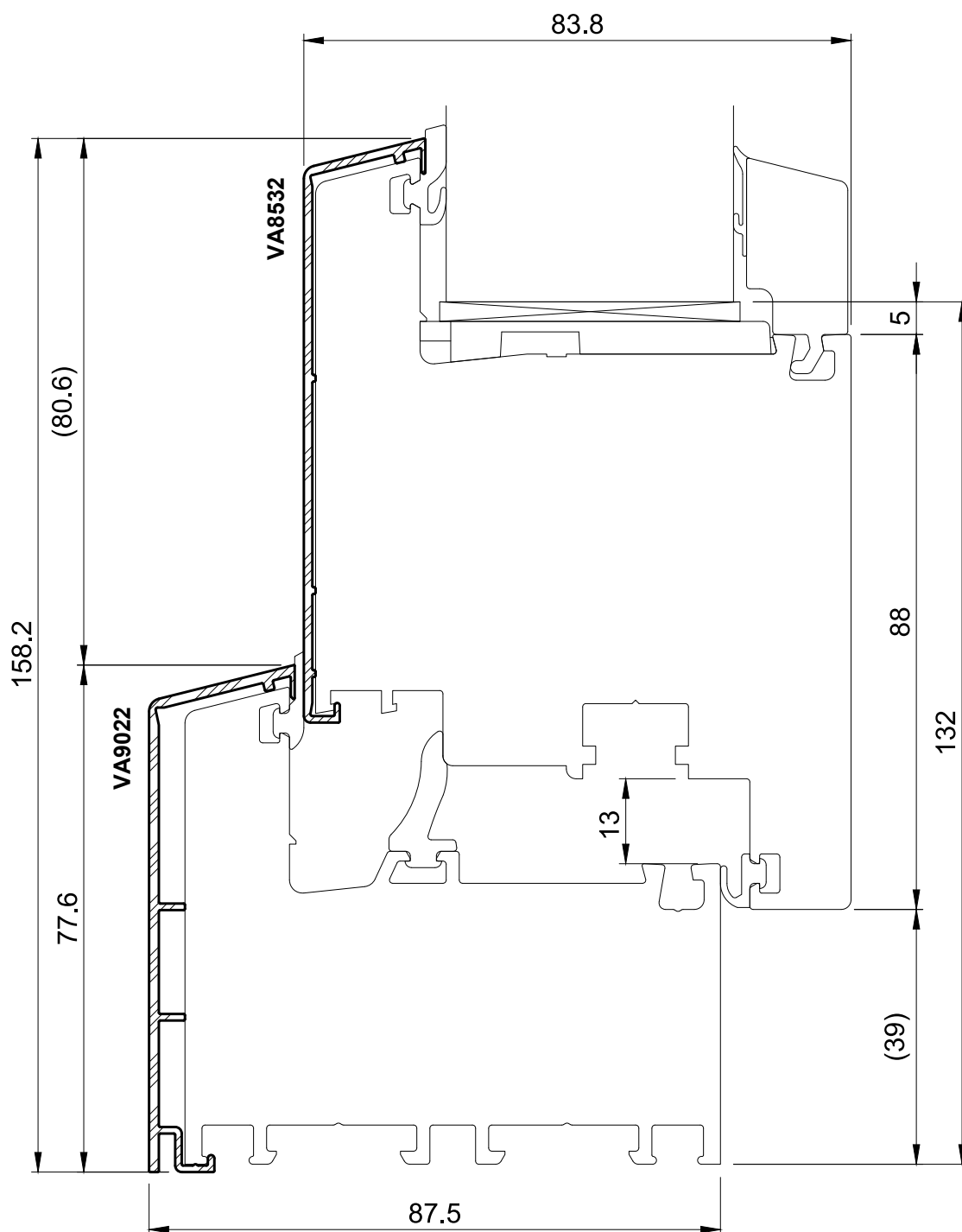

**i** INFO

Application VA8532 for sash HO8530.

Application VA9022 with frames HO8020, HO8021, HO9020, HO9021 and old building frames HO9100, HO9110.

Aluminium clip facing shells Sash - Frame

**VA8532, VA9022**

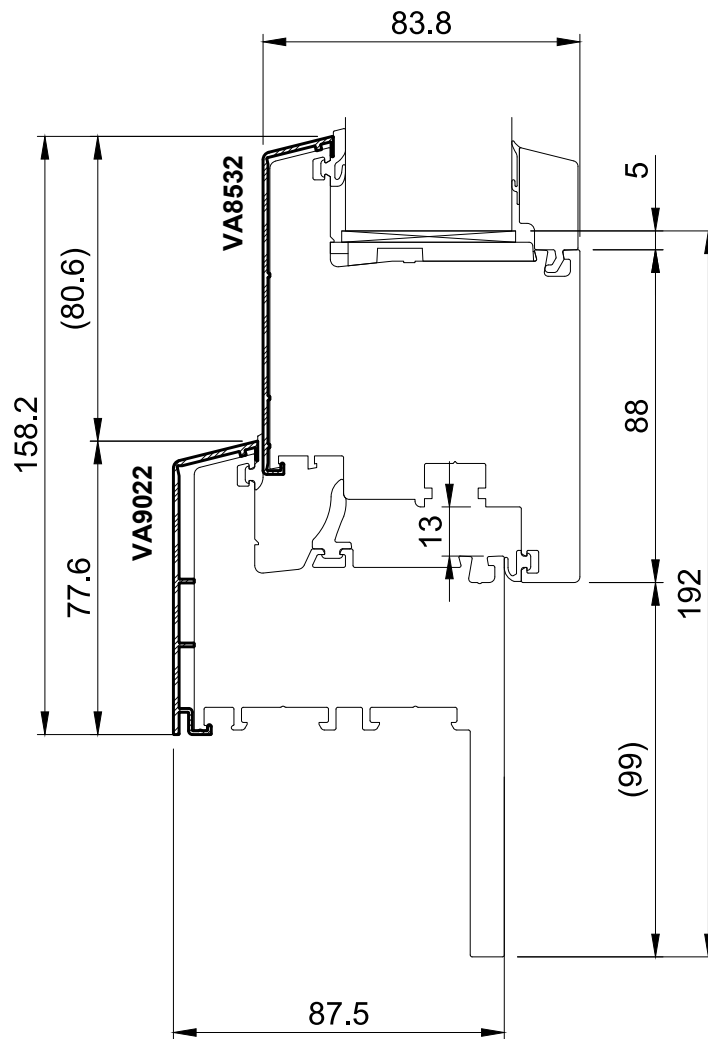

**i** INFO

Application VA8532 for sash HO8530.

Application VA9022 with frames HO8020, HO8021, HO9020, HO9021 and old building frames HO9100, HO9110.

Aluminium clip facing shells Sash - Frame

VA8532, VA9032

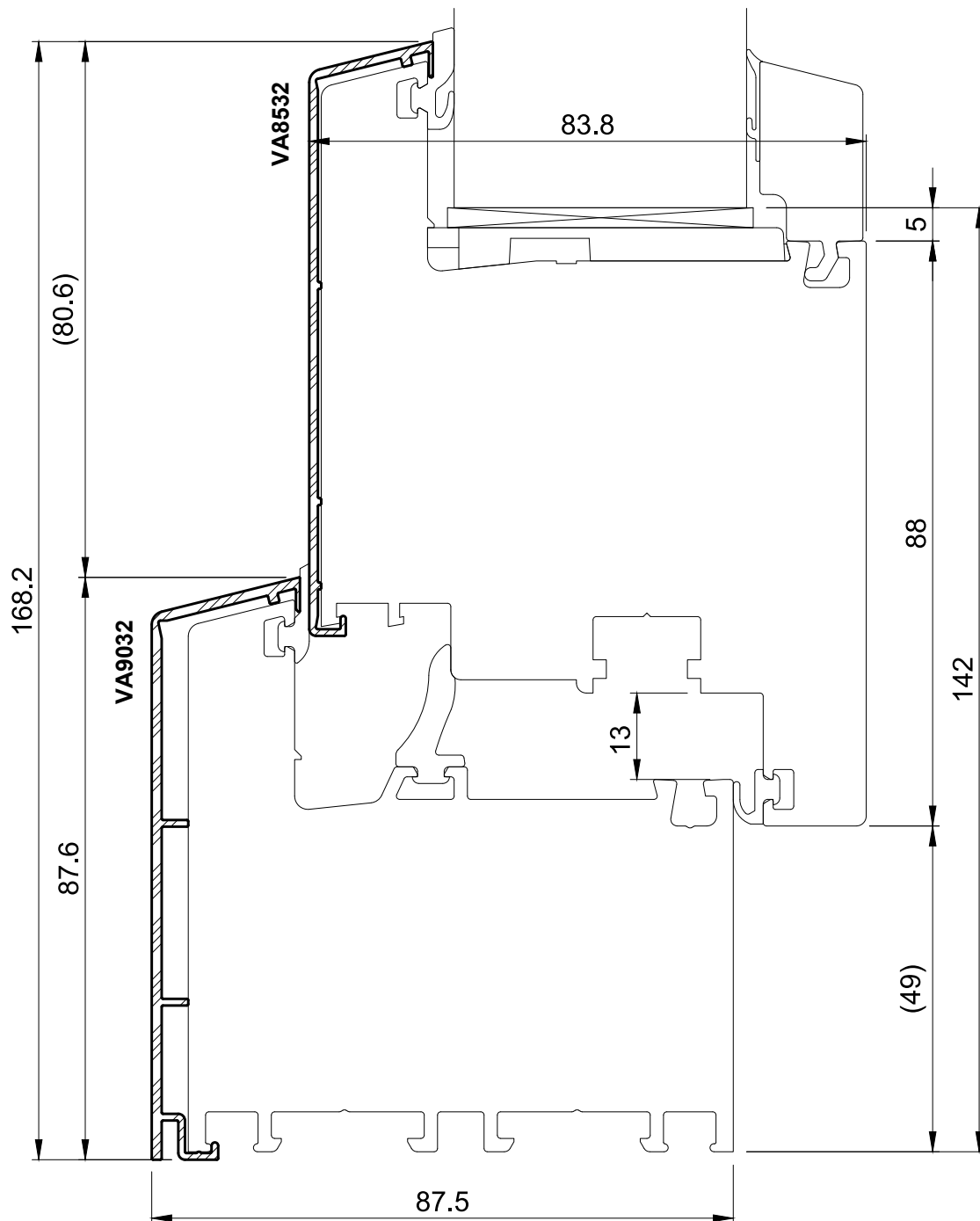

**i** INFO

Application VA8532 for sash HO8530.

Application VA9032 for frames HO9030, HO8030.

Aluminium clip facing shell Glazing bar

**VA9322**

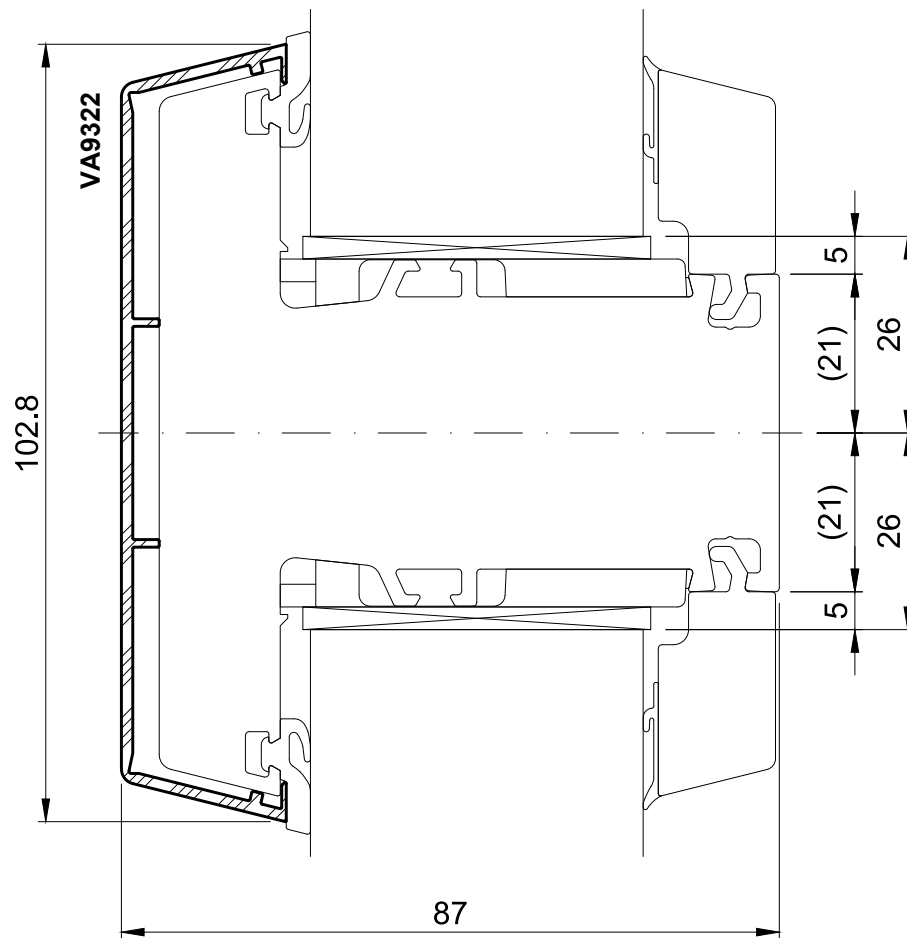

**i** INFO

Application VA9322 with fixed mullions HO8310, HO8320, HO9310, HO9320.

For application as fixed mullion in frame.

Aluminium clip facing shell Glazing bar

VA9342

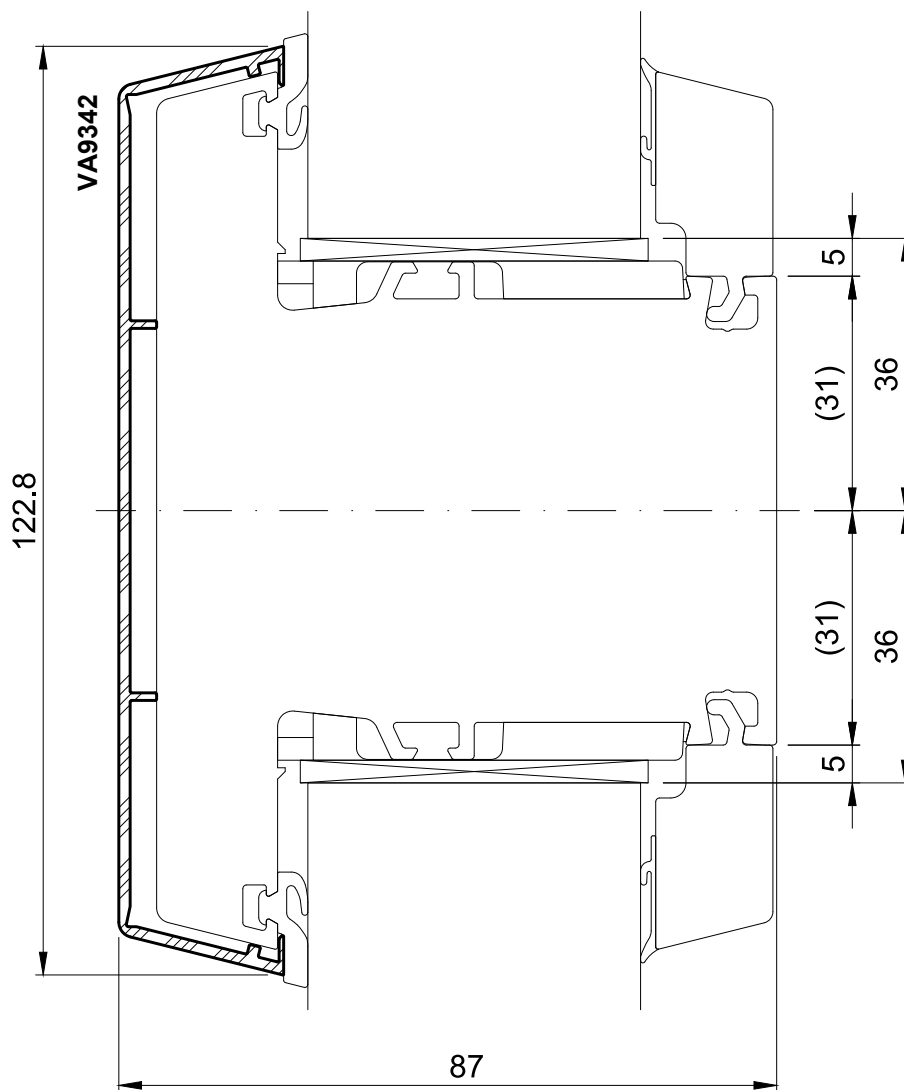

**i** INFO

Application VA9342 with fixed mullions HO9330, HO9340.

For application as fixed mullion in frame.

Aluminium clip facing shell Glazing bar

**VA8302**

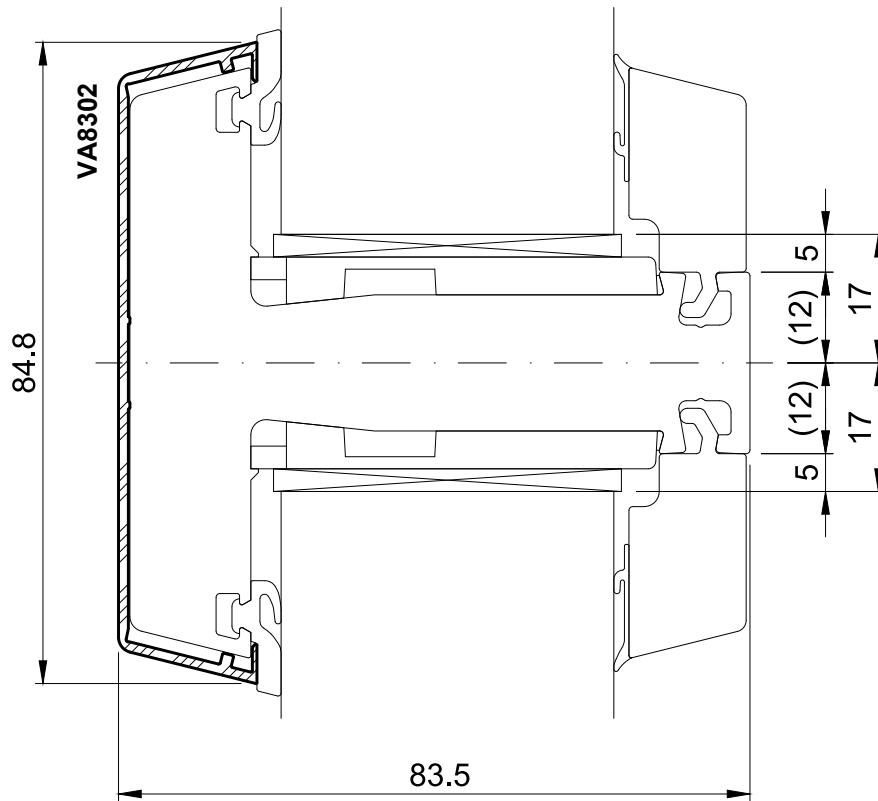

**i** INFO

Application VA8302 for glazing bar HO8300.

For application as glazing bar in sash.

Aluminium clip facing shells Sash - Fixed mullion

VA8523, VA9322

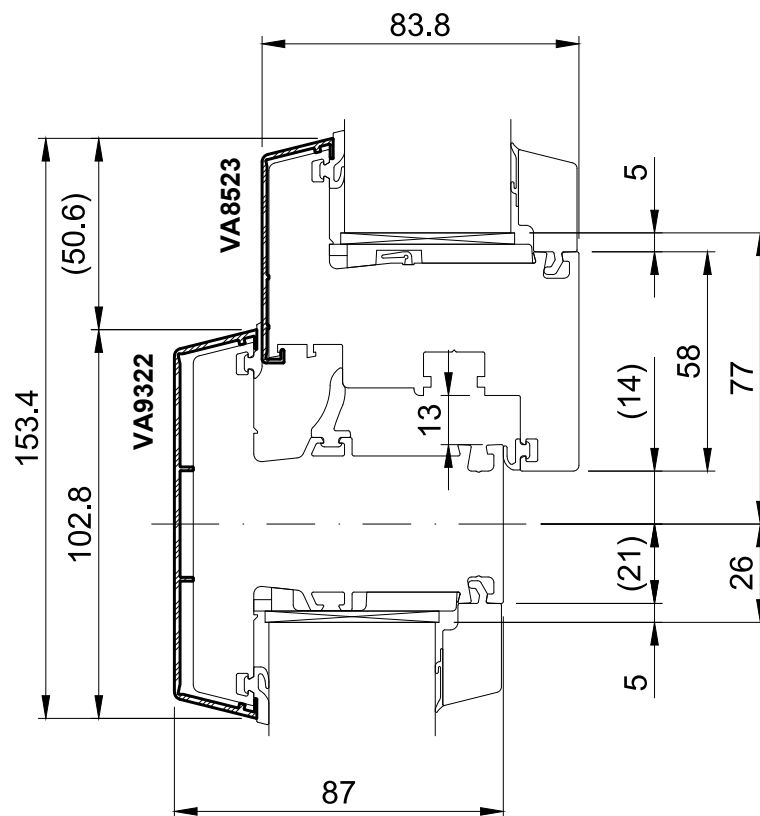
**i** INFO

Application VA8523 with sashes HO8520, HO8521.

Application VA9322 with fixed mullions HO8310, HO8320, HO9310, HO9320.

For application as fixed mullion in frame.

Aluminium clip facing shells Sash - Fixed mullion

**VA8523, VA9342**

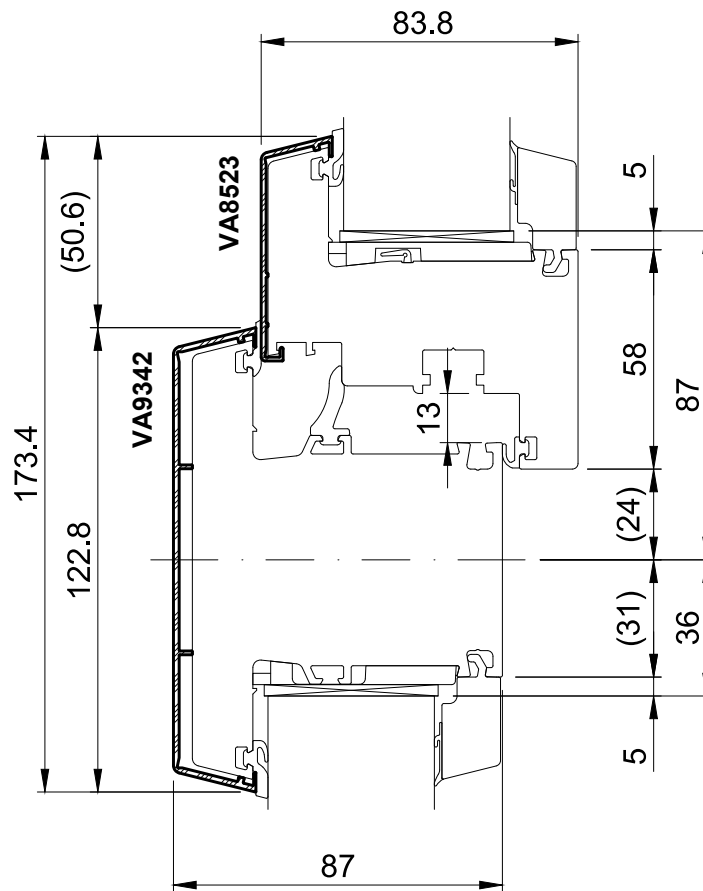

**i** INFO

Application VA8523 with sashes HO8520, HO8521.

Application VA9342 with fixed mullions HO9330, HO9340.

For application as fixed mullion in frame.

Aluminium clip facing shells Sash - Fixed mullion

VA8532, VA9322

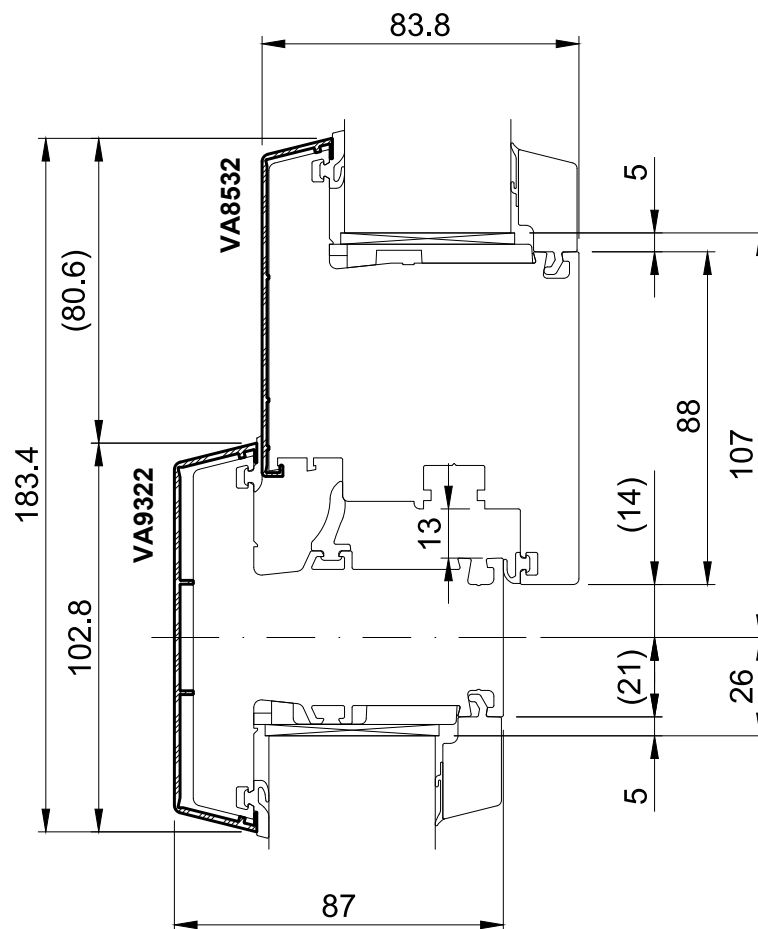
**i** INFO

Application VA8532 for sash HO8530.

Application VA9322 with fixed mullions HO8310, HO8320, HO9310, HO9320.

For application as fixed mullion in frame.

Aluminium clip facing shells Sash - Fixed mullion

VA8532, VA9342

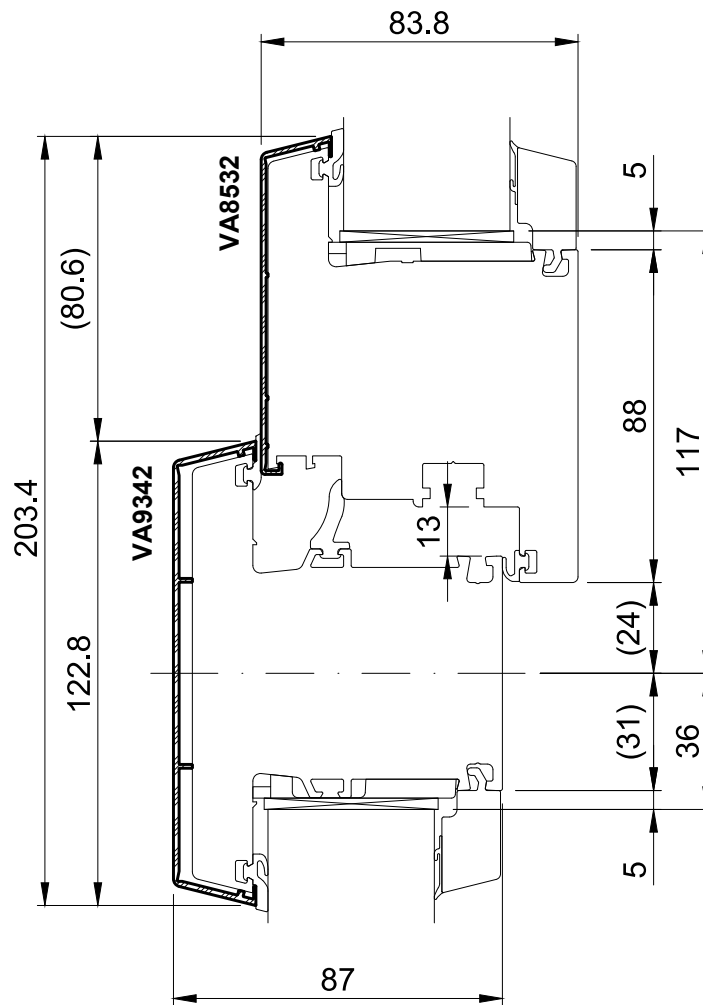

**i** INFO

Application VA8532 for sash HO8530.

Application VA9342 with fixed mullions HO9330, HO9340.

For application as fixed mullion in frame.



Aluminium clip facing shells Faceplate

VA8532, VA9812

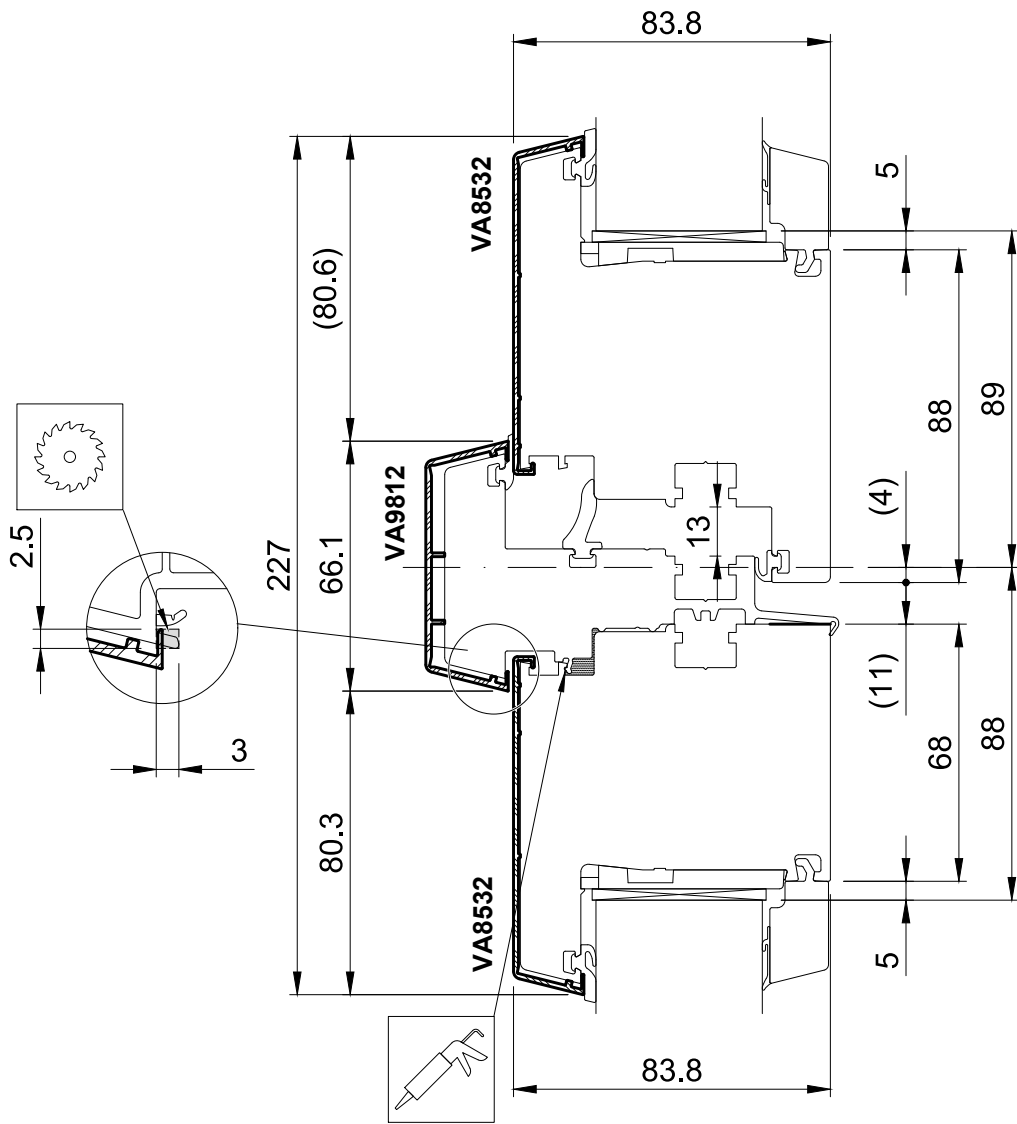

**i** INFO

Application VA8532 for sash HO8530.

Application VA9812 right-angled profile HO9810.





Aluminium clip facing shells widening

VA9022, VA8303

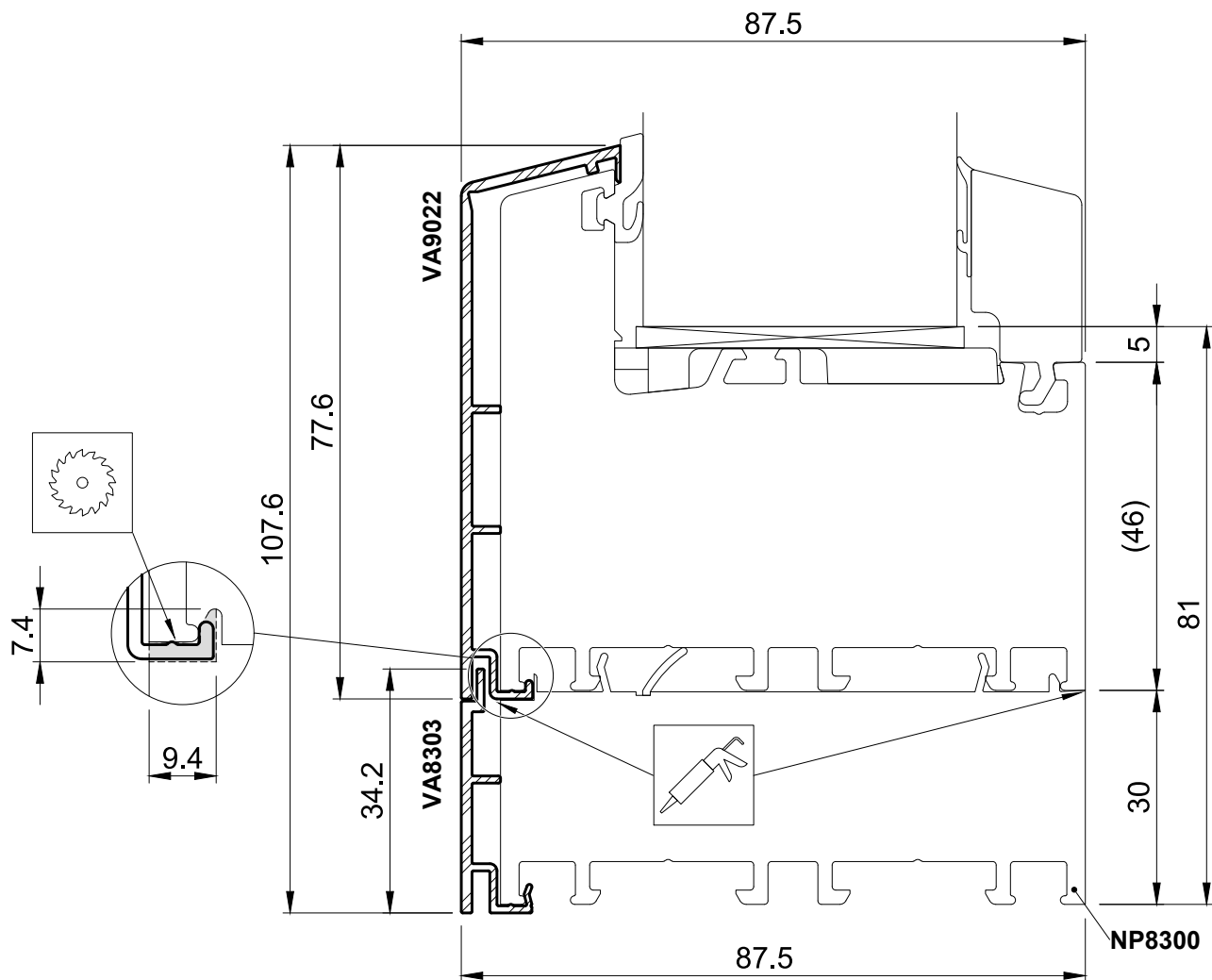

**i** INFO

Application VA8303 for widening NP8300.

Aluminium clip facing shells widening

**VA9022, VA8503**

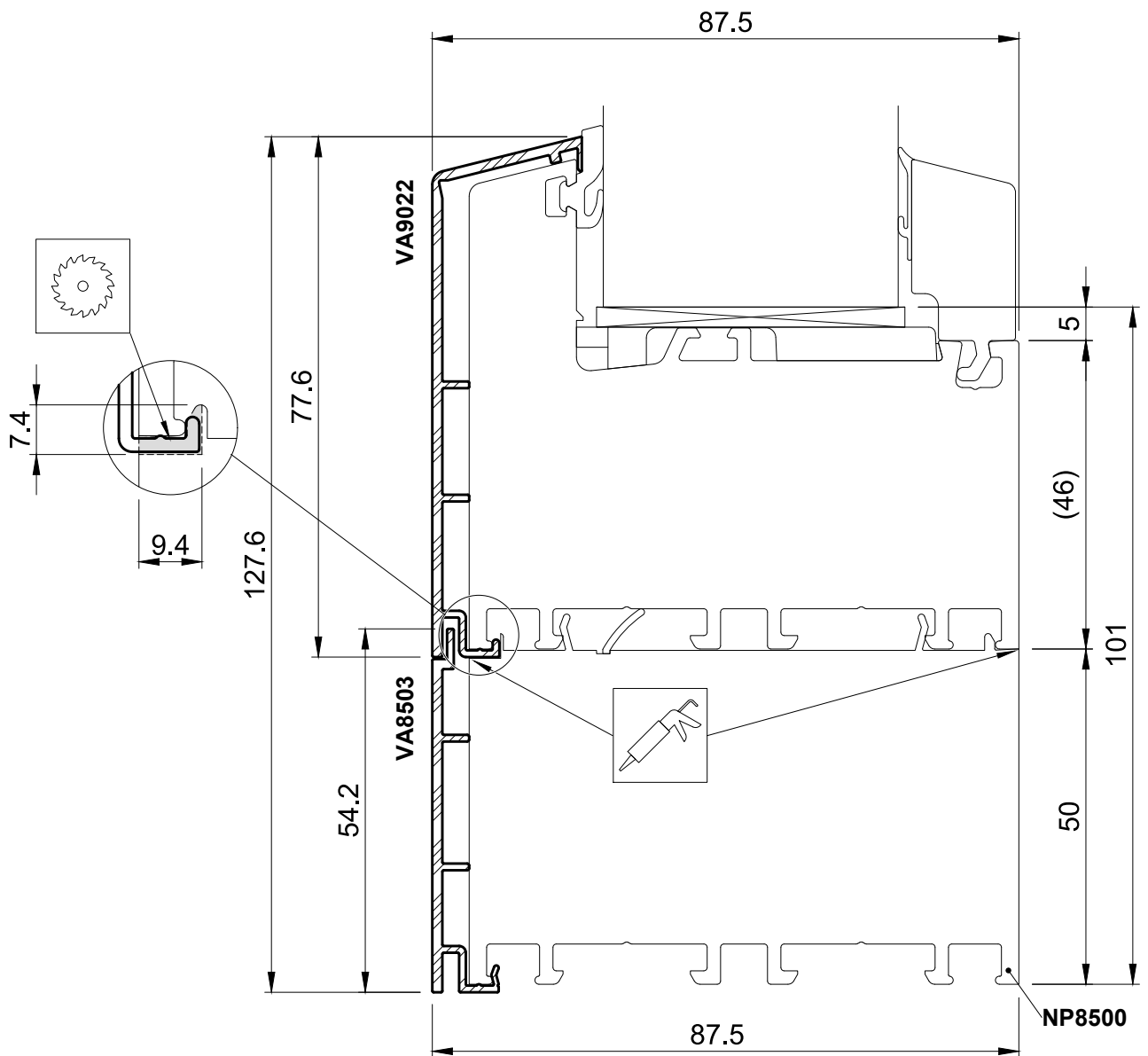

**i** INFO

Application VA8503 for widening NP8500.

Aluminium clip facing shells widening

VA9022, VA8703

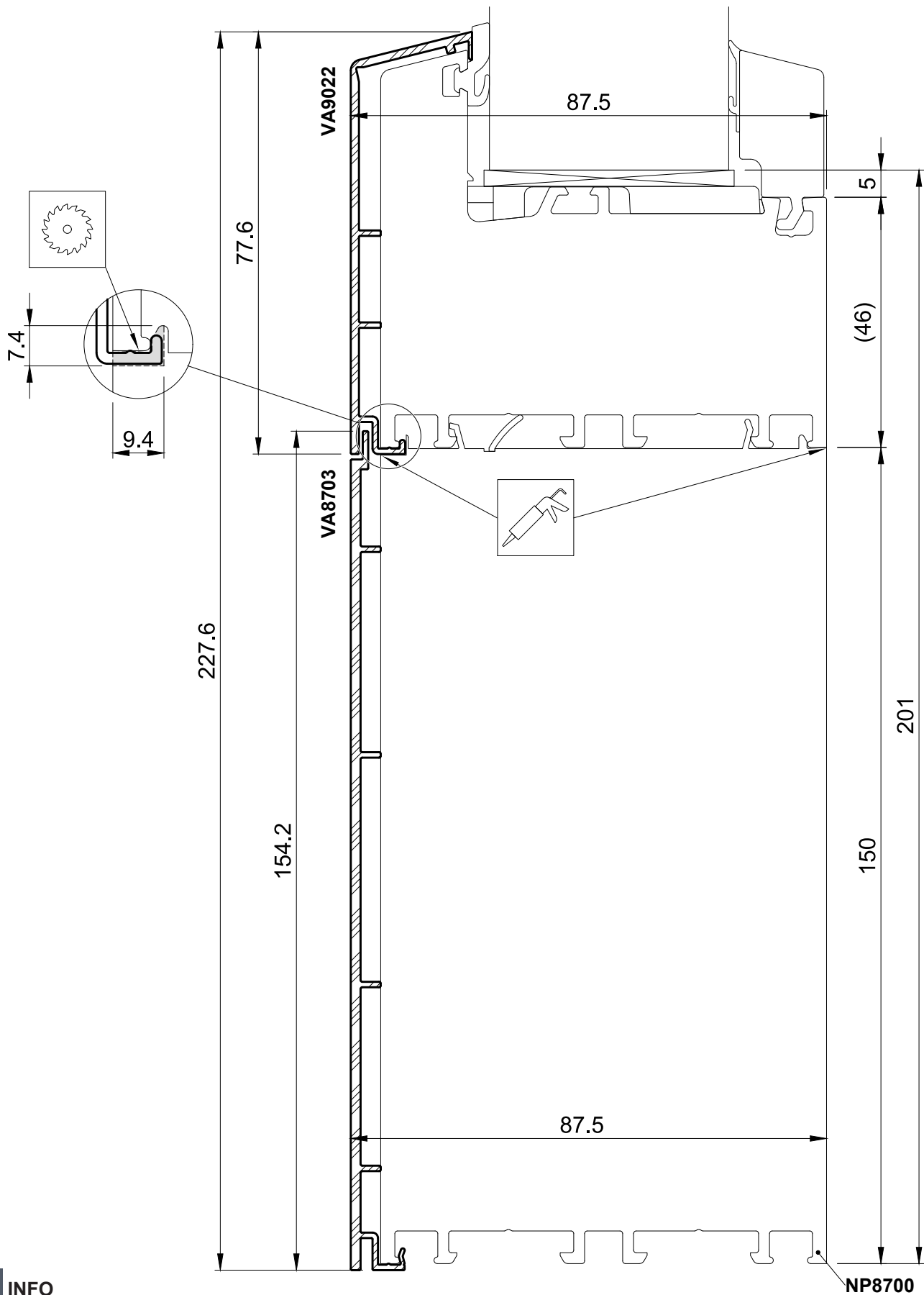

**i** INFO

Application VA8703 for widening NP8700.

Aluminium clip facing shells coupling

**VA9022, VA9410**

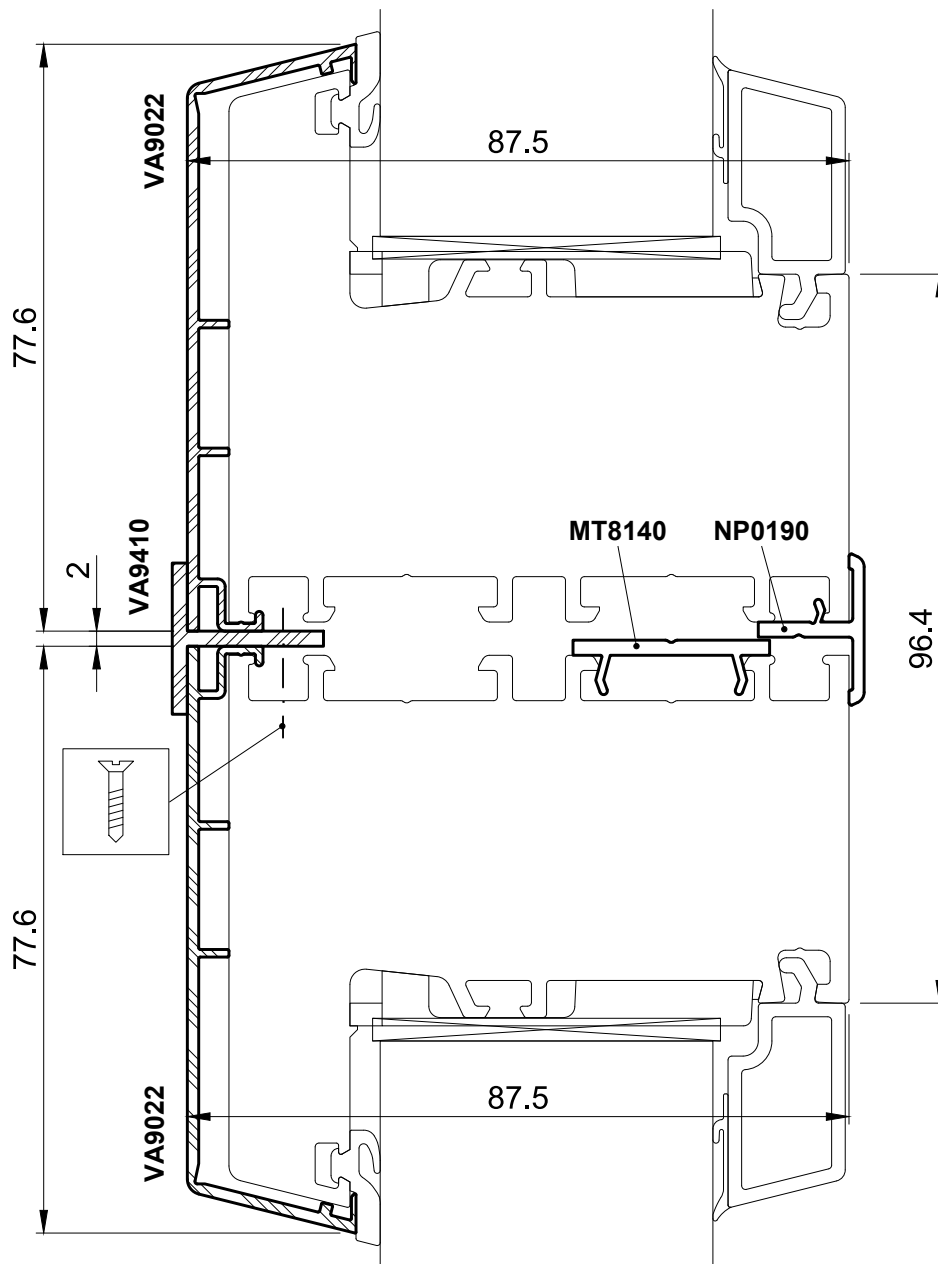

**i** INFO

Application VA9410 for coupling NP0190.

Aluminium clip facing shells coupling

VA9022, VA9400

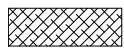
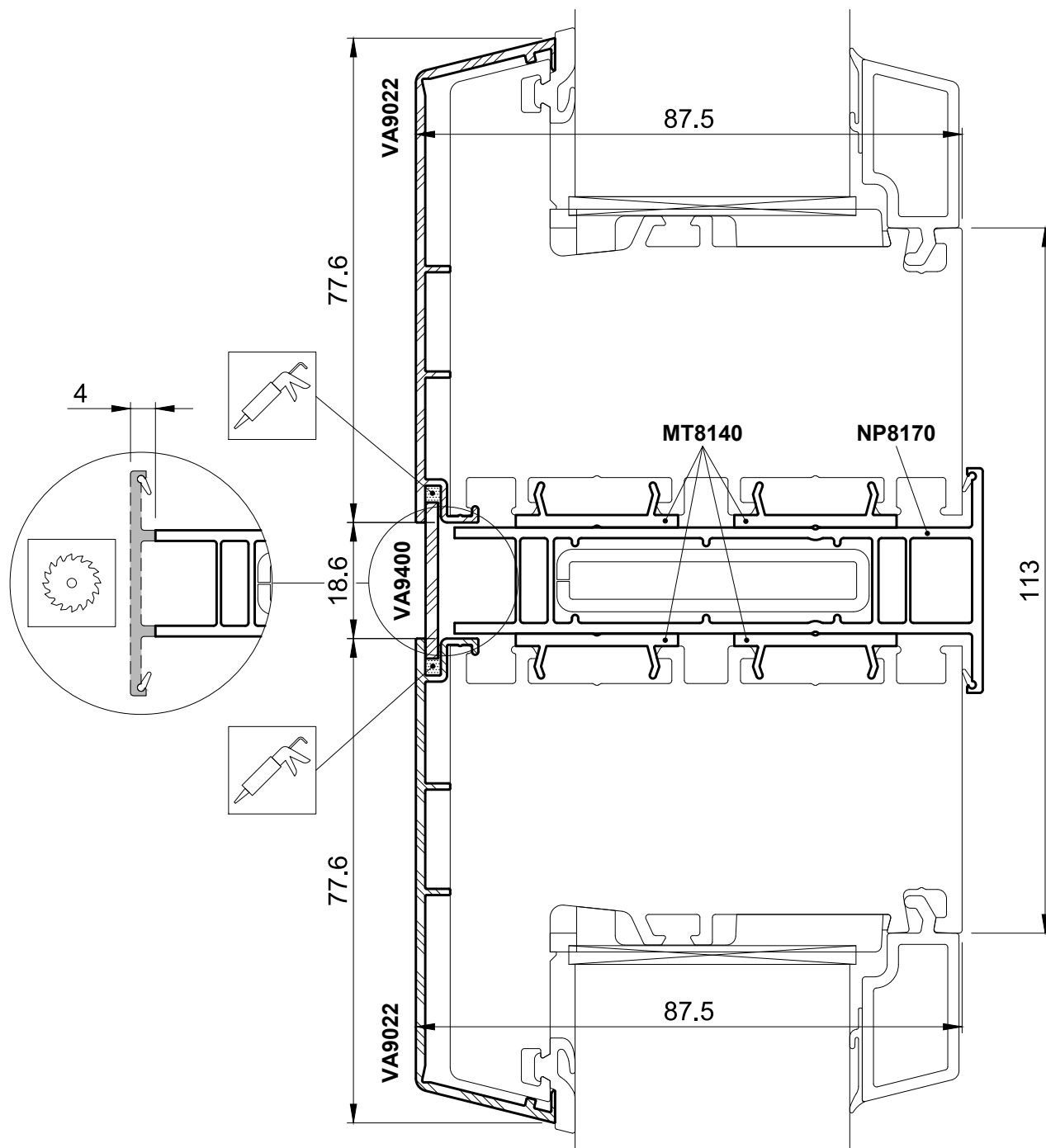

Pre-compressed sealing tape

**i** INFO

Application VA9400 for coupling NP8170.

## Chapter 5

**Window statics**

---

<b>Designation</b>	<b>Page</b>
Strengthening guidelines	1
Maximum frame sizes	2
Sash sizes	3
Wind load	98
Driving rain tightness	104

---



**Why brace?**

The bending strength of PVC-U window profiles and PVC-U door profiles is relatively low. Additional bracing profiles made of steel or aluminium must be used in many cases. In this way, elements can be built that function smoothly and permanently.

**Frames**

- ▶ Brace all frames.

Exceptions:

- White frames without pattern up to a maximum profile length of 80 cm. Condition:
  - Proper fastening of the frame to the building structure.
  - No security components
  - No installation of add-on parts, e.g. shading elements.
  - Maximum sash weight 40 kg, and/or glass weight for fixed glazing / fixed light.

**Fixed mullions and glazing bars / mullions**

- ▶ Strengthen all fixed mullions and glazing bars / mullions.

**Sashes and floating mullions / faceplates**

- ▶ Strengthen sashes and floating mullions / faceplates according to the following size diagrams.

Exceptions:

- White sashes without pattern up to 60 cm x 80 cm (width x height).

### Maximum frame sizes, white and pattern

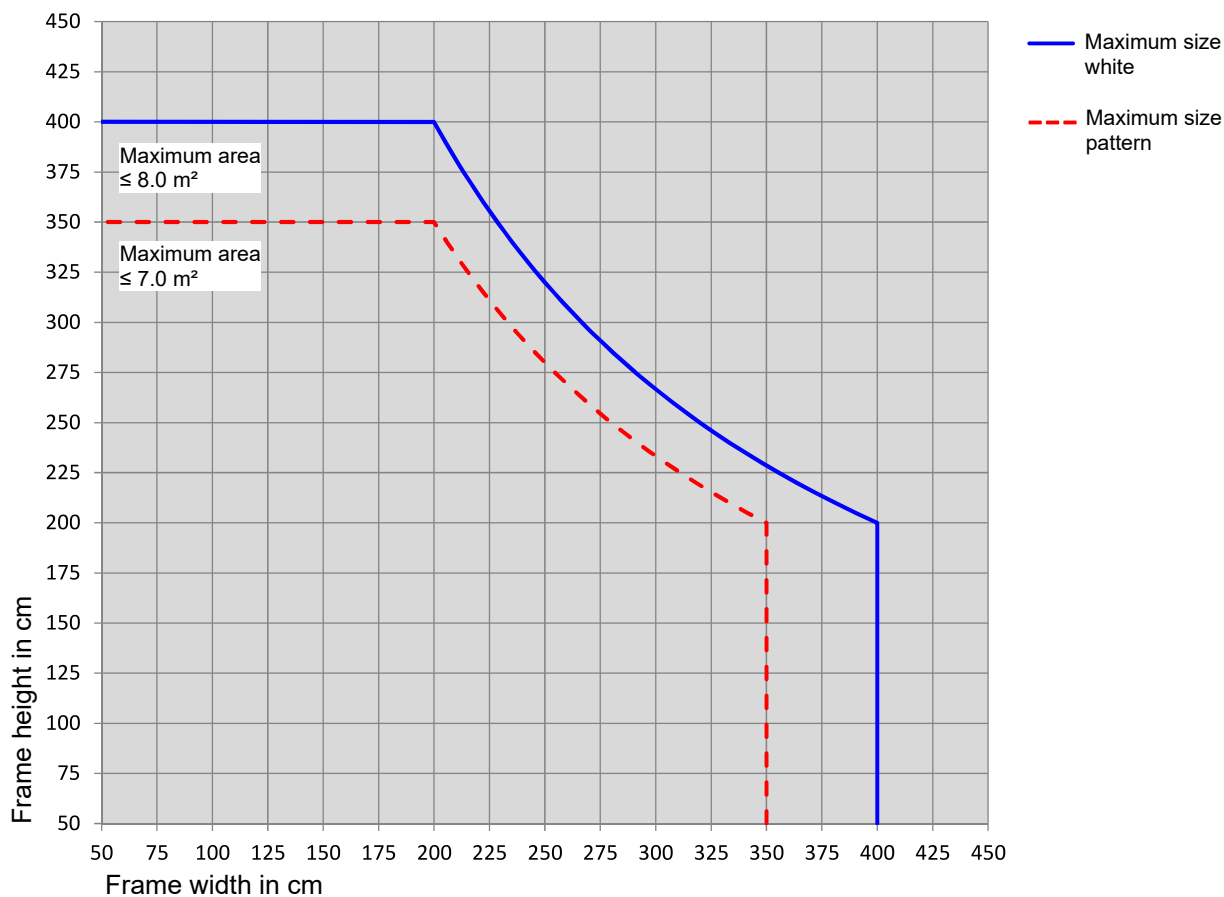

#### **i** INFO

- ▶ Maximum 350 kg glass weight for fixed glazing.
- ▶ Match the installation to:
  - structural substrates,
  - structural requirements, e.g.
    - wind load,
    - fall protection,
    - element weight,
  - position of the window element, e.g.
    - prewall installation,
    - on the reveal edge,
    - in the reveal,
  - fixing material,
  - use and type of reinforcing profile.

**To the size diagrams**

The following size diagrams show the outer dimensions of the sashes.

The sash size is determined by:

- the static values ( $l_x$ ,  $l_y$ ) of the bracing used
- the total glass thickness and the pane weight
- the acting loads, e.g. wind load and thermal load
- the fittings used and the specifications of the fittings manufacturer.

**Determination of total glass thickness**

- ▶ Add up the glass thicknesses of the individual glass panes.
- ▶ Do not take gap into account.

**Example:**

- Per pane = 4 mm glass thickness.
- Each gap = 12 mm.
- Structure 4 – 12 – 4 – 12 – 4.

Total glass thickness: **4 + 4 + 4 = 12 mm.**

**Calculation of pane weight**

- ▶ Area ( $m^2$ ) x total glass thickness x 2.5

**Example:**

1  $m^2$  glass weighs 30 kg.

- Density of glass = 2.5  $g/cm^3$ .
- Mass for flat glass = 2.5 kg per  $m^2$  and mm thickness.

Pane weight: **1  $m^2$  x 12 x 2.5 = 30 kg.**

**Wind loading**

For French window sashes (sashes with floating mullion), wind loading is according to grades 1 – 5 as per DIN EN 12210, permissible relative frontal deflection:  $B(l/200)$ , shown in the size diagram.

The  $l_y$  value of the steel used determines the resistance to wind loading.

Wind load lines are computed based on a symmetrical element structure and based on the real deflection at the test element and are only used for static pre-dimensioning. This does not replace an object-related static calculation in any case.

The wind zones for Germany are given in the following.

→ **see** [Chapter 5 Page 99](#)

**i INFO**

Different rules may apply for other countries.

- ▶ Check and if necessary apply these rules as a priority.

**Hardware**

Fittings must be suitable for leaf/casement size and leaf/casement weight.

- ▶ Observe the specifications of the hardware manufacturer.

Screw fastening of corner and stay hinge bearings in frame and fixed mullion:

- Up to 80 kg casement weight at least 2 screws in the reinforcing profile.
- Up to 100 kg casement weight at least 3 screws in the reinforcement profile.
- Up to 130 kg casement weight at least 4 screws in the reinforcing profile.

**i INFO**

Further information, e.g. our planning tool and our statics calculator can be found in the log-in area of our homepage [salamander-windows.com](http://salamander-windows.com).

Turn-only / Tilt&Turn sash

**VS8510-73**

Size chart for strengthening VS8510, 1.5 mm - single sash

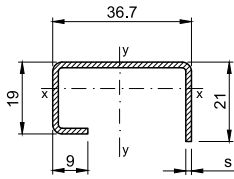

Application for sashes



HO8510

VS8510-73

Thickness

1.5 mm

$l_x = 0.58 \text{ cm}^4$

$l_y = 2.43 \text{ cm}^4$

Window type 1.1 Turn-only / bottom-hung window/door

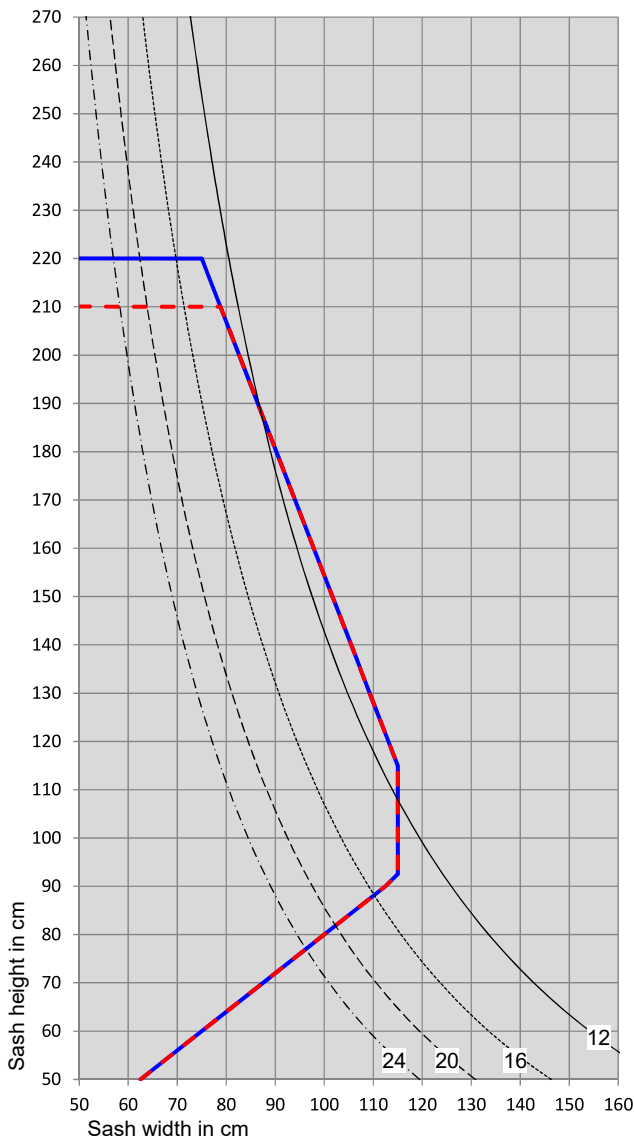
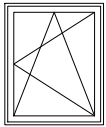

- Maximum size white
- - - Maximum size pattern
- 12 mm total glass thickness\*\*
- ..... 16 mm total glass thickness\*\*
- - - 20 mm total glass thickness\*\*
- · - · 24 mm total glass thickness\*\*

\*\*Sum of all glass panes without consideration of the gaps

Glass lines do NOT take into account the maximum permissible sash weight. Fittings must be suitable for sash size and sash weight. Further notes can be found in paragraph "Notes on sash sizes".

Turn-only / Tilt&Turn sash

**VS8510-73**

Size chart for strengthening VS8510, 1.5 mm - French window sash with narrow faceplate

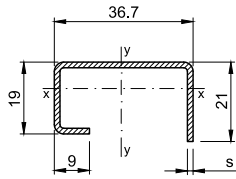

Application for sashes

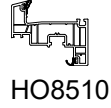

HO8510

VS8510-73  
Thickness  
1.5 mm  
 $I_x = 0.58 \text{ cm}^4$   
 $I_y = 2.43 \text{ cm}^4$

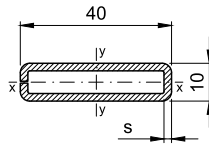

Application for faceplate

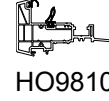

HO9810

VS9810-74  
Thickness  
2.0 mm  
 $I_x = 0.26 \text{ cm}^4$   
 $I_y = 2.77 \text{ cm}^4$

Window type 1.2 Turn-only / bottom-hung window/door

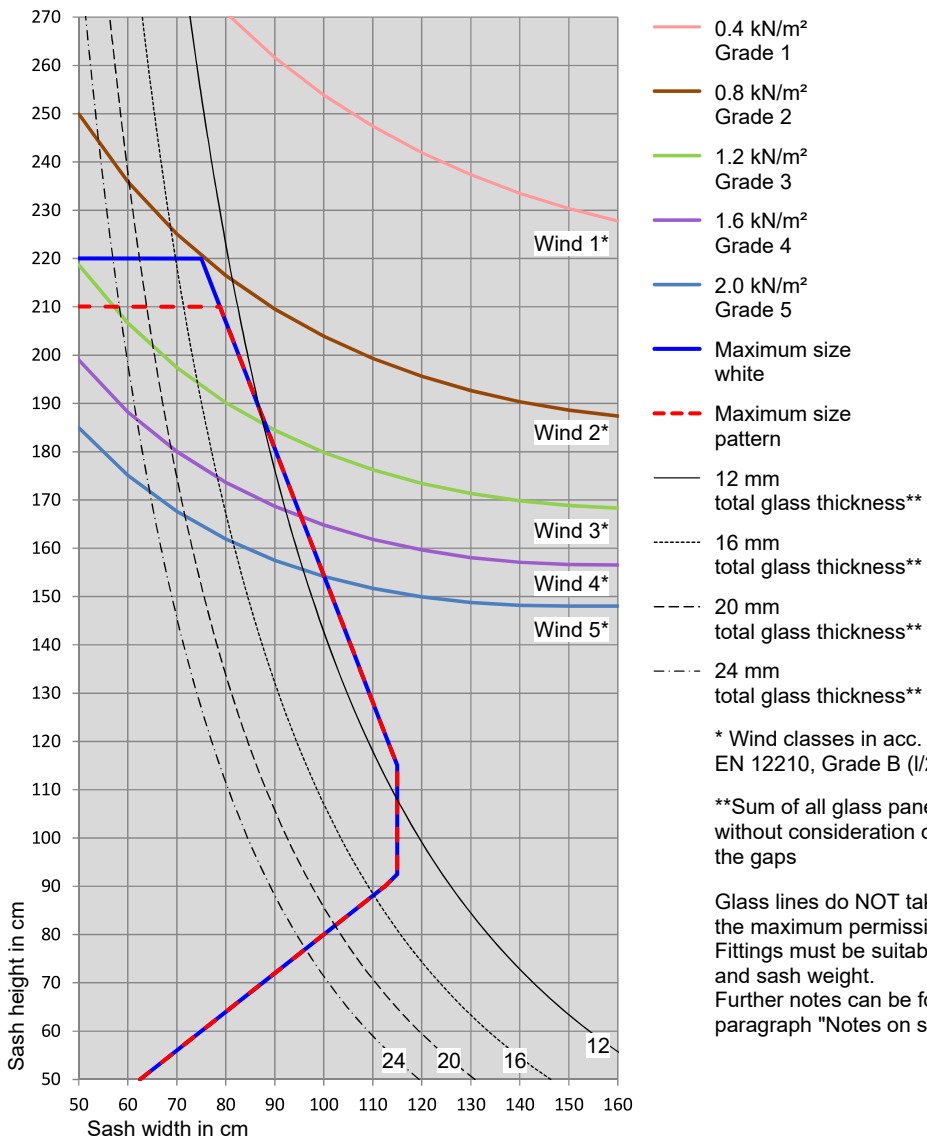
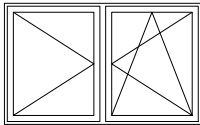

Turn-only / Tilt&Turn sash

**VS8510-73**

Size chart for strengthening VS8510, 1.5 mm - French window sash with wide faceplate

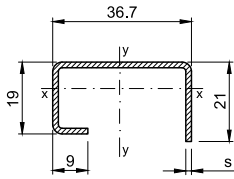

Application for sashes



HO8510

VS8510-73

Thickness

1.5 mm

$I_x = 0.58 \text{ cm}^4$

$I_y = 2.43 \text{ cm}^4$

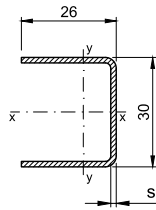

Application for faceplate



HO9800



HO9850



HO8800

VS8020-73

Thickness

1.5 mm

$I_x = 1.77 \text{ cm}^4$

$I_y = 0.82 \text{ cm}^4$

Window type 1.2 Turn-only / bottom-hung window/door

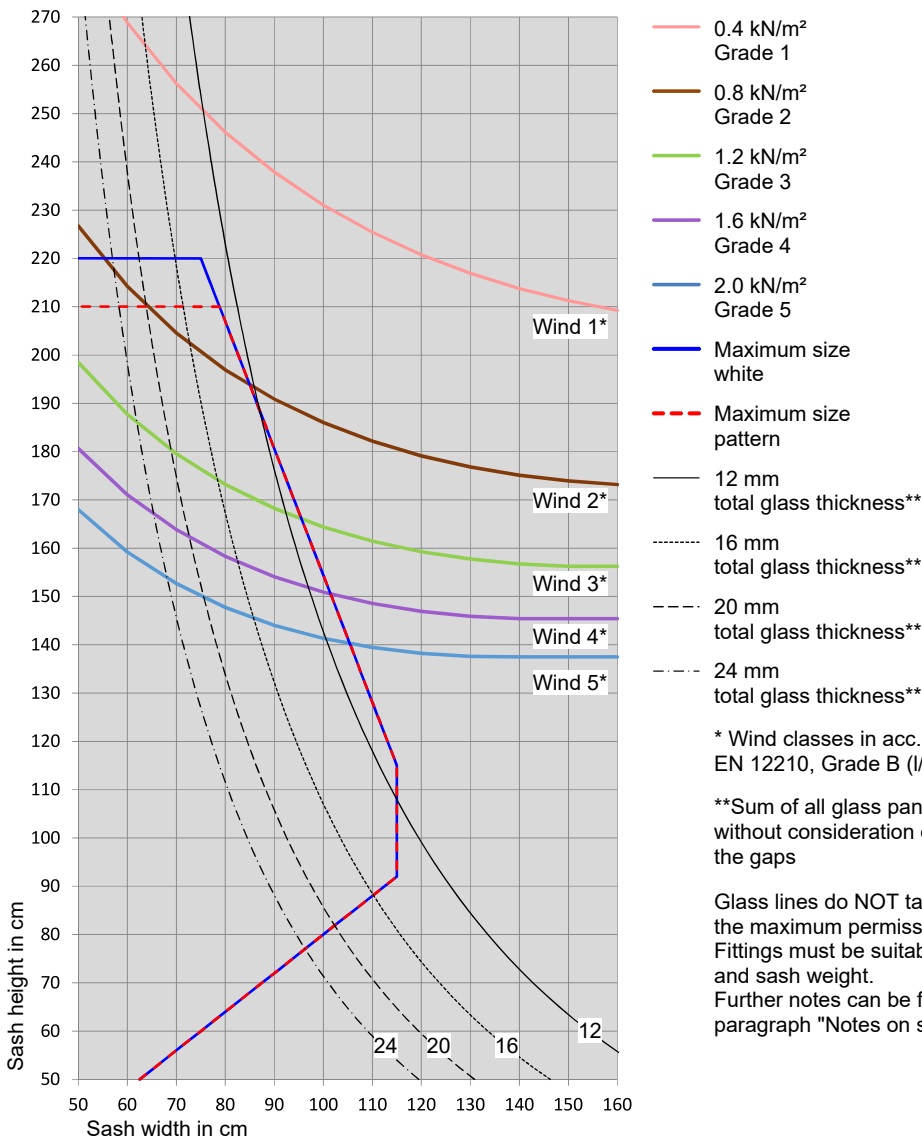
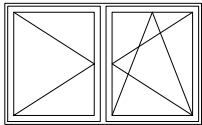

Turn-only / Tilt&Turn sash

**VS8510-73**

Size chart for strengthening VS8510, 1.5 mm - French window sash with wide faceplate

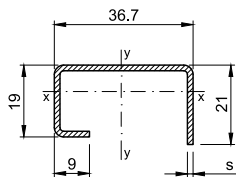

Application for sashes

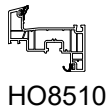

HO8510

VS8510-73  
 Thickness  
 1.5 mm  
 $lx = 0.58 \text{ cm}^4$   
 $ly = 2.43 \text{ cm}^4$

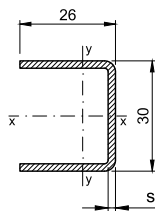

Application for faceplate

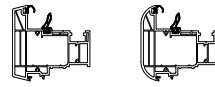

HO9800 HO9850



HO8800

VS8020-74  
 Thickness  
 2.0 mm  
 $lx = 2.26 \text{ cm}^4$   
 $ly = 1.06 \text{ cm}^4$

Window type 1.2 Turn-only / bottom-hung window/door

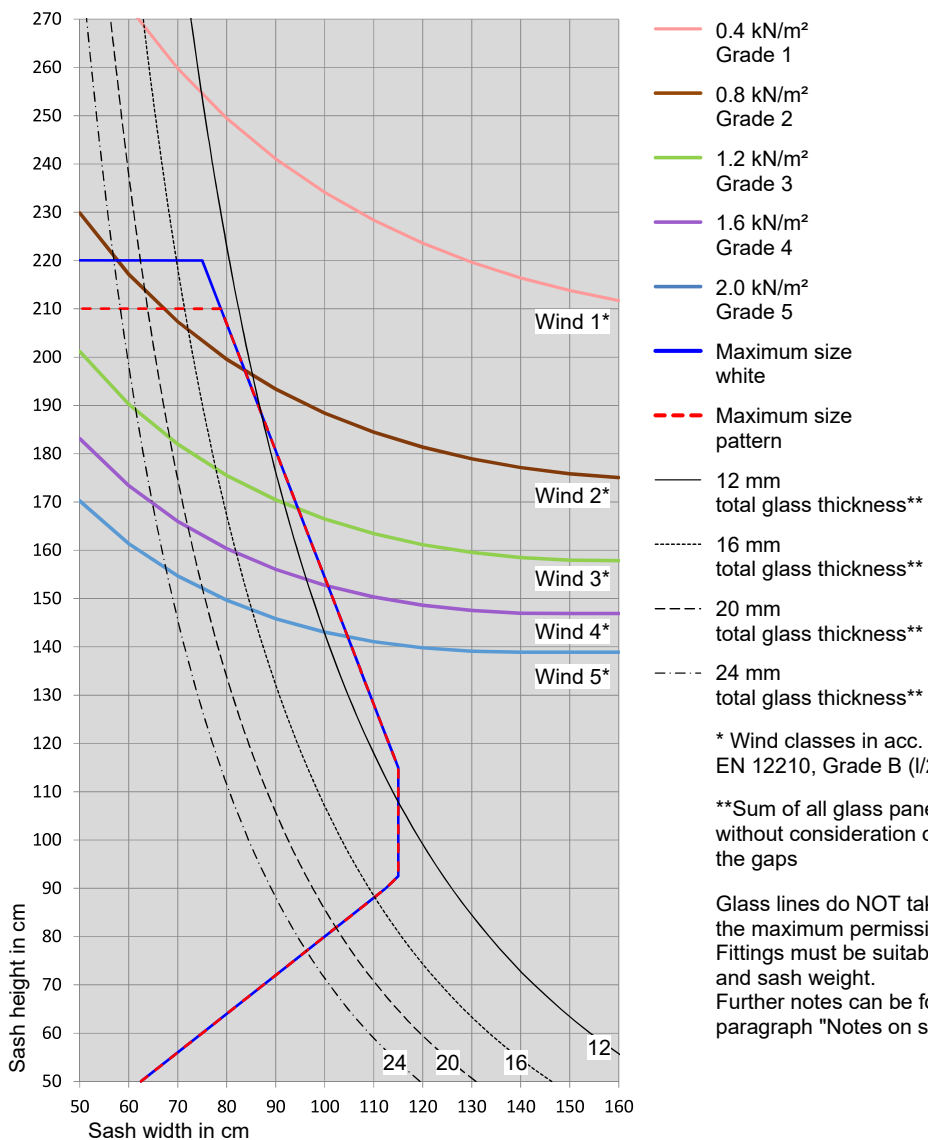
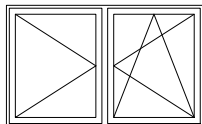

Turn-only / Tilt&Turn sash

**VS8510-73**

Size chart for strengthening VS8510, 1.5 mm - French window sash with wide faceplate

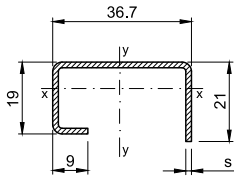

Application for sashes

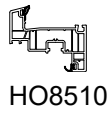

HO8510

VS8510-73

Thickness

1.5 mm

$I_x = 0.58 \text{ cm}^4$

$I_y = 2.43 \text{ cm}^4$

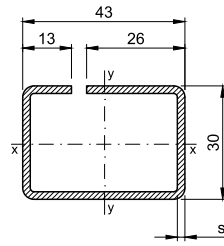

Application for faceplate

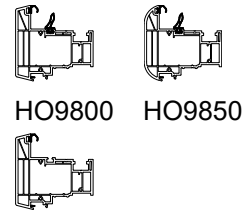

HO9800

HO9850

HO8800

VS9800-74

Thickness

2.0 mm

$I_x = 3.65 \text{ cm}^4$

$I_y = 6.65 \text{ cm}^4$

Window type 1.2 Turn-only / bottom-hung window/door

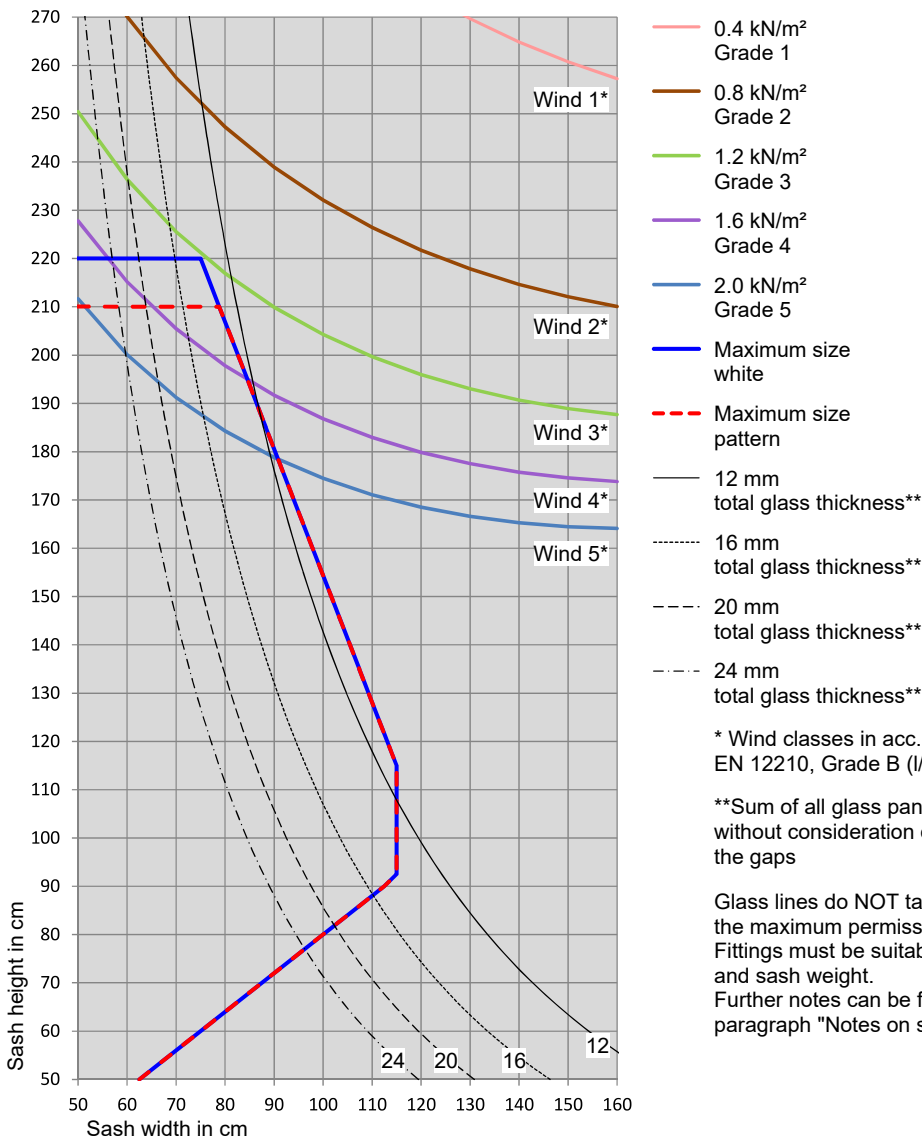
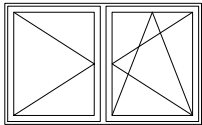

Turn-only / Tilt&Turn sash

**VS8510-74**

Size chart for strengthening VS8510, 2.0 mm - single sash

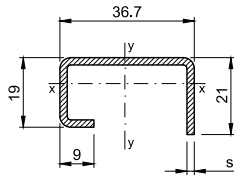

Application for sashes



HO8510

VS8510-74  
 Thickness  
 2.0 mm  
 $I_x = 0.72 \text{ cm}^4$   
 $I_y = 3.07 \text{ cm}^4$

Window type 1.1 Turn-only / bottom-hung window/door

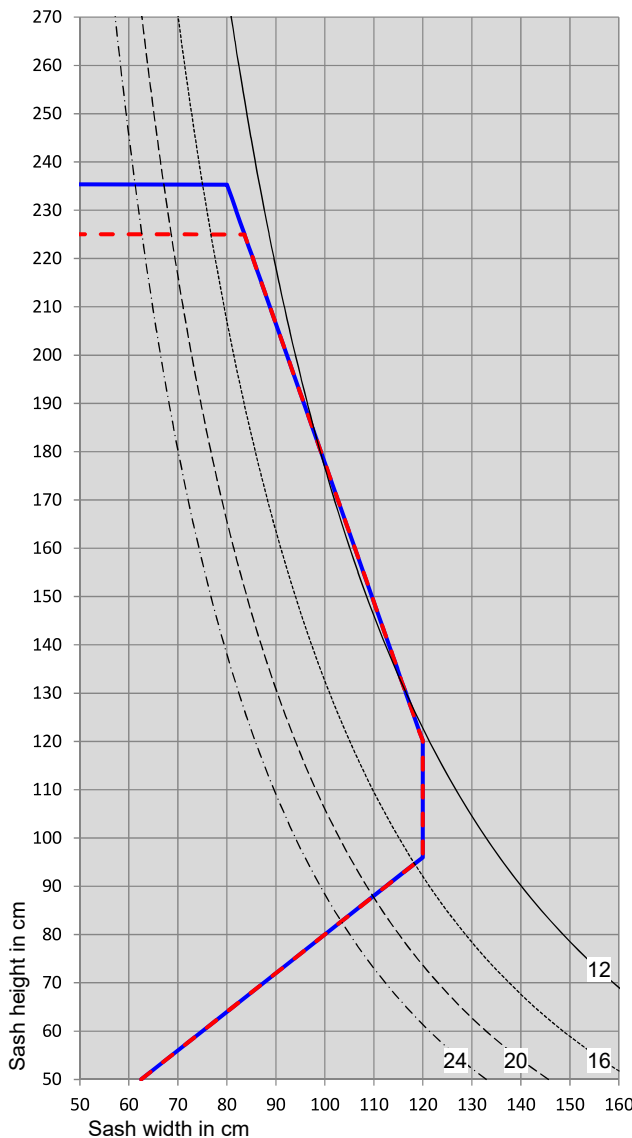
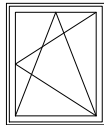

- Maximum size white
- - - Maximum size pattern
- 12 mm total glass thickness\*\*
- ..... 16 mm total glass thickness\*\*
- - - - 20 mm total glass thickness\*\*
- · - · - 24 mm total glass thickness\*\*

\*\*Sum of all glass panes without consideration of the gaps

Glass lines do NOT take into account the maximum permissible sash weight. Fittings must be suitable for sash size and sash weight. Further notes can be found in paragraph "Notes on sash sizes".

Turn-only / Tilt&Turn sash

**VS8510-74**

Size chart for strengthening VS8510, 2.0 mm - French window sash with narrow faceplate

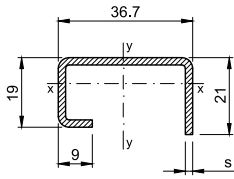

Application for sashes



HO8510

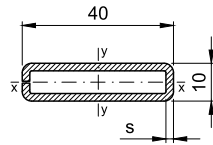

Application for faceplate

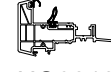

HO9810

VS8510-74  
Thickness  
2.0 mm  
 $I_x = 0.72 \text{ cm}^4$   
 $I_y = 3.07 \text{ cm}^4$

VS9810-74  
Thickness  
2.0 mm  
 $I_x = 0.26 \text{ cm}^4$   
 $I_y = 2.77 \text{ cm}^4$

Window type 1.2 Turn-only / bottom-hung window/door

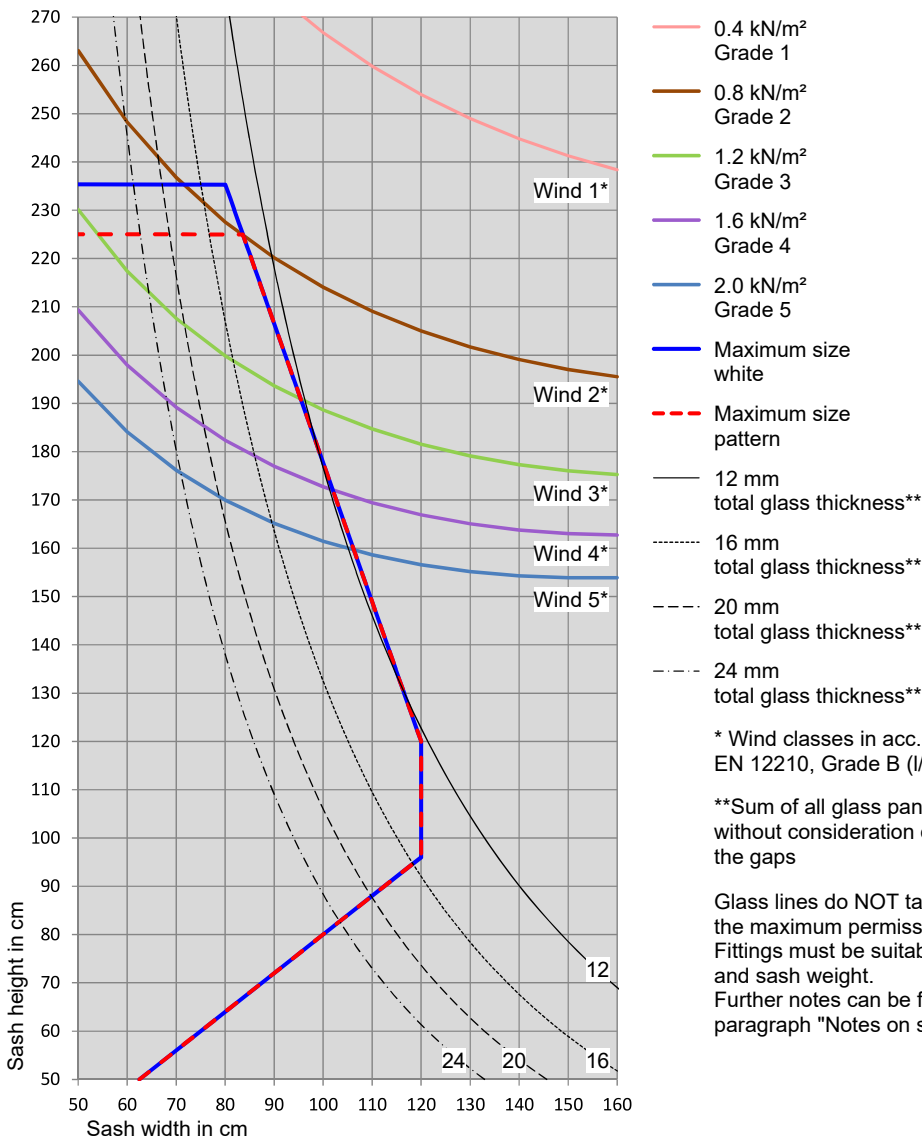
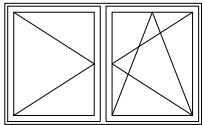

\* Wind classes in acc. with EN 12210, Grade B (I/200)

\*\*Sum of all glass panes without consideration of the gaps

Glass lines do NOT take into account the maximum permissible sash weight. Fittings must be suitable for sash size and sash weight. Further notes can be found in paragraph "Notes on sash sizes".

Turn-only / Tilt&Turn sash

**VS8510-74**

Size chart for strengthening VS8510, 2.0 mm - French window sash with wide faceplate

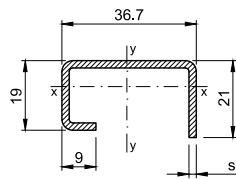

Application for sashes

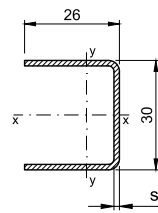
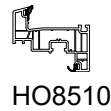

Application for faceplate

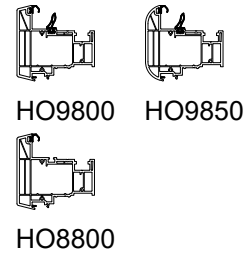

VS8510-74  
Thickness  
2.0 mm  
 $I_x = 0.72 \text{ cm}^4$   
 $I_y = 3.07 \text{ cm}^4$

VS8020-73  
Thickness  
1.5 mm  
 $I_x = 1.77 \text{ cm}^4$   
 $I_y = 0.82 \text{ cm}^4$

Window type 1.2 Turn-only / bottom-hung window/door

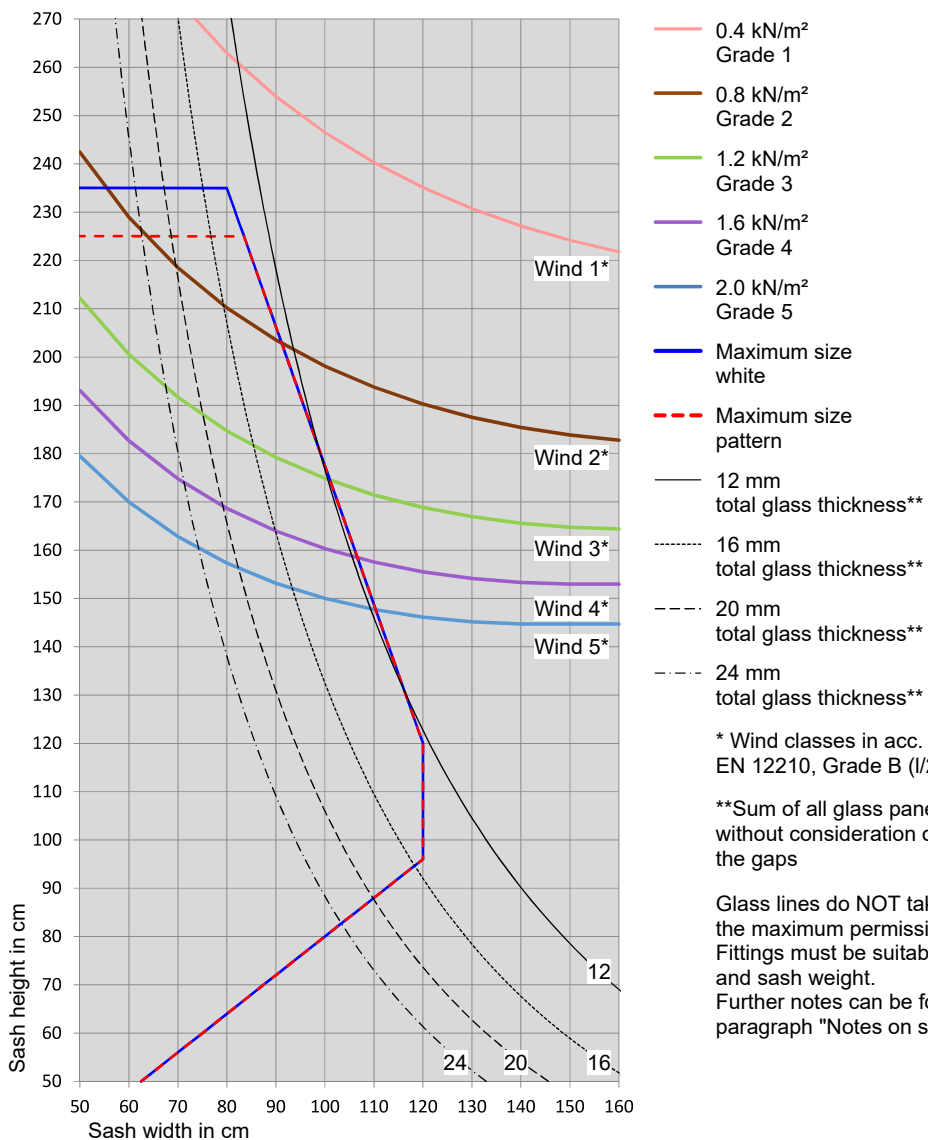
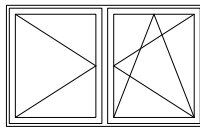

Turn-only / Tilt&Turn sash

**VS8510-74**

Size chart for strengthening VS8510, 2.0 mm - French window sash with wide faceplate

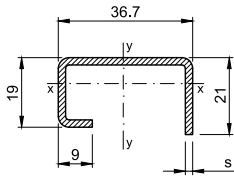

Application for sashes



HO8510

VS8510-74  
Thickness  
2.0 mm  
 $I_x = 0.72 \text{ cm}^4$   
 $I_y = 3.07 \text{ cm}^4$

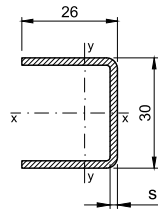

Application for faceplate

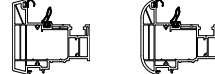

HO9800

HO9850



HO8800

VS8020-74  
Thickness  
2.0 mm  
 $I_x = 2.26 \text{ cm}^4$   
 $I_y = 1.06 \text{ cm}^4$

Window type 1.2 Turn-only / bottom-hung window/door

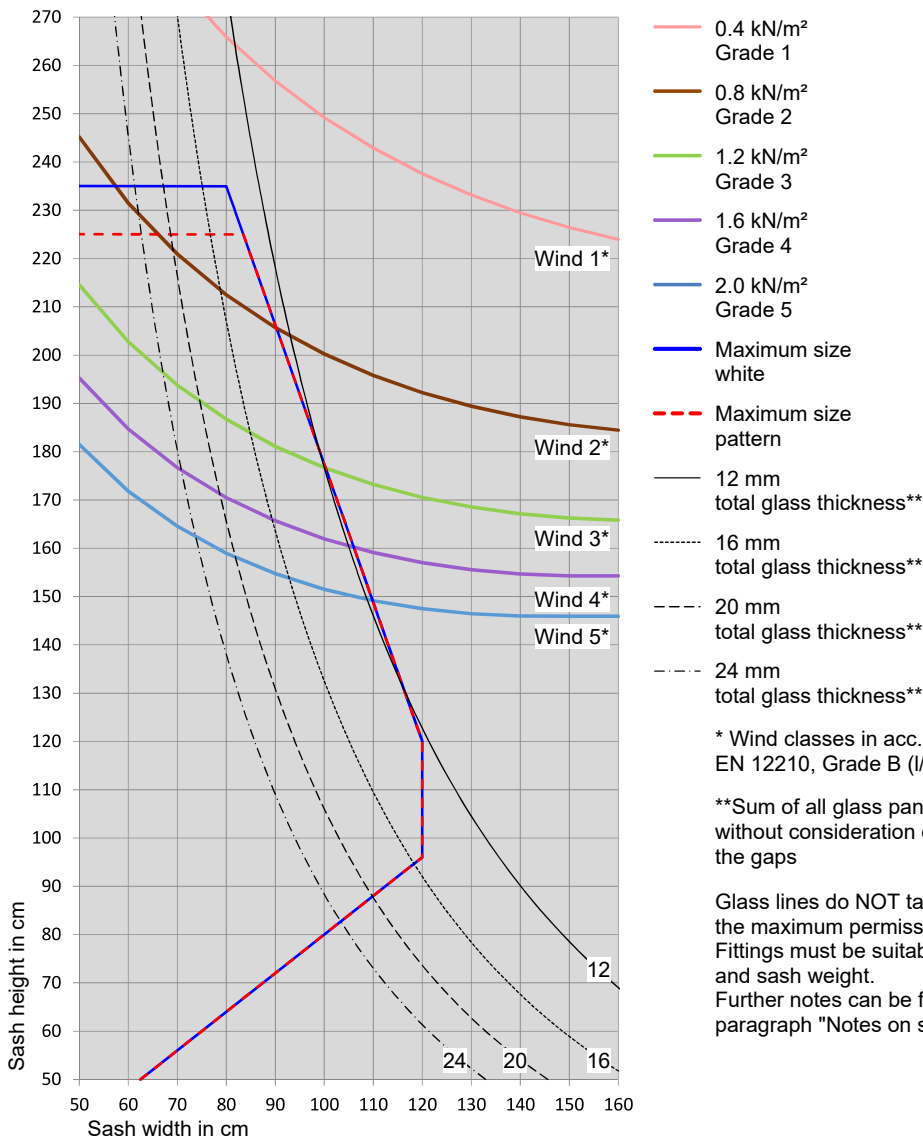
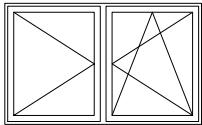

Turn-only / Tilt&Turn sash

**VS8510-74**

Size chart for strengthening VS8510, 2.0 mm - French window sash with wide faceplate

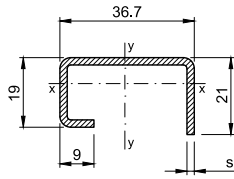

Application for sashes

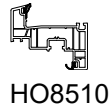

VS8510-74  
Thickness  
2.0 mm  
 $I_x = 0.72 \text{ cm}^4$   
 $I_y = 3.07 \text{ cm}^4$

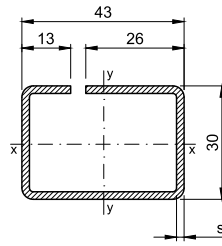

Application for faceplate

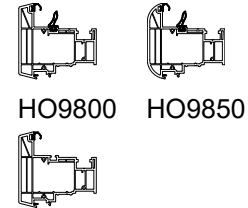

VS9800-74  
Thickness  
2.0 mm  
 $I_x = 3.65 \text{ cm}^4$   
 $I_y = 6.65 \text{ cm}^4$

HO8800

Window type 1.2 Turn-only / bottom-hung window/door

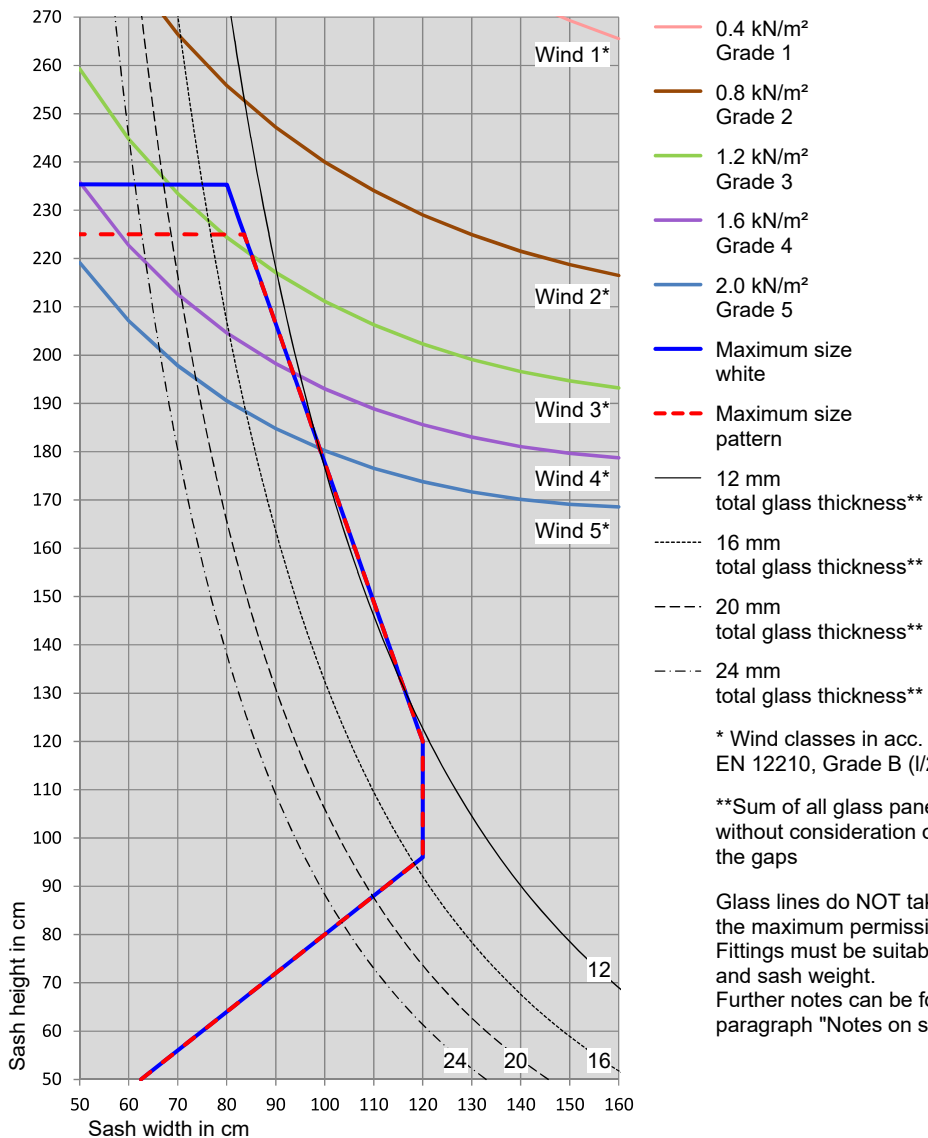
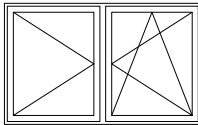

- 0.4 kN/m<sup>2</sup> Grade 1
- 0.8 kN/m<sup>2</sup> Grade 2
- 1.2 kN/m<sup>2</sup> Grade 3
- 1.6 kN/m<sup>2</sup> Grade 4
- 2.0 kN/m<sup>2</sup> Grade 5
- Maximum size white
- - - Maximum size pattern
- 12 mm total glass thickness\*\*
- ..... 16 mm total glass thickness\*\*
- - - 20 mm total glass thickness\*\*
- - - 24 mm total glass thickness\*\*

\* Wind classes in acc. with EN 12210, Grade B (I/200)

\*\*Sum of all glass panes without consideration of the gaps

Glass lines do NOT take into account the maximum permissible sash weight. Fittings must be suitable for sash size and sash weight. Further notes can be found in paragraph "Notes on sash sizes".

Turn-Only/Tilt&Turn sash

**VS8020-73**

Size chart for strengthening VS8020, 1.5 mm - single sash

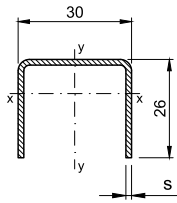

Application for sashes



HO8520



HO8521



HP8920

VS8020-73

Thickness

1.5 mm

$I_x = 0.82 \text{ cm}^4$

$I_y = 1.77 \text{ cm}^4$

Window type 1.1 Turn-only / bottom-hung window/door

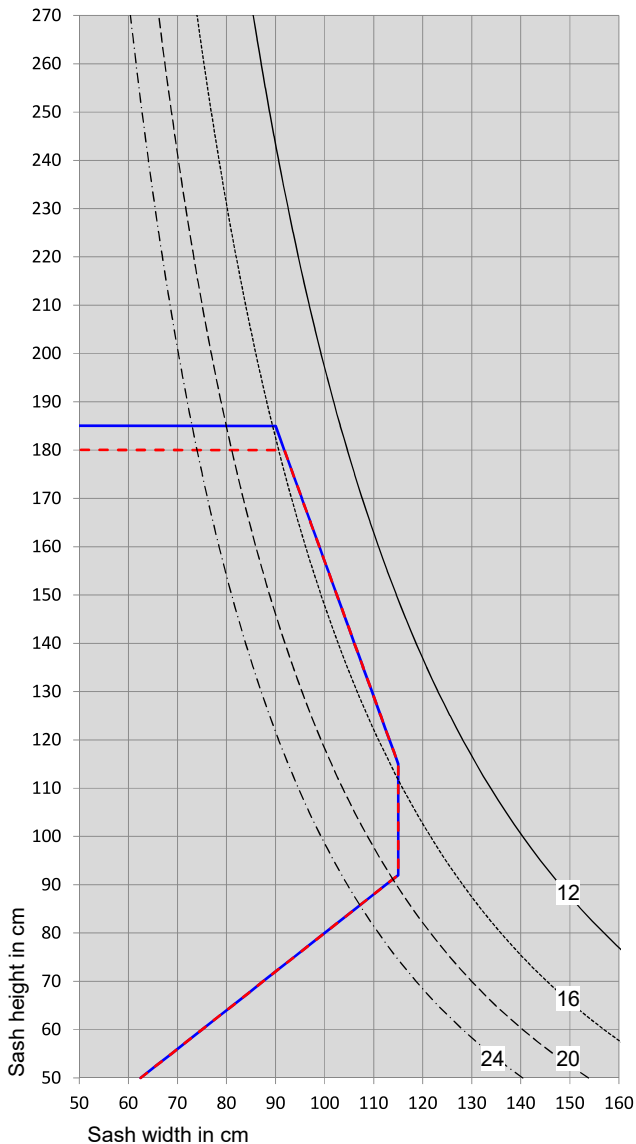
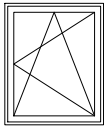

- Maximum size white
- - - Maximum size pattern
- 12 mm total glass thickness\*\*
- ..... 16 mm total glass thickness\*\*
- - - 20 mm total glass thickness\*\*
- · - · 24 mm total glass thickness\*\*

\*\*Sum of all glass panes without consideration of the gaps

Glass lines do NOT take into account the maximum permissible sash weight. Fittings must be suitable for sash size and sash weight. Further notes can be found in paragraph "Notes on sash sizes".

Turn-Only/Tilt&Turn sash

**VS8020-73**

Size chart for strengthening VS8020, 1.5 mm - French window sash with wide faceplate

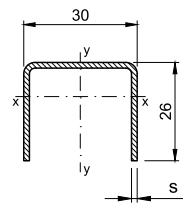

VS8020-73  
Thickness 1,5 mm  
 $l_x = 0.82 \text{ cm}^4$   
 $l_y = 1.77 \text{ cm}^4$

Application for sashes

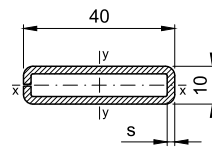
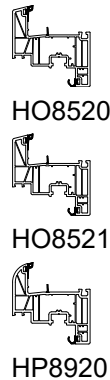

VS9810-74  
Thickness 2.0 mm  
 $l_x = 0.26 \text{ cm}^4$   
 $l_y = 2.77 \text{ cm}^4$

Application for faceplate

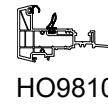

Window type 1.2 Turn-only / bottom-hung window/door

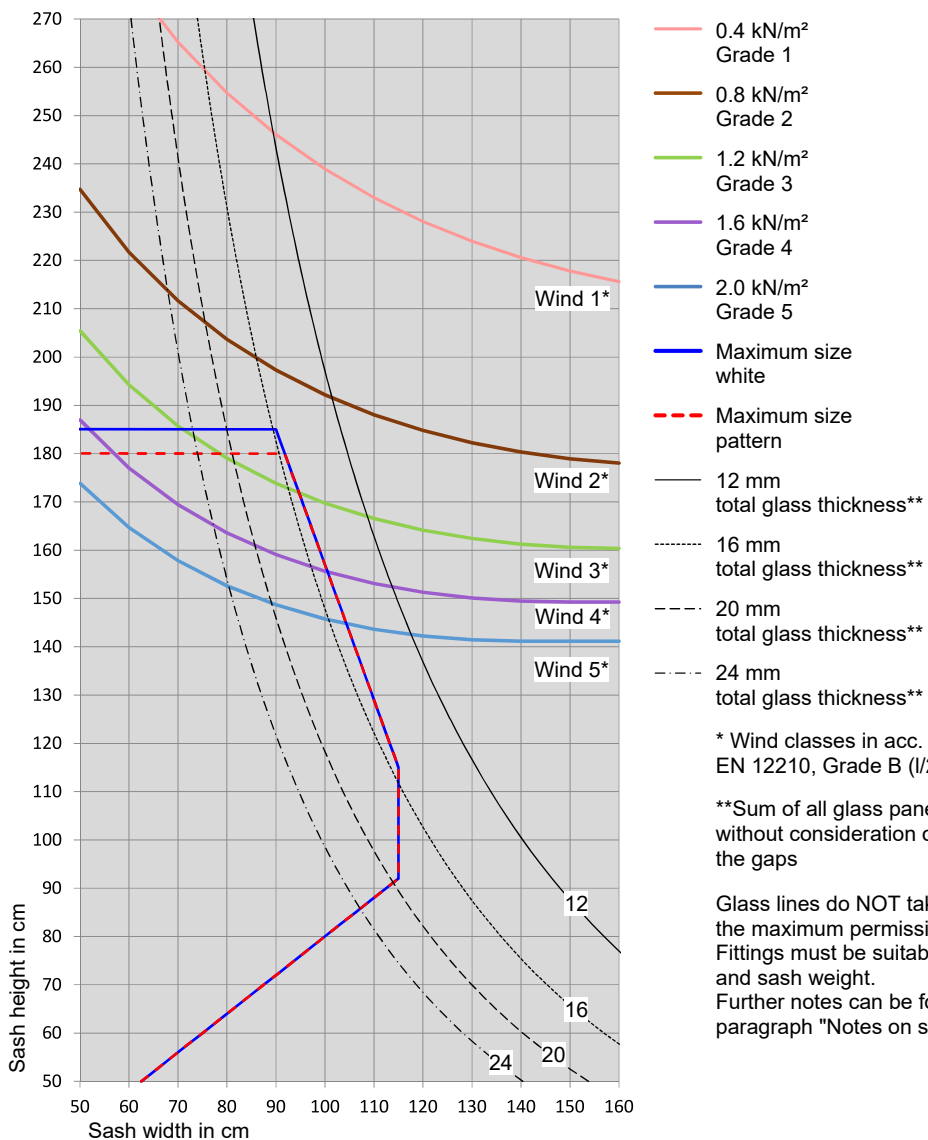
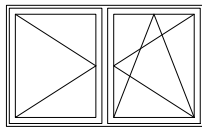



Turn-Only/Tilt&Turn sash

VS8020-73

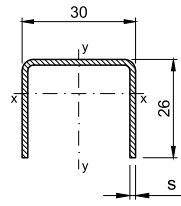
Size chart for strengthening VS8020, 1.5 mm - French window sash with wide faceplate





Application for sashes

-  HO8520
-  HO8521
-  HP8920

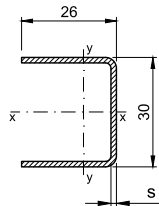
VS8020-73  
Thickness  
1.5 mm  
 $I_x = 0.82 \text{ cm}^4$   
 $I_y = 1.77 \text{ cm}^4$



Application for faceplate

-  HO9800
-  HO9850
-  HO8800

VS8020-73  
Thickness  
1.5 mm  
 $I_x = 1.77 \text{ cm}^4$   
 $I_y = 0.82 \text{ cm}^4$

Window type 1.2 Turn-only / bottom-hung window/door

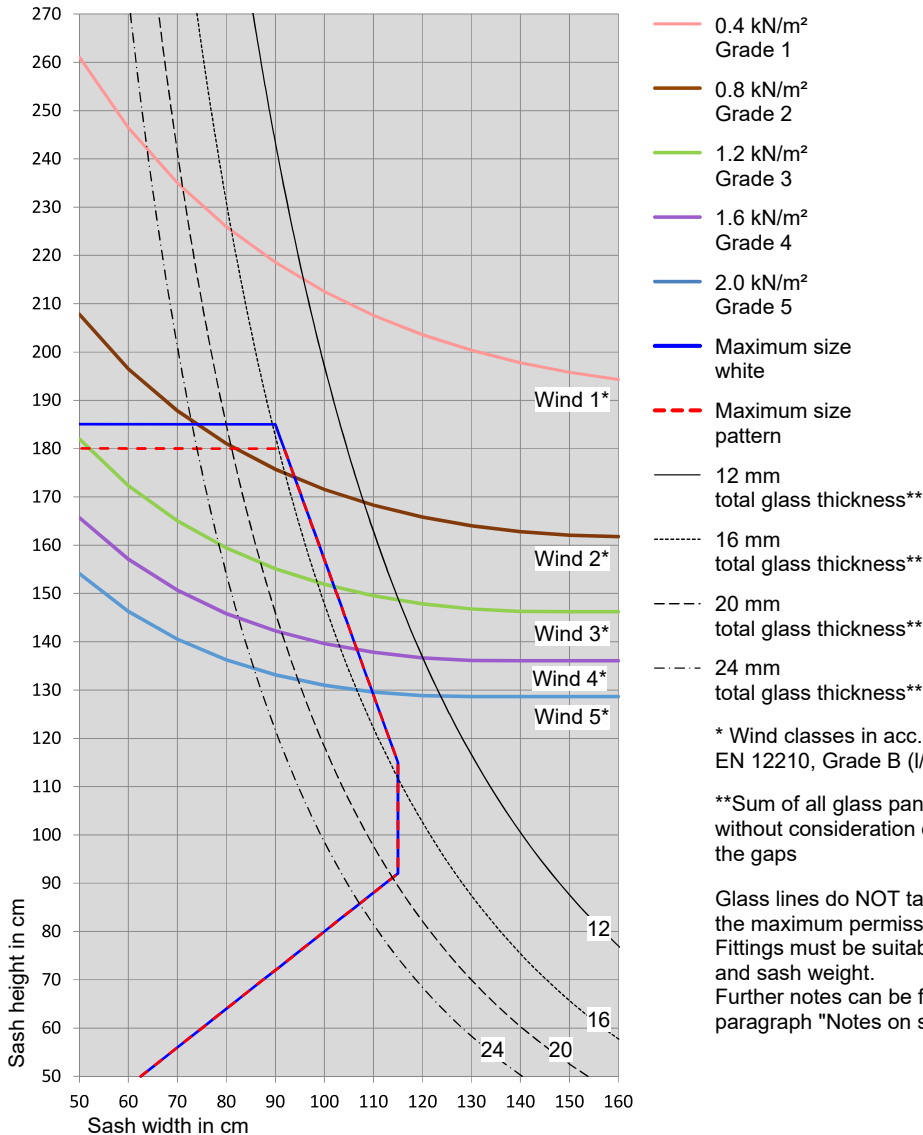
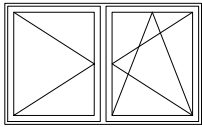

Turn-Only/Tilt&Turn sash

**VS8020-73**

Size chart for strengthening VS8020, 1.5 mm - French window sash with wide faceplate

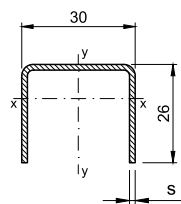

Application for sashes

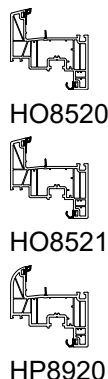

VS8020-73  
Thickness  
1.5 mm  
 $I_x = 0.82 \text{ cm}^4$   
 $I_y = 1.77 \text{ cm}^4$

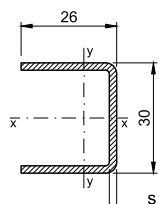

Application for faceplate

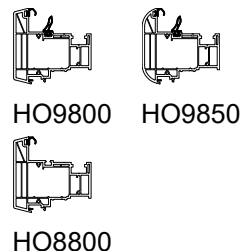

VS8020-74  
Thickness  
2.0 mm  
 $I_x = 2.26 \text{ cm}^4$   
 $I_y = 1.06 \text{ cm}^4$

Window type 1.2 Turn-only / bottom-hung window/door

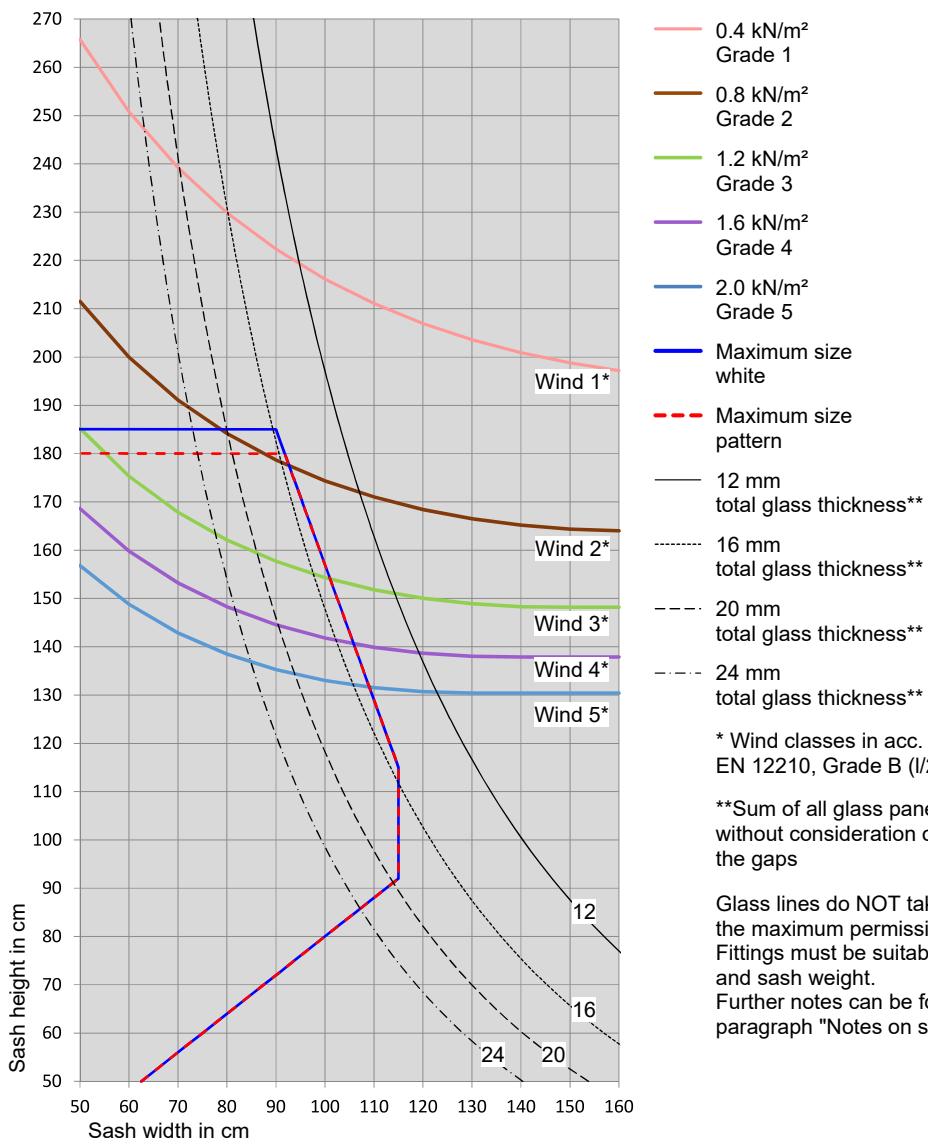
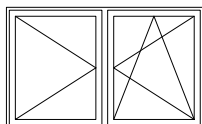

- 0.4 kN/m<sup>2</sup> Grade 1
- 0.8 kN/m<sup>2</sup> Grade 2
- 1.2 kN/m<sup>2</sup> Grade 3
- 1.6 kN/m<sup>2</sup> Grade 4
- 2.0 kN/m<sup>2</sup> Grade 5
- Maximum size white
- - - Maximum size pattern
- 12 mm total glass thickness\*\*
- · - · - 16 mm total glass thickness\*\*
- - - - 20 mm total glass thickness\*\*
- · - · - 24 mm total glass thickness\*\*

\* Wind classes in acc. with EN 12210, Grade B (I/200)

\*\*Sum of all glass panes without consideration of the gaps

Glass lines do NOT take into account the maximum permissible sash weight. Fittings must be suitable for sash size and sash weight. Further notes can be found in paragraph "Notes on sash sizes".



Turn-Only/Tilt&Turn sash

VS8020-73

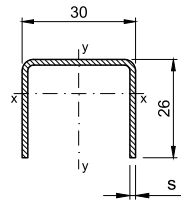
Size chart for strengthening VS8020, 1.5 mm - French window sash with wide faceplate





Application for sashes

-  HO8520
-  HO8521
-  HP8920

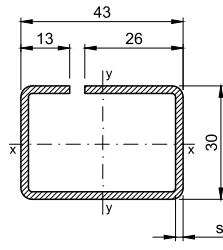
VS8020-73  
Thickness  
1.5 mm  
 $I_x = 0.82 \text{ cm}^4$   
 $I_y = 1.77 \text{ cm}^4$



Application for faceplate

-  HO9800
-  HO9850
-  HO8800

VS9800-74  
Thickness  
2.0 mm  
 $I_x = 3.65 \text{ cm}^4$   
 $I_y = 6.65 \text{ cm}^4$

Window type 1.2 Turn-only / bottom-hung window/door

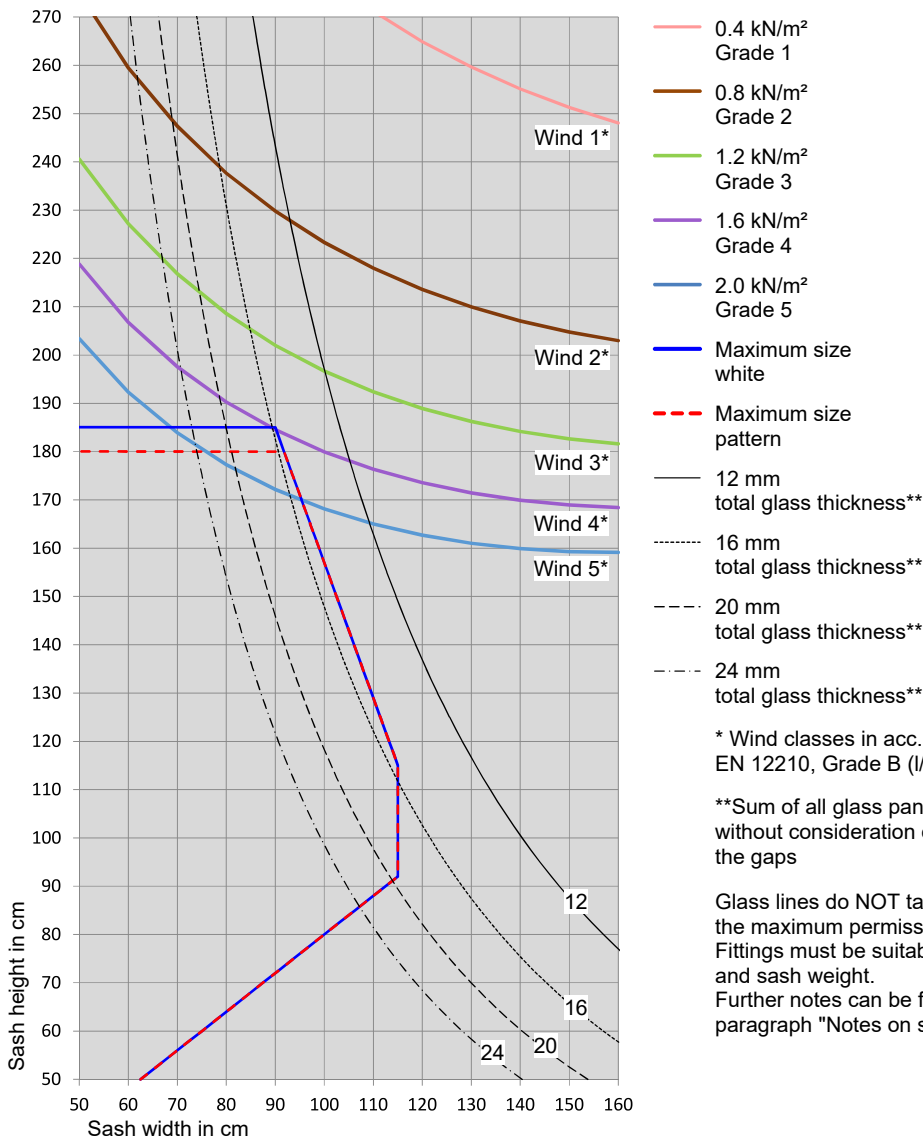
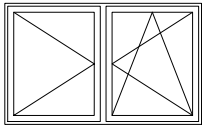

Turn-only / Tilt&Turn sash

**VS8020-74**

Size chart for strengthening VS8020, 2.0 mm - single sash

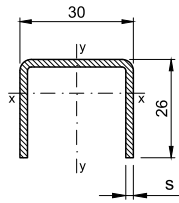

VS8020-74  
Thickness  
2.0 mm  
 $l_x = 1.06 \text{ cm}^4$   
 $l_y = 2.26 \text{ cm}^4$

Application for sashes



HO8520



HO8521



HP8920

Window type 1.1 Turn-only / bottom-hung window/door

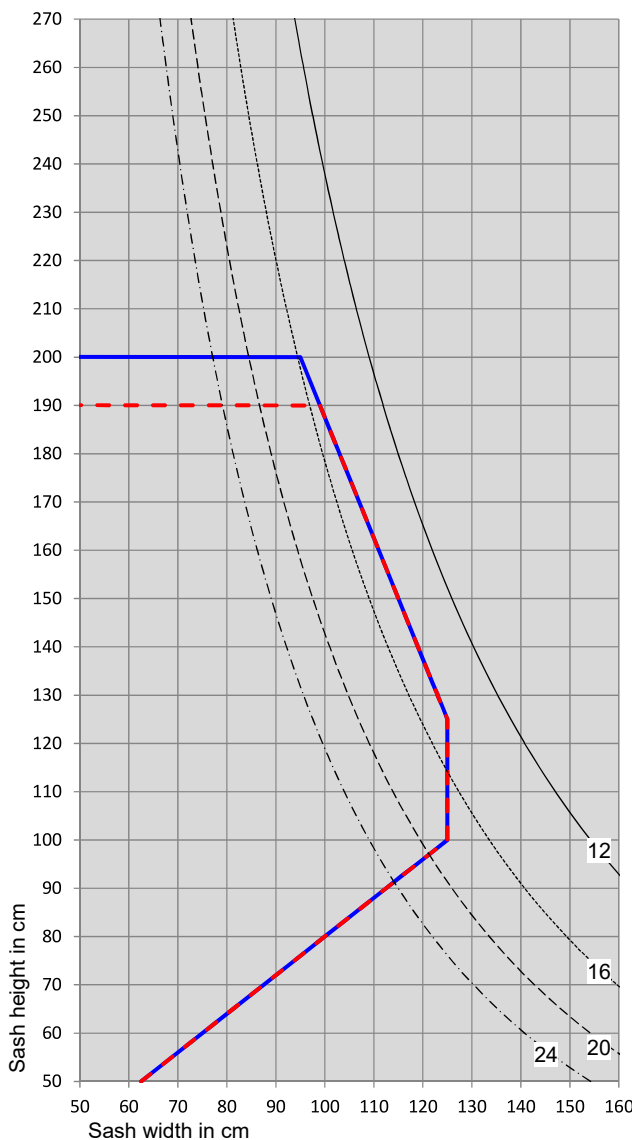
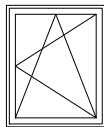

- Maximum size white
- - - Maximum size pattern
- 12 mm total glass thickness\*\*
- ..... 16 mm total glass thickness\*\*
- - - 20 mm total glass thickness\*\*
- . - . 24 mm total glass thickness\*\*

\*\*Sum of all glass panes without consideration of the gaps

Glass lines do NOT take into account the maximum permissible sash weight. Fittings must be suitable for sash size and sash weight. Further notes can be found in paragraph "Notes on sash sizes".

Turn-only / Tilt&Turn sash

**VS8020-74**

Size chart for strengthening VS8020, 2.0 mm - French window sash with wide faceplate

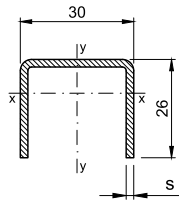

VS8020-74  
Thickness  
2.0 mm  
 $I_x = 1.06 \text{ cm}^4$   
 $I_y = 2.26 \text{ cm}^4$

Application for sashes



HO8520



HO8521



HP8920

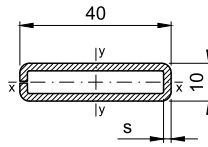

Application for faceplate



HO9810

VS9810-74  
Thickness  
2.0 mm  
 $I_x = 0.26 \text{ cm}^4$   
 $I_y = 2.77 \text{ cm}^4$

Window type 1.2 Turn-only / bottom-hung window/door

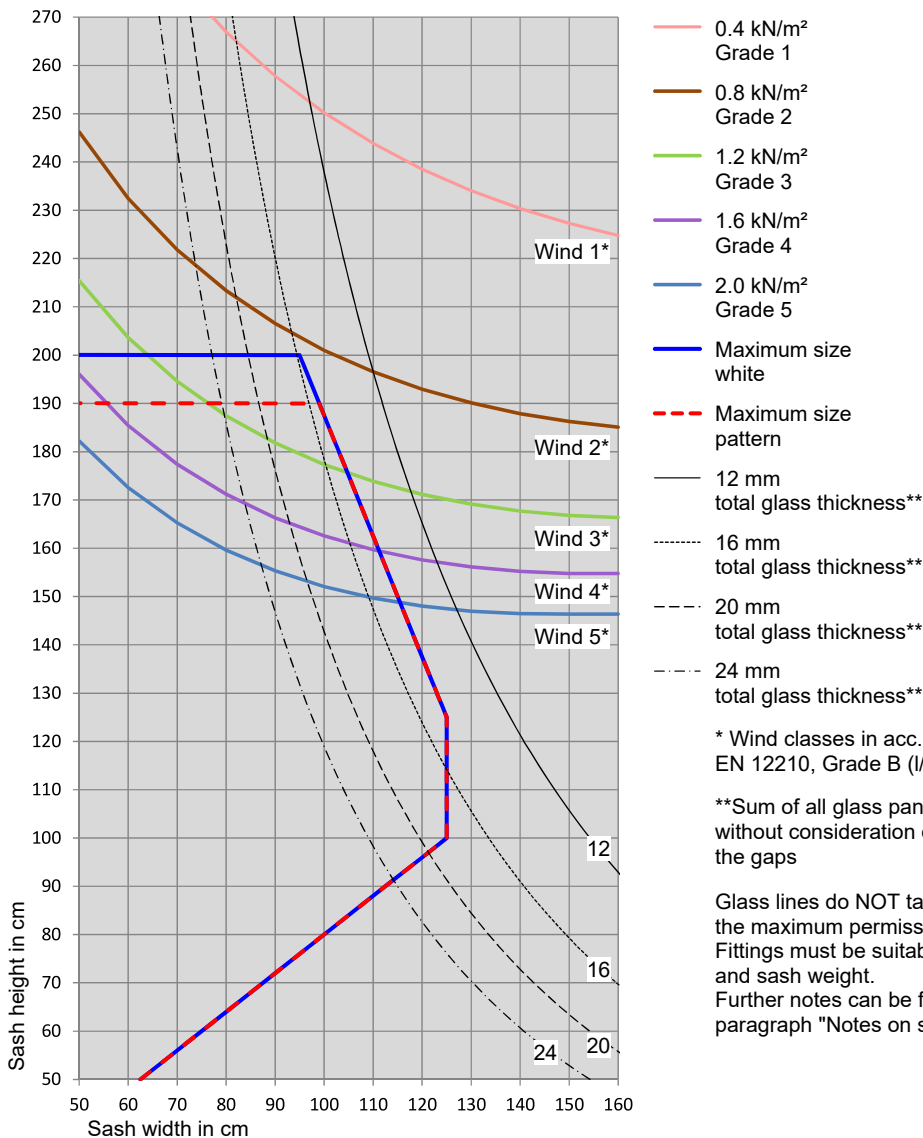
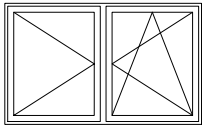

Turn-only / Tilt&Turn sash

**VS8020-74**

Size chart for strengthening VS8020, 2.0 mm - French window sash with wide faceplate

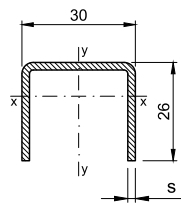

VS8020-74  
Thickness  
2.0 mm  
 $I_x = 1.06 \text{ cm}^4$   
 $I_y = 2.26 \text{ cm}^4$

Application for sashes

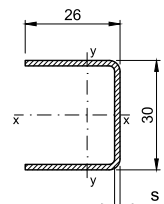
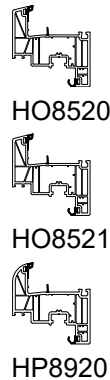

VS8020-73  
Thickness 1,5 mm  
 $I_x = 1.77 \text{ cm}^4$   
 $I_y = 0.82 \text{ cm}^4$

Application for faceplate

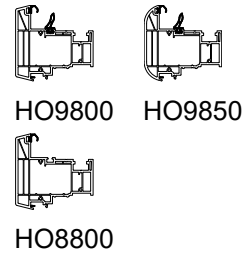

Window type 1.2 Turn-only / bottom-hung window/door

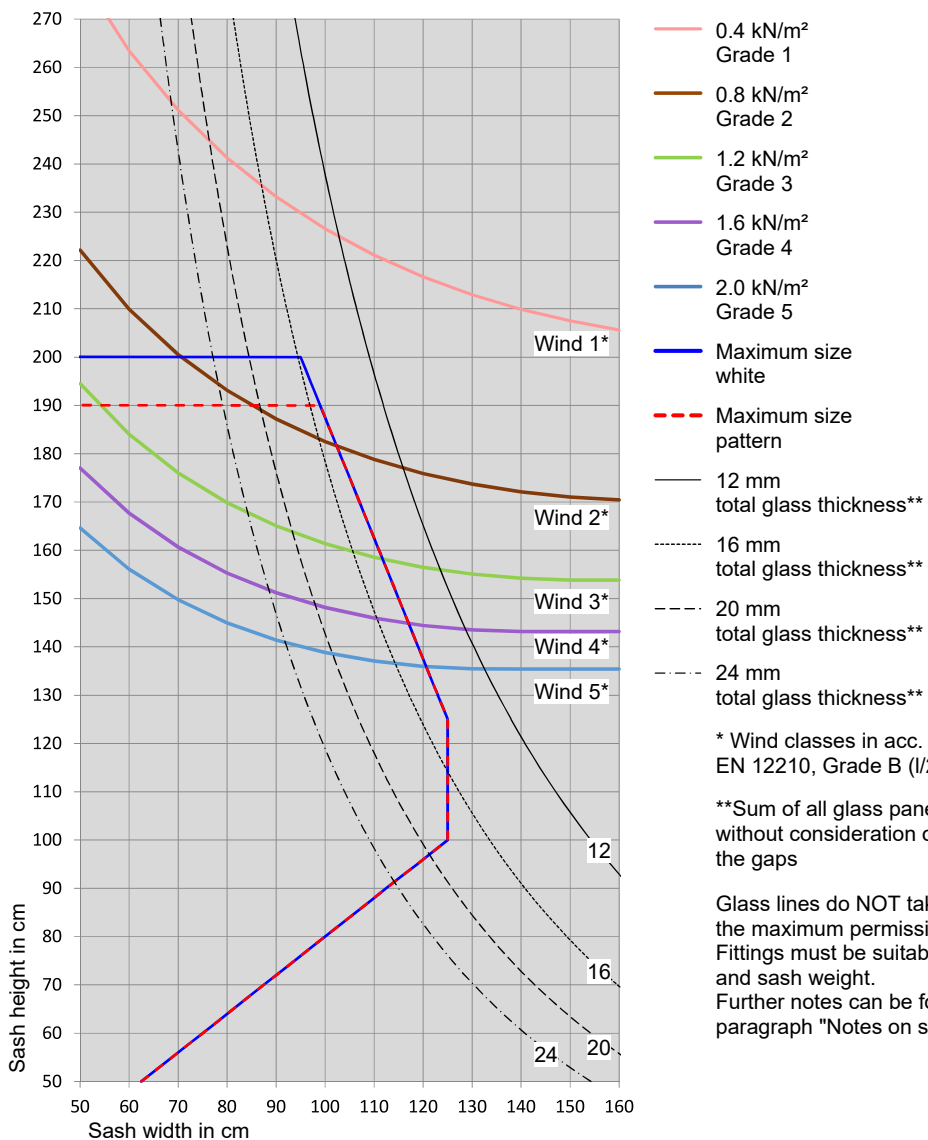
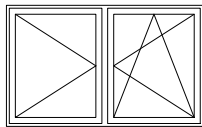

- 0.4 kN/m<sup>2</sup> Grade 1
- 0.8 kN/m<sup>2</sup> Grade 2
- 1.2 kN/m<sup>2</sup> Grade 3
- 1.6 kN/m<sup>2</sup> Grade 4
- 2.0 kN/m<sup>2</sup> Grade 5
- Maximum size white
- - - Maximum size pattern
- 12 mm total glass thickness\*\*
- · - · - 16 mm total glass thickness\*\*
- - - - 20 mm total glass thickness\*\*
- · - · - 24 mm total glass thickness\*\*

\* Wind classes in acc. with EN 12210, Grade B (I/200)

\*\*Sum of all glass panes without consideration of the gaps

Glass lines do NOT take into account the maximum permissible sash weight. Fittings must be suitable for sash size and sash weight. Further notes can be found in paragraph "Notes on sash sizes".

Turn-only / Tilt&Turn sash

**VS8020-74**

Size chart for strengthening VS8020, 2.0 mm - French window sash with wide faceplate

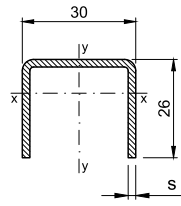

Application for sashes



HO8520



HO8521



HP8920

VS8020-74  
Thickness  
2.0 mm  
 $I_x = 1.06 \text{ cm}^4$   
 $I_y = 2.26 \text{ cm}^4$

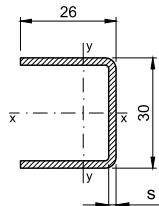

Application for faceplate



HO9800



HO9850



HO8800

VS8020-74  
Thickness  
2.0 mm  
 $I_x = 2.26 \text{ cm}^4$   
 $I_y = 1.06 \text{ cm}^4$

Window type 1.2 Turn-only / bottom-hung window/door

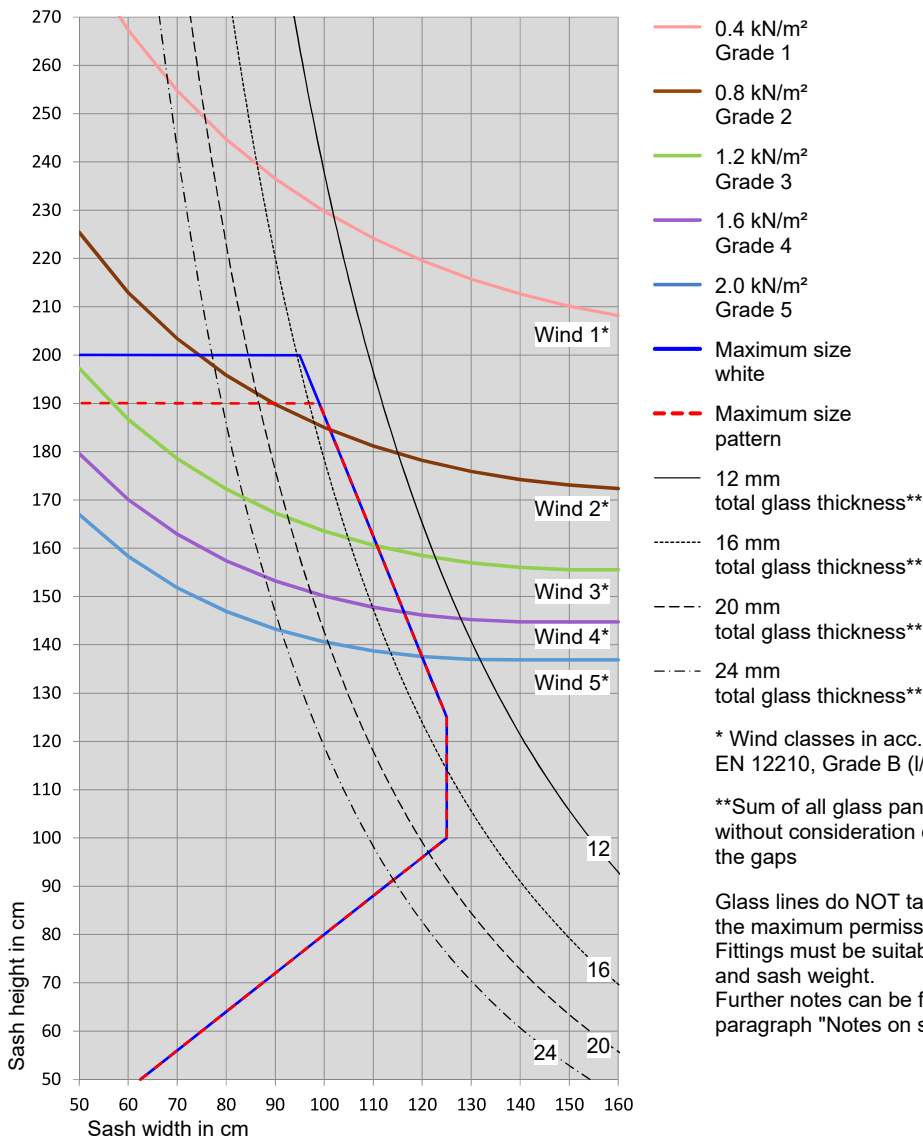
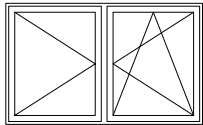

Turn-only / Tilt&Turn sash

**VS8020-74**

Size chart for strengthening VS8020, 2.0 mm - French window sash with wide faceplate

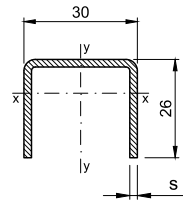

VS8020-74  
Thickness  
2.0 mm  
 $I_x = 1.06 \text{ cm}^4$   
 $I_y = 2.26 \text{ cm}^4$

Application for sashes

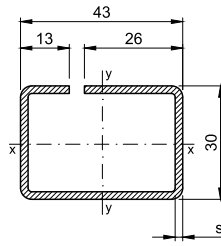
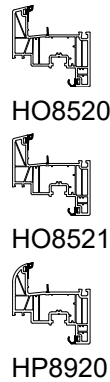

VS9800-74  
Thickness  
2.0 mm  
 $I_x = 3.65 \text{ cm}^4$   
 $I_y = 6.65 \text{ cm}^4$

Application for faceplate

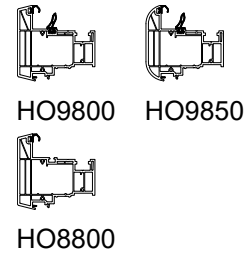

Window type 1.2 Turn-only / bottom-hung window/door

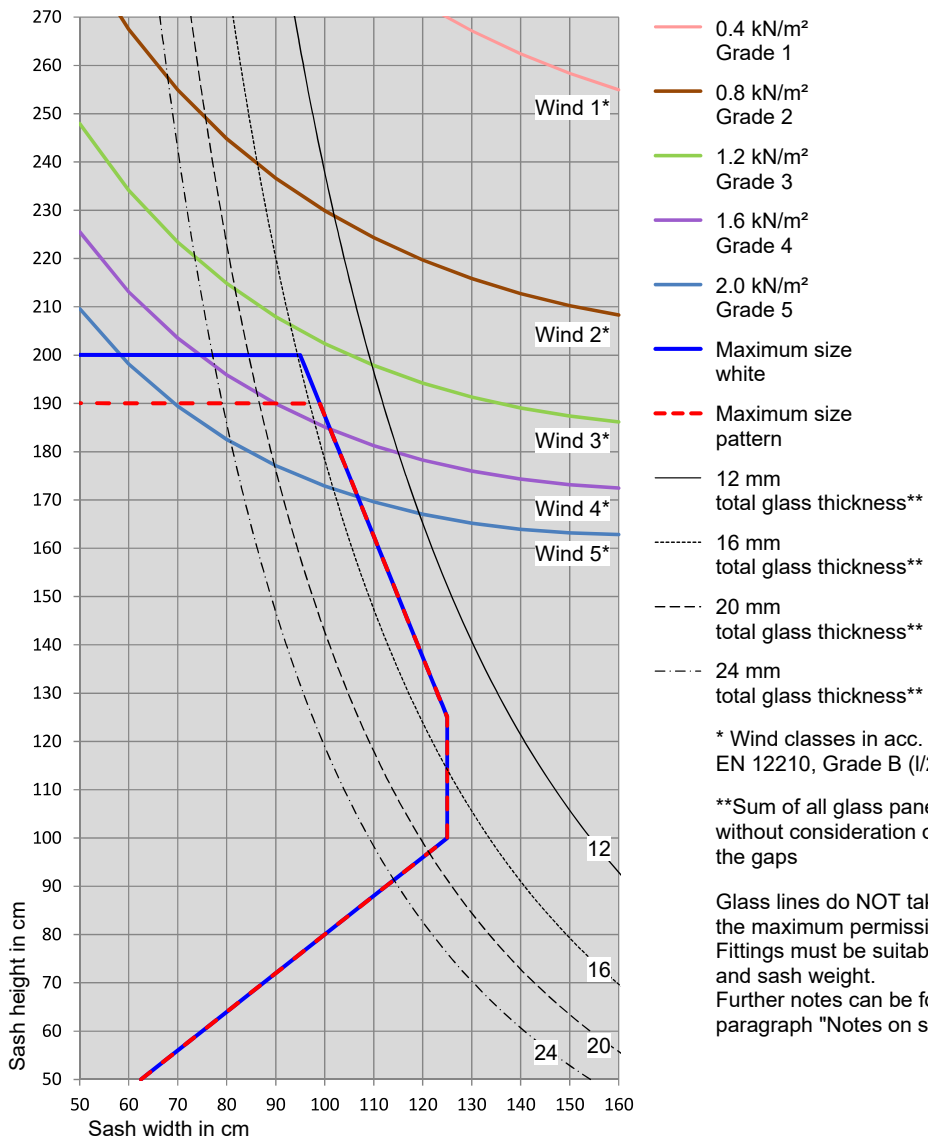
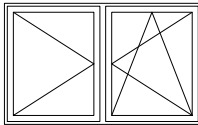

Turn-only / Tilt&Turn sash

**VS8050-74**

Size chart for strengthening VS8050, 2.0 mm - single sash

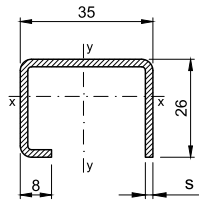

VS8050-74  
Thickness  
2.0 mm  
 $I_x = 1.40 \text{ cm}^4$   
 $I_y = 3.41 \text{ cm}^4$

Application for sashes



HO8520



HO8521



HP8920

Window type 1.1 Turn-only / bottom-hung window/door

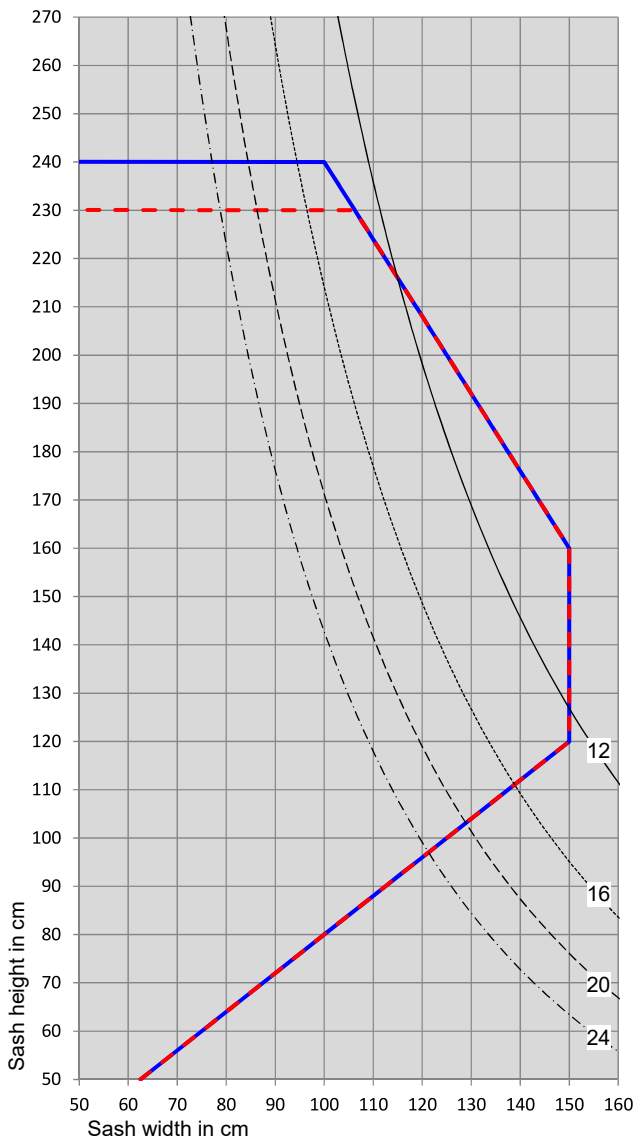
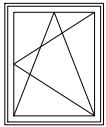

- Maximum size white
- - - Maximum size pattern
- 12 mm total glass thickness\*\*
- ..... 16 mm total glass thickness\*\*
- - - 20 mm total glass thickness\*\*
- - - 24 mm total glass thickness\*\*

\*\*Sum of all glass panes without consideration of the gaps

Glass lines do NOT take into account the maximum permissible sash weight. Fittings must be suitable for sash size and sash weight. Further notes can be found in paragraph "Notes on sash sizes".

Turn-only / Tilt&Turn sash

**VS8050-74**

Size chart for strengthening VS8050, 2.0 mm - single sash

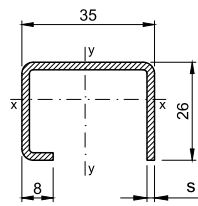

**VS8050-74**  
 Thickness  
 2.0 mm  
 $lx = 1.40 \text{ cm}^4$   
 $ly = 3.41 \text{ cm}^4$

Application for sashes

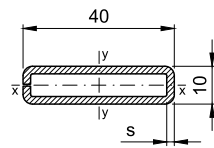
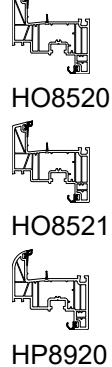

**VS9810-74**  
 Thickness  
 2.0 mm  
 $lx = 0.26 \text{ cm}^4$   
 $ly = 2.77 \text{ cm}^4$

Application for faceplate



Window type 1.2 Turn-only / bottom-hung window/door

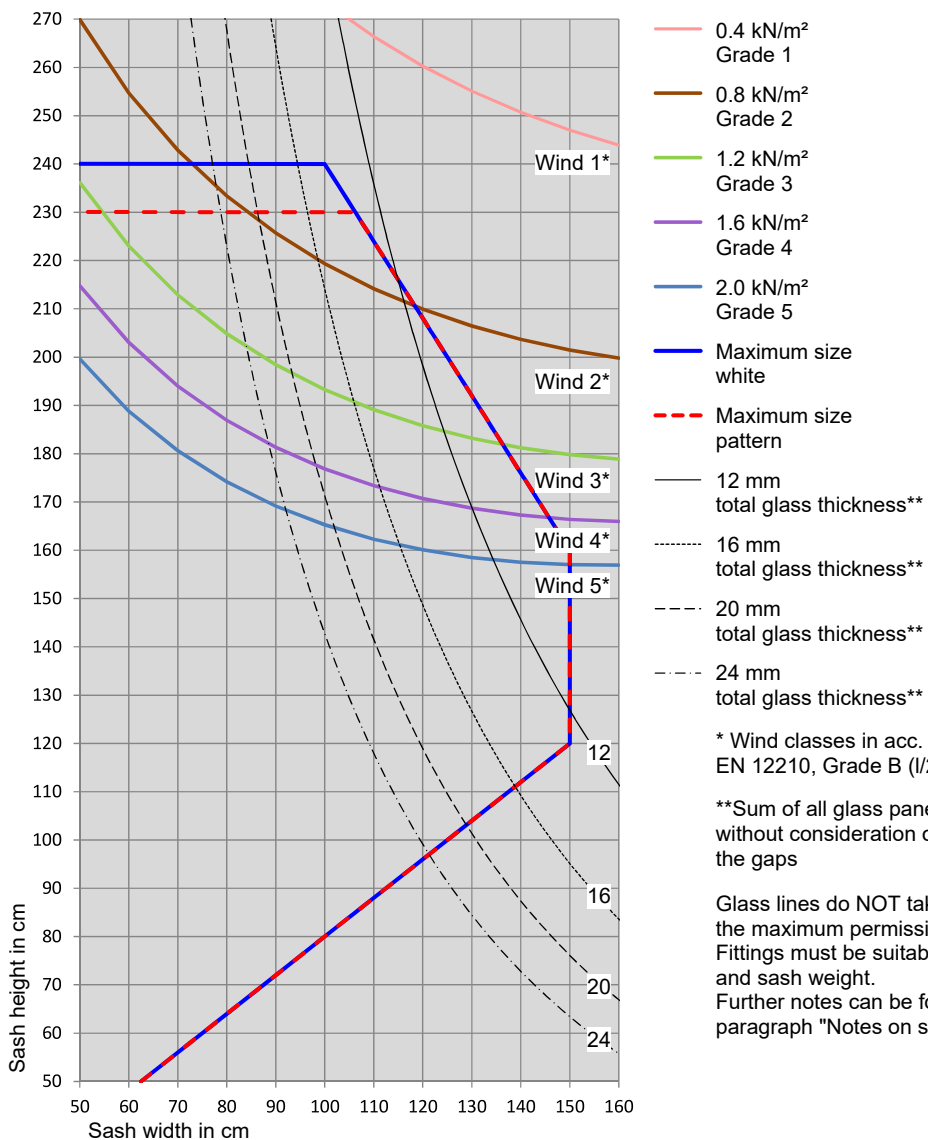
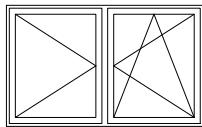

Turn-only / Tilt&Turn sash

**VS8050-74**

Size chart for strengthening VS8050, 2.0 mm - French window sash with wide faceplate

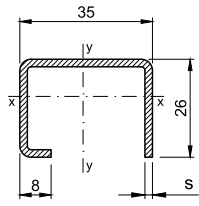

**VS8050-74**  
 Thickness  
 2.0 mm  
 $I_x = 1.40 \text{ cm}^4$   
 $I_y = 3.41 \text{ cm}^4$

Application for sashes



HO8520



HO8521



HP8920

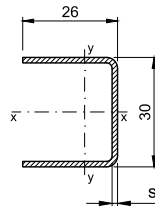

**VS8020-73**  
 Thickness  
 1.5 mm  
 $I_x = 1.77 \text{ cm}^4$   
 $I_y = 0.82 \text{ cm}^4$

Application for faceplate



HO9800



HO9850



HO8800

Window type 1.2 Turn-only / bottom-hung window/door

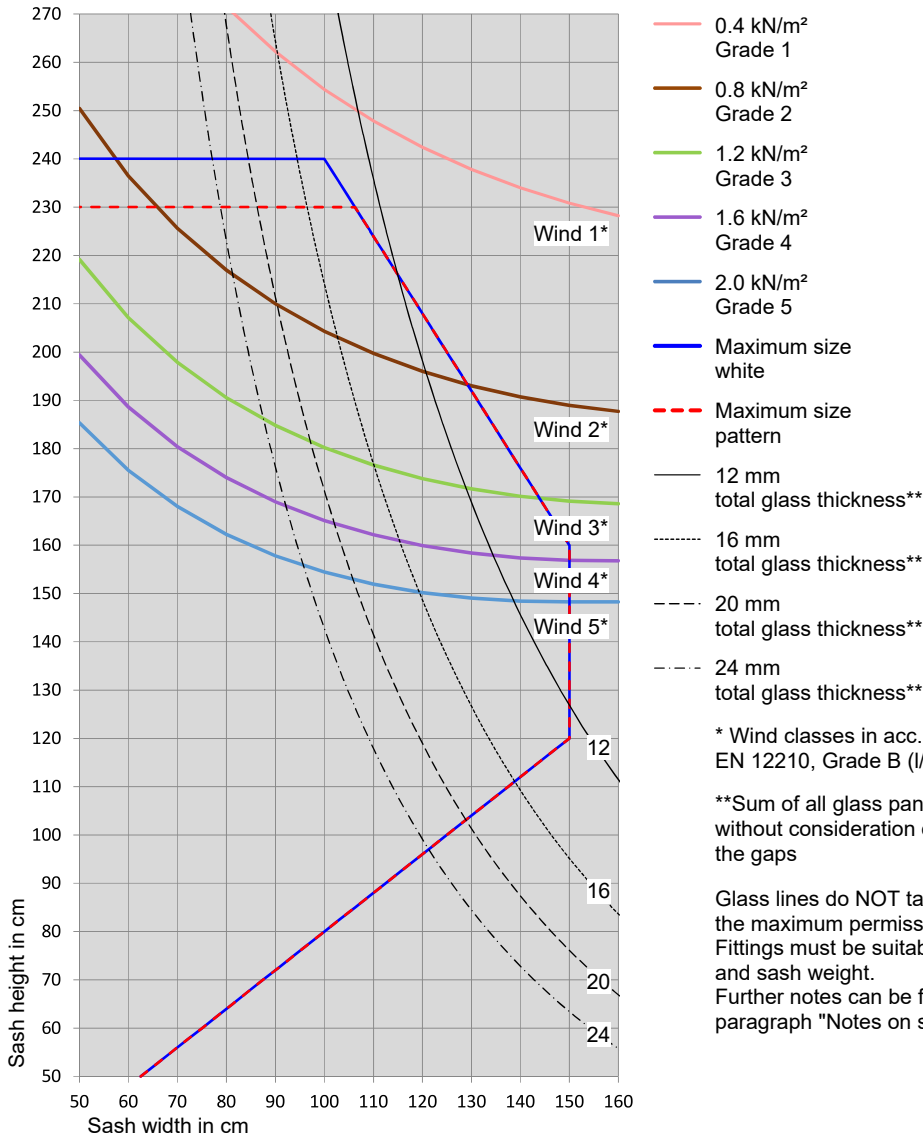
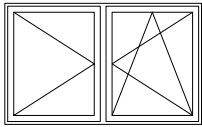

Turn-only / Tilt&Turn sash

**VS8050-74**

Size chart for strengthening VS8050, 2.0 mm - French window sash with wide faceplate

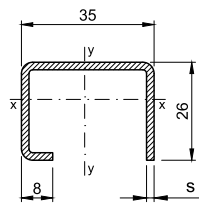

**VS8050-74**  
 Thickness  
 2.0 mm  
 $I_x = 1.40 \text{ cm}^4$   
 $I_y = 3.41 \text{ cm}^4$

Application for sashes

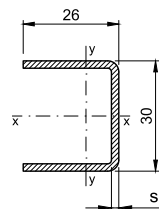
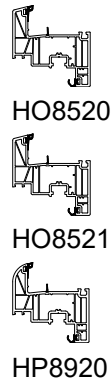

**VS8020-74**  
 Thickness  
 2.0 mm  
 $I_x = 2.26 \text{ cm}^4$   
 $I_y = 1.06 \text{ cm}^4$

Application for faceplate

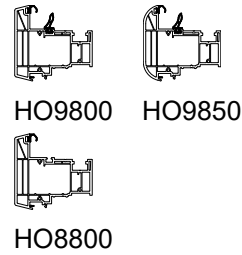

Window type 1.2 Turn-only / bottom-hung window/door

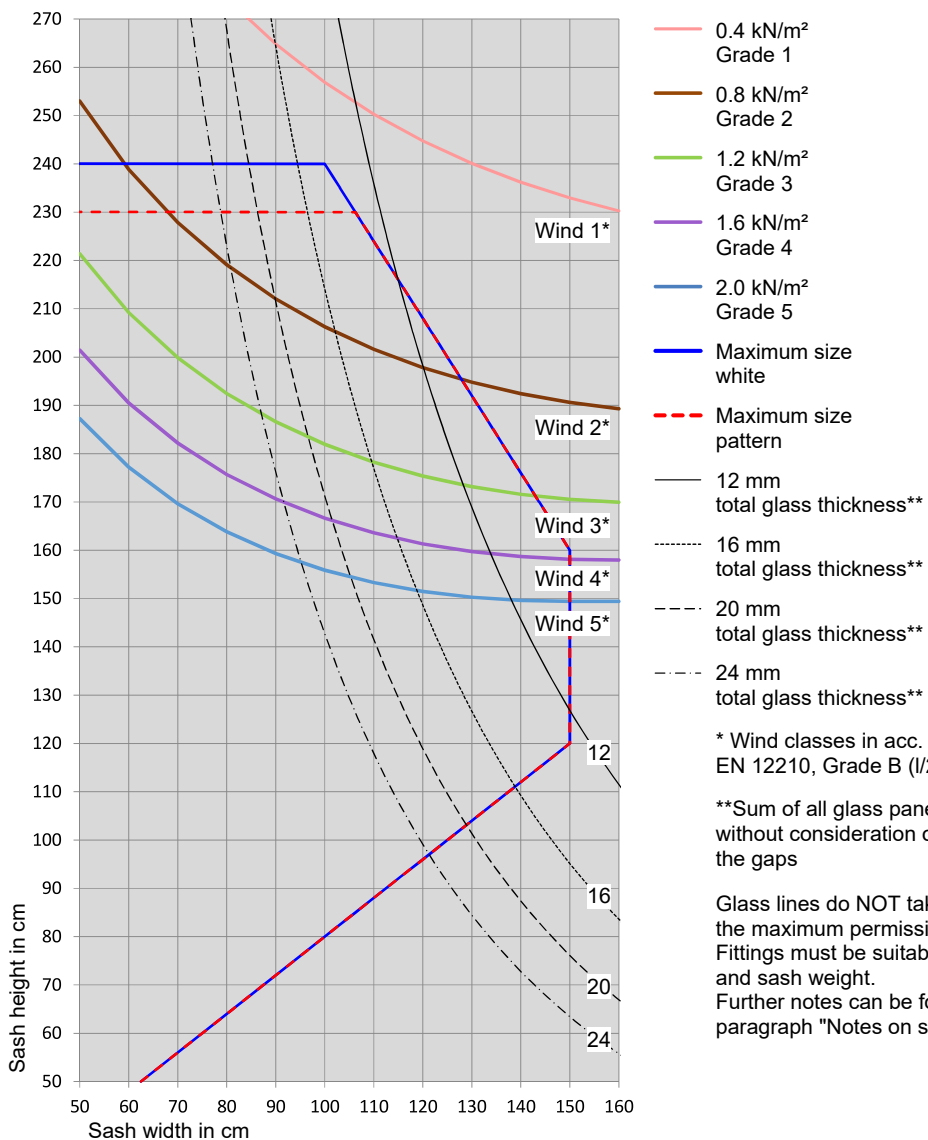
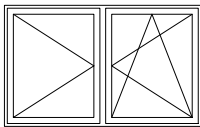

- 0.4 kN/m<sup>2</sup> Grade 1
- 0.8 kN/m<sup>2</sup> Grade 2
- 1.2 kN/m<sup>2</sup> Grade 3
- 1.6 kN/m<sup>2</sup> Grade 4
- 2.0 kN/m<sup>2</sup> Grade 5
- Maximum size white
- - - Maximum size pattern
- 12 mm total glass thickness\*\*
- · - · - 16 mm total glass thickness\*\*
- - - - 20 mm total glass thickness\*\*
- · - · - 24 mm total glass thickness\*\*

\* Wind classes in acc. with EN 12210, Grade B (I/200)

\*\*Sum of all glass panes without consideration of the gaps

Glass lines do NOT take into account the maximum permissible sash weight. Fittings must be suitable for sash size and sash weight. Further notes can be found in paragraph "Notes on sash sizes".

Turn-only / Tilt&Turn sash

**VS8050-74**

Size chart for strengthening VS8050, 2.0 mm - French window sash with wide faceplate

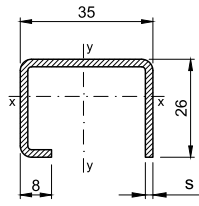

**VS8050-74**  
 Thickness  
 2.0 mm  
 $I_x = 1.40 \text{ cm}^4$   
 $I_y = 3.41 \text{ cm}^4$

Application for sashes

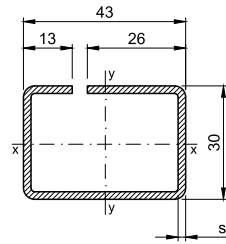
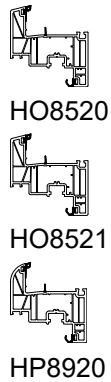

**VS9800-74**  
 Thickness  
 2.0 mm  
 $I_x = 3.65 \text{ cm}^4$   
 $I_y = 6.65 \text{ cm}^4$

Application for faceplate

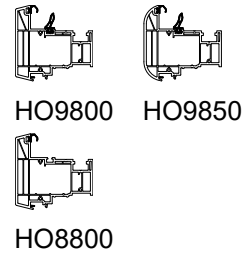

Window type 1.2 Turn-only / bottom-hung window/door

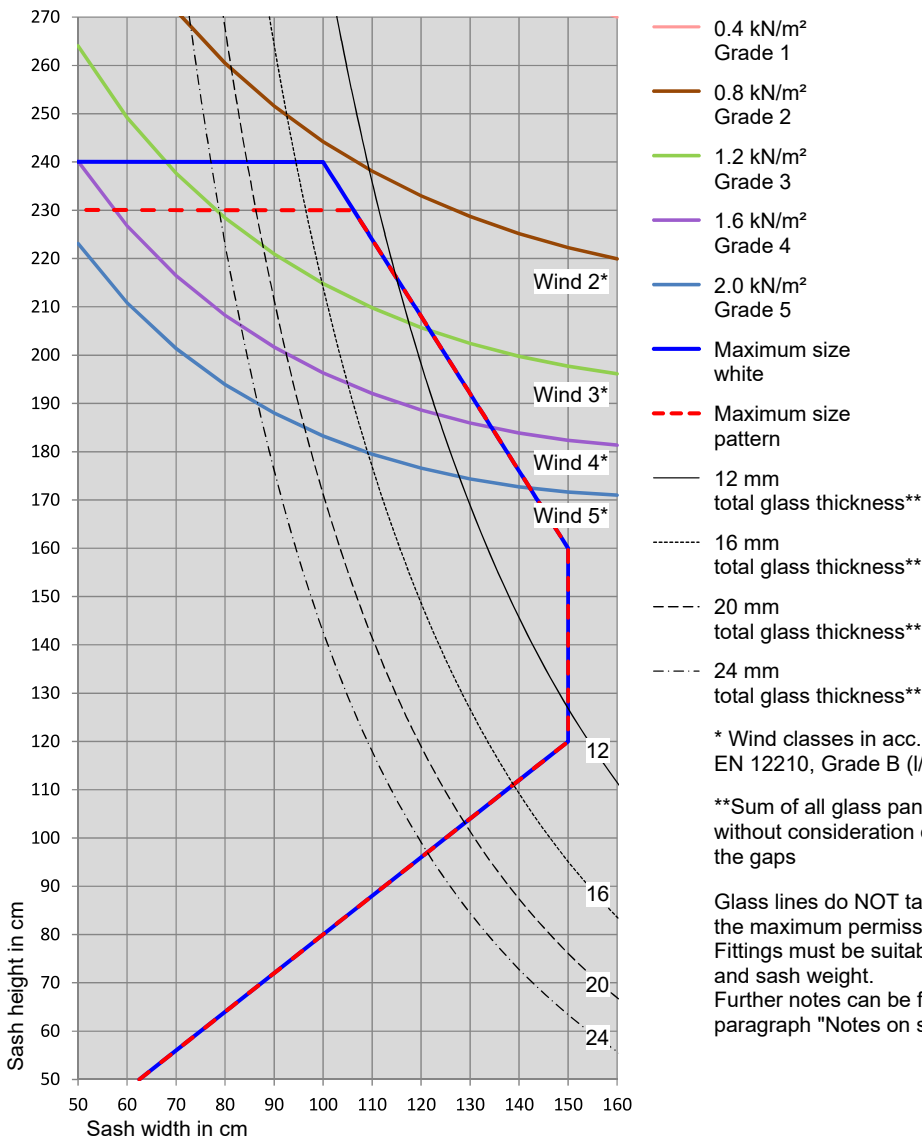
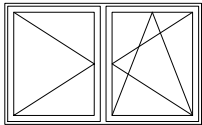

- 0.4 kN/m<sup>2</sup> Grade 1
- 0.8 kN/m<sup>2</sup> Grade 2
- 1.2 kN/m<sup>2</sup> Grade 3
- 1.6 kN/m<sup>2</sup> Grade 4
- 2.0 kN/m<sup>2</sup> Grade 5
- Maximum size white
- Maximum size pattern
- 12 mm total glass thickness\*\*
- 16 mm total glass thickness\*\*
- 20 mm total glass thickness\*\*
- 24 mm total glass thickness\*\*

\* Wind classes in acc. with EN 12210, Grade B (I/200)

\*\*Sum of all glass panes without consideration of the gaps

Glass lines do NOT take into account the maximum permissible sash weight. Fittings must be suitable for sash size and sash weight. Further notes can be found in paragraph "Notes on sash sizes".

Turn-only / Tilt&Turn sash

**VS8055-75**

Size chart for strengthening VS8055, 2.5 mm - single sash

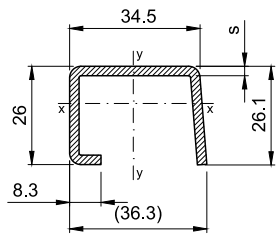

Application for sashes



HO8520



HO8521



HP8920

VS8055-75  
Thickness  
2.5 mm  
 $I_x = 1.65 \text{ cm}^4$   
 $I_y = 4.09 \text{ cm}^4$

Window type 1.1 Turn-only / bottom-hung window/door

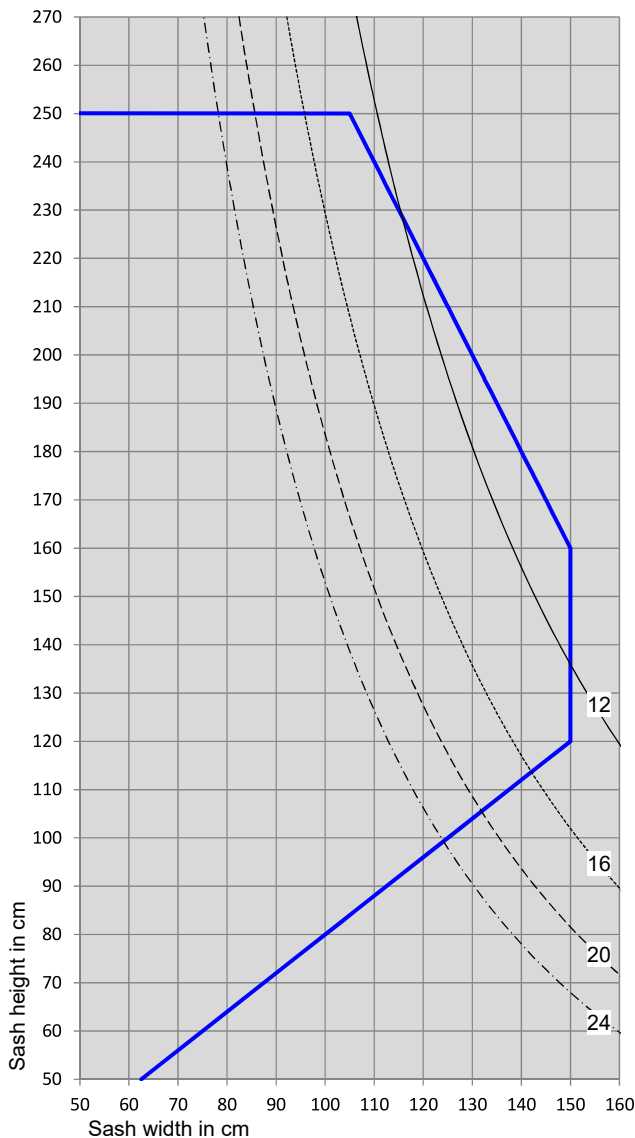
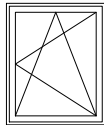

- Maximum size white
- - - Maximum size pattern
- 12 mm total glass thickness\*\*
- ..... 16 mm total glass thickness\*\*
- - - 20 mm total glass thickness\*\*
- . - . 24 mm total glass thickness\*\*

\*\*Sum of all glass panes without consideration of the gaps

Glass lines do NOT take into account the maximum permissible sash weight. Fittings must be suitable for sash size and sash weight. Further notes can be found in paragraph "Notes on sash sizes".

Turn-only / Tilt&Turn sash

**VS8055-75**

Size chart for strengthening VS8055, 2.5 mm - single sash

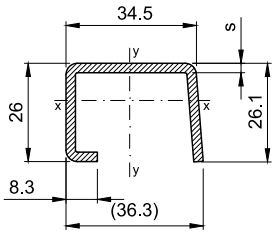

VS8055-75  
Thickness  
2.5 mm  
 $I_x = 1.65 \text{ cm}^4$   
 $I_y = 4.09 \text{ cm}^4$

Application for sashes

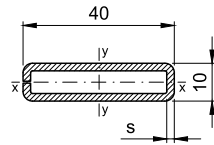
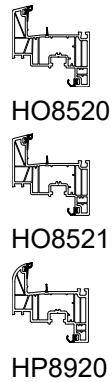

Application for faceplate

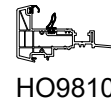

VS9810-74  
Thickness  
2.0 mm  
 $I_x = 0.26 \text{ cm}^4$   
 $I_y = 2.77 \text{ cm}^4$

Window type 1.2 Turn-only / bottom-hung window/door

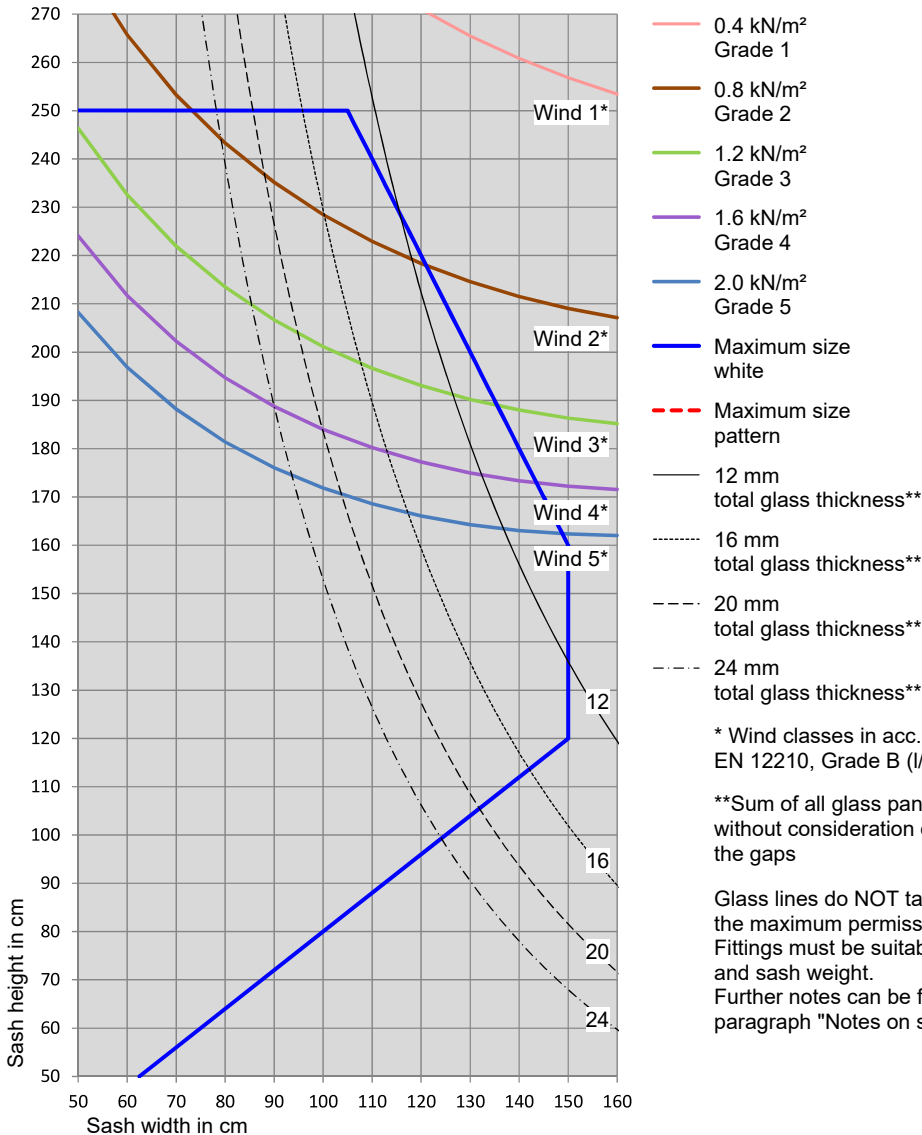
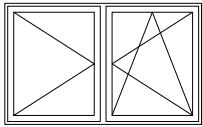

\* Wind classes in acc. with EN 12210, Grade B (I/200)

\*\*Sum of all glass panes without consideration of the gaps

Glass lines do NOT take into account the maximum permissible sash weight. Fittings must be suitable for sash size and sash weight. Further notes can be found in paragraph "Notes on sash sizes".

Turn-only / Tilt&Turn sash

**VS8055-75**

Size chart for strengthening VS8055, 2.5 mm - French window sash with wide faceplate

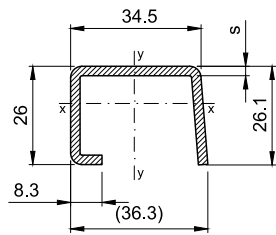

**VS8055-75**  
 Thickness  
 2.5 mm  
 $I_x = 1.65 \text{ cm}^4$   
 $I_y = 4.09 \text{ cm}^4$

Application for sashes

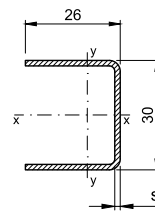
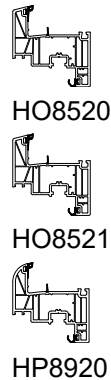

**VS8020-73**  
 Thickness  
 1.5 mm  
 $I_x = 1.77 \text{ cm}^4$   
 $I_y = 0.82 \text{ cm}^4$

Application for faceplate

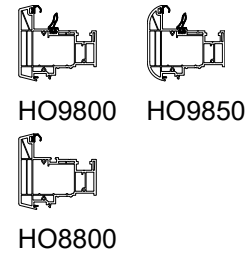

Window type 1.2 Turn-only / bottom-hung window/door

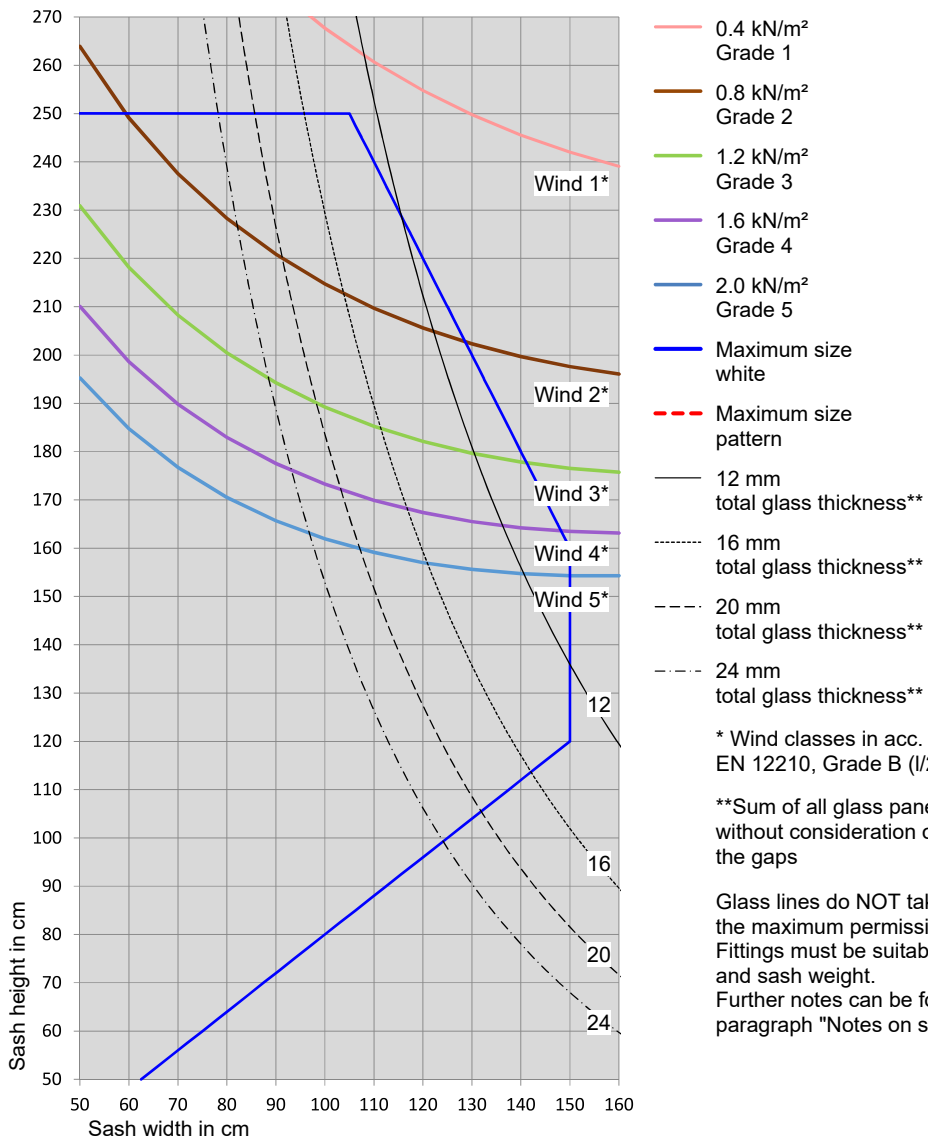
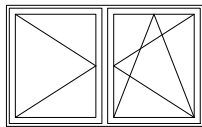

Turn-only / Tilt&Turn sash

**VS8055-75**

Size chart for strengthening VS8055, 2.5 mm - French window sash with wide faceplate

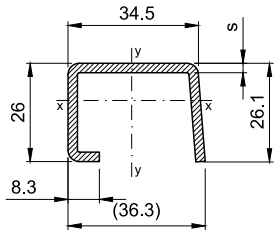

VS8055-75  
Thickness  
2.5 mm  
 $I_x = 1.65 \text{ cm}^4$   
 $I_y = 4.09 \text{ cm}^4$

Application for sashes

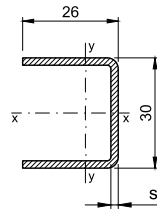
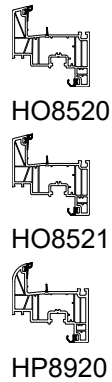

VS8020-74  
Thickness  
2.0 mm  
 $I_x = 2.26 \text{ cm}^4$   
 $I_y = 1.06 \text{ cm}^4$

Application for faceplate

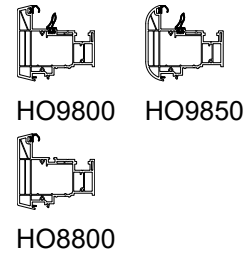

Window type 1.2 Turn-only / bottom-hung window/door

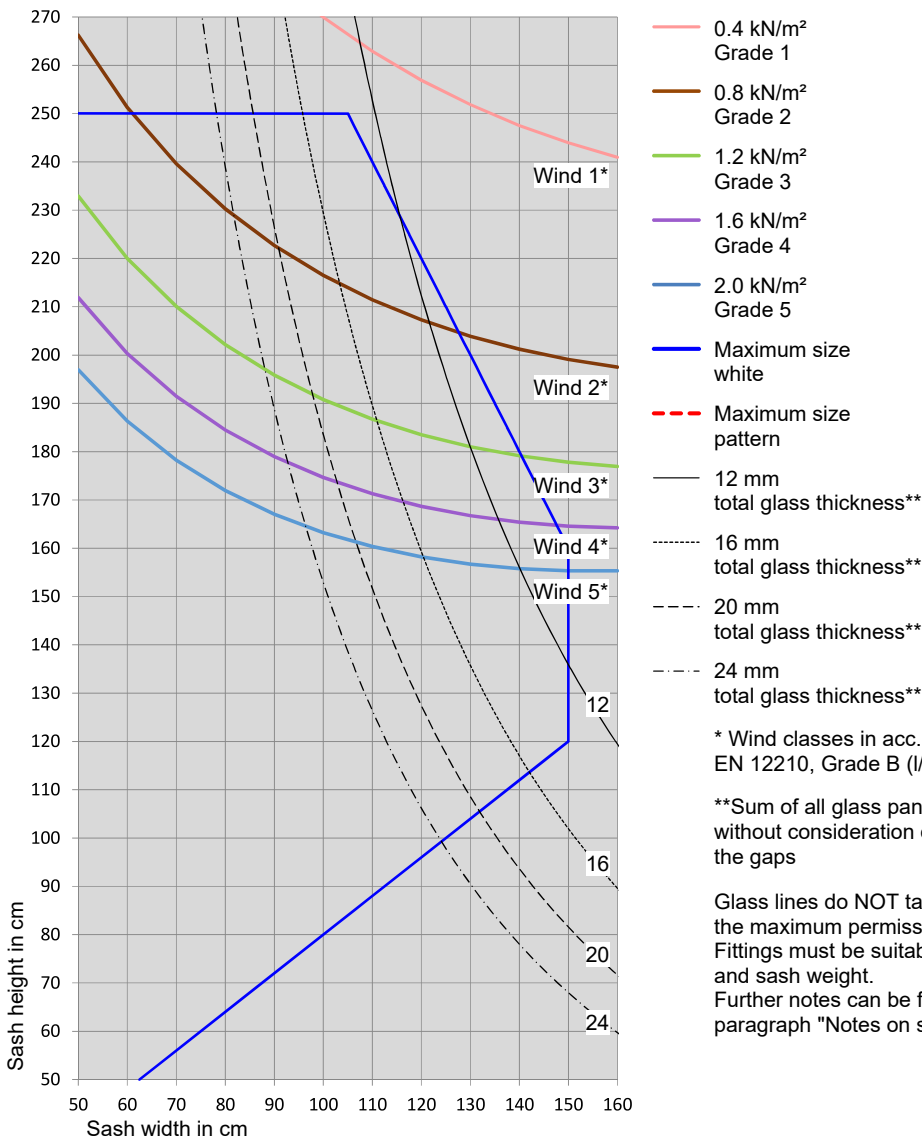
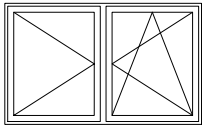

\* Wind classes in acc. with EN 12210, Grade B (I/200)

\*\*Sum of all glass panes without consideration of the gaps

Glass lines do NOT take into account the maximum permissible sash weight. Fittings must be suitable for sash size and sash weight. Further notes can be found in paragraph "Notes on sash sizes".

Turn-only / Tilt&Turn sash

**VS8055-75**

Size chart for strengthening VS8055, 2.5 mm - French window sash with wide faceplate

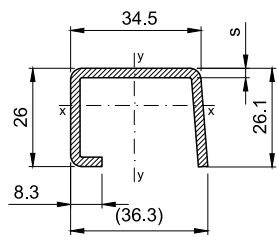

**VS8055-75**  
 Thickness  
 2.5 mm  
 $I_x = 1.65 \text{ cm}^4$   
 $I_y = 4.09 \text{ cm}^4$

Application for sashes

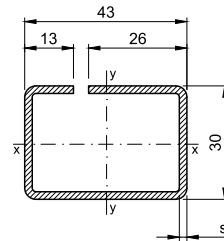

**VS9800-74**  
 Thickness  
 2.0 mm  
 $I_x = 3.65 \text{ cm}^4$   
 $I_y = 6.65 \text{ cm}^4$

Application for faceplate

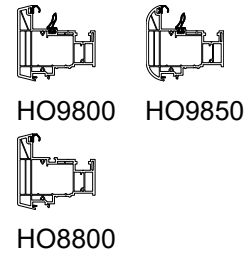

Window type 1.2 Turn-only / bottom-hung window/door

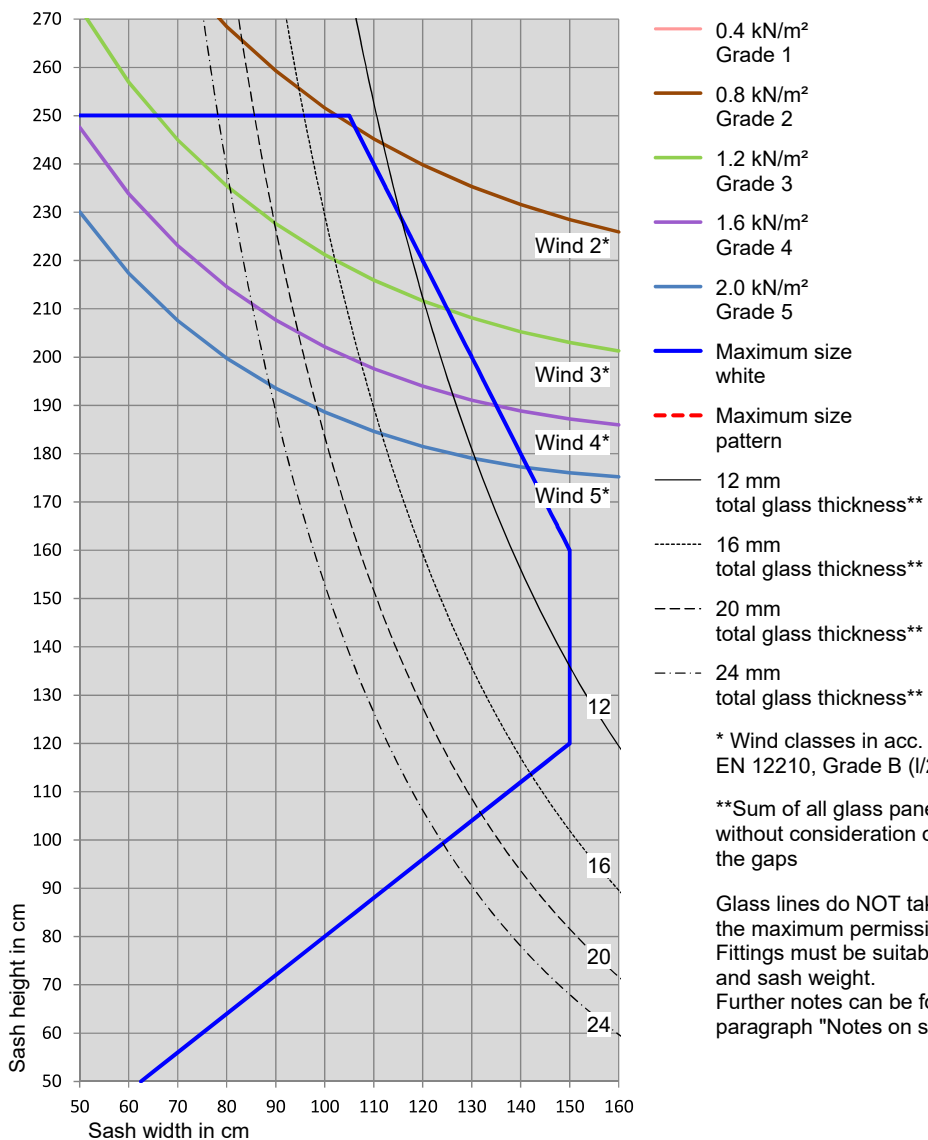
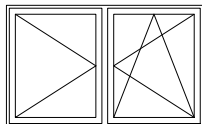

Turn-only / Tilt&Turn sash

**VS8520-73**

Size chart for strengthening VS8520, 1.5 mm - single sash

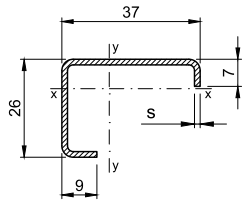

Application for sashes



HO8520



HO8521



HP8920

VS8520-73

Thickness

1.5 mm

$I_x = 0.89 \text{ cm}^4$

$I_y = 1.72 \text{ cm}^4$

Window type 1.1 Turn-only / bottom-hung window/door

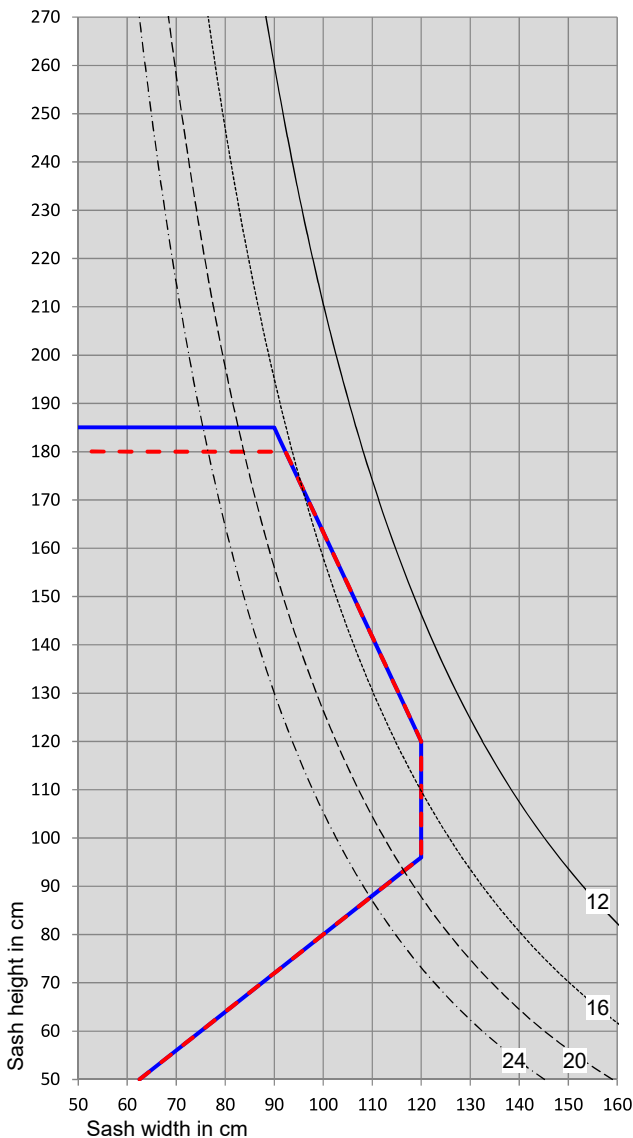
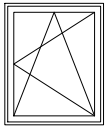

- Maximum size white
- - - Maximum size pattern
- 12 mm total glass thickness\*\*
- ..... 16 mm total glass thickness\*\*
- - - 20 mm total glass thickness\*\*
- · - · 24 mm total glass thickness\*\*

\*\*Sum of all glass panes without consideration of the gaps

Glass lines do NOT take into account the maximum permissible sash weight. Fittings must be suitable for sash size and sash weight. Further notes can be found in paragraph "Notes on sash sizes".

Turn-only / Tilt&Turn sash

**VS8520-73**

Size chart for strengthening VS8520, 1.5 mm - single sash

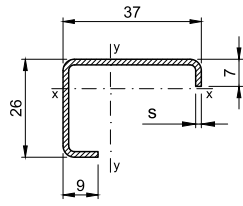

**VS8520-73**  
 Thickness  
 1.5 mm  
 $I_x = 0.89 \text{ cm}^4$   
 $I_y = 1.72 \text{ cm}^4$

Application for sashes

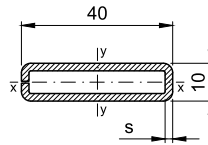
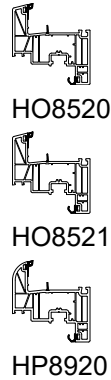

**VS9810-74**  
 Thickness  
 2.0 mm  
 $I_x = 0.26 \text{ cm}^4$   
 $I_y = 2.77 \text{ cm}^4$

Application for faceplate

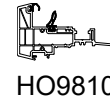

Window type 1.2 Turn-only / bottom-hung window/door

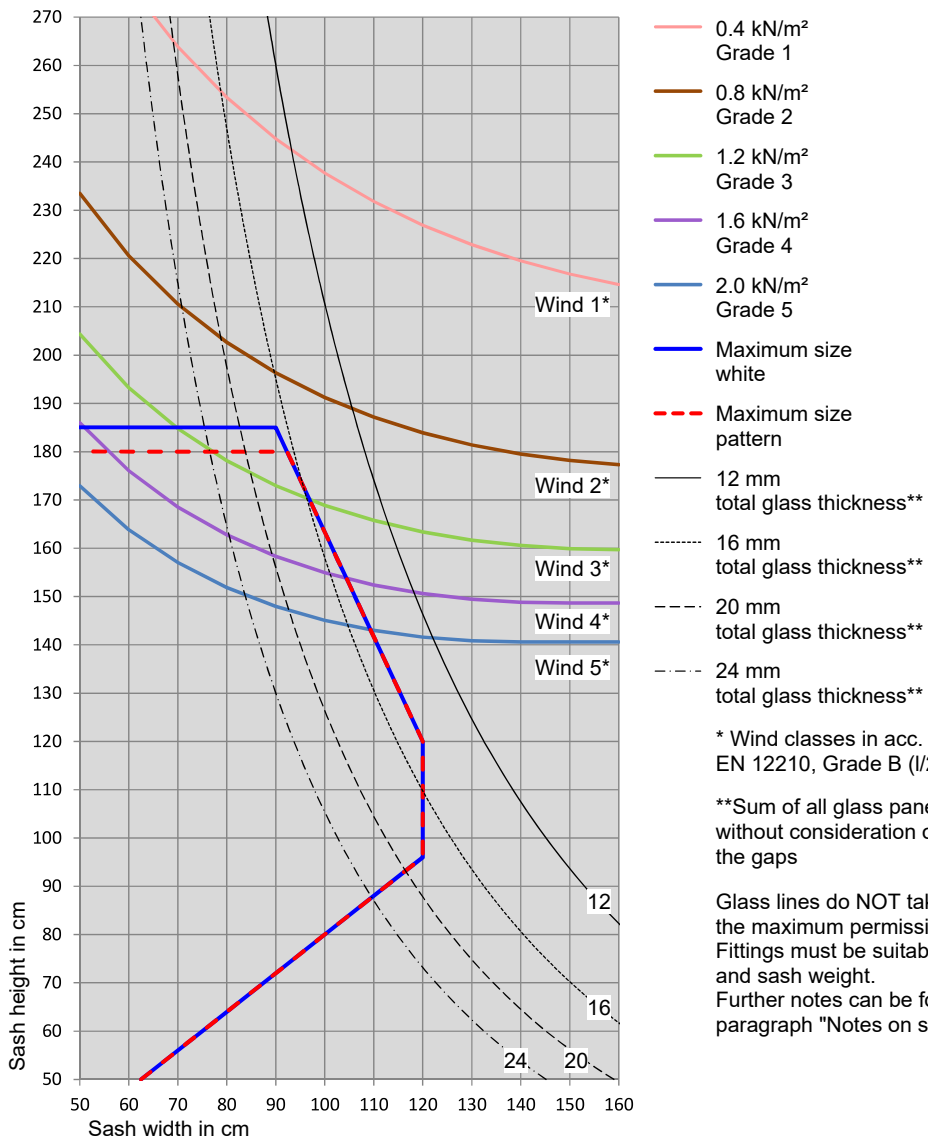
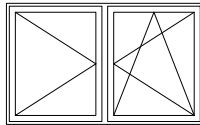

Turn-only / Tilt&Turn sash

**VS8520-73**

Size chart for strengthening VS8520, 1.5 mm - French window sash with wide faceplate

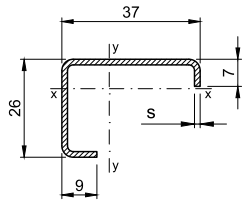

VS8520-73  
Thickness  
1.5 mm  
 $I_x = 0.89 \text{ cm}^4$   
 $I_y = 1.72 \text{ cm}^4$

Application for sashes

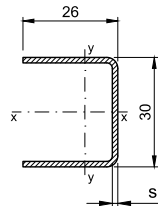
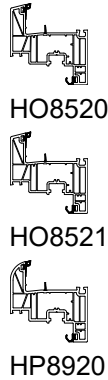

VS8020-73  
Thickness  
1.5 mm  
 $I_x = 1.77 \text{ cm}^4$   
 $I_y = 0.82 \text{ cm}^4$

Application for faceplate

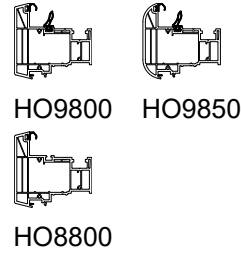

Window type 1.2 Turn-only / bottom-hung window/door

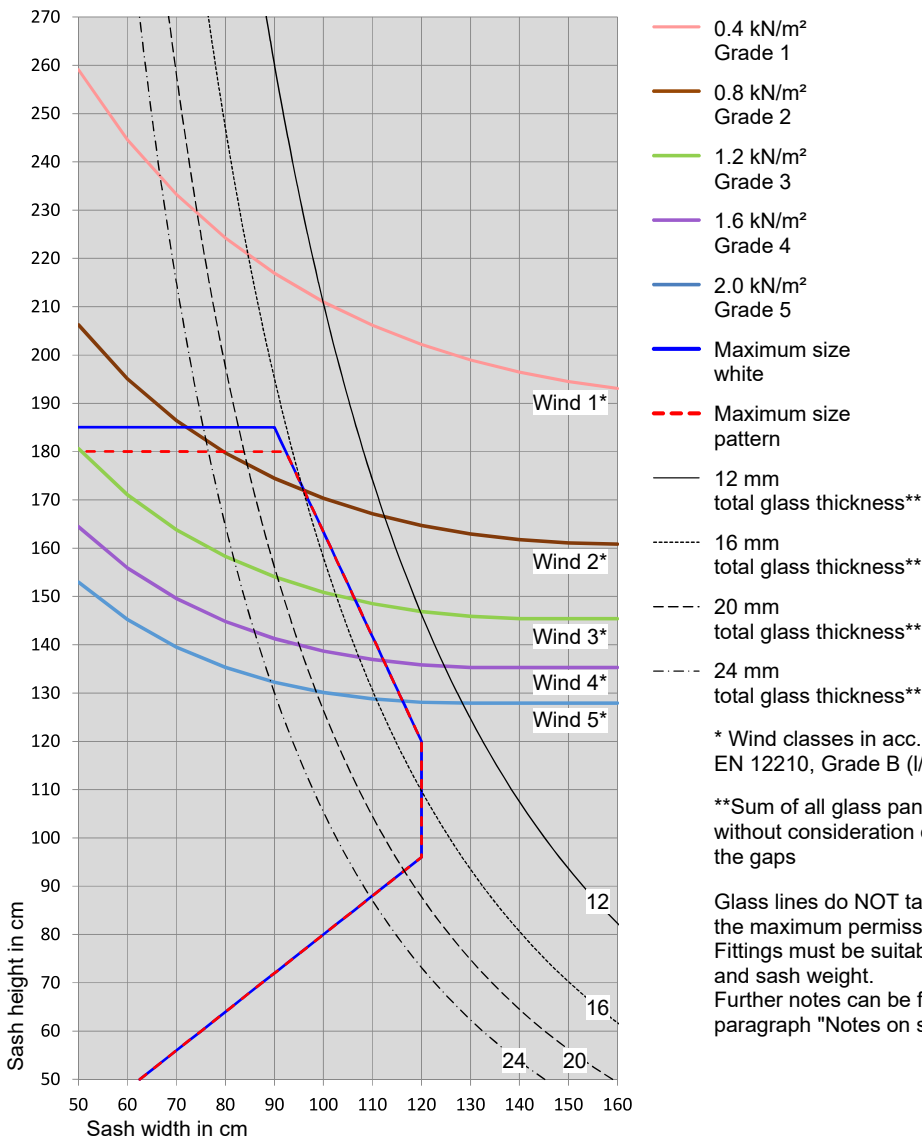
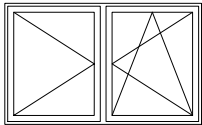

Turn-only / Tilt&Turn sash

**VS8520-73**

Size chart for strengthening VS8520, 1.5 mm - French window sash with wide faceplate

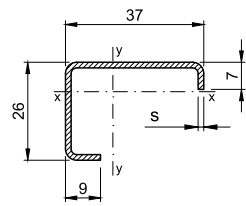

VS8520-73  
Thickness  
1.5 mm  
 $I_x = 0.89 \text{ cm}^4$   
 $I_y = 1.72 \text{ cm}^4$

Application for sashes

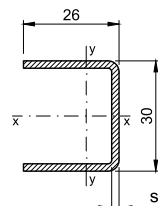
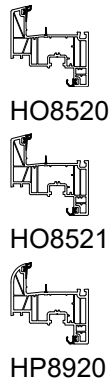

VS8020-74  
Thickness  
2.0 mm  
 $I_x = 2.26 \text{ cm}^4$   
 $I_y = 1.06 \text{ cm}^4$

Application for faceplate

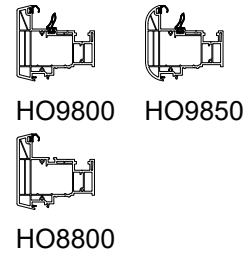

Window type 1.2 Turn-only / bottom-hung window/door

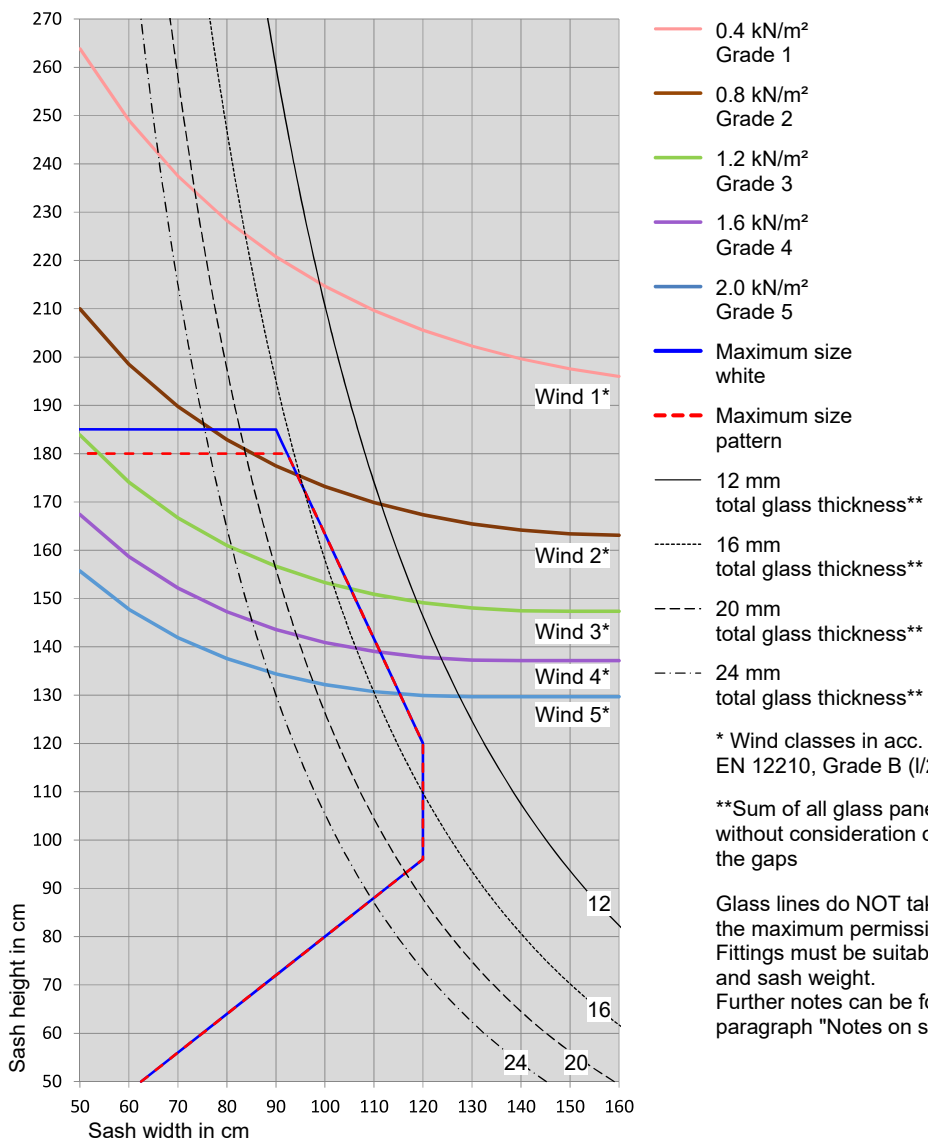
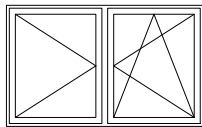

Turn-only / Tilt&Turn sash

**VS8520-73**

Size chart for strengthening VS8520, 1.5 mm - French window sash with wide faceplate

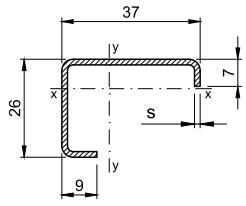

VS8520-73  
Thickness  
1.5 mm  
 $I_x = 0.89 \text{ cm}^4$   
 $I_y = 1.72 \text{ cm}^4$

Application for sashes

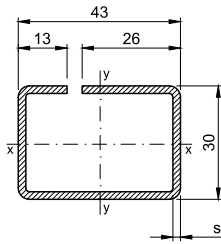
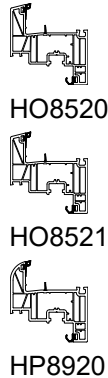

VS9800-74  
Thickness  
2.0 mm  
 $I_x = 3.65 \text{ cm}^4$   
 $I_y = 6.65 \text{ cm}^4$

Application for faceplate

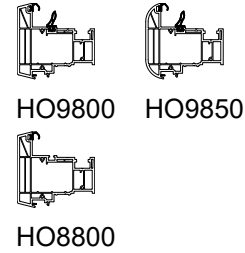

Window type 1.2 Turn-only / bottom-hung window/door

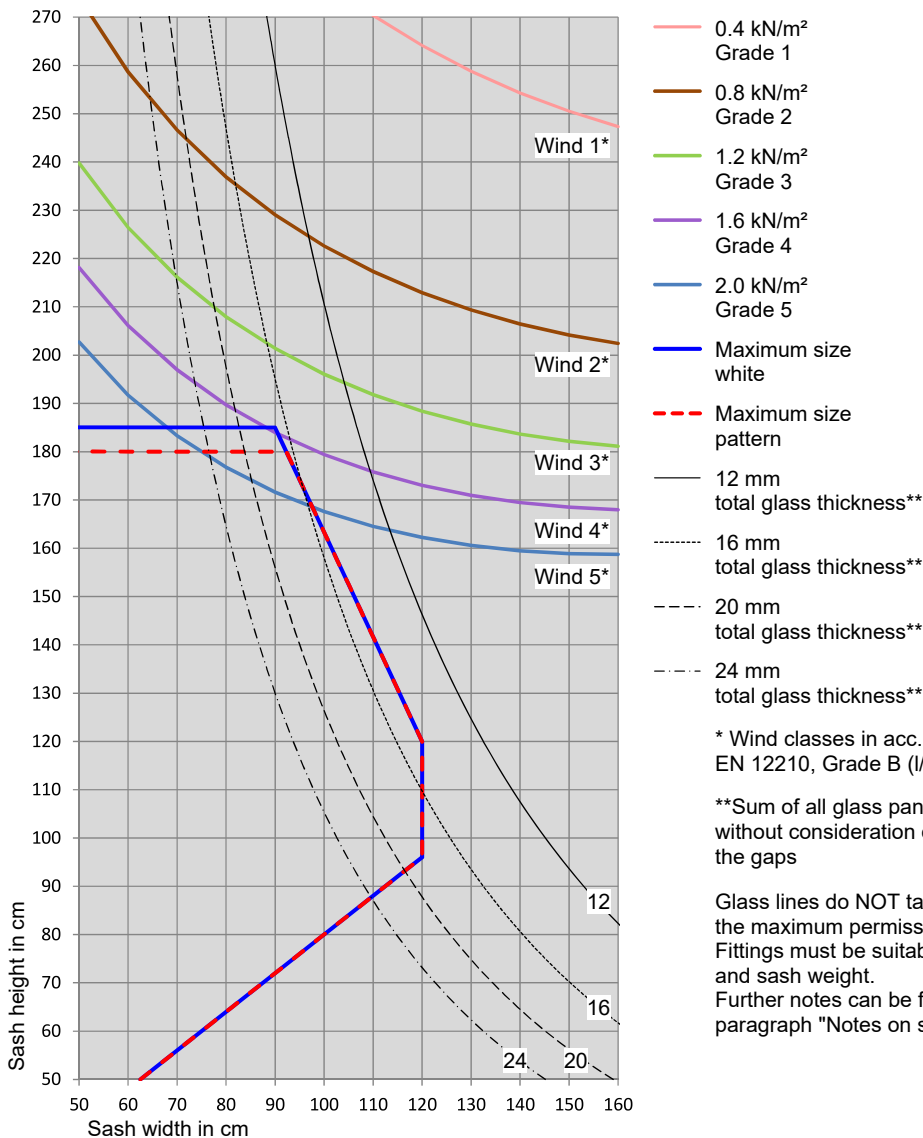
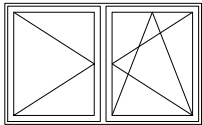

Turn-only / Tilt&Turn sash

**VS8620-74**

Size chart for strengthening VS8620, 2.0 mm - single sash

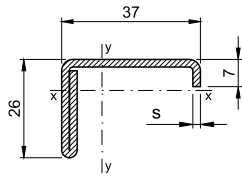

VS8620-74  
Thickness  
2.0 mm  
 $I_x = 1.11 \text{ cm}^4$   
 $I_y = 2.48 \text{ cm}^4$

Application for sashes



HO8520



HO8521



HP8920

Window type 1.1 Turn-only / bottom-hung window/door

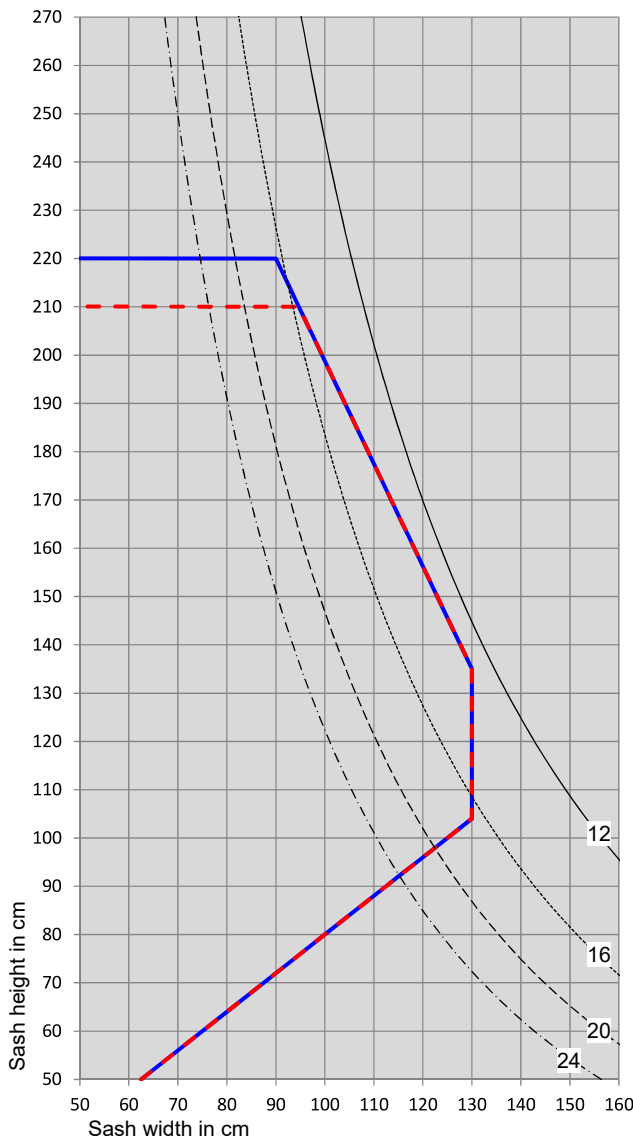
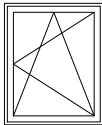

- Maximum size white
- - - Maximum size pattern
- 12 mm total glass thickness\*\*
- ..... 16 mm total glass thickness\*\*
- - - 20 mm total glass thickness\*\*
- . - . 24 mm total glass thickness\*\*

\*\*Sum of all glass panes without consideration of the gaps

Glass lines do NOT take into account the maximum permissible sash weight. Fittings must be suitable for sash size and sash weight. Further notes can be found in paragraph "Notes on sash sizes".

Turn-only / Tilt&Turn sash

**VS8620-74**

Size chart for strengthening VS8620, 2.0 mm - single sash

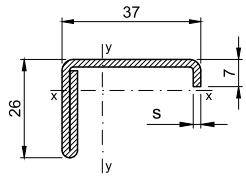

VS8620-74  
Thickness  
2.0 mm  
 $I_x = 1.11 \text{ cm}^4$   
 $I_y = 2.48 \text{ cm}^4$

Application for sashes



HO8520



HO8521



HP8920

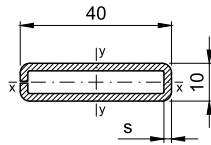

VS9810-74  
Thickness  
2.0 mm  
 $I_x = 0.26 \text{ cm}^4$   
 $I_y = 2.77 \text{ cm}^4$

Application for faceplate



HO9810

Window type 1.2 Turn-only / bottom-hung window/door

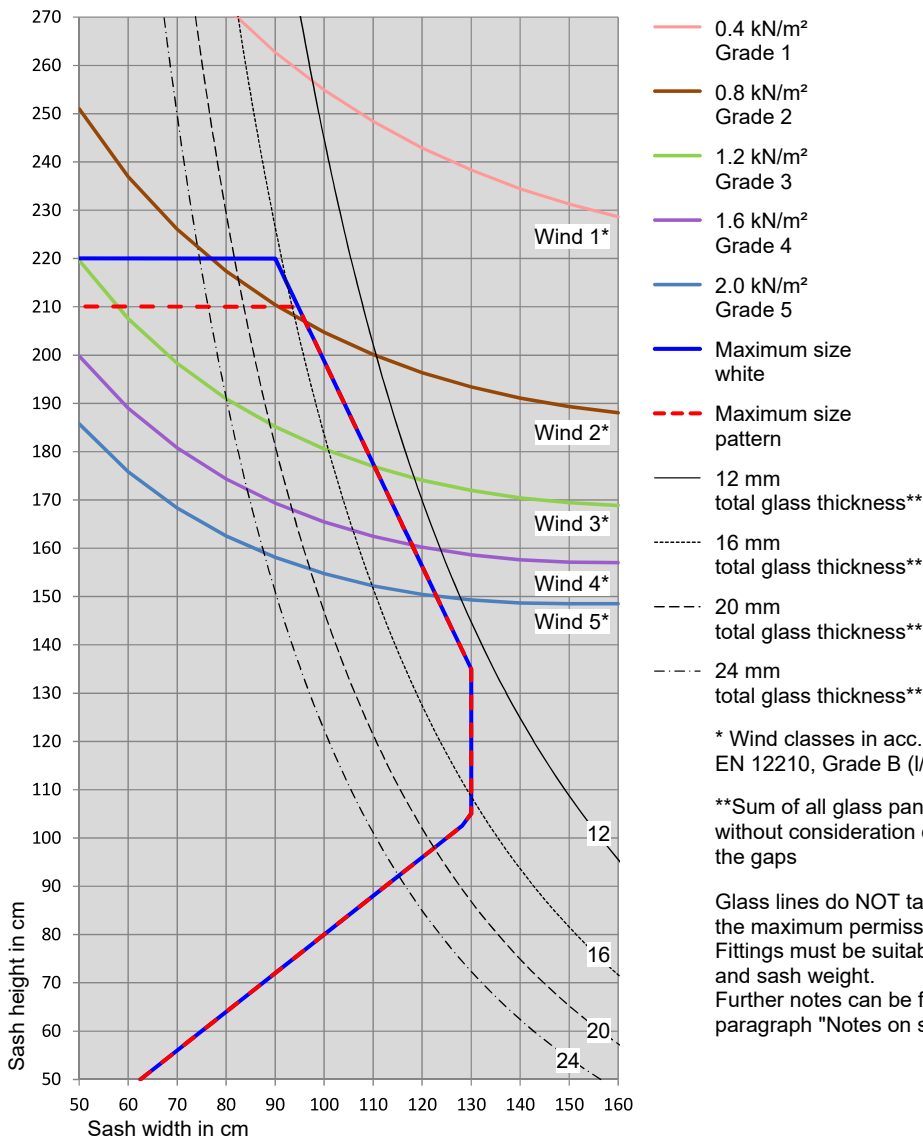
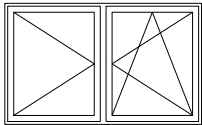

Turn-only / Tilt&Turn sash

**VS8620-74**

Size chart for strengthening VS8620, 2.0 mm - French window sash with wide faceplate

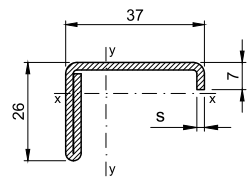

VS8620-74  
Thickness  
2.0 mm  
 $I_x = 1.11 \text{ cm}^4$   
 $I_y = 2.48 \text{ cm}^4$

Application for sashes

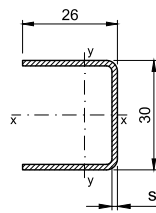
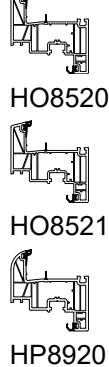

VS8020-73  
Thickness  
1.5 mm  
 $I_x = 1.77 \text{ cm}^4$   
 $I_y = 0.82 \text{ cm}^4$

Application for faceplate

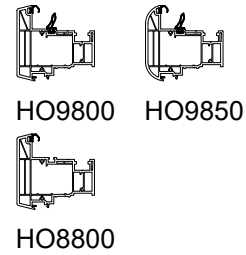

Window type 1.2 Turn-only / bottom-hung window/door

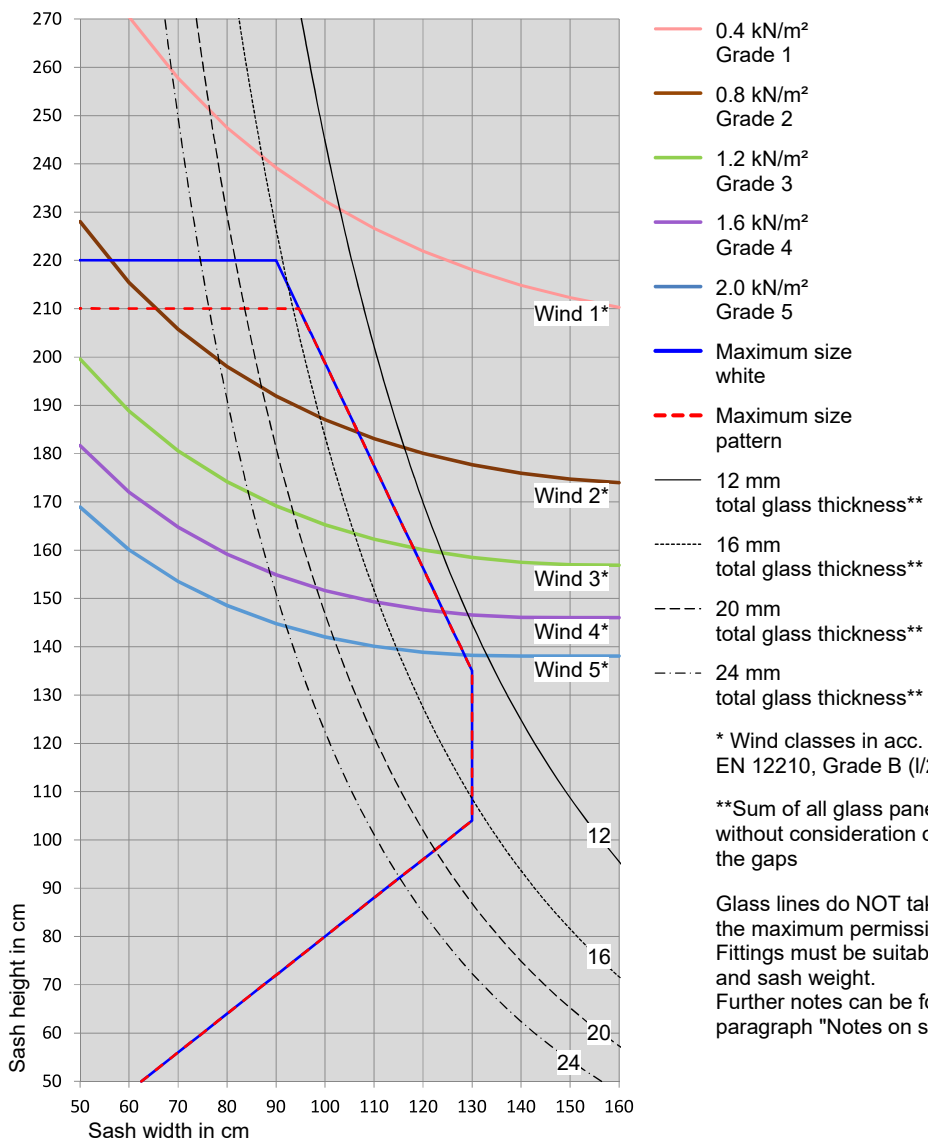
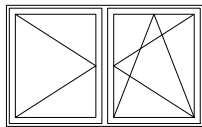

Turn-only / Tilt&Turn sash

**VS8620-74**

Size chart for strengthening VS8620, 2.0 mm - French window sash with wide faceplate

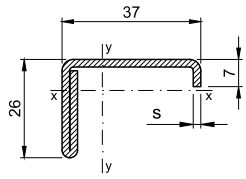

VS8620-74  
Thickness  
2.0 mm  
 $I_x = 1.11 \text{ cm}^4$   
 $I_y = 2.48 \text{ cm}^4$

Application for sashes

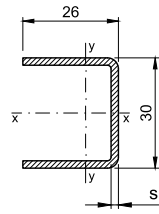
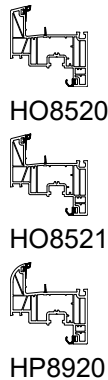

VS8020-74  
Thickness  
2.0 mm  
 $I_x = 2.26 \text{ cm}^4$   
 $I_y = 1.06 \text{ cm}^4$

Application for faceplate

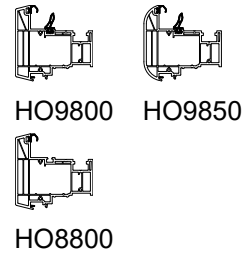

Window type 1.2 Turn-only / bottom-hung window/door

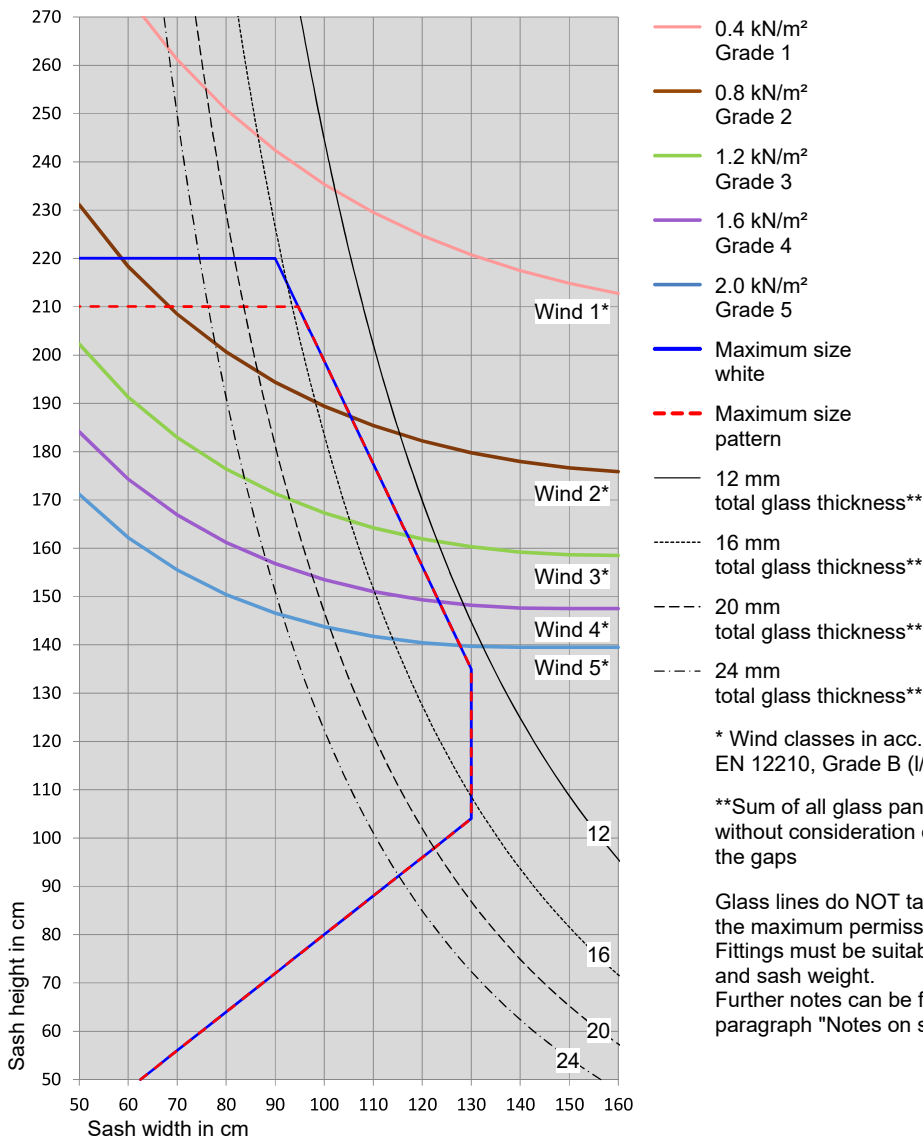
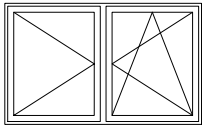

Turn-only / Tilt&Turn sash

**VS8620-74**

Size chart for strengthening VS8620, 2.0 mm - French window sash with wide faceplate

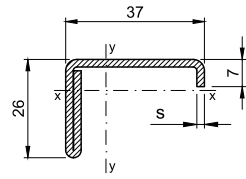

**VS8620-74**  
 Thickness  
 2.0 mm  
 $I_x = 1.11 \text{ cm}^4$   
 $I_y = 2.48 \text{ cm}^4$

Application for sashes

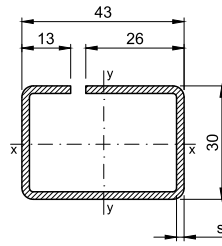
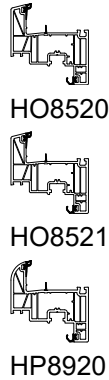

**VS9800-74**  
 Thickness  
 2.0 mm  
 $I_x = 3.65 \text{ cm}^4$   
 $I_y = 6.65 \text{ cm}^4$

Application for faceplate

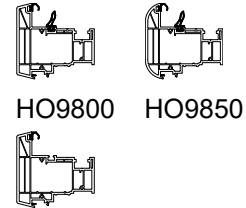

Window type 1.2 Turn-only / bottom-hung window/door

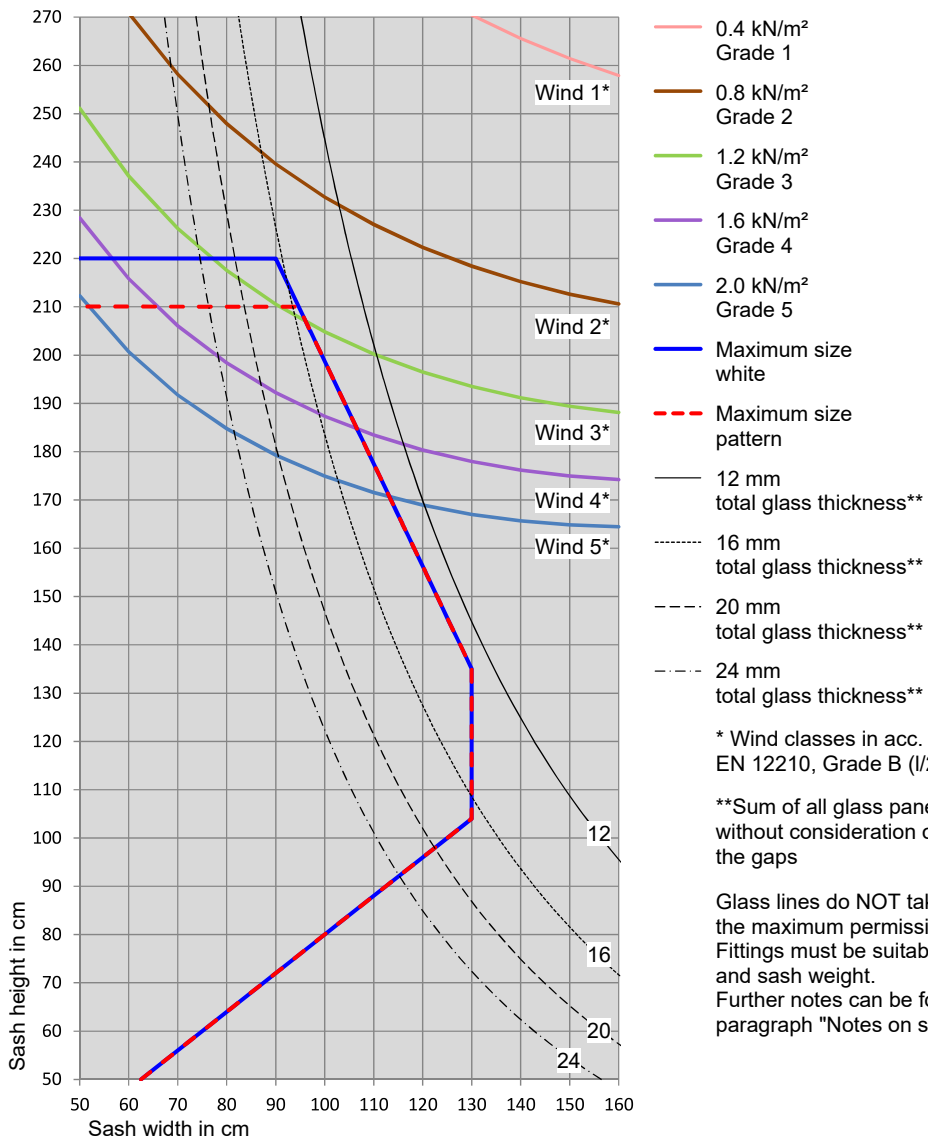
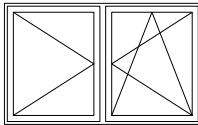

Turn-only / Tilt&Turn sash

**VS8030-73**

Size chart for strengthening VS8030, 1.5 mm - single sash

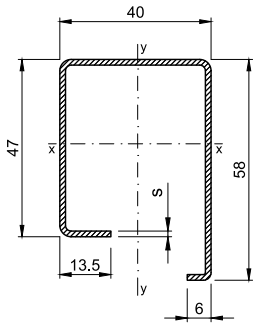

VS8030-73  
 Thickness 1.5 mm  
 $I_x = 8.36 \text{ cm}^4$   
 $I_y = 6.76 \text{ cm}^4$

Application for sashes

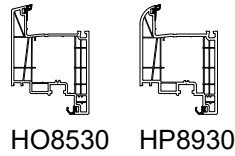

Window type 1.1 Turn-only / bottom-hung window/door

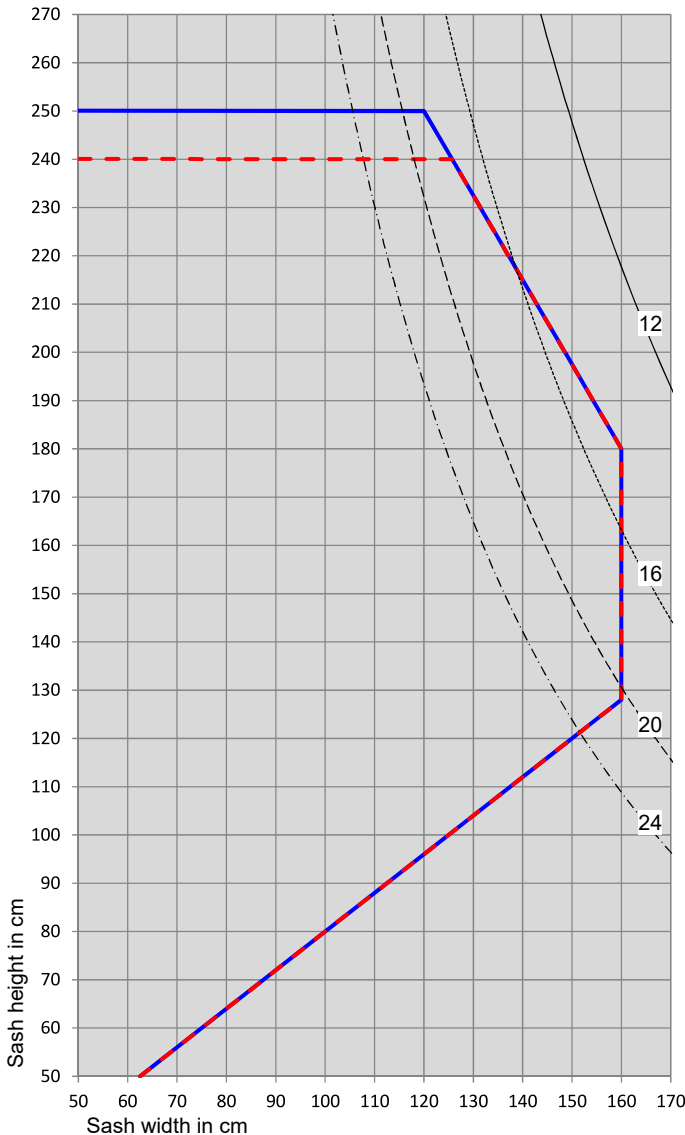
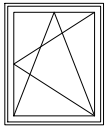

- Maximum size white
- - - Maximum size pattern
- 12 mm total glass thickness\*\*
- ..... 16 mm total glass thickness\*\*
- - - 20 mm total glass thickness\*\*
- . - . 24 mm total glass thickness\*\*

\*\*Sum of all glass panes without consideration of the gaps

Glass lines do NOT take into account the maximum permissible sash weight. Fittings must be suitable for sash size and sash weight. Further notes can be found in paragraph "Notes on sash sizes".

Turn-only / Tilt&Turn sash

**VS8030-73**

Size chart for strengthening VS8030, 1.5 mm - French window sash with wide faceplate

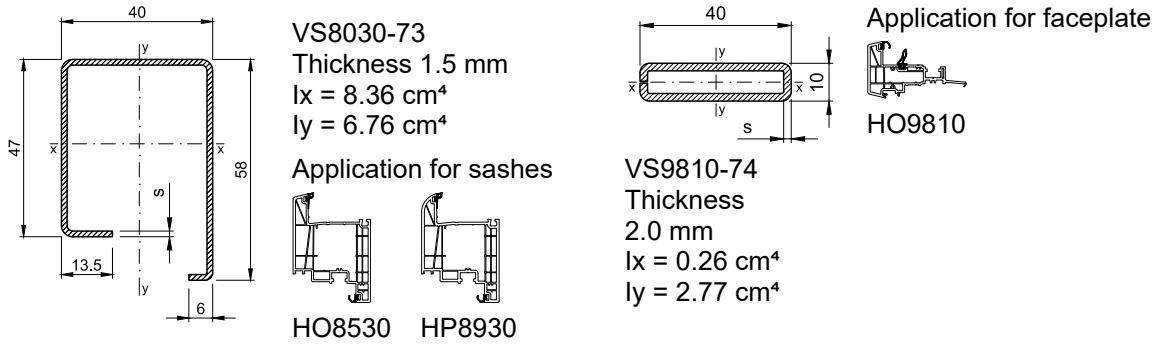

Window type 1.2 Turn-only / bottom-hung window/door

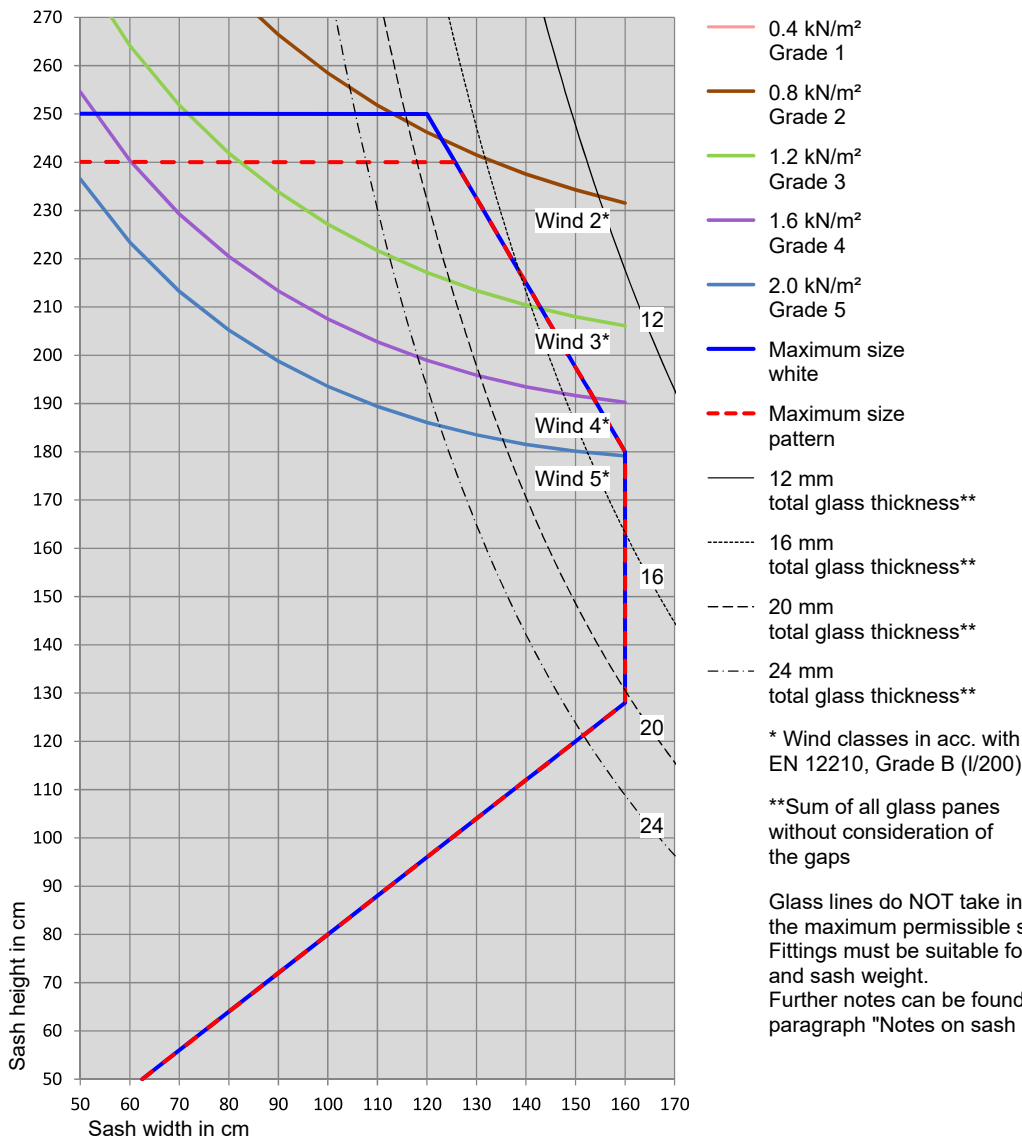
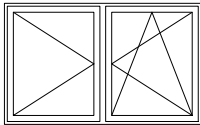

Turn-only / Tilt&Turn sash

**VS8030-73**

Size chart for strengthening VS8030, 1.5 mm - French window sash with wide faceplate

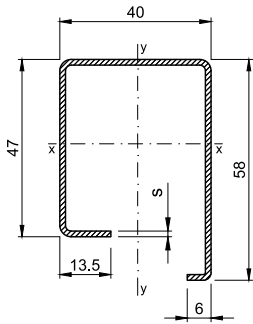

**VS8030-73**  
 Thickness 1.5 mm  
 $I_x = 8.36 \text{ cm}^4$   
 $I_y = 6.76 \text{ cm}^4$

Application for sashes

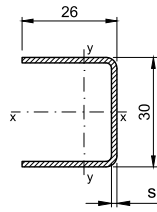
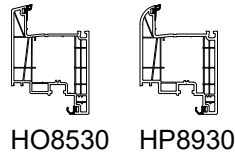

**VS8020-73**  
 Thickness 1.5 mm  
 $I_x = 1.77 \text{ cm}^4$   
 $I_y = 0.82 \text{ cm}^4$

Application for faceplate

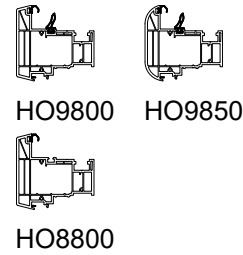

Window type 1.2 Turn-only / bottom-hung window/door

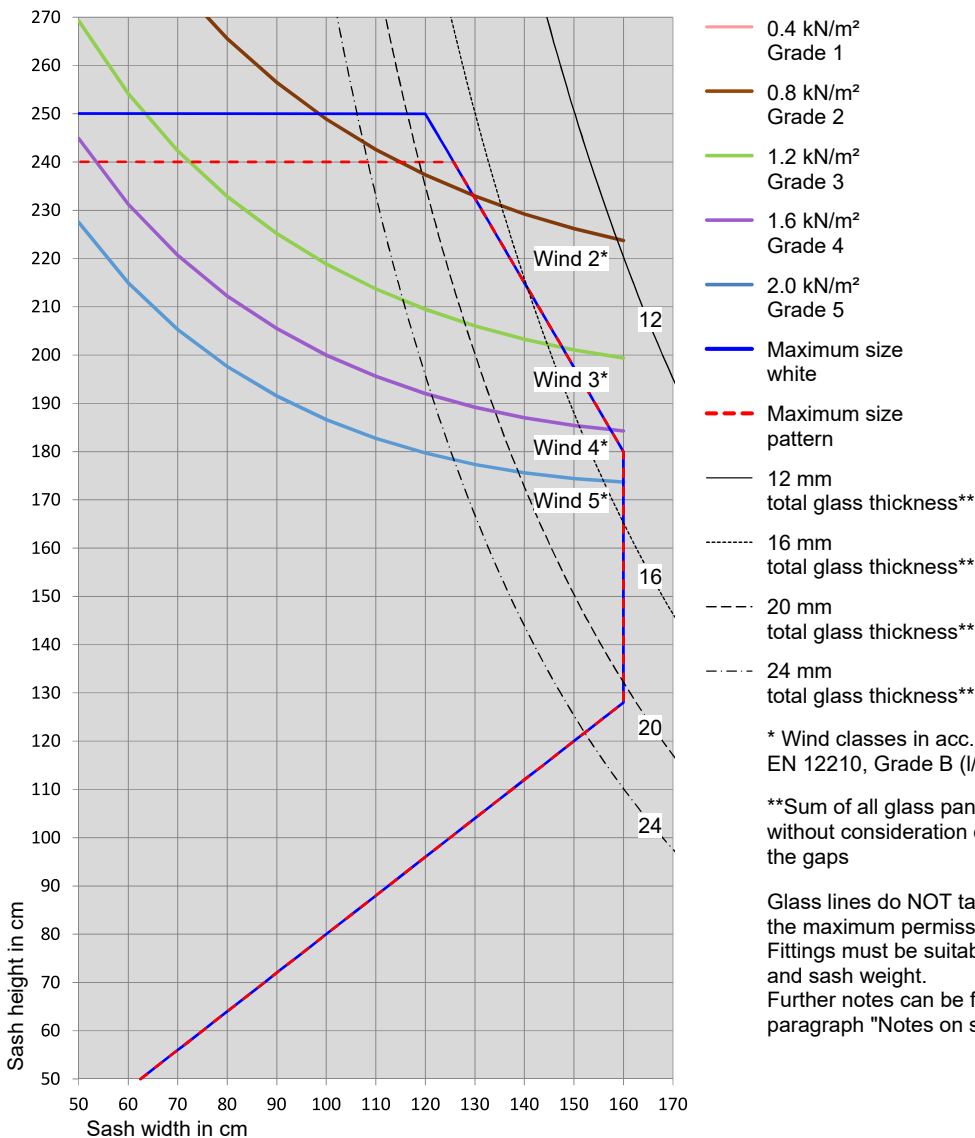
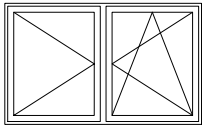

Turn-only / Tilt&Turn sash

**VS8030-73**

Size chart for strengthening VS8030, 1.5 mm - French window sash with wide faceplate

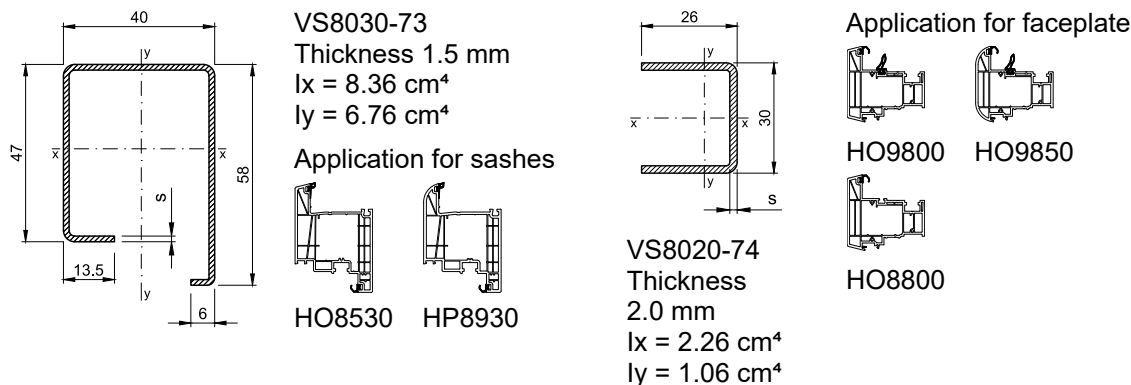

Window type 1.2 Turn-only / bottom-hung window/door

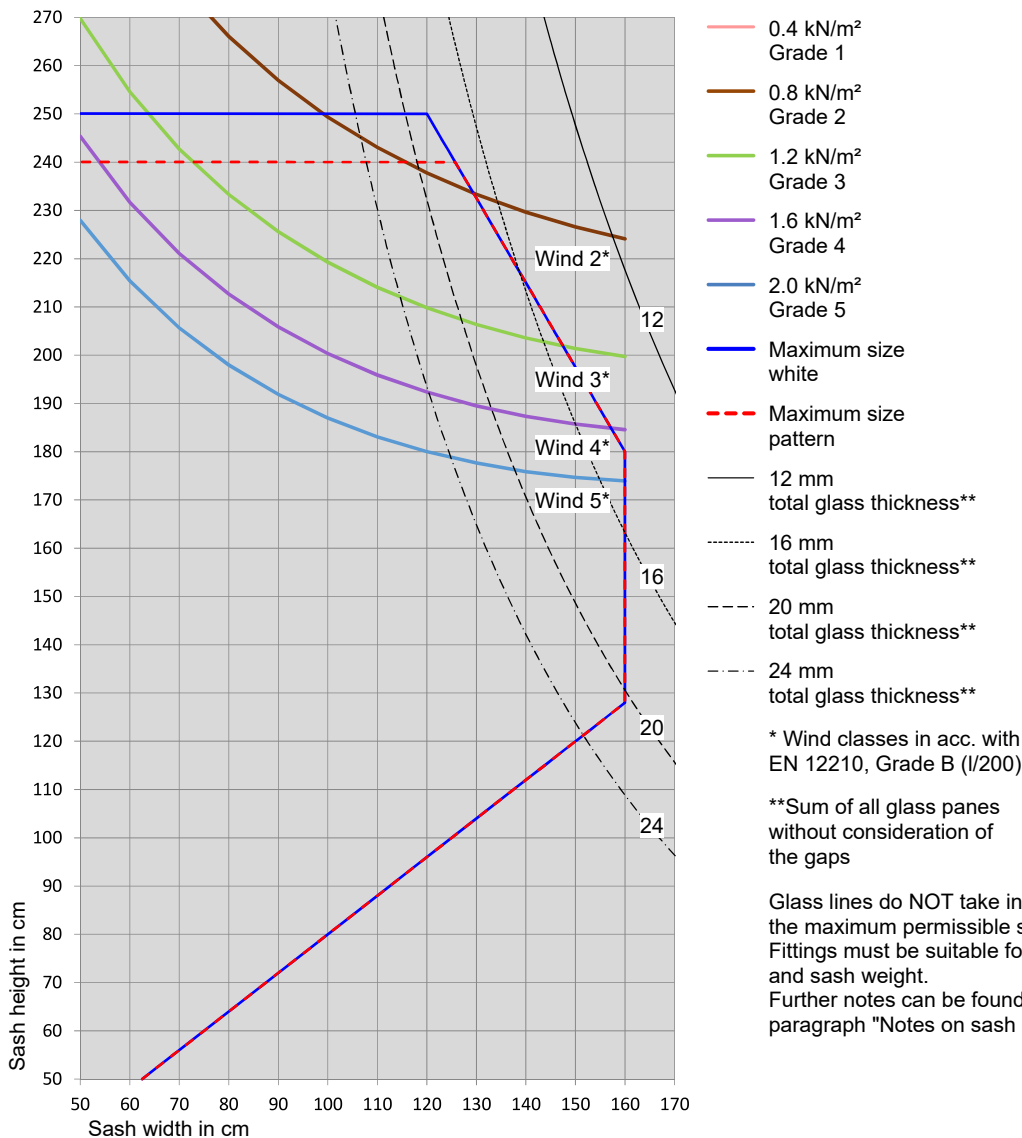
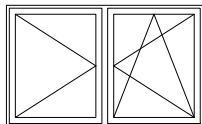

Turn-only / Tilt&Turn sash

**VS8030-73**

Size chart for strengthening VS8030, 1.5 mm - French window sash with wide faceplate

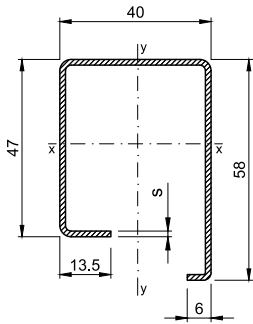

**VS8030-73**  
 Thickness 1.5 mm  
 $I_x = 8.36 \text{ cm}^4$   
 $I_y = 6.76 \text{ cm}^4$

Application for sashes

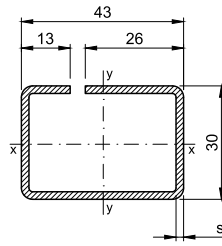
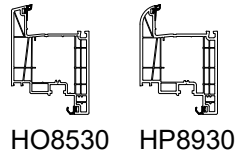

**VS9800-74**  
 Thickness 2.0 mm  
 $I_x = 3.65 \text{ cm}^4$   
 $I_y = 6.65 \text{ cm}^4$

Application for faceplate

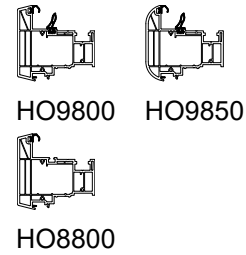

Window type 1.2 Turn-only / bottom-hung window/door

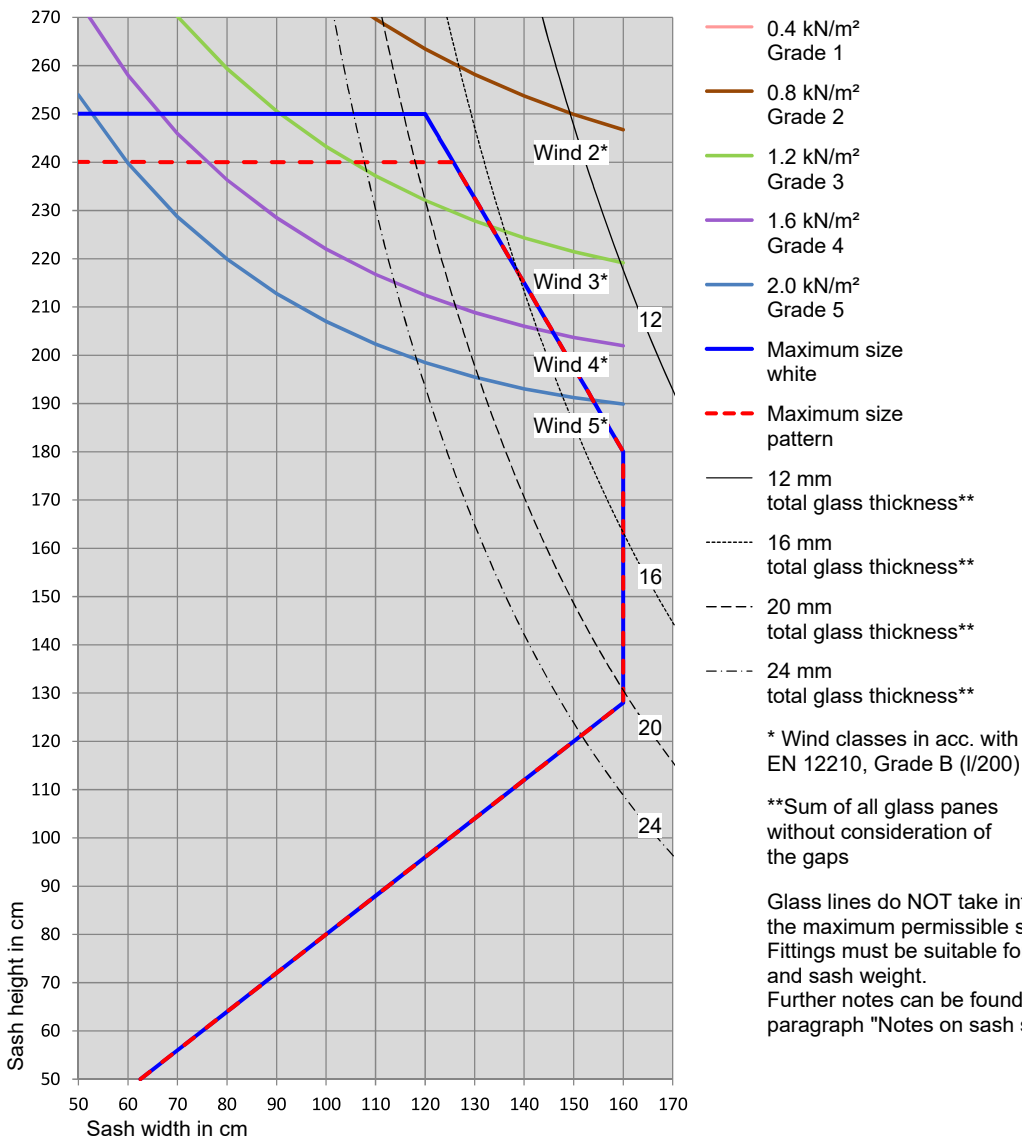
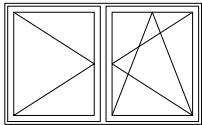

Turn-only / Tilt&Turn sash

**VS8030-74**

Size chart for strengthening VS8030, 2.0 mm - single sash

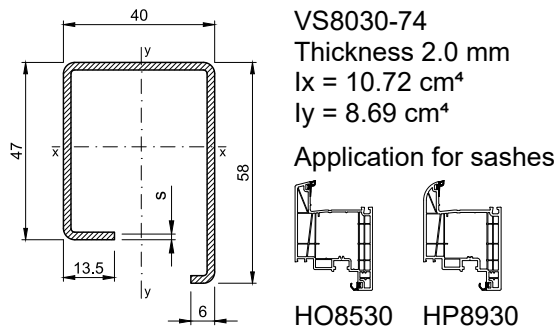

Window type 1.1 Turn-only / bottom-hung window/door

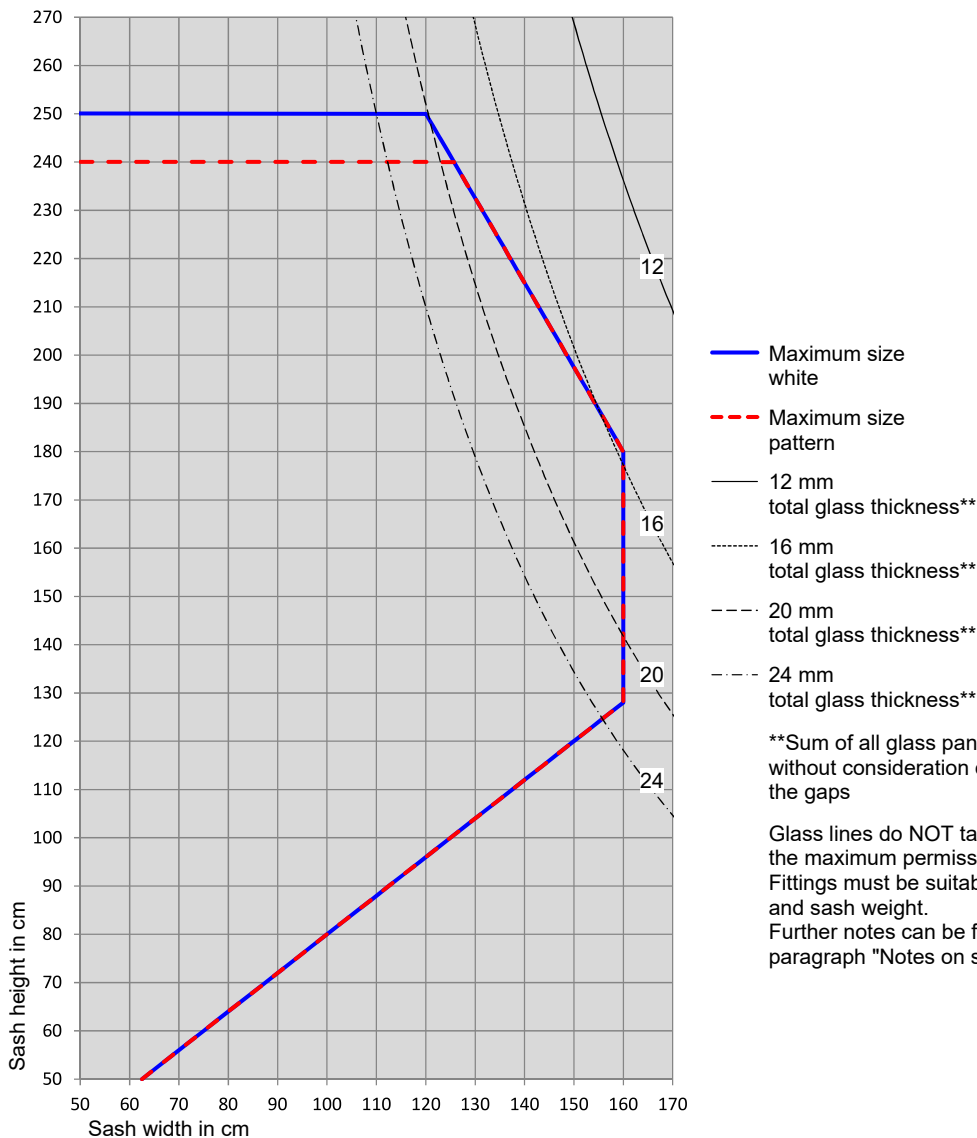
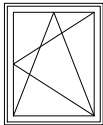

- Maximum size white
- - - Maximum size pattern
- 12 mm total glass thickness\*\*
- ..... 16 mm total glass thickness\*\*
- - - 20 mm total glass thickness\*\*
- · - · 24 mm total glass thickness\*\*

\*\*Sum of all glass panes without consideration of the gaps

Glass lines do NOT take into account the maximum permissible sash weight. Fittings must be suitable for sash size and sash weight. Further notes can be found in paragraph "Notes on sash sizes".

Turn-only / Tilt&Turn sash

**VS8030-74**

Size chart for strengthening VS8030, 2.0 mm - French window sash with wide faceplate

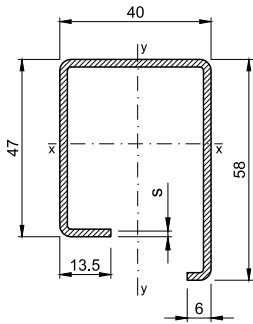

**VS8030-74**  
 Thickness 2.0 mm  
 $I_x = 10.72 \text{ cm}^4$   
 $I_y = 8.69 \text{ cm}^4$

Application for sashes

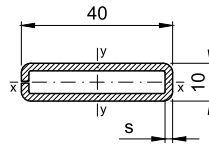
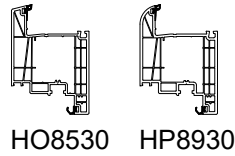

**VS9810-74**  
 Thickness 2.0 mm  
 $I_x = 0.26 \text{ cm}^4$   
 $I_y = 2.77 \text{ cm}^4$

Application for faceplate

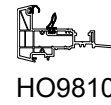

Window type 1.2 Turn-only / bottom-hung window/door

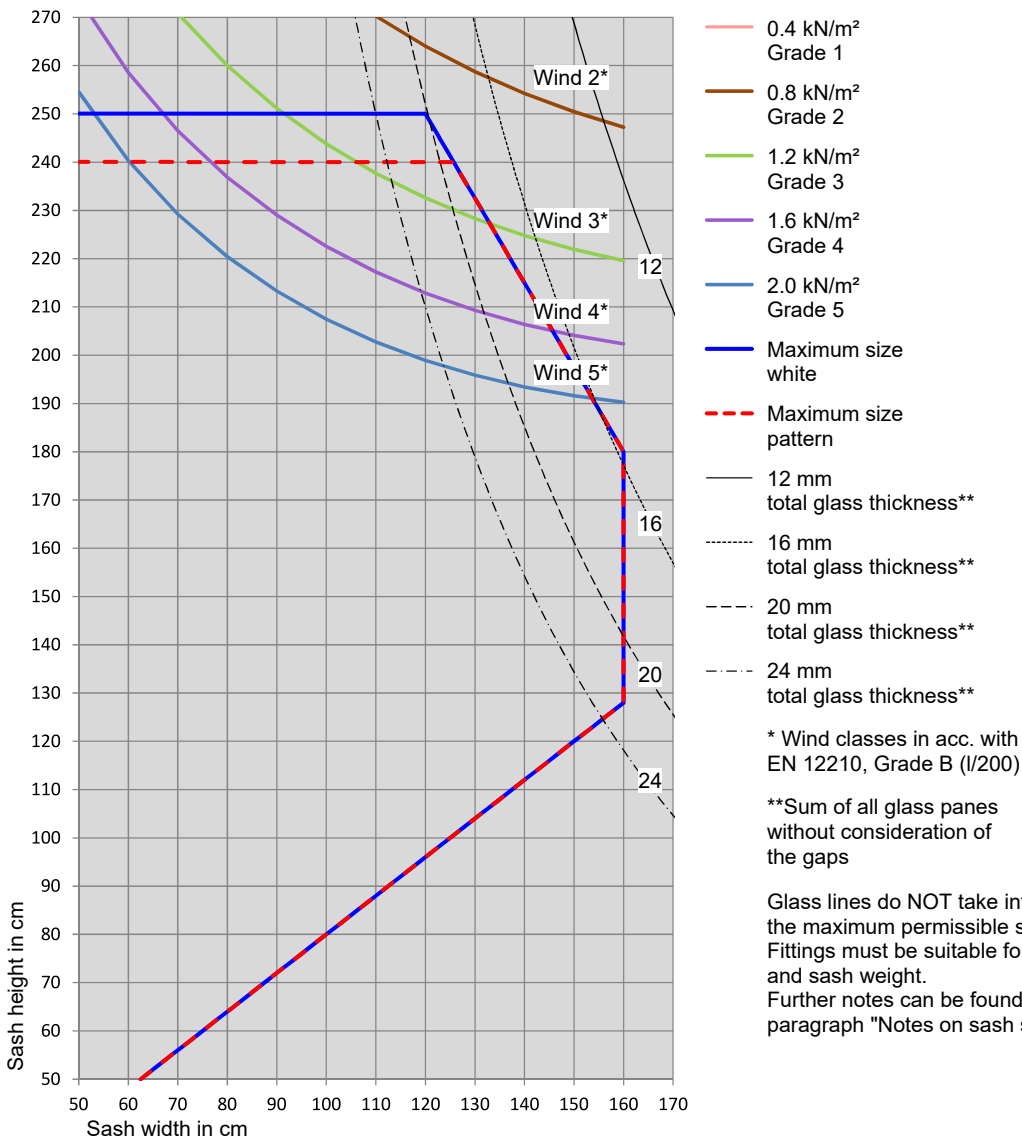
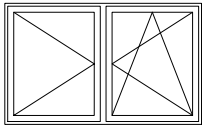

Turn-only / Tilt&Turn sash

**VS8030-74**

Size chart for strengthening VS8030, 2.0 mm - French window sash with wide faceplate

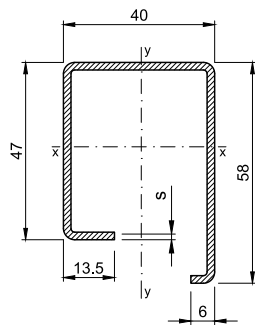

**VS8030-74**  
 Thickness 2.0 mm  
 $I_x = 10.72 \text{ cm}^4$   
 $I_y = 8.69 \text{ cm}^4$

Application for sashes

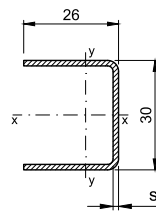
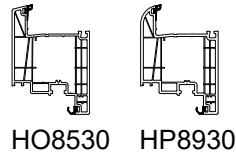

**VS8020-73**  
 Thickness 1.5 mm  
 $I_x = 1.77 \text{ cm}^4$   
 $I_y = 0.82 \text{ cm}^4$

Application for faceplate

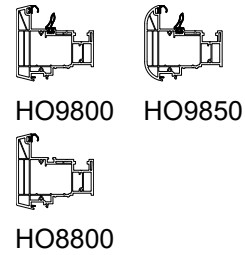

Window type 1.2 Turn-only / bottom-hung window/door

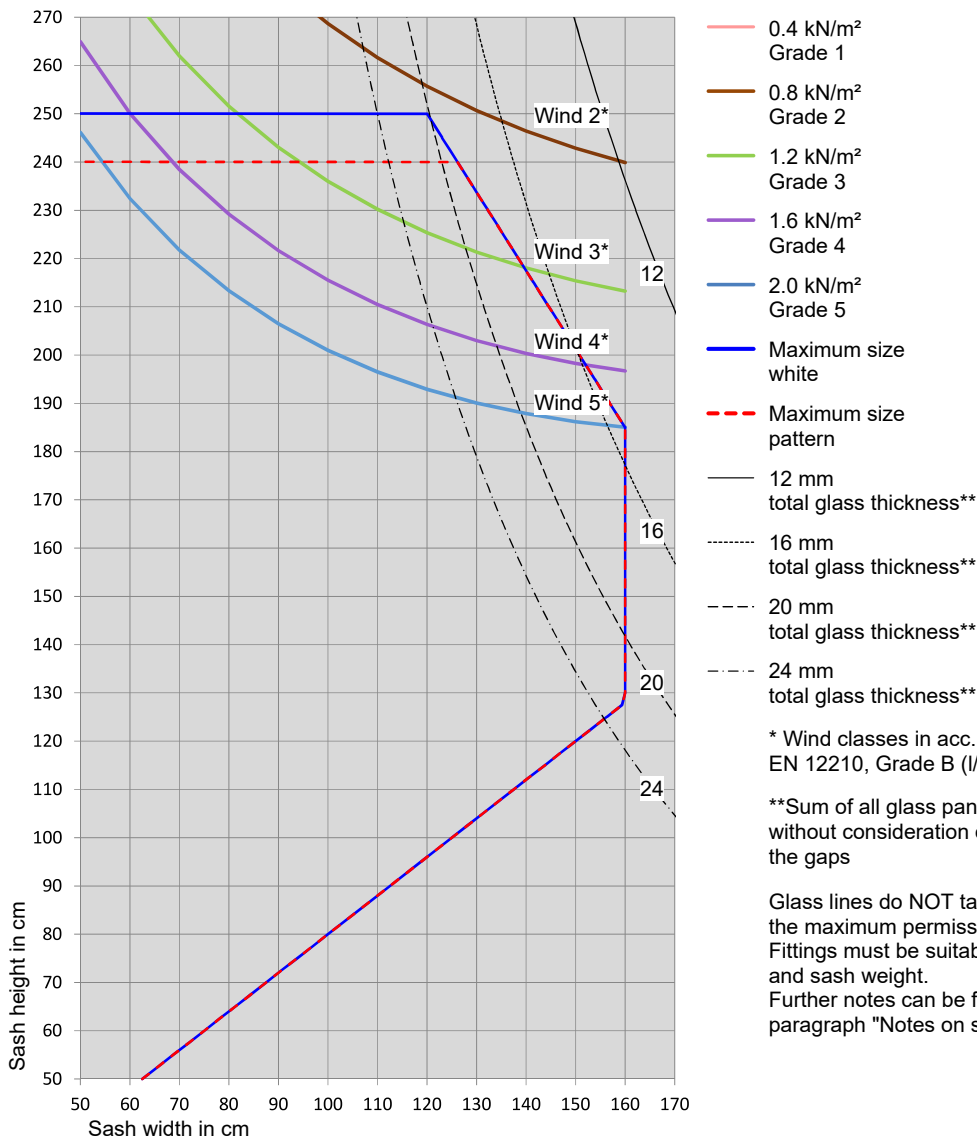
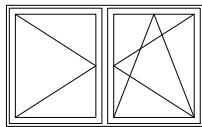

Turn-only / Tilt&Turn sash

**VS8030-74**

Size chart for strengthening VS8030, 2.0 mm - French window sash with wide faceplate

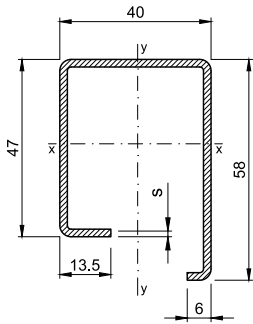

**VS8030-74**  
 Thickness 2.0 mm  
 $I_x = 10.72 \text{ cm}^4$   
 $I_y = 8.69 \text{ cm}^4$

Application for sashes

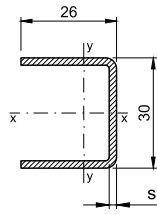
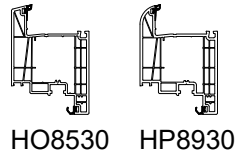

**VS8020-74**  
 Thickness 2.0 mm  
 $I_x = 2.26 \text{ cm}^4$   
 $I_y = 1.06 \text{ cm}^4$

Application for faceplate

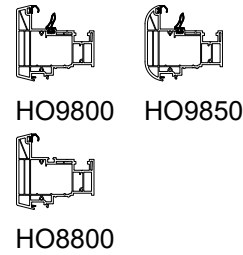

Window type 1.2 Turn-only / bottom-hung window/door

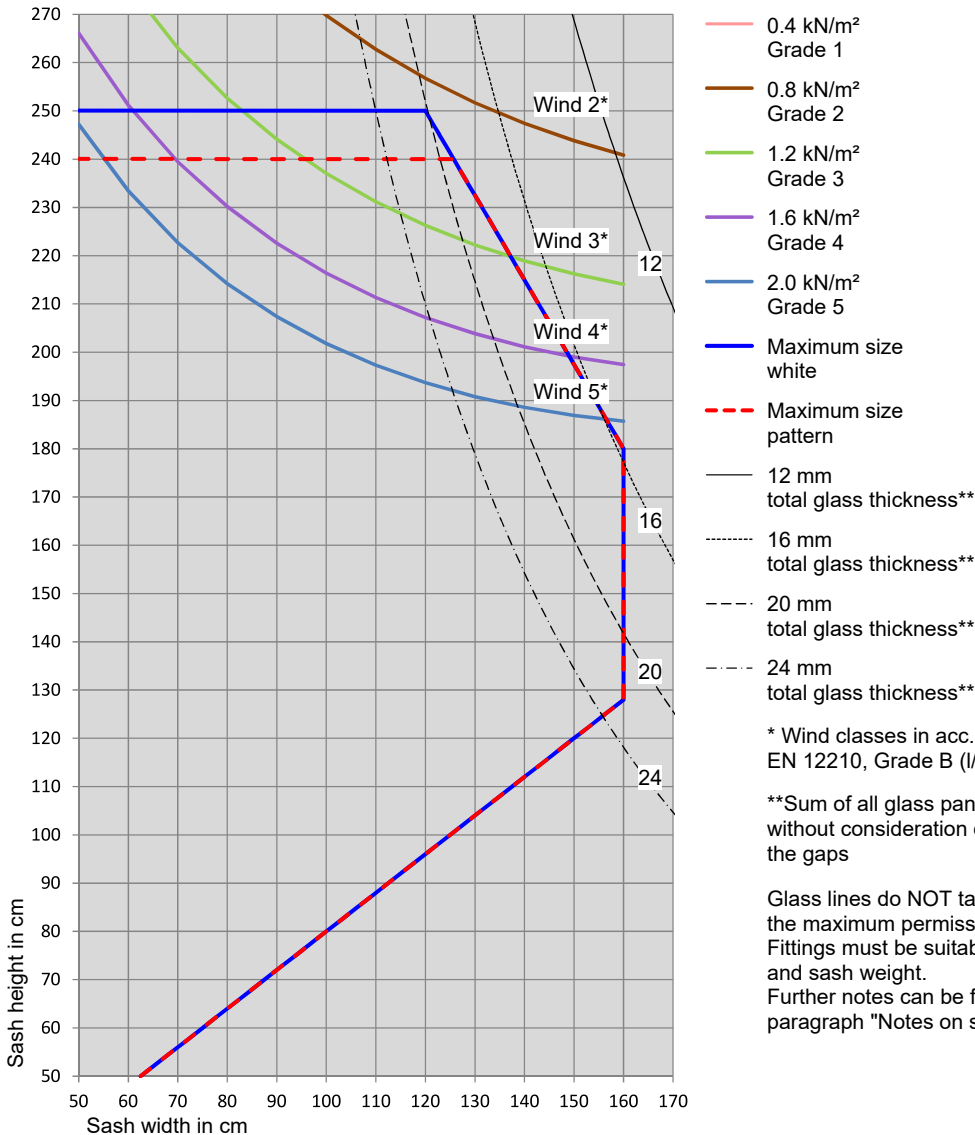
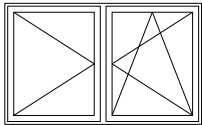

Turn-only / Tilt&Turn sash

**VS8030-74**

Size chart for strengthening VS8030, 2.0 mm - French window sash with wide faceplate

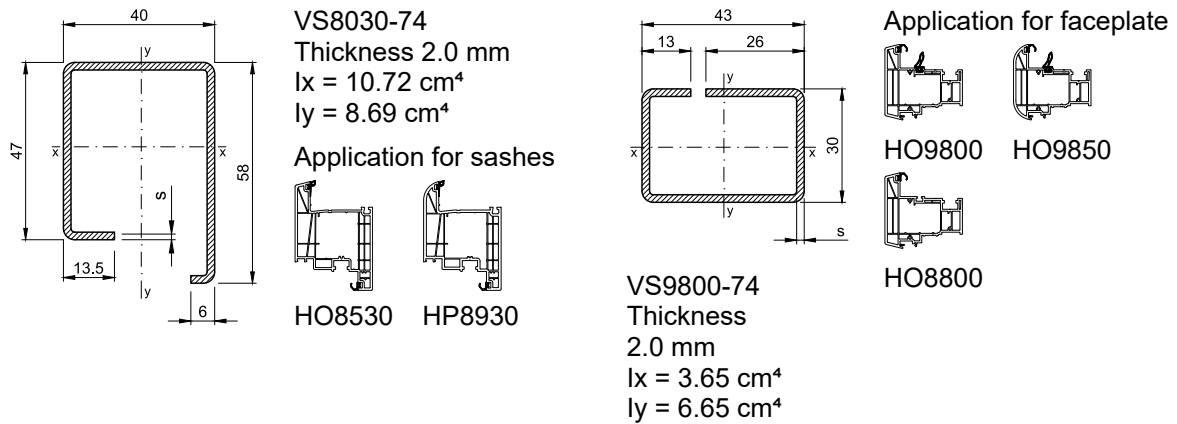

Window type 1.2 Turn-only / bottom-hung window/door

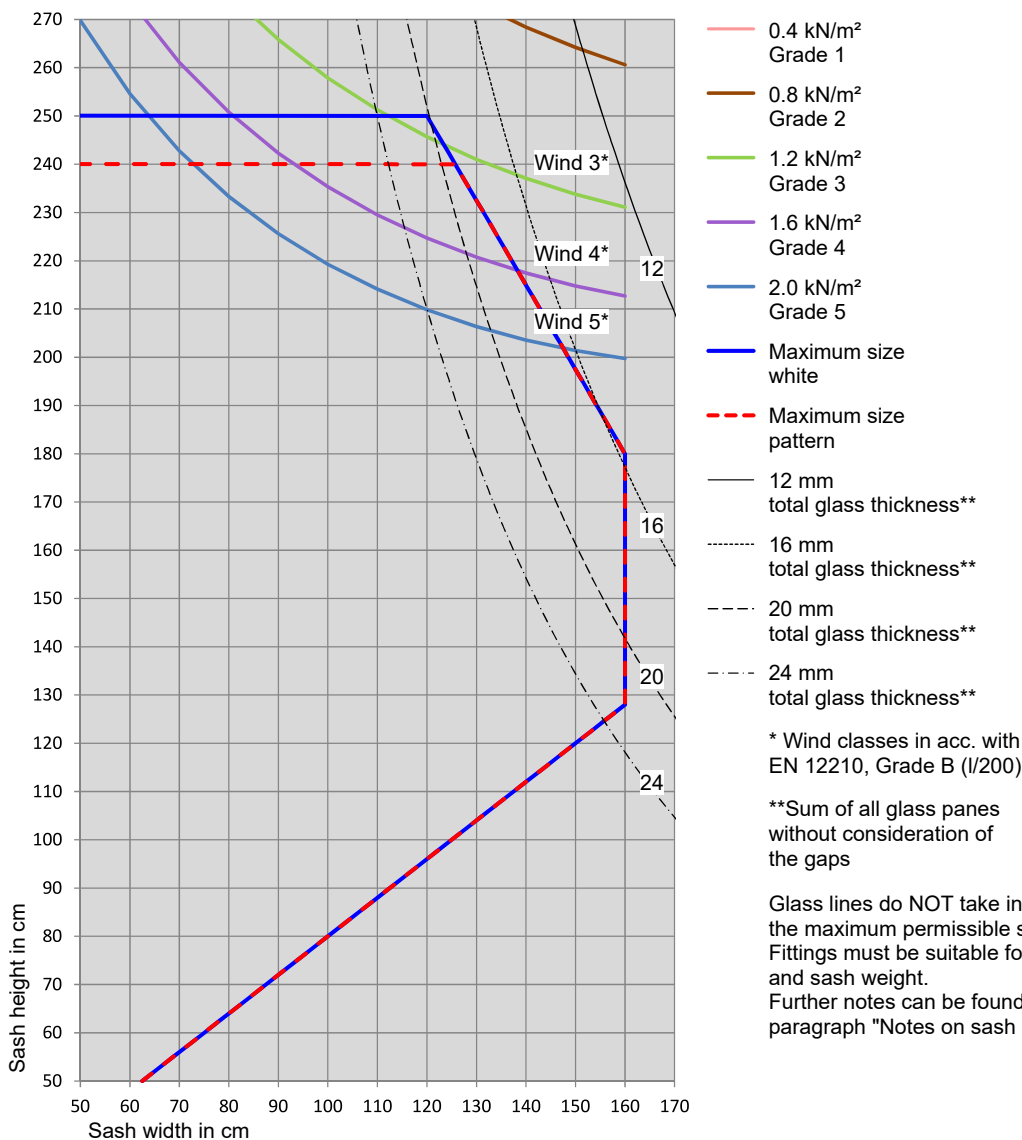
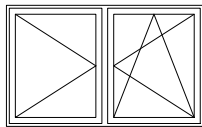

Turn-only / Tilt&Turn sash

**VS8450-74**

Size chart for strengthening VS8450, 2.0 mm - single sash

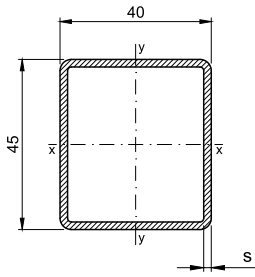

Application for sashes

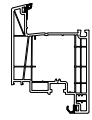

HO8530

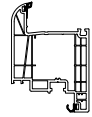

HP8930

VS8450-74

thickness

2.0 mm

$l_x = 9.36 \text{ cm}^4$

$l_y = 7.80 \text{ cm}^4$

Window type 1.1 Turn-only / bottom-hung window/door

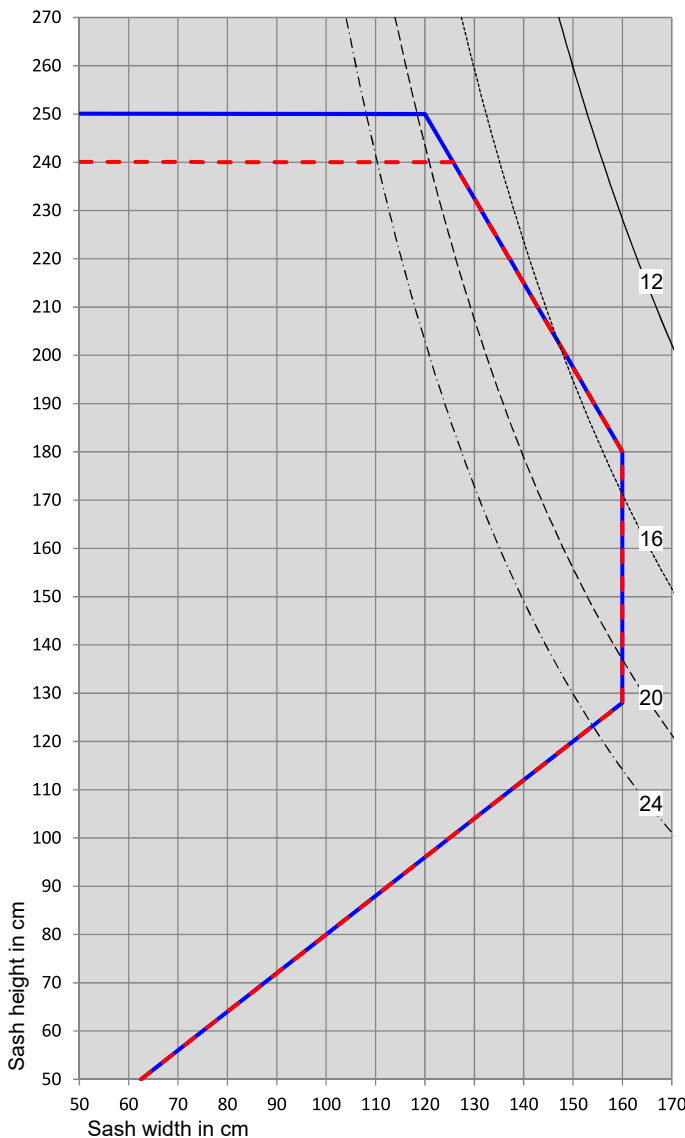
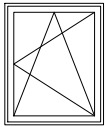

- Maximum size white
- - - Maximum size pattern
- 12 mm total glass thickness\*\*
- ..... 16 mm total glass thickness\*\*
- - - 20 mm total glass thickness\*\*
- · - · 24 mm total glass thickness\*\*

\*\*Sum of all glass panes without consideration of the gaps

Glass lines do NOT take into account the maximum permissible sash weight. Fittings must be suitable for sash size and sash weight. Further notes can be found in paragraph "Notes on sash sizes".

Turn-only / Tilt&Turn sash

**VS8450-74**

Size chart for strengthening VS8450, 2.0 mm - French window sash with wide faceplate

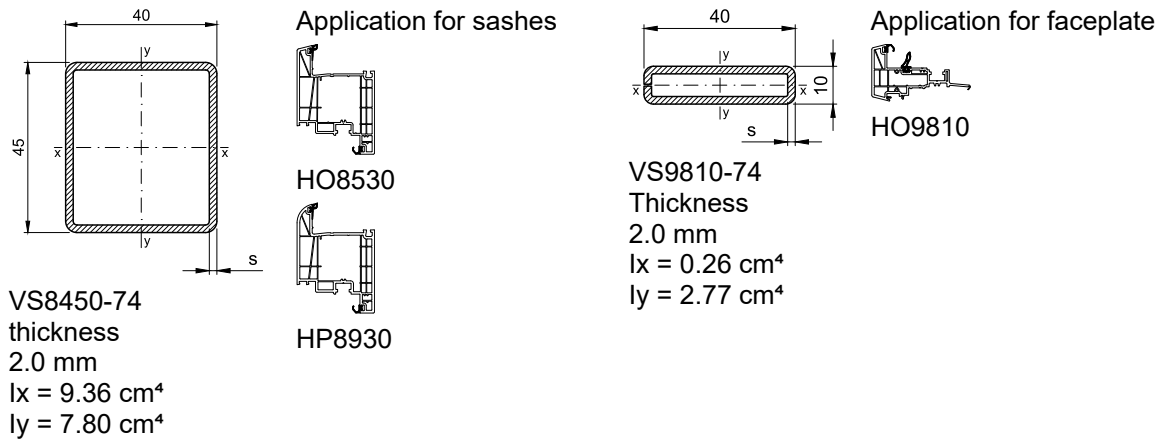

Window type 1.2 Turn-only / bottom-hung window/door

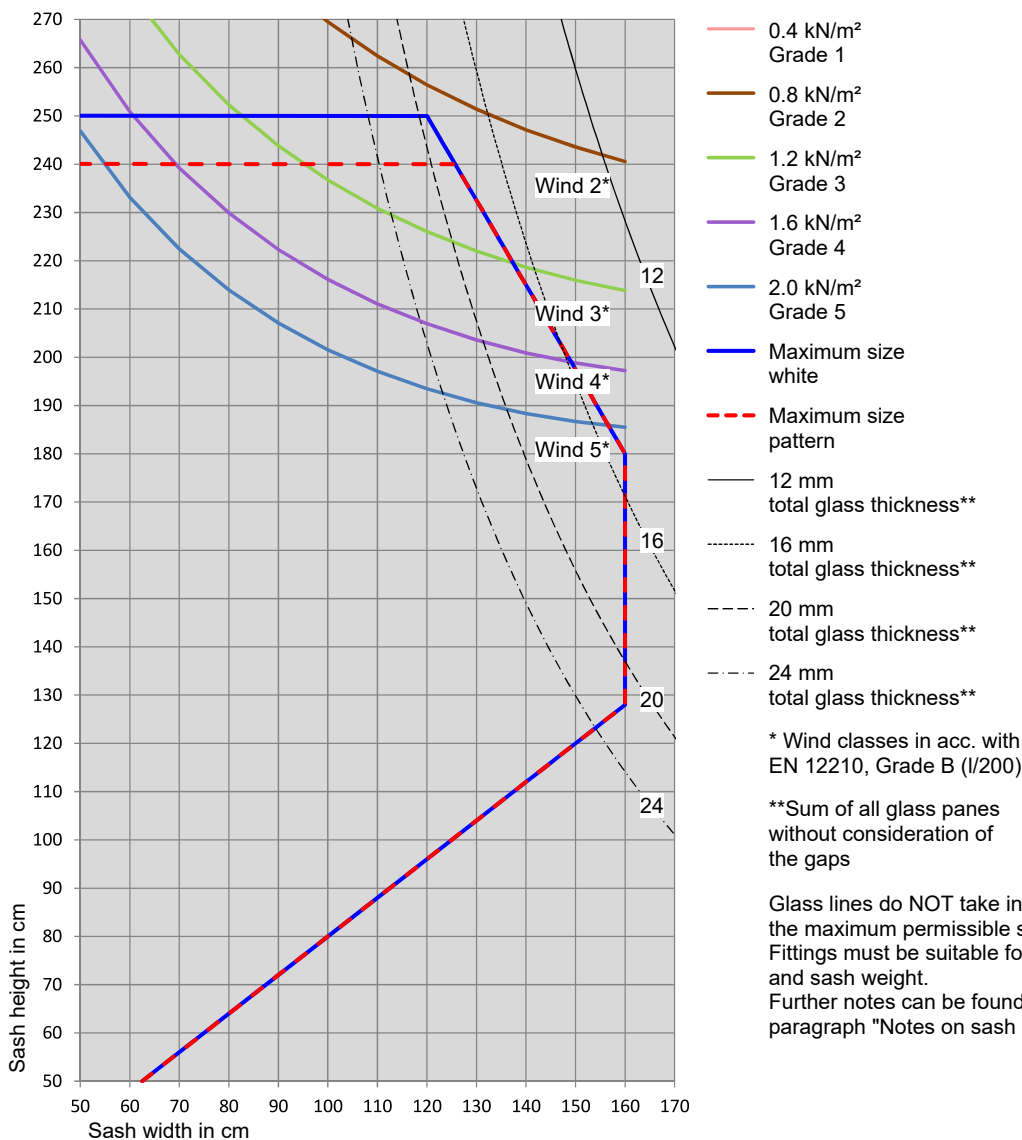
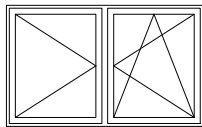

Turn-only / Tilt&Turn sash

**VS8450-74**

Size chart for strengthening VS8450, 2.0 mm - French window sash with wide faceplate

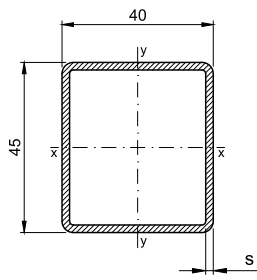

Application for sashes



HO8530

HP8930

VS8450-74  
thickness  
2.0 mm  
 $I_x = 9.36 \text{ cm}^4$   
 $I_y = 7.80 \text{ cm}^4$

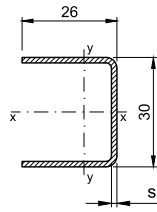

Application for faceplate

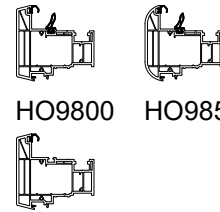

HO9800

HO9850

HO8800

VS8020-73  
Thickness 1,5 mm  
 $I_x = 1.77 \text{ cm}^4$   
 $I_y = 0.82 \text{ cm}^4$

Window type 1.2 Turn-only / bottom-hung window/door

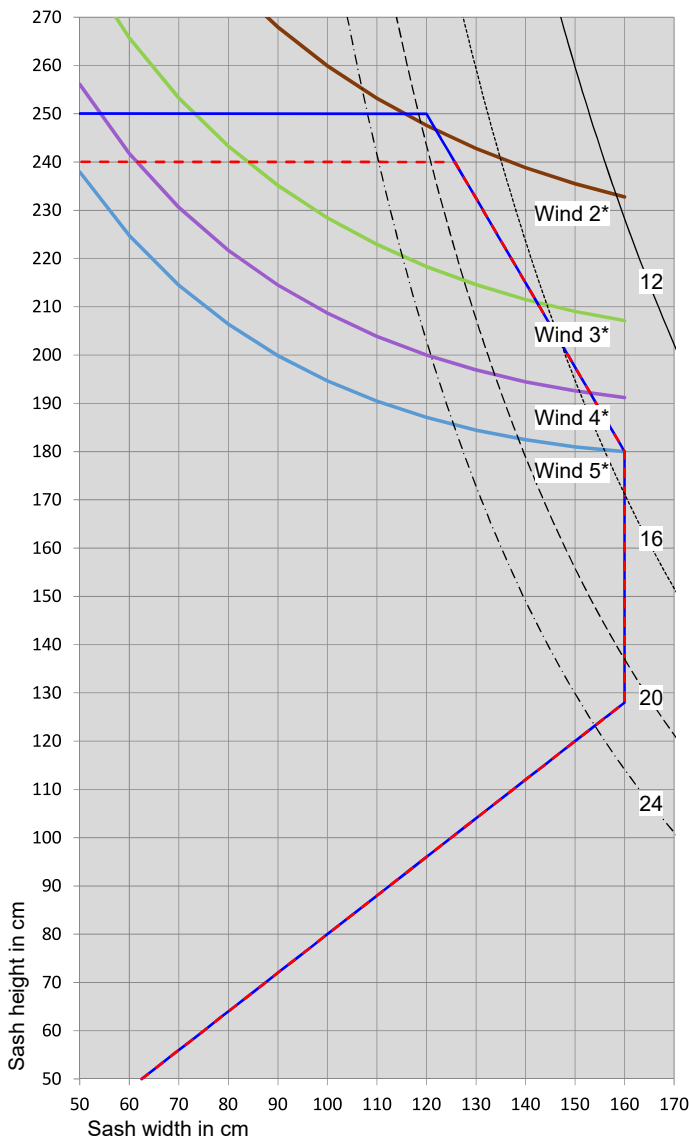
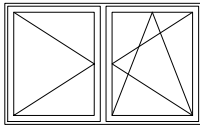

- 0.4 kN/m<sup>2</sup> Grade 1
- 0.8 kN/m<sup>2</sup> Grade 2
- 1.2 kN/m<sup>2</sup> Grade 3
- 1.6 kN/m<sup>2</sup> Grade 4
- 2.0 kN/m<sup>2</sup> Grade 5
- Maximum size white
- - - Maximum size pattern
- 12 mm total glass thickness\*\*
- · - · - 16 mm total glass thickness\*\*
- - - - 20 mm total glass thickness\*\*
- · - · - 24 mm total glass thickness\*\*

\* Wind classes in acc. with EN 12210, Grade B (I/200)

\*\*Sum of all glass panes without consideration of the gaps

Glass lines do NOT take into account the maximum permissible sash weight. Fittings must be suitable for sash size and sash weight. Further notes can be found in paragraph "Notes on sash sizes".

Turn-only / Tilt&Turn sash

**VS8450-74**

Size chart for strengthening VS8450, 2.0 mm - French window sash with wide faceplate

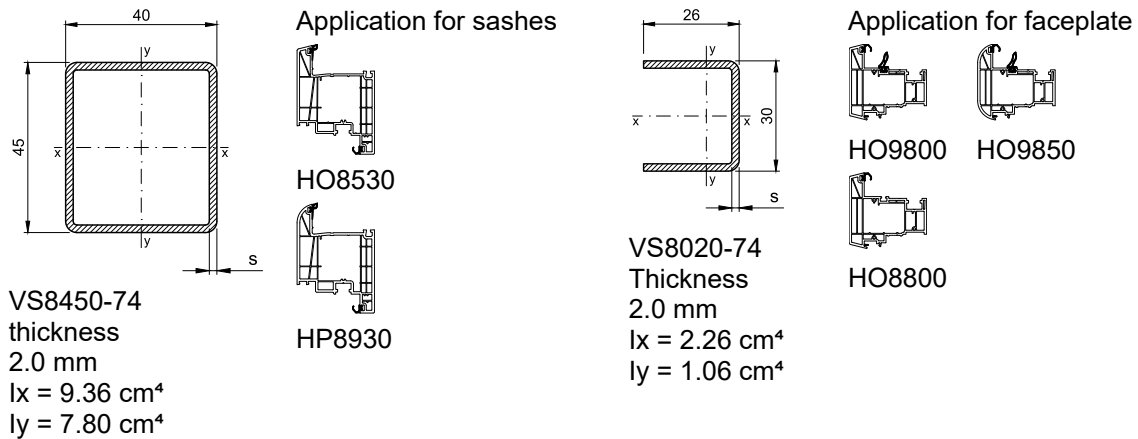

Window type 1.2 Turn-only / bottom-hung window/door

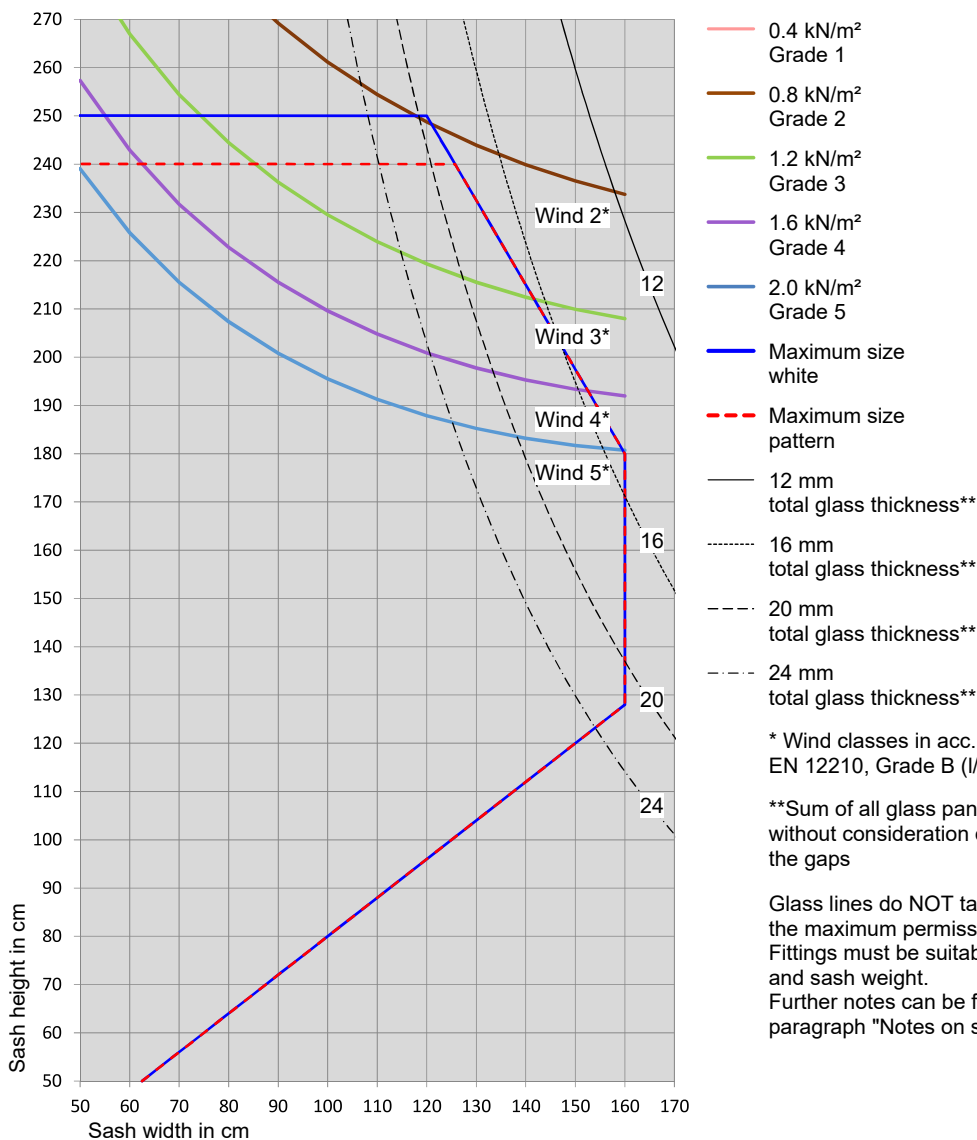
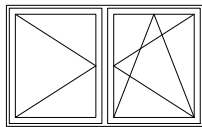

\* Wind classes in acc. with EN 12210, Grade B (I/200)

\*\*Sum of all glass panes without consideration of the gaps

Glass lines do NOT take into account the maximum permissible sash weight. Fittings must be suitable for sash size and sash weight. Further notes can be found in paragraph "Notes on sash sizes".

Turn-only / Tilt&Turn sash

**VS8450-74**

Size chart for strengthening VS8450, 2.0 mm - French window sash with wide faceplate

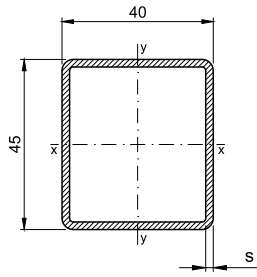

Application for sashes



HO8530

HP8930

VS8450-74  
thickness  
2.0 mm  
 $I_x = 9.36 \text{ cm}^4$   
 $I_y = 7.80 \text{ cm}^4$

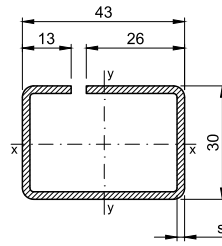

Application for faceplate

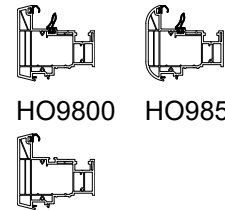

HO9800

HO9850

HO8800

VS9800-74  
Thickness  
2.0 mm  
 $I_x = 3.65 \text{ cm}^4$   
 $I_y = 6.65 \text{ cm}^4$

Window type 1.2 Turn-only / bottom-hung window/door

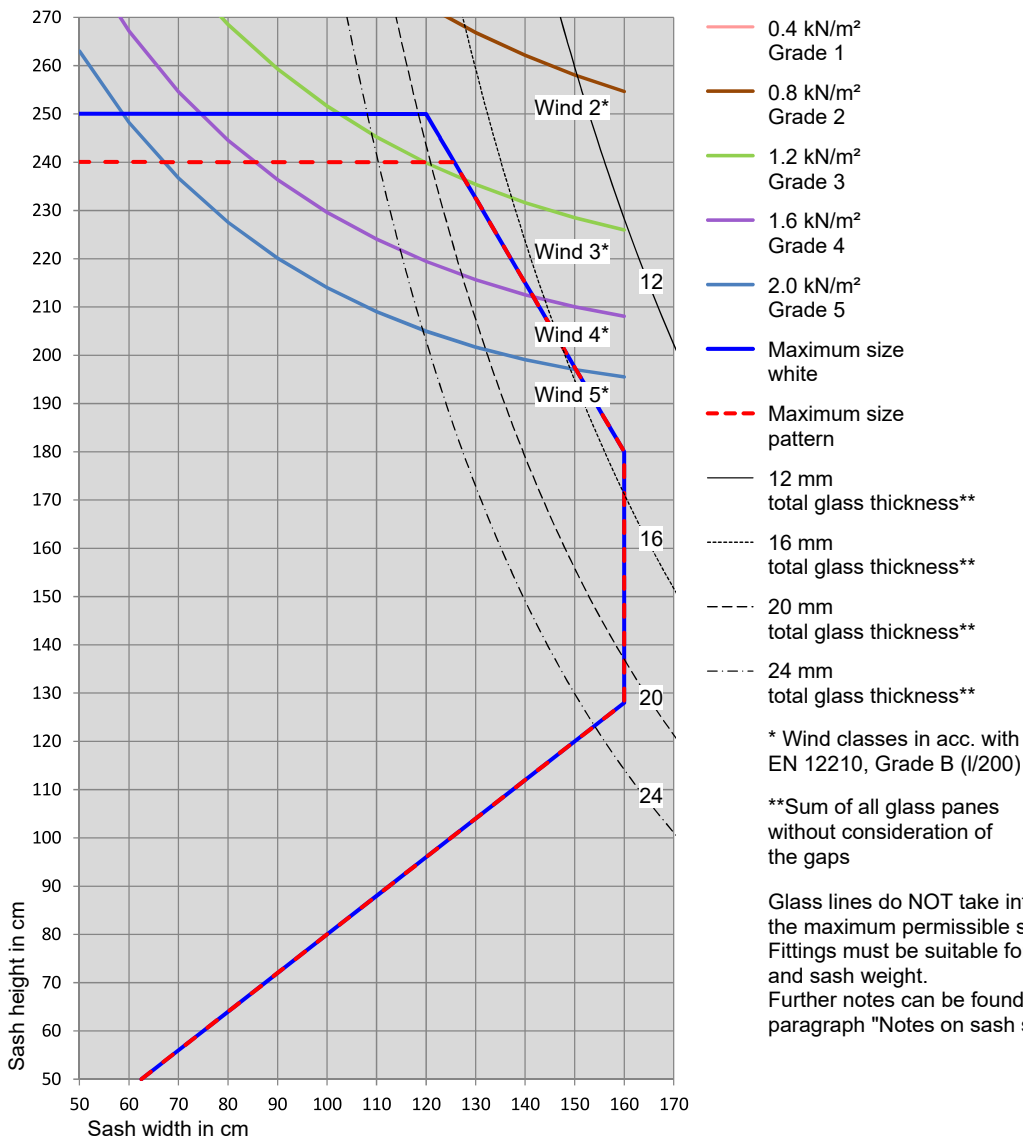
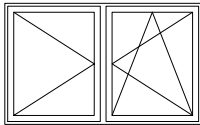

Turn-Only/Tilt&Turn sash

**VS9029**

Size chart for strengthening VS9029, 1.5 mm - single sash

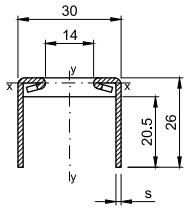

VS9029  
Thickness  
1.5 mm  
 $I_x = 0.74 \text{ cm}^4$   
 $I_y = 1.90 \text{ cm}^4$

Application for sashes



HO8520



HO8521



HP8920

Window type 1.1 Turn-only / bottom-hung window/door

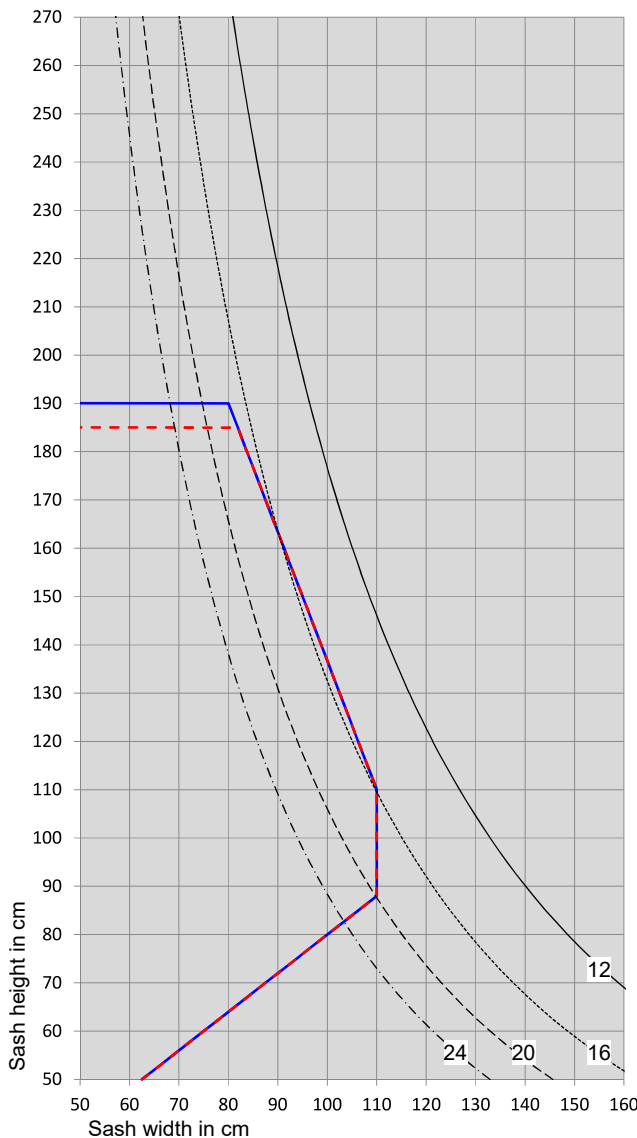
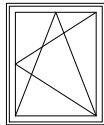

- Maximum size white
- - - Maximum size pattern
- 12 mm total glass thickness\*\*
- ..... 16 mm total glass thickness\*\*
- - - 20 mm total glass thickness\*\*
- · - · 24 mm total glass thickness\*\*

\*\*Sum of all glass panes without consideration of the gaps

Glass lines do NOT take into account the maximum permissible sash weight. Fittings must be suitable for sash size and sash weight. Further notes can be found in paragraph "Notes on sash sizes".

Turn-Only/Tilt&Turn sash

VS9029

Size chart for strengthening VS9029, 1.5 mm - French window sash with wide faceplate

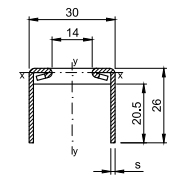

Application for sashes



HO8520



HO8521



HP8920

VS9029  
Thickness 1,5 mm  
 $I_x = 0.74 \text{ cm}^4$   
 $I_y = 1.90 \text{ cm}^4$

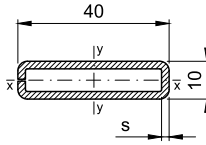

Application for faceplate



HO9810

VS9810-74  
Thickness  
2.0 mm  
 $I_x = 0.26 \text{ cm}^4$   
 $I_y = 2.77 \text{ cm}^4$

Window type 1.2 Turn-only / bottom-hung window/door

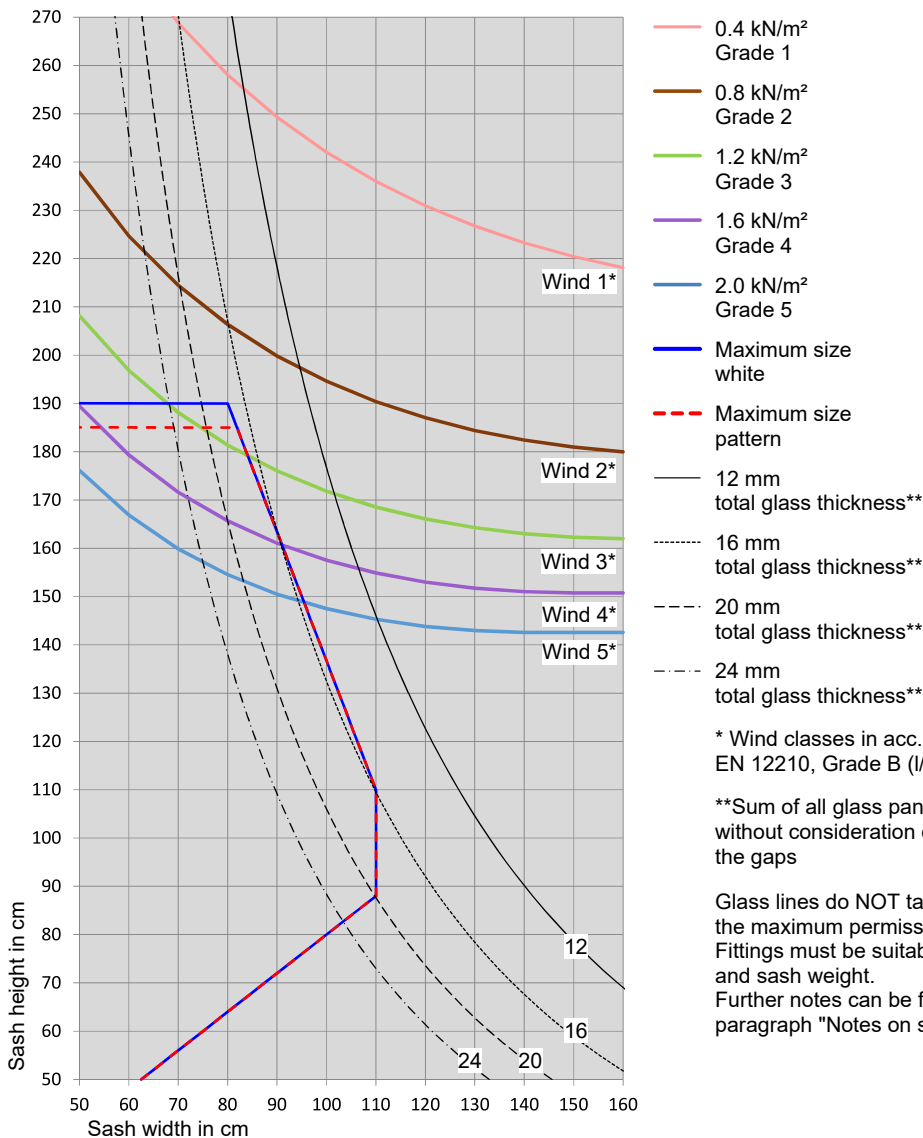
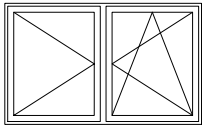

Turn-Only/Tilt&Turn sash

**VS9029**

Size chart for strengthening VS9029, 1.5 mm - French window sash with wide faceplate

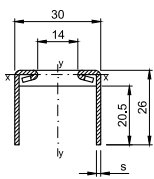

Application for sashes



VS9029  
Thickness  
1.5 mm  
 $I_x = 0.74 \text{ cm}^4$   
 $I_y = 1.90 \text{ cm}^4$

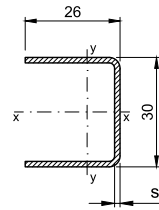

Application for faceplate

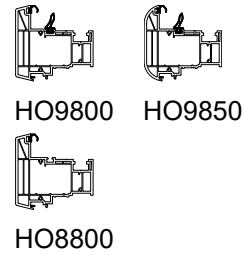

VS8020-73  
Thickness  
1.5 mm  
 $I_x = 1.77 \text{ cm}^4$   
 $I_y = 0.82 \text{ cm}^4$

Window type 1.2 Turn-only / bottom-hung window/door

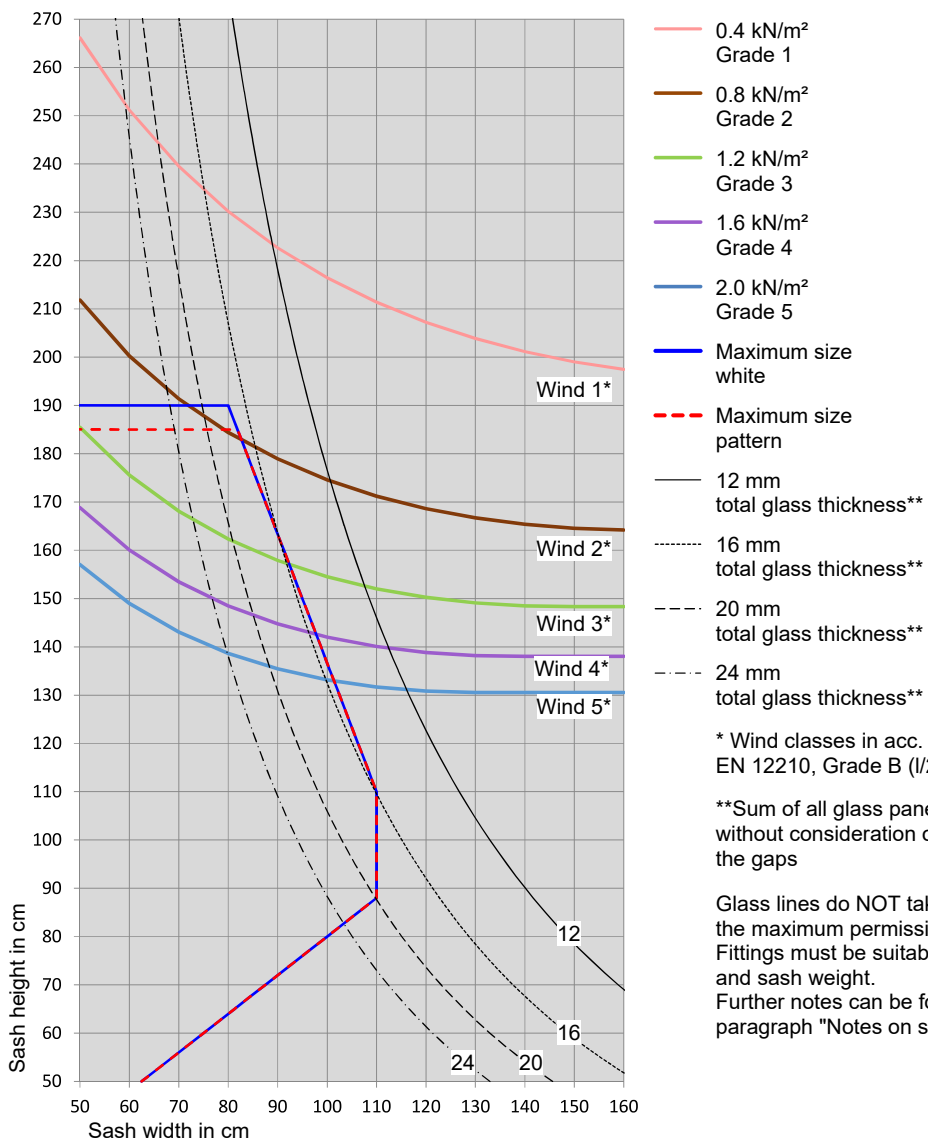
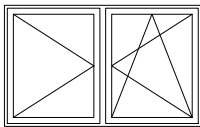

\* Wind classes in acc. with EN 12210, Grade B (I/200)

\*\*Sum of all glass panes without consideration of the gaps

Glass lines do NOT take into account the maximum permissible sash weight. Fittings must be suitable for sash size and sash weight. Further notes can be found in paragraph "Notes on sash sizes".

Turn-Only/Tilt&Turn sash

VS9029

Size chart for strengthening VS9029, 1.5 mm - French window sash with wide faceplate

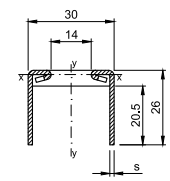

Application for sashes



HO8520



HO8521



HP8920

VS9029  
Thickness  
1.5 mm  
 $I_x = 0.74 \text{ cm}^4$   
 $I_y = 1.90 \text{ cm}^4$

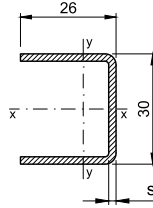

Application for faceplate



HO9800



HO9850



HO8800

VS8020-74  
Thickness  
2.0 mm  
 $I_x = 2.26 \text{ cm}^4$   
 $I_y = 1.06 \text{ cm}^4$



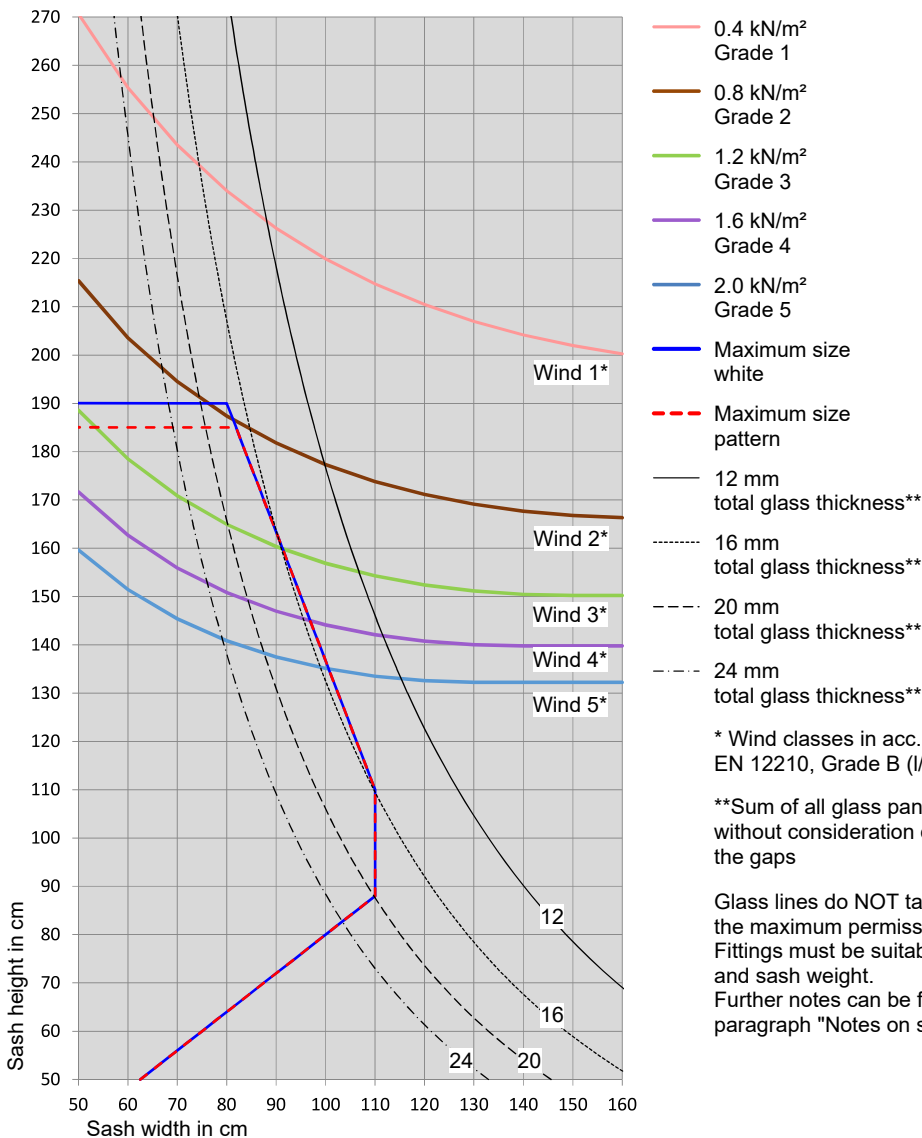
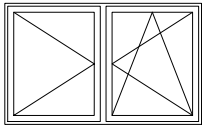





Window type 1.2 Turn-only / bottom-hung window/door

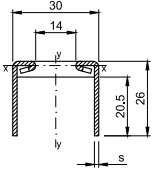

Turn-Only/Tilt&Turn sash

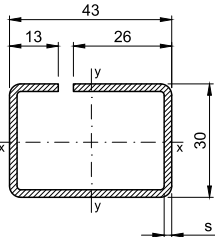
**VS9029**

Size chart for strengthening VS9029, 1.5 mm - French window sash with wide faceplate

 <p><b>VS9029</b> Thickness 1.5 mm <math>I_x = 0.74 \text{ cm}^4</math> <math>I_y = 1.90 \text{ cm}^4</math></p>	<p><b>Application for sashes</b></p>  <p>HO8520</p>  <p>HO8521</p>  <p>HP8920</p>	 <p><b>VS9800-74</b> Thickness 2.0 mm <math>I_x = 3.65 \text{ cm}^4</math> <math>I_y = 6.65 \text{ cm}^4</math></p>	<p><b>Application for faceplate</b></p>  <p>HO9800</p>  <p>HO9850</p>  <p>HO8800</p>
---	--	--	---

Window type 1.2 Turn-only / bottom-hung window/door

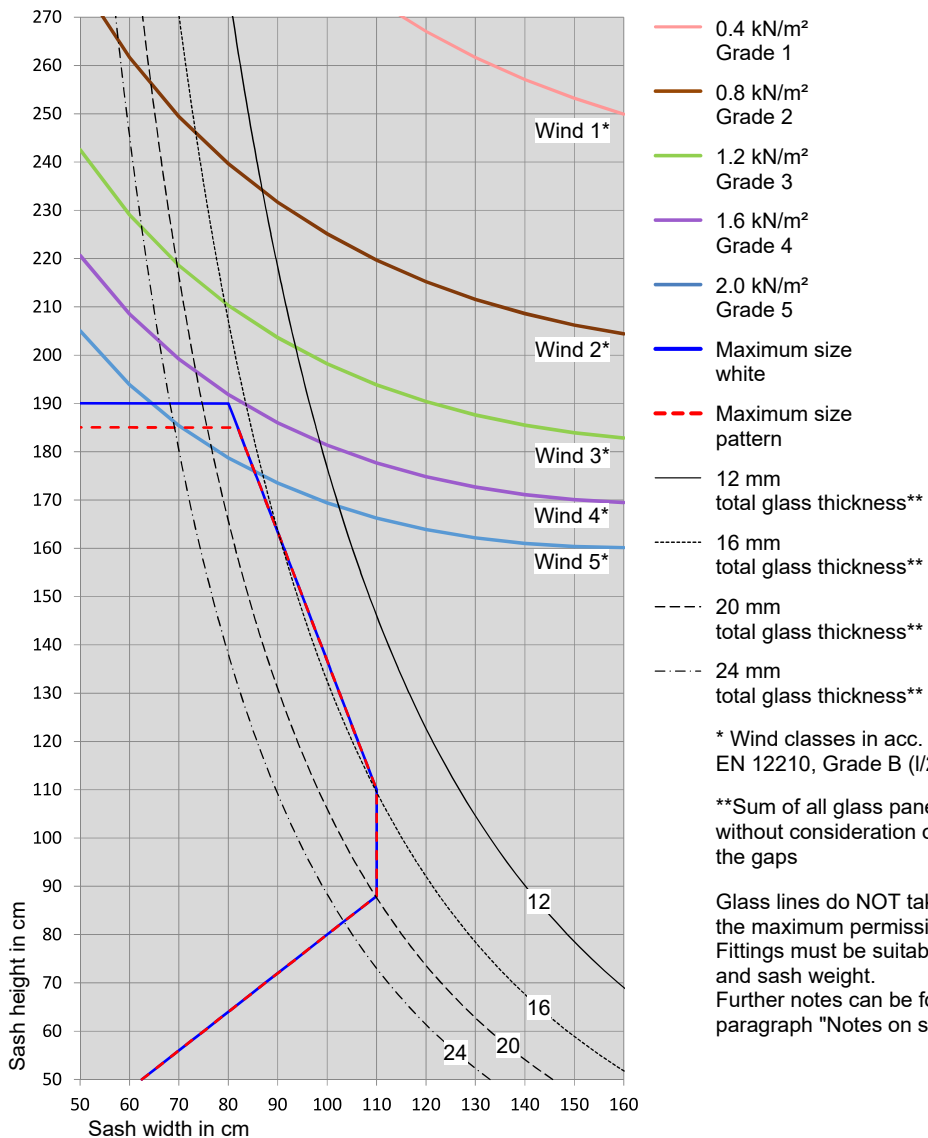
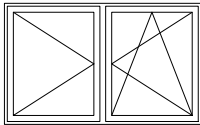

Back door

**VS8030-73**

Size diagram for strengthening VS8030, 1.5 mm - back door

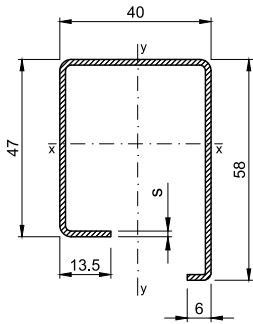

VS8030-73  
 Thickness 1.5 mm  
 $I_x = 8.36 \text{ cm}^4$   
 $I_y = 6.76 \text{ cm}^4$

Application for sashes

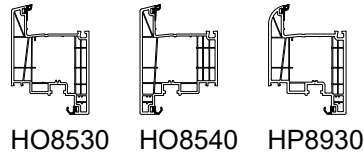

Window type 3.1 Main door

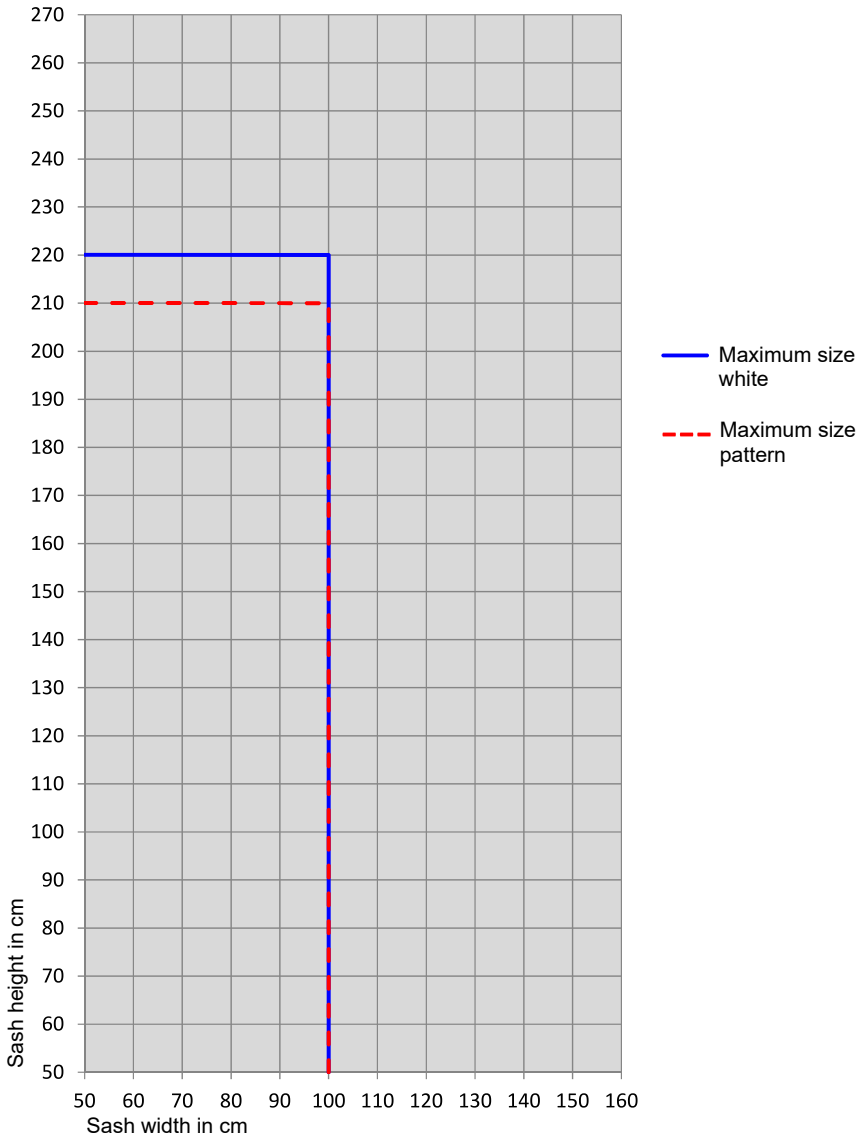
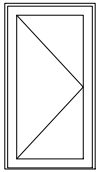

Back door

**VS8030-74**

Size diagram for strengthening VS8030, 2.0 mm - back door

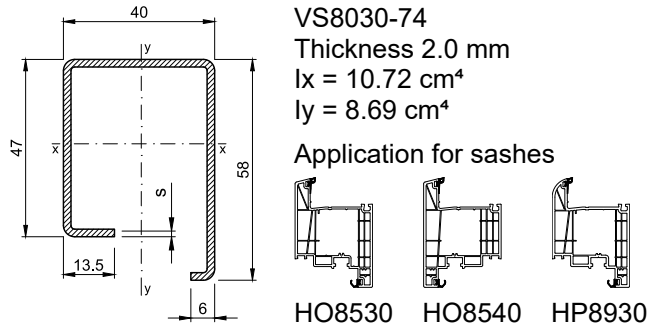

Window type 3.1 Main door

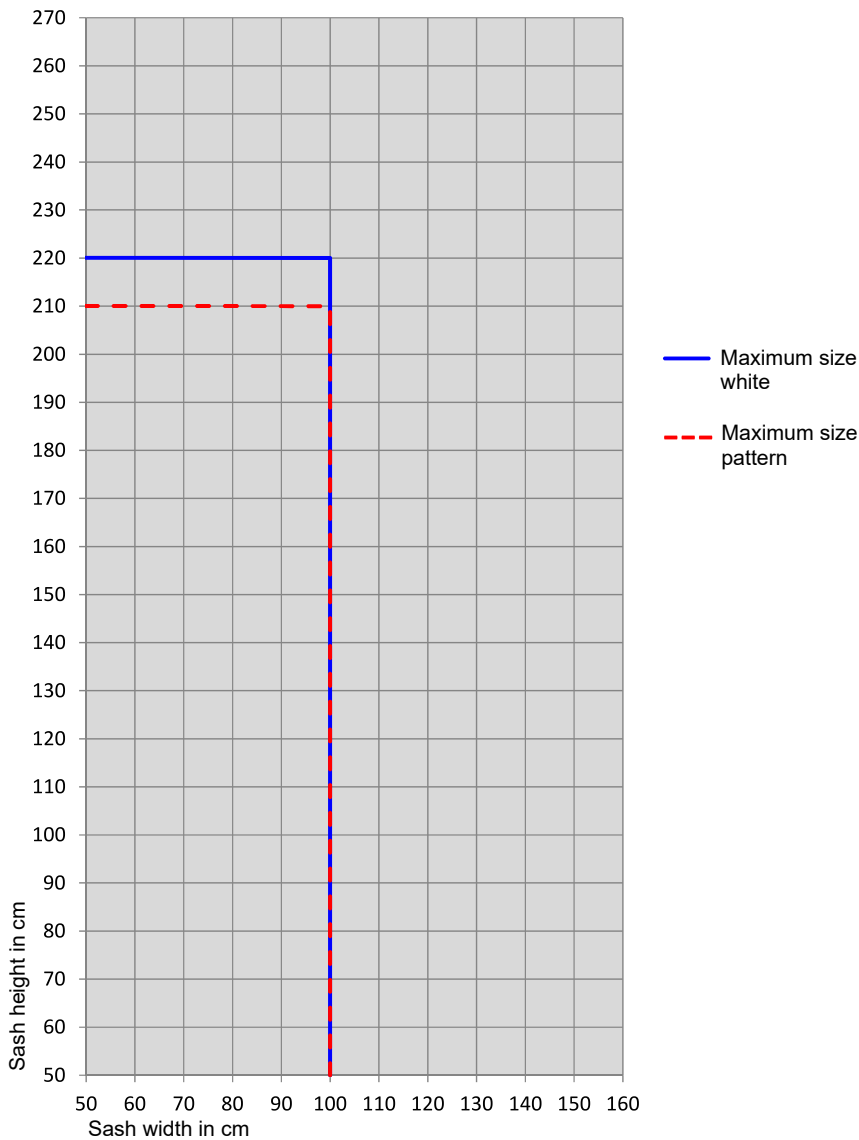
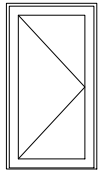

Back door

**VS8450-74**

Size diagram for strengthening VS8450, 2.0 mm - back door

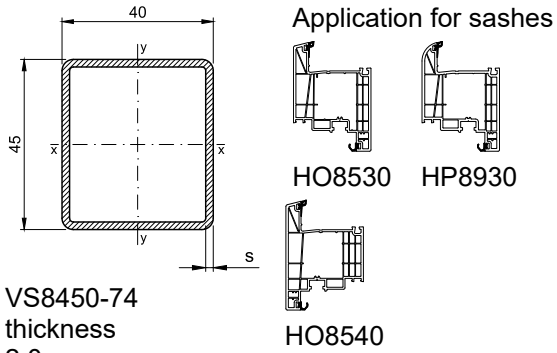

VS8450-74  
thickness  
2.0 mm  
 $I_x = 9.36 \text{ cm}^4$   
 $I_y = 7.80 \text{ cm}^4$

Window type 3.1 Main door

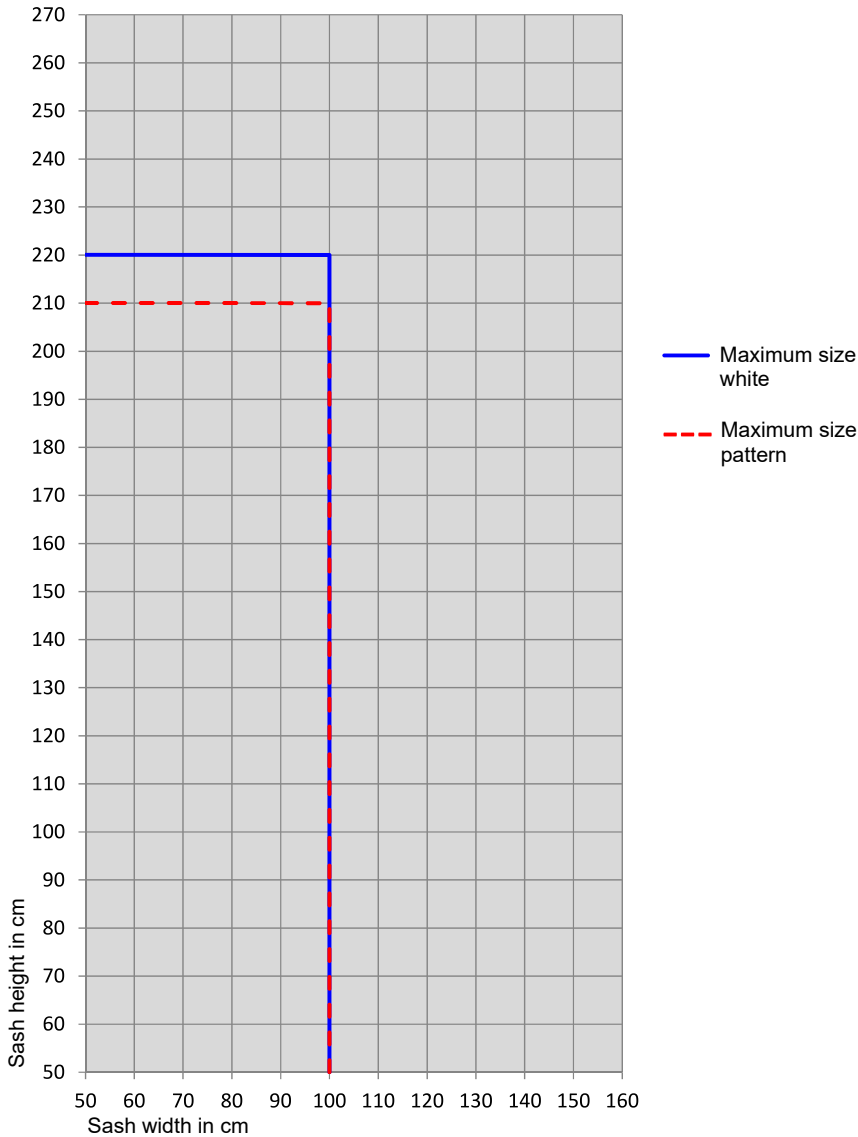
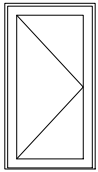

Main door

**AR4630-74**

Size diagram for strengthening AR4630, 2.0 mm - main door

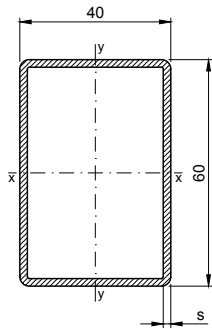

AR4630-74  
 thickness 2.0 mm  
 $I_x = 18.86 \text{ cm}^4$   
 $I_y = 10.03 \text{ cm}^4$

Application for sashes

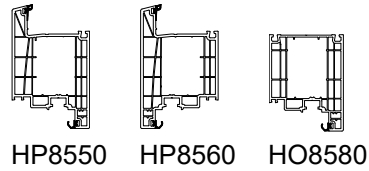

Window type 3.1 Main door

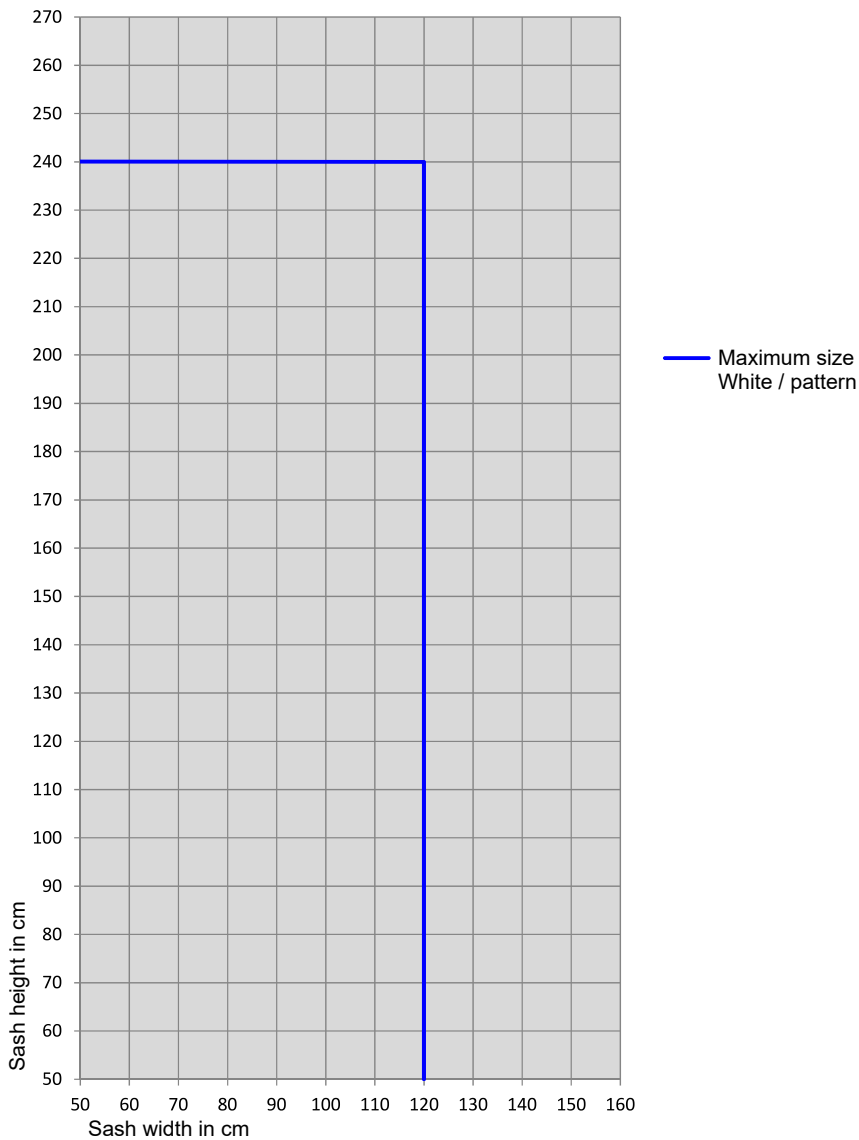
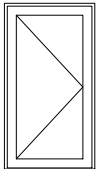

PSK door, window

**VS8050-74**

Size diagram for strengthening VS8050, 2.0 mm - PSK door/window

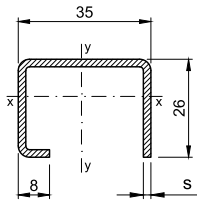

Application for sashes



HO8520



HO8521



HP8920

VS8050-74  
Thickness  
2.0 mm  
 $I_x = 1.40 \text{ cm}^4$   
 $I_y = 3.41 \text{ cm}^4$

Window type 2.1 PSK doors/windows

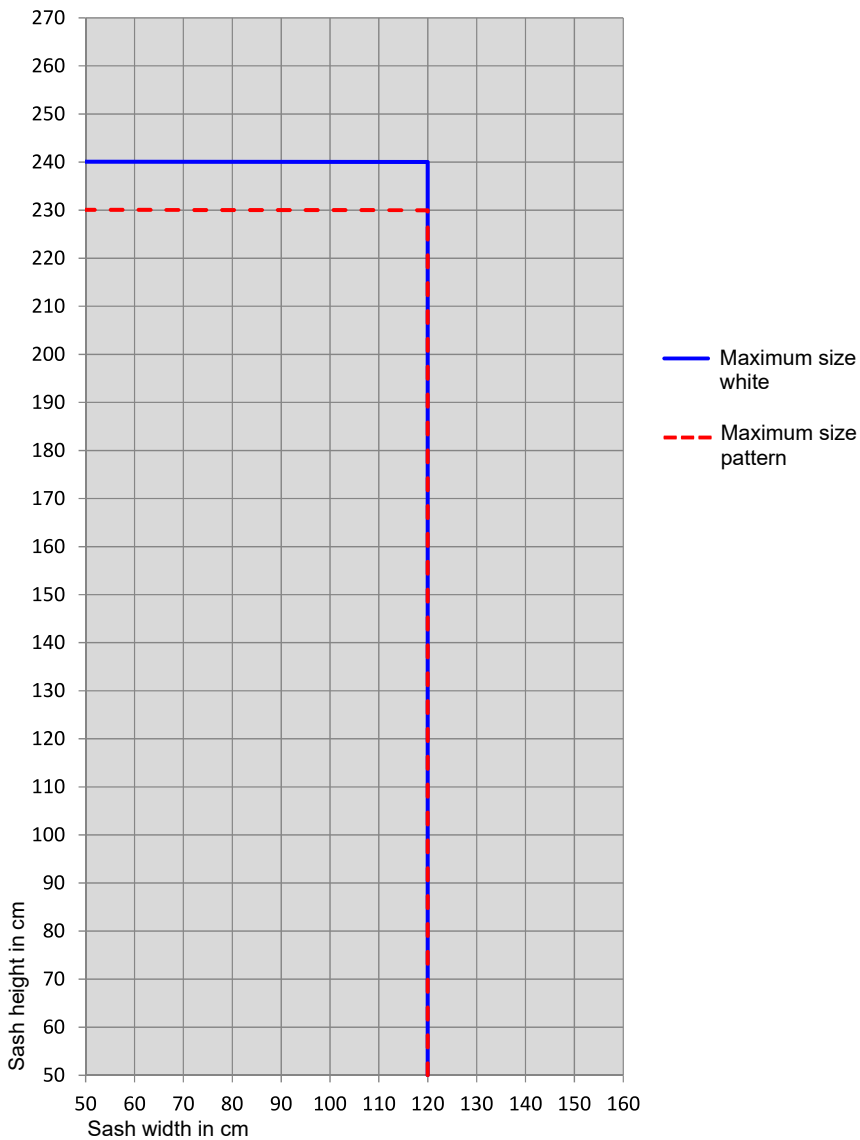
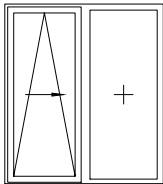

PSK door, window

**VS8055-75**

Size diagram for strengthening VS8055 2.5 mm - PSK door/window

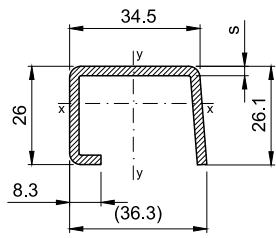

Application for sashes



HO8520



HO8521



HP8920

VS8055-75  
Thickness  
2.5 mm  
 $I_x = 1.65 \text{ cm}^4$   
 $I_y = 4.09 \text{ cm}^4$

Window type 2.1 PSK doors/windows

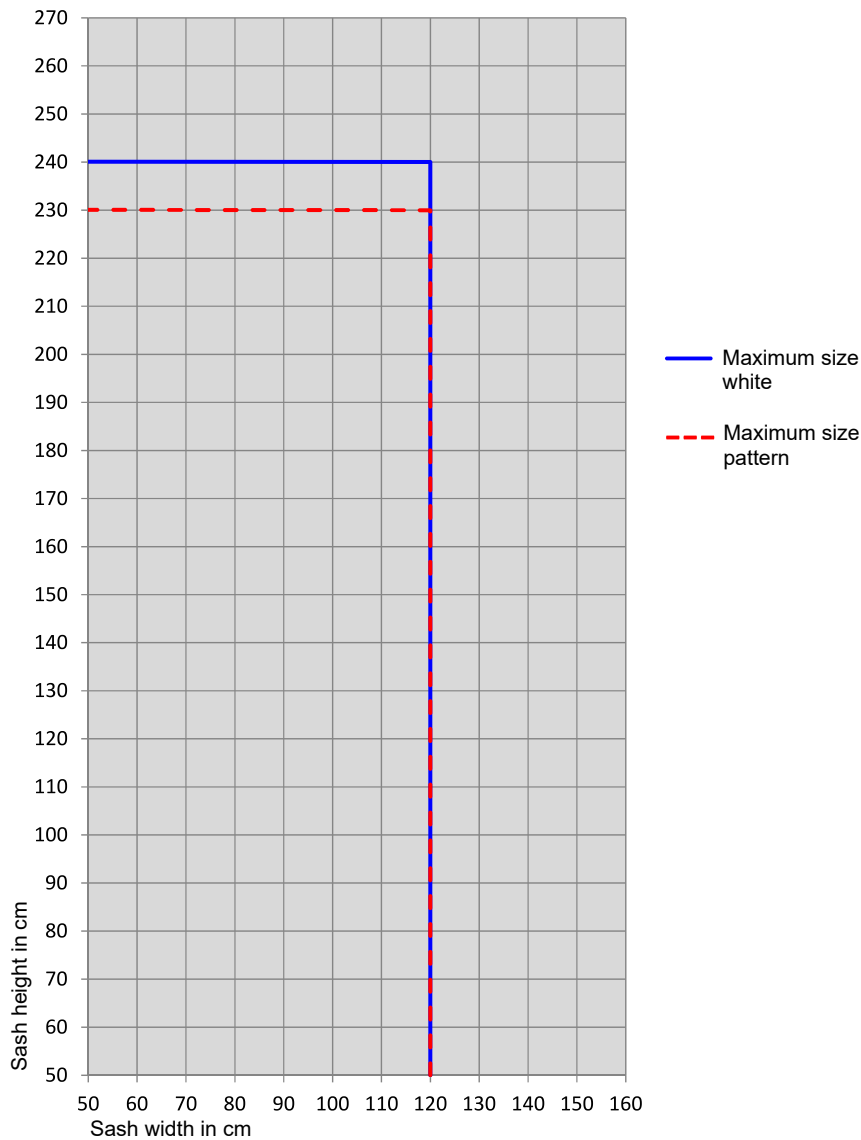
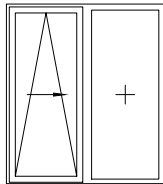

PSK door, window

**VS8030-73**

Size diagram for strengthening VS8030 1.5 mm - PSK door/window

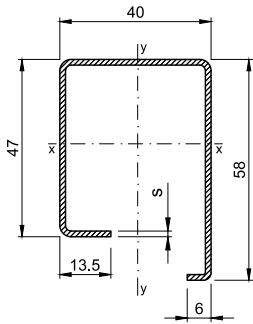

VS8030-73  
 Thickness 1.5 mm  
 $I_x = 8.36 \text{ cm}^4$   
 $I_y = 6.76 \text{ cm}^4$

Application for sashes

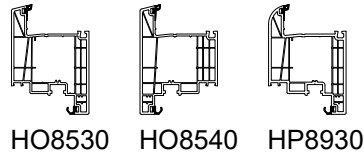

Window type 2.1 PSK doors/windows

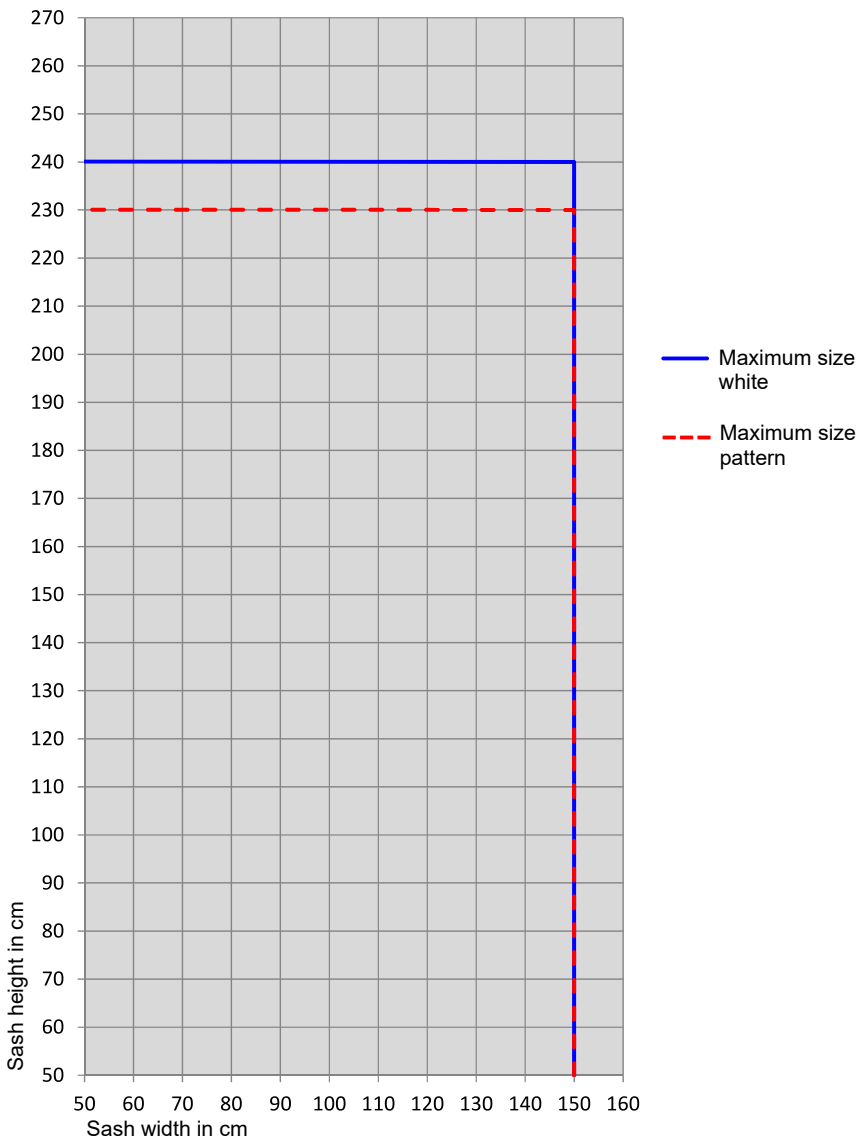
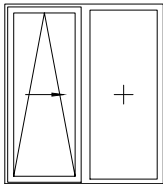

PSK door, window

**VS8030-74**

Size diagram for strengthening VS8030 2.0 mm - PSK door/window

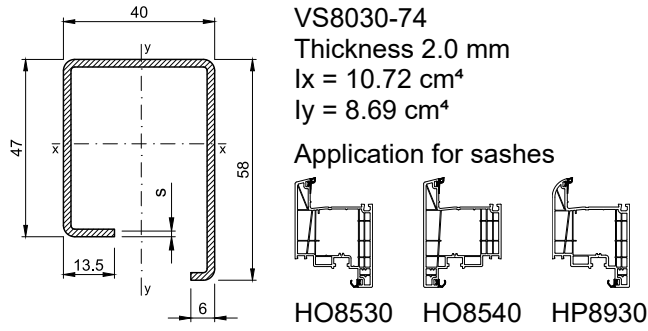

Window type 2.1 PSK doors/windows

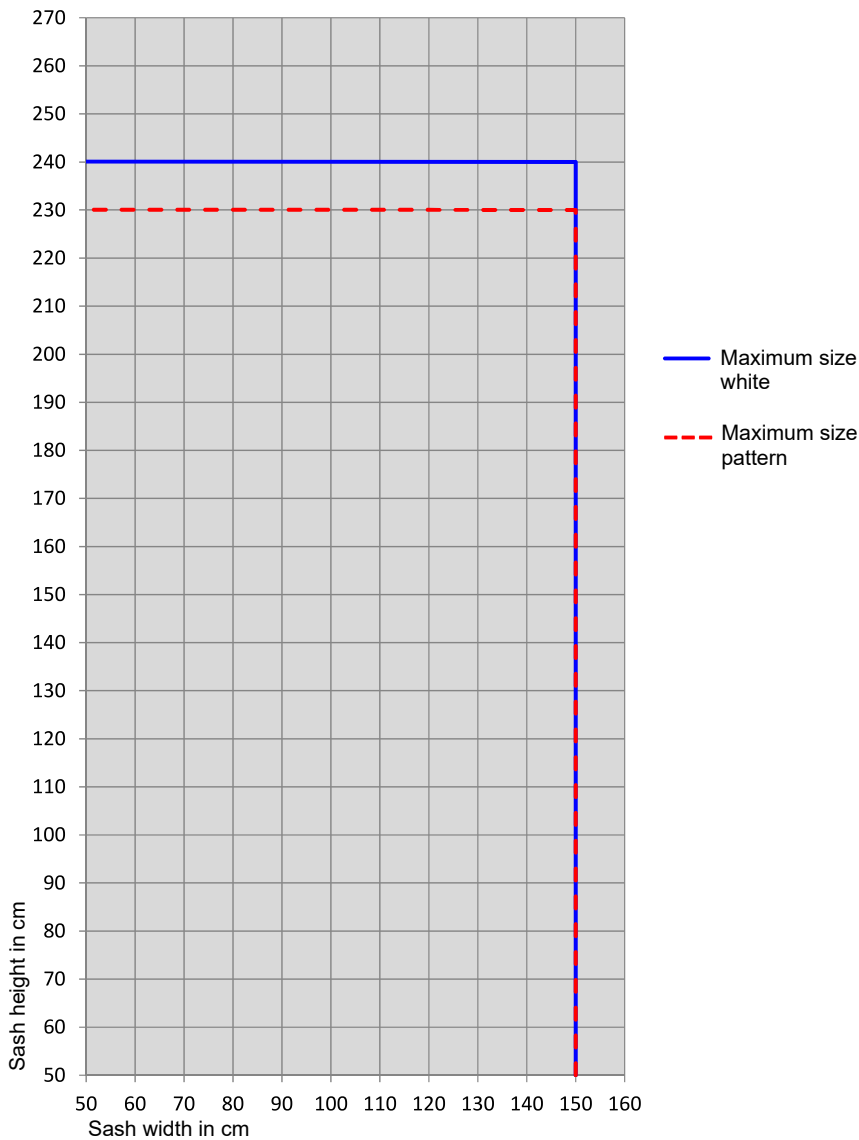
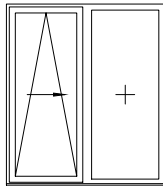

PSK door, window

**VS8450-74**

Size diagram for strengthening VS8450 2.0 mm - PSK door/window

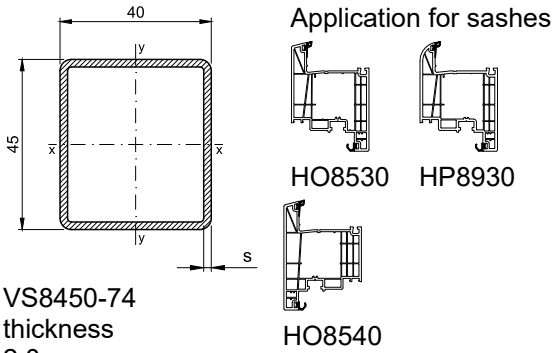

VS8450-74

thickness

2.0 mm

$l_x = 9.36 \text{ cm}^4$

$l_y = 7.80 \text{ cm}^4$

Window type 2.1 PSK doors/windows

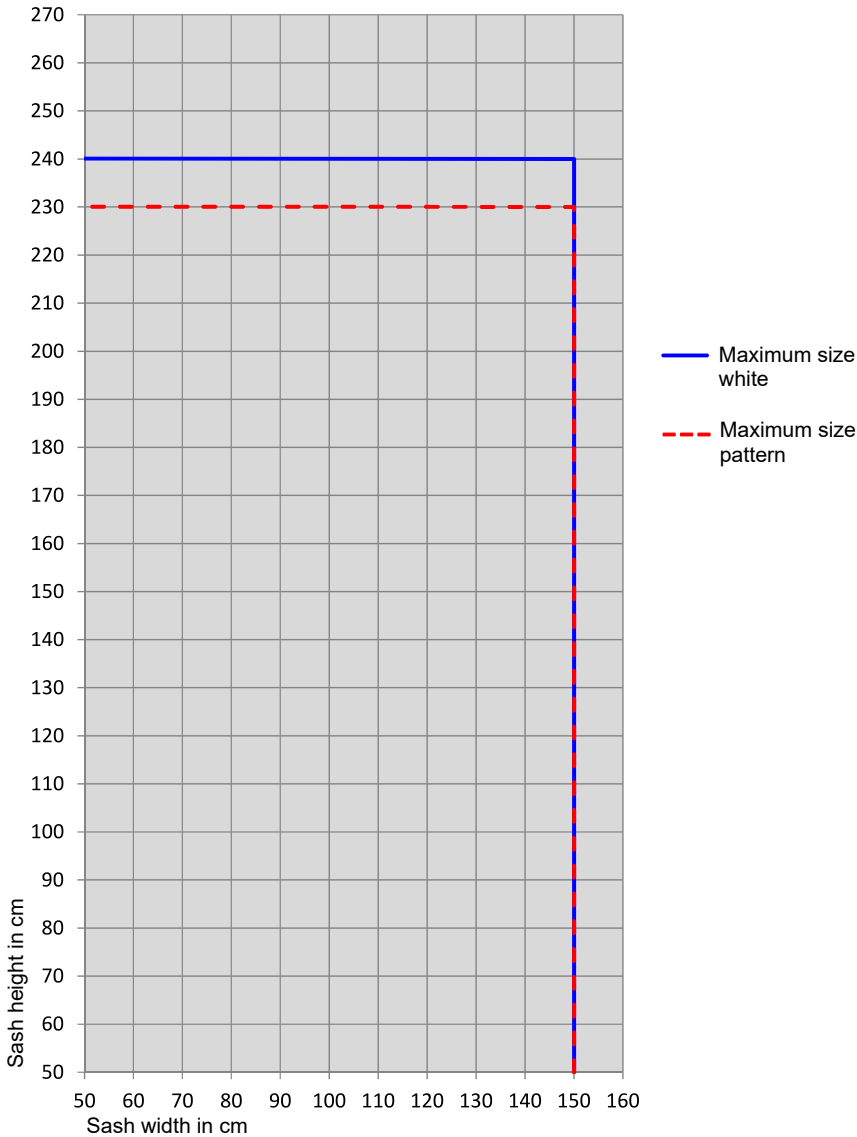
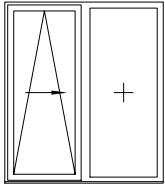

Tilt-only sash

**VS8510-73**

Size diagram for strengthening VS8510, 1.5 mm - Tilt-Only sash

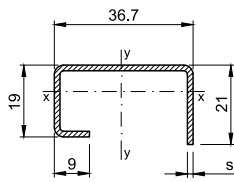

Application for sashes



HO8510

VS8510-73  
 Thickness  
 1.5 mm  
 $I_x = 0.58 \text{ cm}^4$   
 $I_y = 2.43 \text{ cm}^4$

Window type 1.1 Bottom-hung window

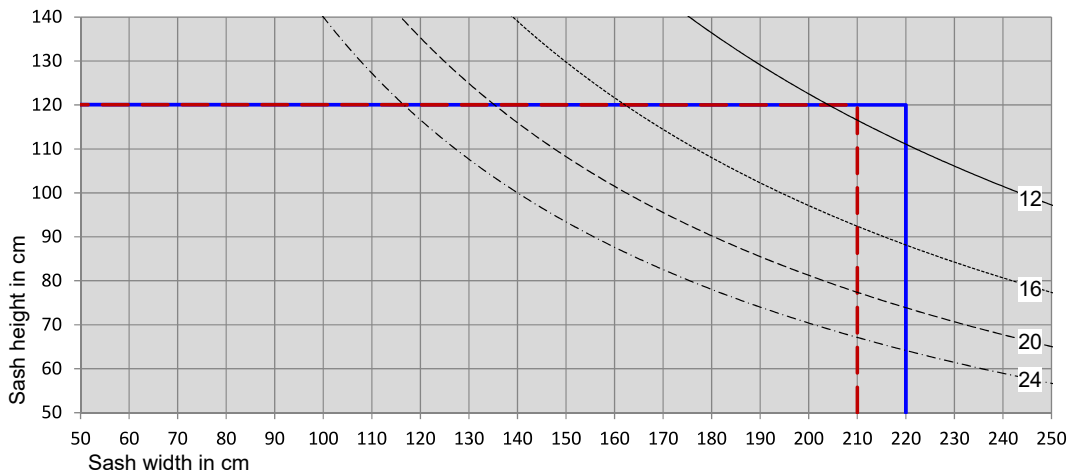
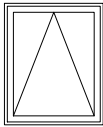

- Maximum size white
- - - Maximum size pattern
- 12 mm total glass thickness\*\*
- ..... 16 mm total glass thickness\*\*
- - - 20 mm total glass thickness\*\*
- . - . 24 mm total glass thickness\*\*

\*\*Sum of all glass panes without consideration of the gaps

Glass lines do NOT take into account the maximum permissible sash weight. Fittings must be suitable for sash size and sash weight. Further notes can be found in paragraph "Notes on sash sizes".

Tilt-only sash

**VS8510-74**

Size diagram for strengthening VS8510, 2.0 mm - Tilt-Only sash

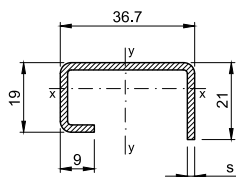

Application for sashes



HO8510

VS8510-74

Thickness

2.0 mm

$I_x = 0.72 \text{ cm}^4$

$I_y = 3.07 \text{ cm}^4$

Window type 1.1 Bottom-hung window

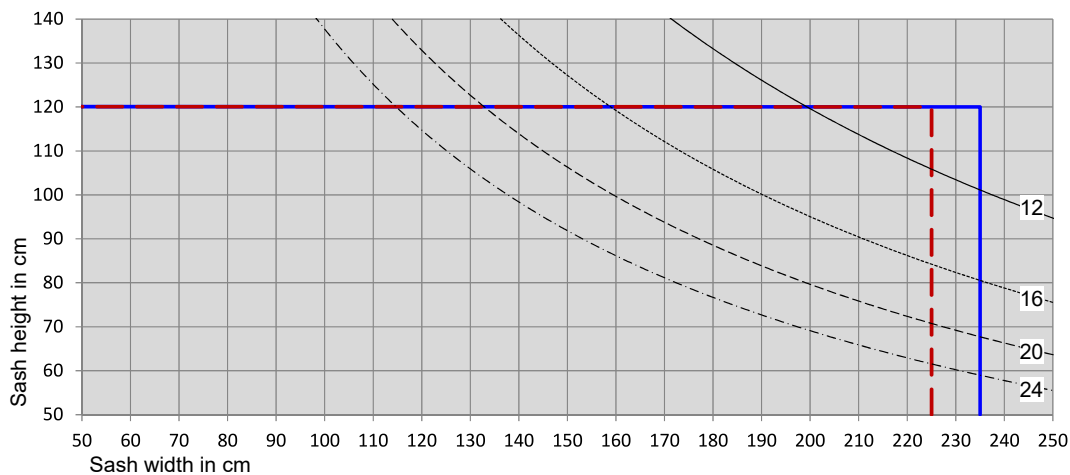
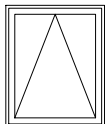

- Maximum size white
- - - Maximum size pattern
- 12 mm total glass thickness\*\*
- ..... 16 mm total glass thickness\*\*
- - - 20 mm total glass thickness\*\*
- · - · 24 mm total glass thickness\*\*

Glass lines do NOT take into account the maximum permissible sash weight. Fittings must be suitable for sash size and sash weight. Further notes can be found in paragraph "Notes on sash sizes".

\*\*Sum of all glass panes without consideration of the gaps

Tilt-only sash

**VS8020-73**

Size diagram for strengthening VS8020, 2.0 mm - Tilt-Only sash

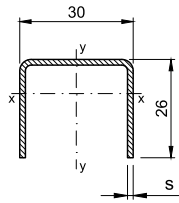

VS8020-73  
Thickness  
1.5 mm  
 $I_x = 0.82 \text{ cm}^4$   
 $I_y = 1.77 \text{ cm}^4$

Application for sashes



HO8520



HO8521



HP8920

Window type 1.1 Bottom-hung window

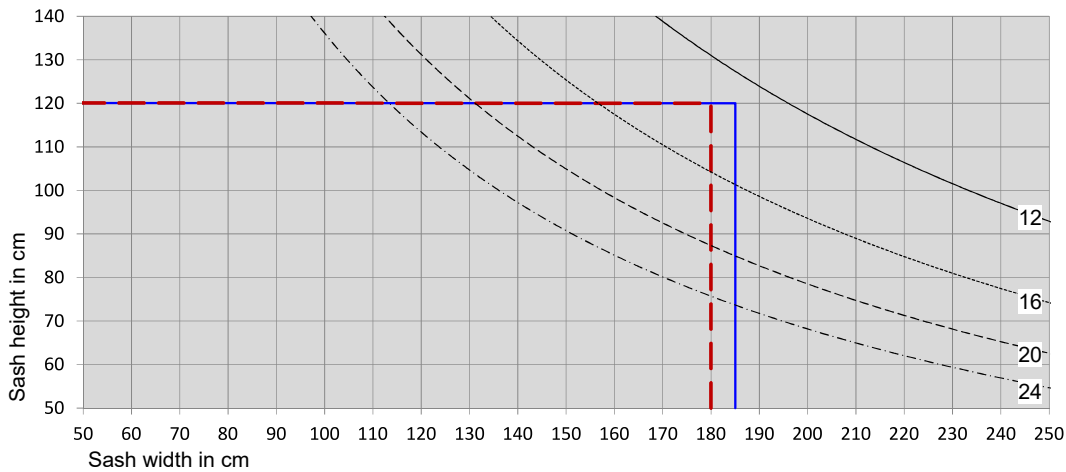
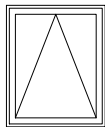

- Maximum size white
- - - Maximum size pattern
- 12 mm total glass thickness\*\*
- ..... 16 mm total glass thickness\*\*
- - - 20 mm total glass thickness\*\*
- . - . 24 mm total glass thickness\*\*

\*\*Sum of all glass panes without consideration of the gaps

Glass lines do NOT take into account the maximum permissible sash weight. Fittings must be suitable for sash size and sash weight. Further notes can be found in paragraph "Notes on sash sizes".

Tilt-only sash

**VS8020-74**

Size diagram for strengthening VS8020, 2.0 mm - Tilt-Only sash

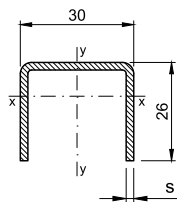

Application for sashes



HO8520



HO8521



HP8920

VS8020-74

Thickness

2.0 mm

$I_x = 1.06 \text{ cm}^4$

$I_y = 2.26 \text{ cm}^4$

Window type 1.1 Bottom-hung window

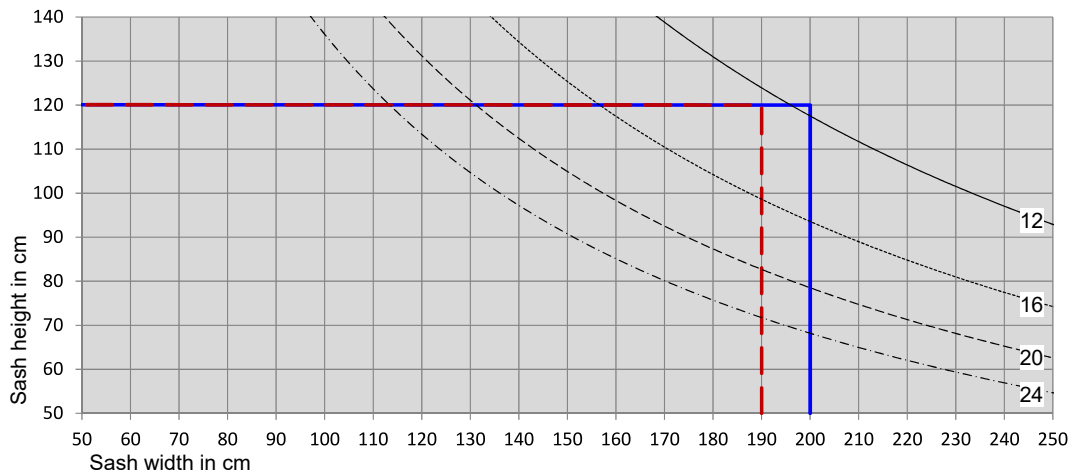
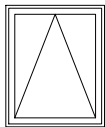

- Maximum size white
- - - Maximum size pattern
- 12 mm total glass thickness\*\*
- - - - 16 mm total glass thickness\*\*
- - - - 20 mm total glass thickness\*\*
- - - - 24 mm total glass thickness\*\*

\*\*Sum of all glass panes without consideration of the gaps

Glass lines do NOT take into account the maximum permissible sash weight. Fittings must be suitable for sash size and sash weight. Further notes can be found in paragraph "Notes on sash sizes".

Tilt-only sash

**VS8050-74**

Size diagram for strengthening VS8050, 2.0 mm - Tilt-Only sash

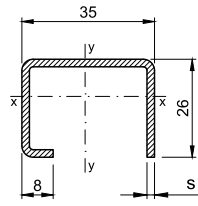

VS8050-74  
Thickness  
2.0 mm  
 $lx = 1.40 \text{ cm}^4$   
 $ly = 3.41 \text{ cm}^4$

Application for sashes



HO8520



HO8521



HP8920

Window type 1.1 Bottom-hung window

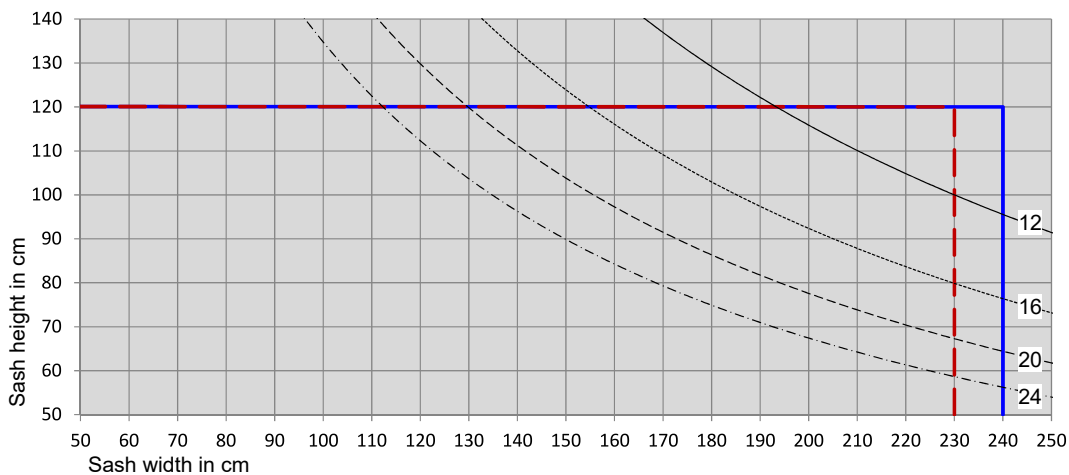
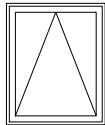

- Maximum size white
- - - Maximum size pattern
- 12 mm total glass thickness\*\*
- ..... 16 mm total glass thickness\*\*
- - - 20 mm total glass thickness\*\*
- · - · - 24 mm total glass thickness\*\*

\*\*Sum of all glass panes without consideration of the gaps

Glass lines do NOT take into account the maximum permissible sash weight. Fittings must be suitable for sash size and sash weight. Further notes can be found in paragraph "Notes on sash sizes".

Tilt-only sash

VS8055-75

Size diagram for strengthening VS8055, 2.5 mm - Tilt-Only sash

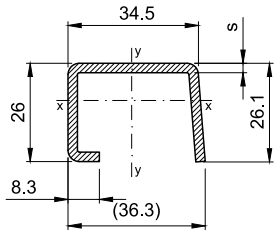

VS8055-75  
 Thickness  
 2.5 mm  
 $I_x = 1.65 \text{ cm}^4$   
 $I_y = 4.09 \text{ cm}^4$

Application for sashes



HO8520



HO8521



HP8920

Window type 1.1 Bottom-hung window

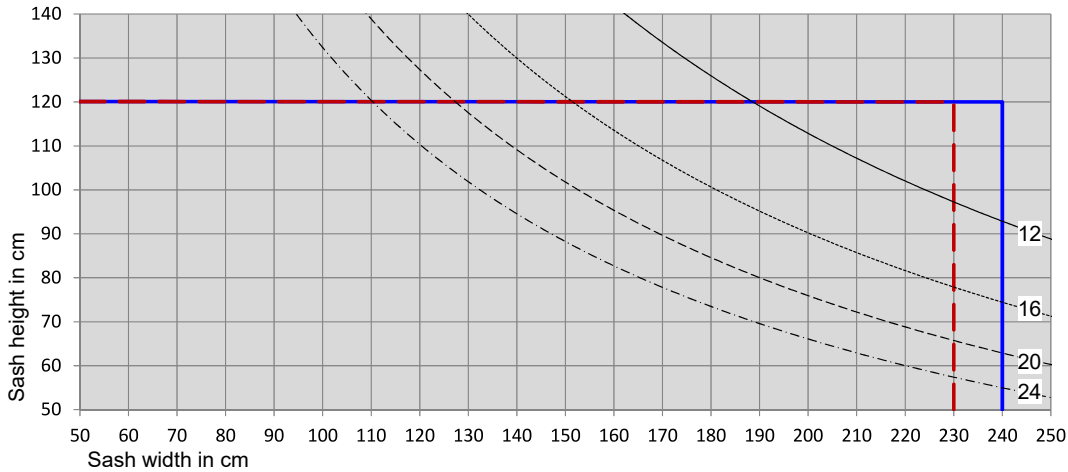
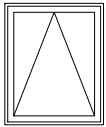

- Maximum size white
- - - Maximum size pattern
- 12 mm total glass thickness\*\*
- ..... 16 mm total glass thickness\*\*
- - - 20 mm total glass thickness\*\*
- · - · 24 mm total glass thickness\*\*

\*\*Sum of all glass panes without consideration of the gaps

Glass lines do NOT take into account the maximum permissible sash weight. Fittings must be suitable for sash size and sash weight. Further notes can be found in paragraph "Notes on sash sizes".

Tilt-only sash

**VS8520-73**

Size diagram for strengthening VS8520, 1.5 mm - Tilt-Only sash

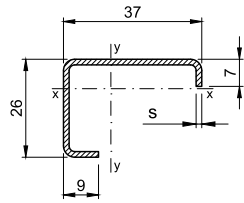

VS8520-73  
Thickness  
1.5 mm  
 $I_x = 0.89 \text{ cm}^4$   
 $I_y = 1.72 \text{ cm}^4$

Application for sashes



HO8520



HO8521



HP8920

Window type 1.1 Bottom-hung window

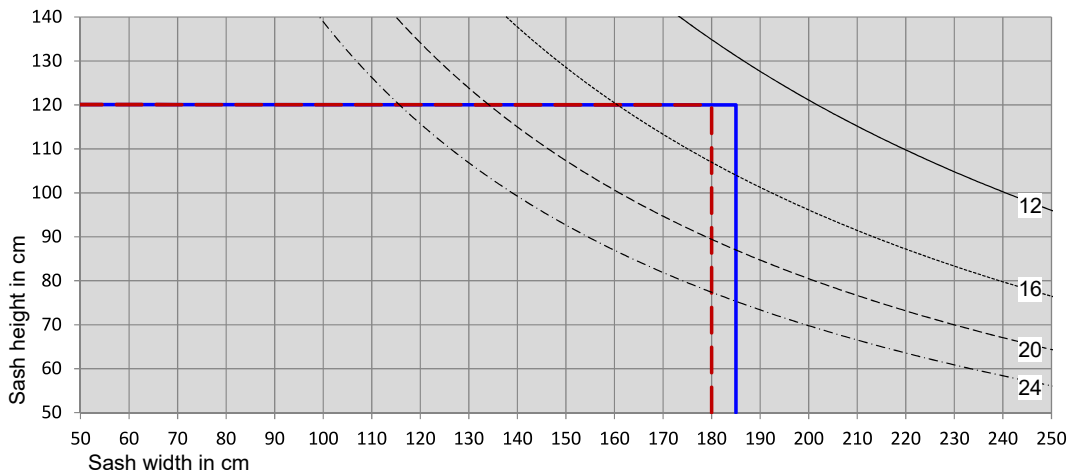
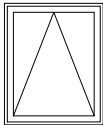

- Maximum size white
- - - Maximum size pattern
- 12 mm total glass thickness\*\*
- ..... 16 mm total glass thickness\*\*
- - - 20 mm total glass thickness\*\*
- . - . 24 mm total glass thickness\*\*

\*\*Sum of all glass panes without consideration of the gaps

Glass lines do NOT take into account the maximum permissible sash weight. Fittings must be suitable for sash size and sash weight. Further notes can be found in paragraph "Notes on sash sizes".

Tilt-only sash

**VS8620-74**

Size diagram for strengthening VS8620, 2.0 mm - Tilt-Only sash

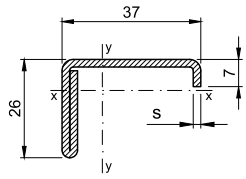

VS8620-74  
Thickness  
2.0 mm  
 $I_x = 1.11 \text{ cm}^4$   
 $I_y = 2.48 \text{ cm}^4$

Application for sashes



HO8520



HO8521



HP8920

Window type 1.1 Bottom-hung window

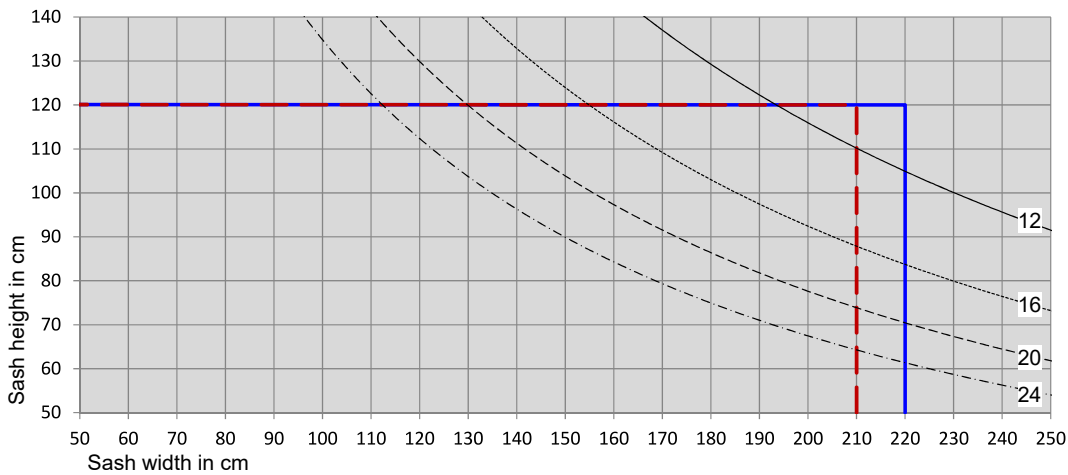
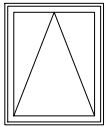

- Maximum size white
- - - Maximum size pattern
- 12 mm total glass thickness\*\*
- ..... 16 mm total glass thickness\*\*
- - - 20 mm total glass thickness\*\*
- · - · 24 mm total glass thickness\*\*

\*\*Sum of all glass panes without consideration of the gaps

Glass lines do NOT take into account the maximum permissible sash weight. Fittings must be suitable for sash size and sash weight. Further notes can be found in paragraph "Notes on sash sizes".

Tilt-only sash

**VS8030-73**

Size diagram for strengthening VS8030, 1.5 mm - Tilt-Only sash

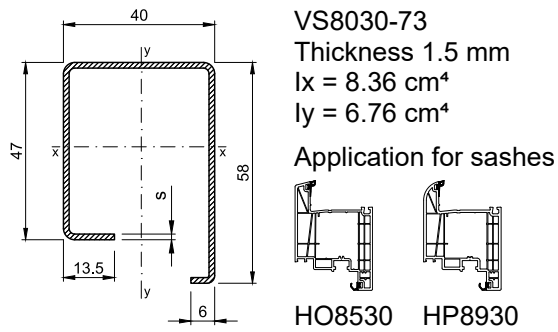

Window type 1.1 Bottom-hung window

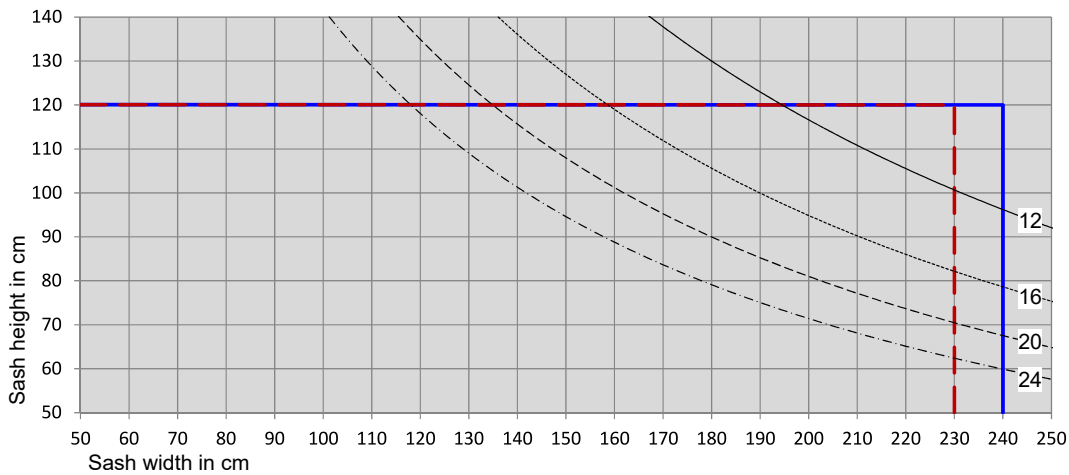
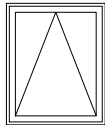

- Maximum size white
- - - Maximum size pattern
- 12 mm total glass thickness\*\*
- ..... 16 mm total glass thickness\*\*
- - - 20 mm total glass thickness\*\*
- · - · - 24 mm total glass thickness\*\*

\*\*Sum of all glass panes without consideration of the gaps

Glass lines do NOT take into account the maximum permissible sash weight. Fittings must be suitable for sash size and sash weight. Further notes can be found in paragraph "Notes on sash sizes".

Tilt-only sash

**VS8030-74**

Size diagram for strengthening VS8030, 2.0 mm - Tilt-Only sash

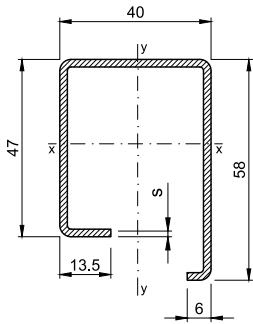

VS8030-74  
 Thickness 2.0 mm  
 $I_x = 10.72 \text{ cm}^4$   
 $I_y = 8.69 \text{ cm}^4$

Application for sashes

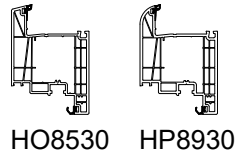

Window type 1.1 Bottom-hung window

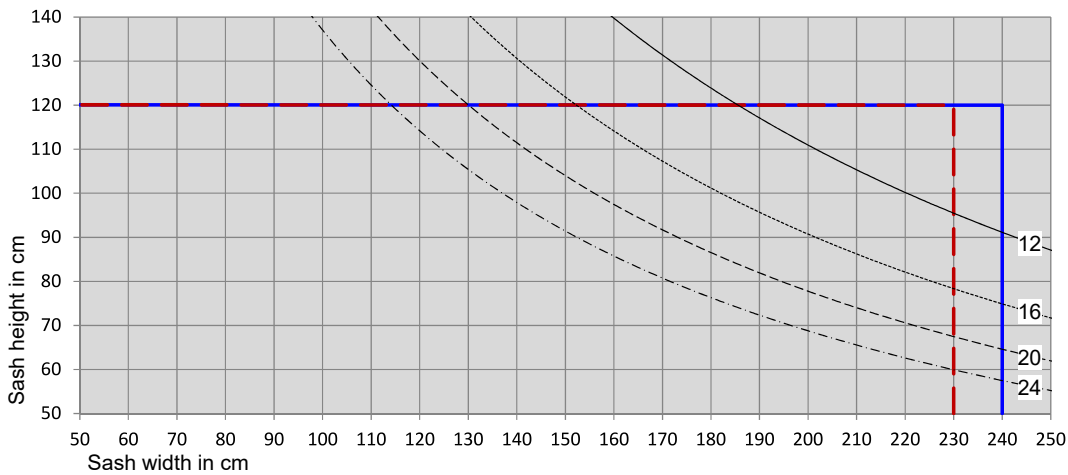
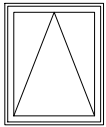

- Maximum size white
- - - Maximum size pattern
- 12 mm total glass thickness\*\*
- ..... 16 mm total glass thickness\*\*
- - - 20 mm total glass thickness\*\*
- · - 24 mm total glass thickness\*\*

\*\*Sum of all glass panes without consideration of the gaps

Glass lines do NOT take into account the maximum permissible sash weight. Fittings must be suitable for sash size and sash weight. Further notes can be found in paragraph "Notes on sash sizes".

Tilt-only sash

**VS8450-74**

Size diagram for strengthening VS8450, 2.0 mm - Tilt-Only sash

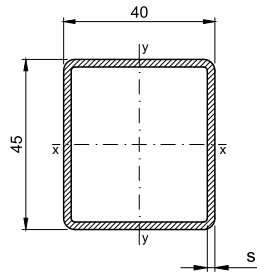

Application for sashes

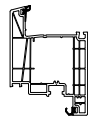

HO8530

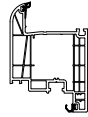

HP8930

VS8450-74  
thickness  
2.0 mm  
 $I_x = 9.36 \text{ cm}^4$   
 $I_y = 7.80 \text{ cm}^4$

Window type 1.1 Bottom-hung window

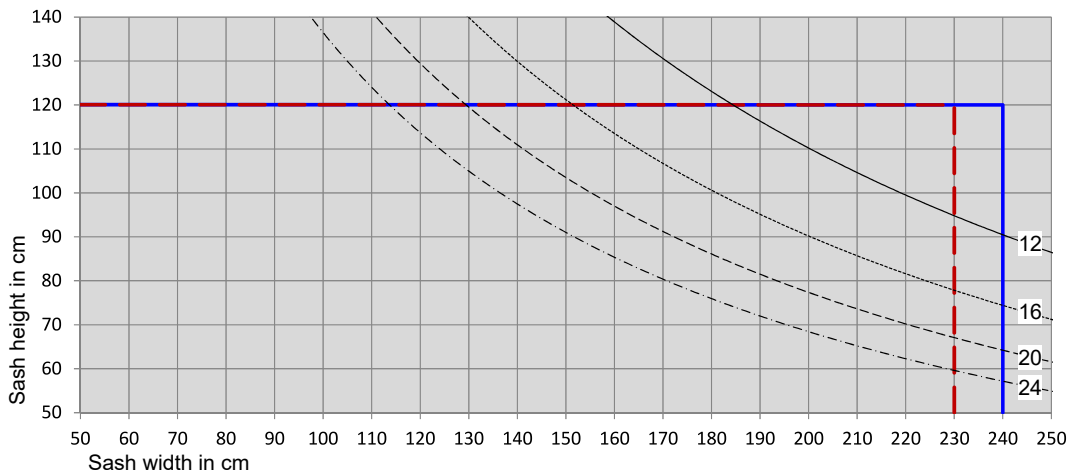
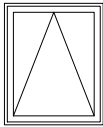

- Maximum size white
- - - Maximum size pattern
- 12 mm total glass thickness\*\*
- ..... 16 mm total glass thickness\*\*
- - - 20 mm total glass thickness\*\*
- - - 24 mm total glass thickness\*\*

\*\*Sum of all glass panes without consideration of the gaps

Glass lines do NOT take into account the maximum permissible sash weight. Fittings must be suitable for sash size and sash weight. Further notes can be found in paragraph "Notes on sash sizes".

French window sash

VS8520-73

Size diagram for strengthening VS8520, 1.5 mm - French window sash

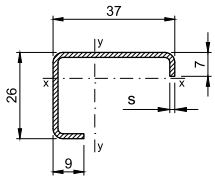

Application for French window sash



HO8570

VS8520-73  
Thickness  
1.5 mm  
 $I_x = 0.89 \text{ cm}^4$   
 $I_y = 1.72 \text{ cm}^4$

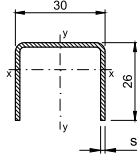

Application for sashes



HO8520

VS8020-73  
Thickness  
1.5 mm  
 $I_x = 0.82 \text{ cm}^4$   
 $I_y = 1.77 \text{ cm}^4$

Window type 1.2 Turn-only / bottom-hung window/door

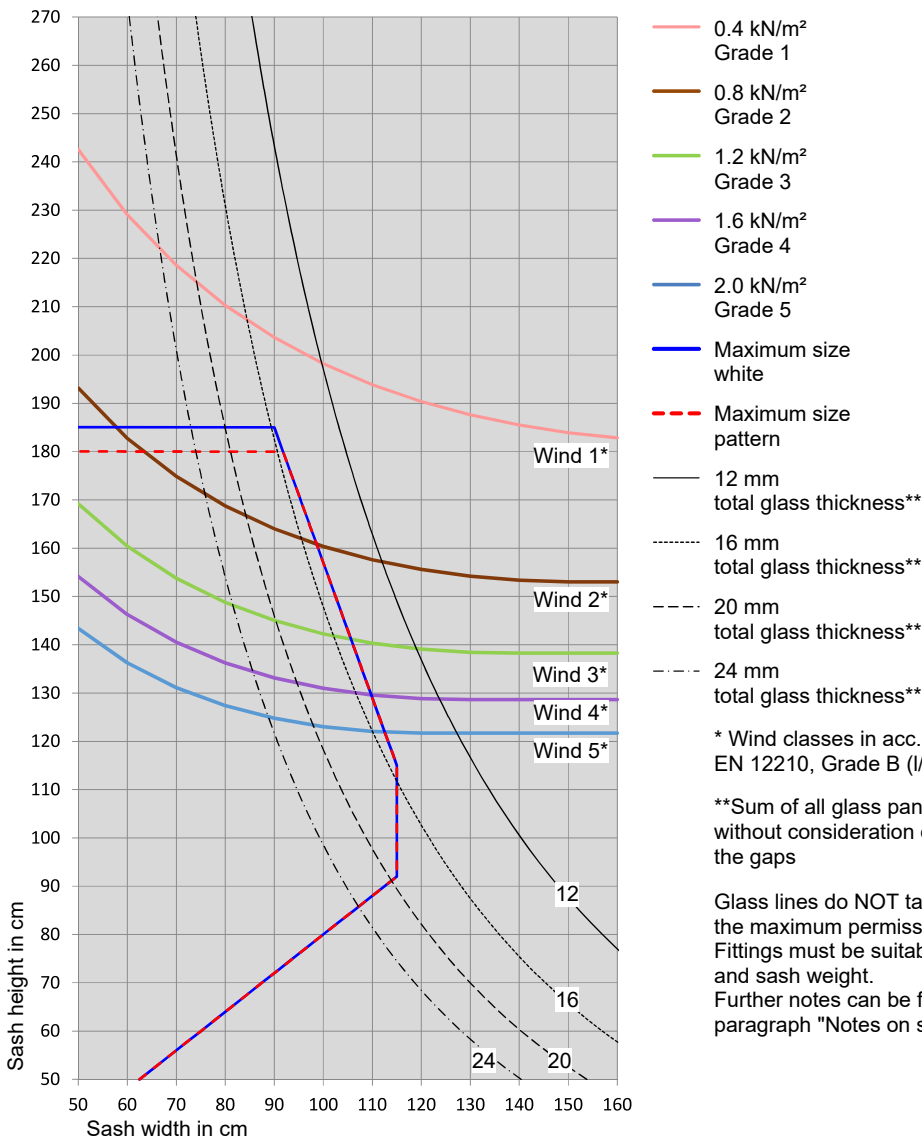
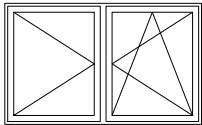

French window sash

**VS8520-73**

Size diagram for strengthening VS8520, 1.5 mm - French window sash

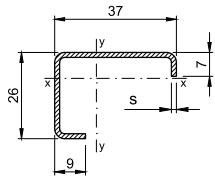

Application for French window sash

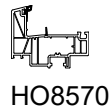

VS8520-73  
Thickness  
1.5 mm  
 $I_x = 0.89 \text{ cm}^4$   
 $I_y = 1.72 \text{ cm}^4$

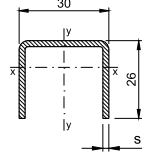

Application for sashes



VS8020-74  
Thickness  
2.0 mm  
 $I_x = 1.06 \text{ cm}^4$   
 $I_y = 2.26 \text{ cm}^4$

Window type 1.2 Turn-only / bottom-hung window/door

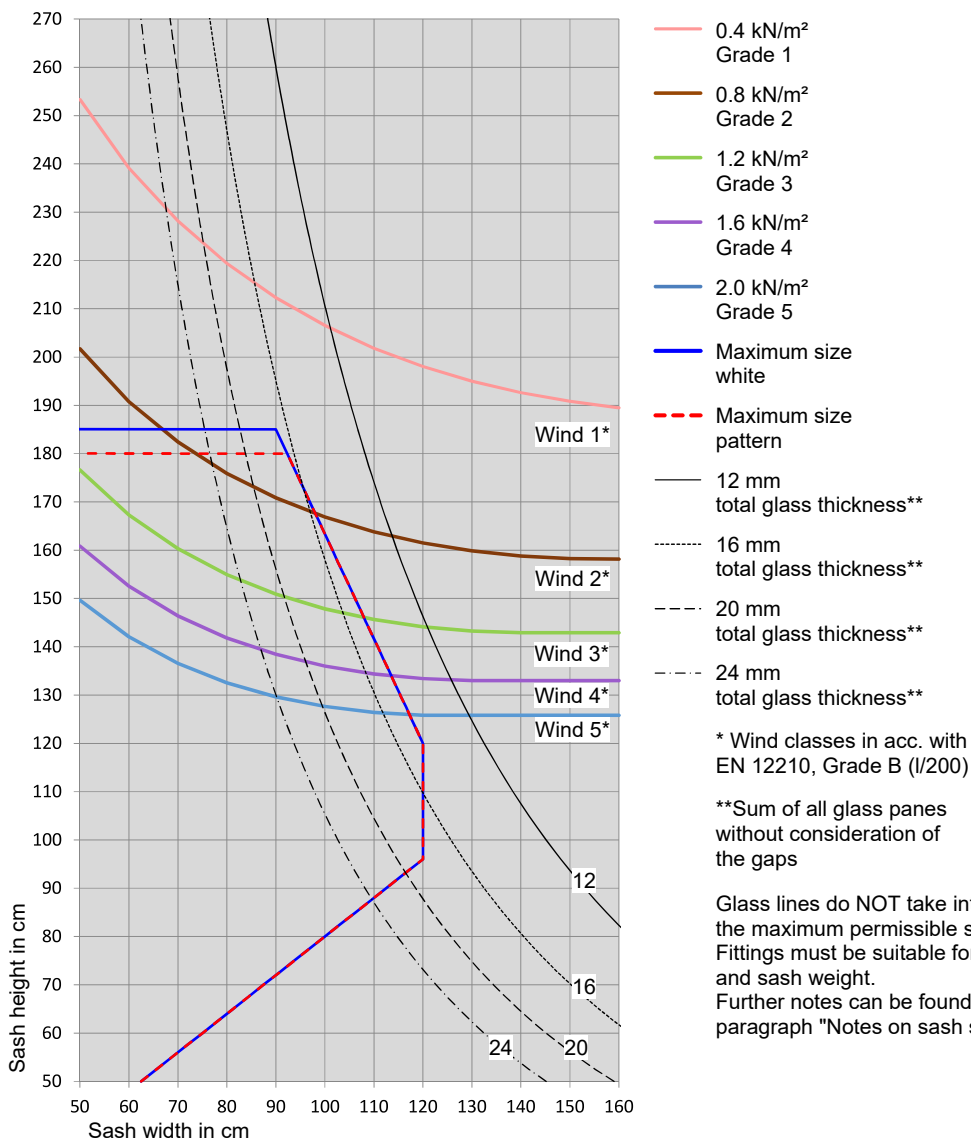
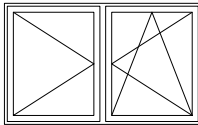

French window sash

VS8520-73

Size diagram for strengthening VS8520, 1.5 mm - French window sash

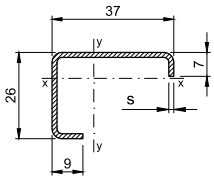

Application for French window sash



HO8570

VS8520-73  
Thickness  
1.5 mm  
 $I_x = 0.89 \text{ cm}^4$   
 $I_y = 1.72 \text{ cm}^4$

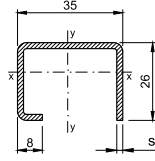

Application for sashes



HO8520

VS8050-74  
Thickness  
2.0 mm  
 $I_x = 1.40 \text{ cm}^4$   
 $I_y = 3.41 \text{ cm}^4$

Window type 1.2 Turn-only / bottom-hung window/door

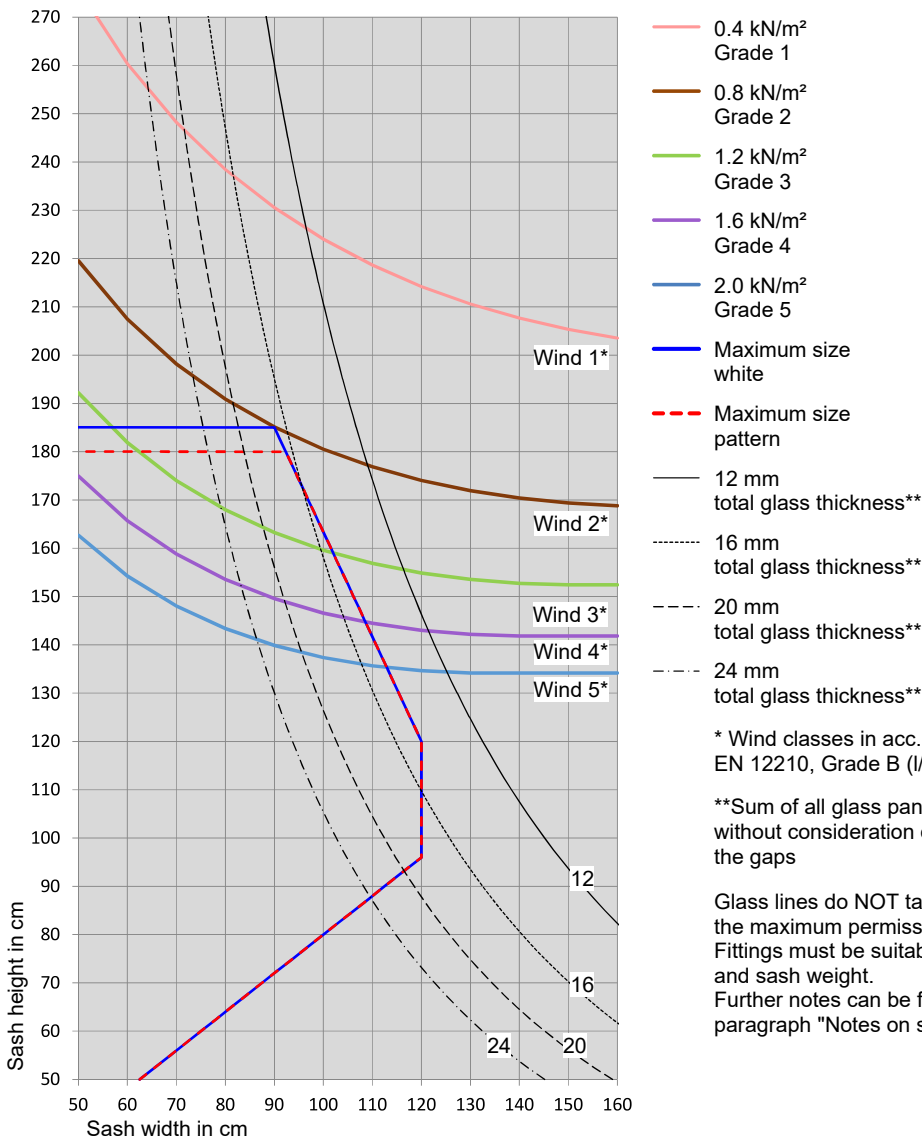
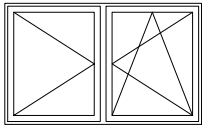

\* Wind classes in acc. with EN 12210, Grade B (I/200)

\*\*Sum of all glass panes without consideration of the gaps

Glass lines do NOT take into account the maximum permissible sash weight. Fittings must be suitable for sash size and sash weight. Further notes can be found in paragraph "Notes on sash sizes".

French window sash

**VS8520-73**

Size diagram for strengthening VS8520, 1.5 mm - French window sash

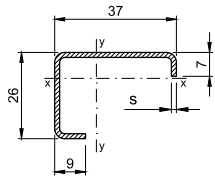

Application for French window sash

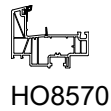

**VS8520-73**  
 Thickness  
 1.5 mm  
 $l_x = 0.89 \text{ cm}^4$   
 $l_y = 1.72 \text{ cm}^4$

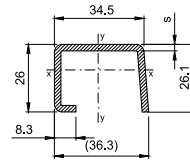

Application for sashes



**VS8055-75**  
 Thickness  
 2.5 mm  
 $l_x = 1.65 \text{ cm}^4$   
 $l_y = 4.09 \text{ cm}^4$

Window type 1.2 Turn-only / bottom-hung window/door

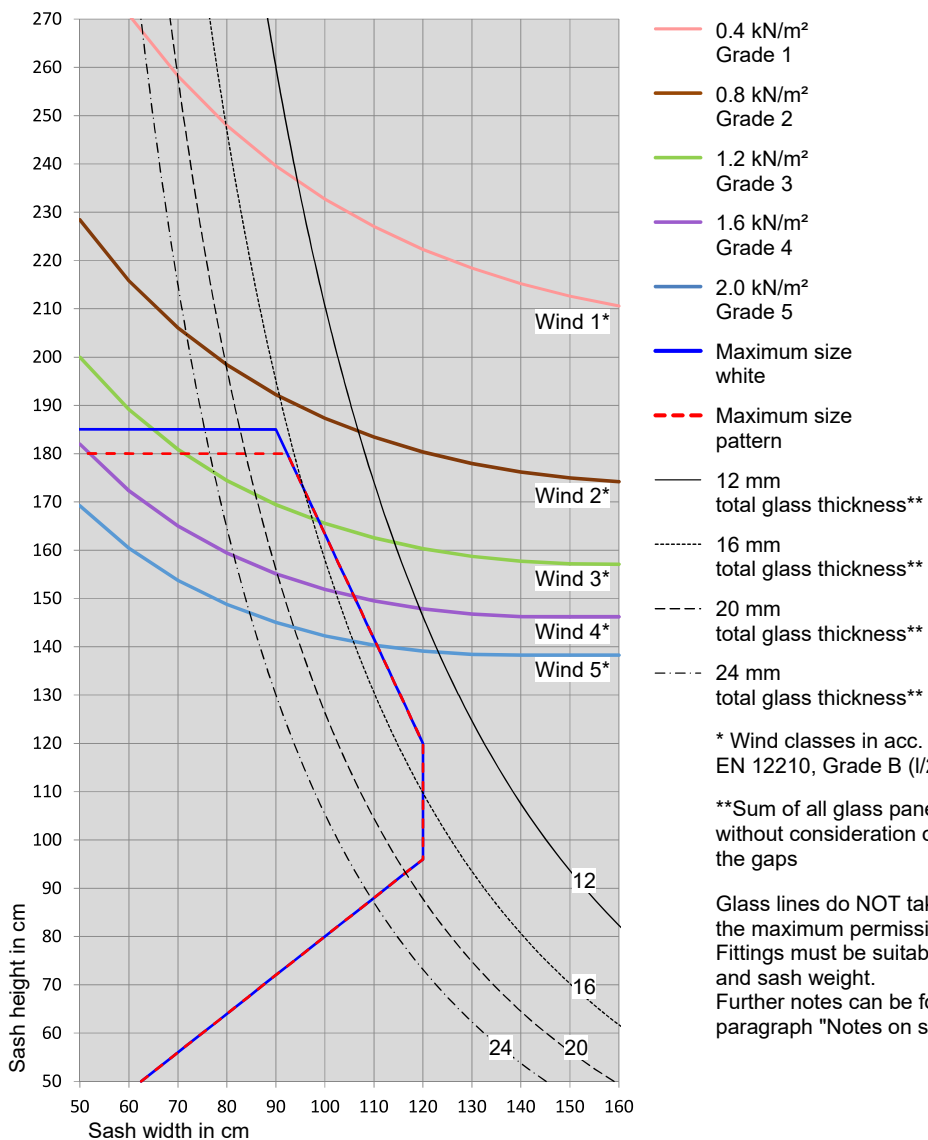
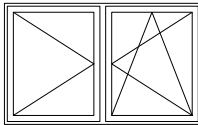

French window sash

VS8520-73

Size diagram for strengthening VS8520, 1.5 mm - French window sash

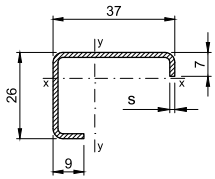

Application for French window sash



HO8570

VS8520-73  
Thickness  
1.5 mm  
 $I_x = 0.89 \text{ cm}^4$   
 $I_y = 1.72 \text{ cm}^4$

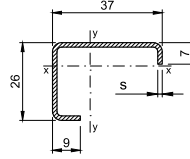

Application for sashes



HO8520

VS8520-73  
Thickness  
1.5 mm  
 $I_x = 0.89 \text{ cm}^4$   
 $I_y = 1.72 \text{ cm}^4$

Window type 1.2 Turn-only / bottom-hung window/door

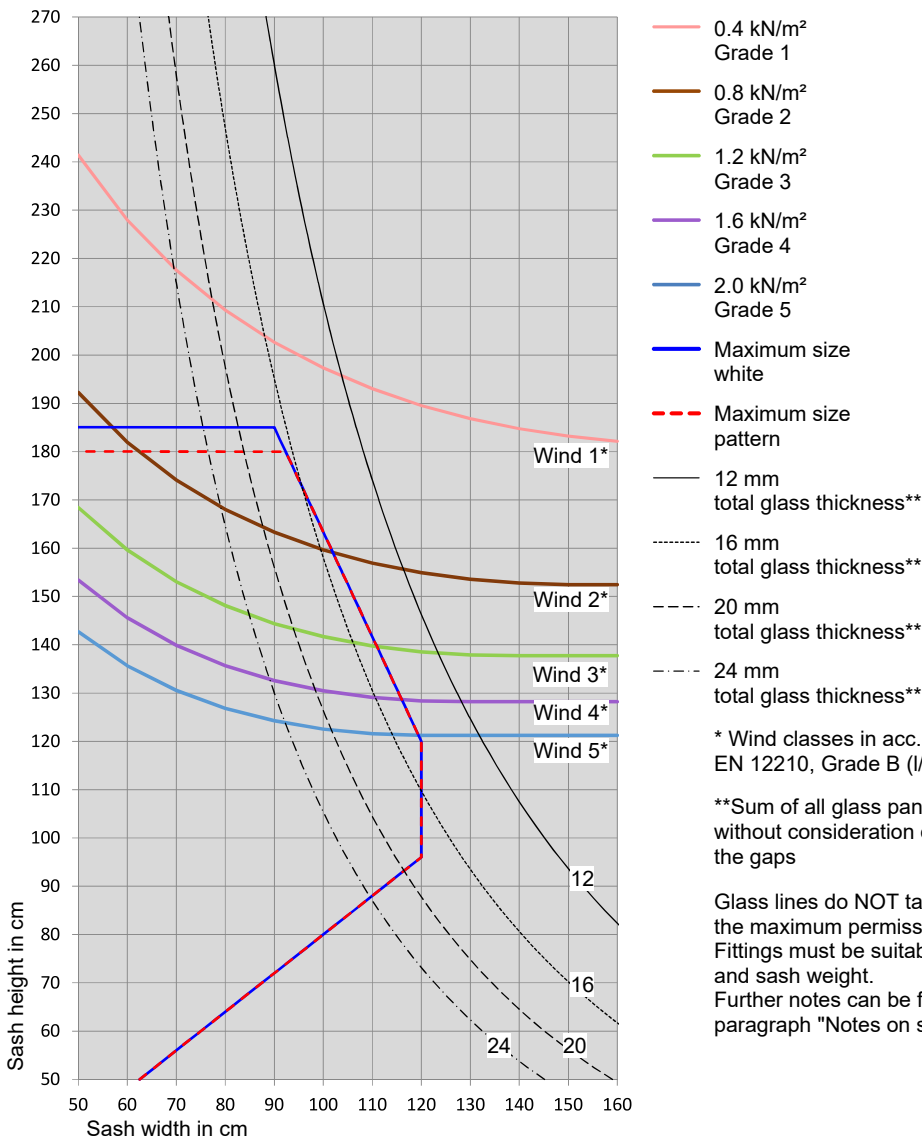
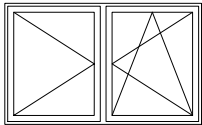

French window sash

**VS8520-73**

Size diagram for strengthening VS8520, 1.5 mm - French window sash

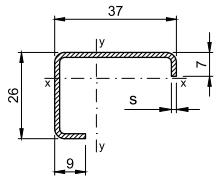

Application for French window sash

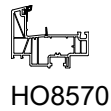

VS8520-73  
Thickness  
1.5 mm  
 $I_x = 0.89 \text{ cm}^4$   
 $I_y = 1.72 \text{ cm}^4$

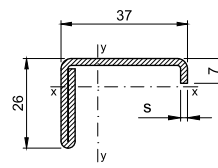

Application for sashes



VS8620-74  
Thickness  
2.0 mm  
 $I_x = 1.11 \text{ cm}^4$   
 $I_y = 2.48 \text{ cm}^4$

Window type 1.2 Turn-only / bottom-hung window/door

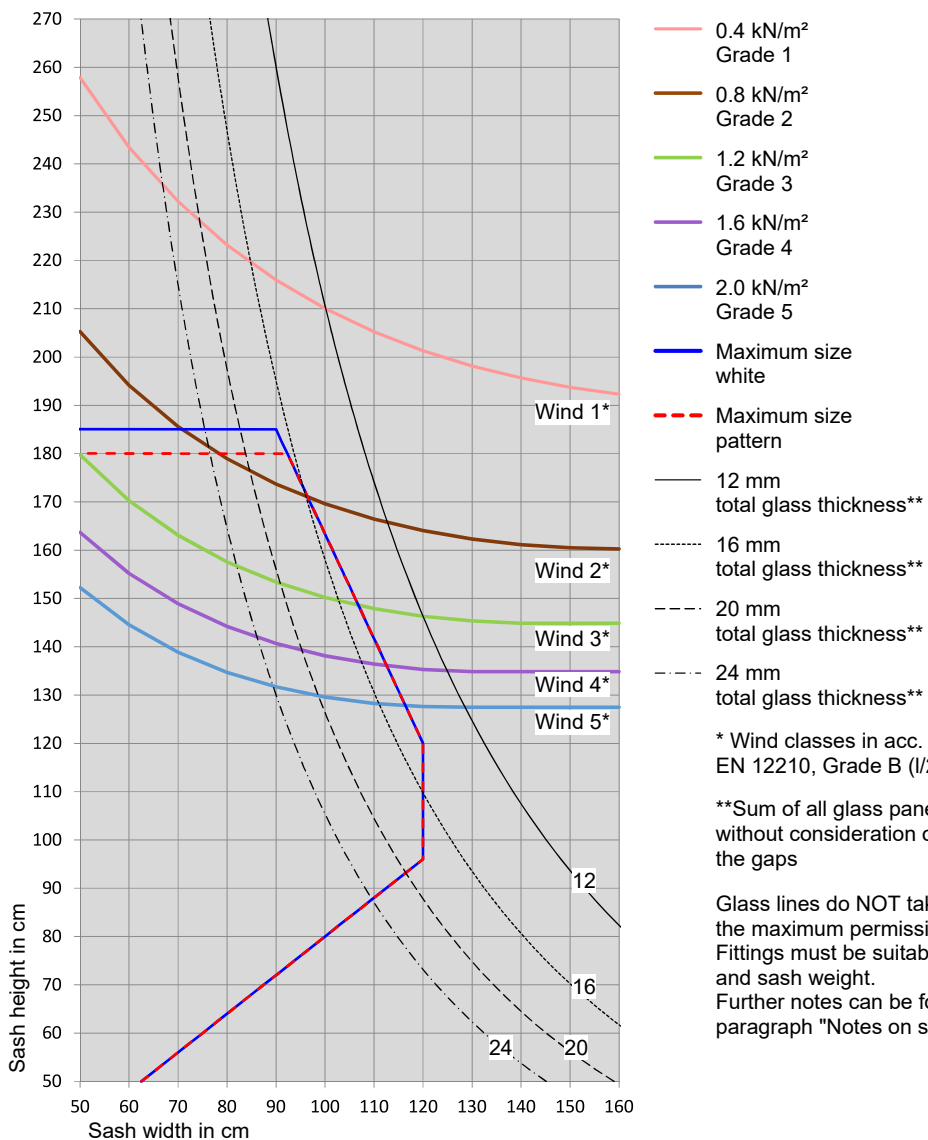
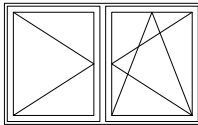

French window sash

VS8520-73

Size diagram for strengthening VS8520, 1.5 mm - French window sash

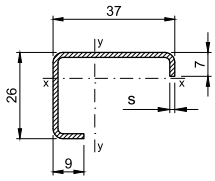

Application for French window sash



HO8570

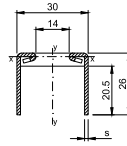

Application for sashes



HO8520

VS8520-73

Thickness

1.5 mm

$I_x = 0.89 \text{ cm}^4$

$I_y = 1.72 \text{ cm}^4$

VS9029

Thickness

1.5 mm

$I_x = 0.74 \text{ cm}^4$

$I_y = 1.90 \text{ cm}^4$

Window type 1.2 Turn-only / bottom-hung window/door

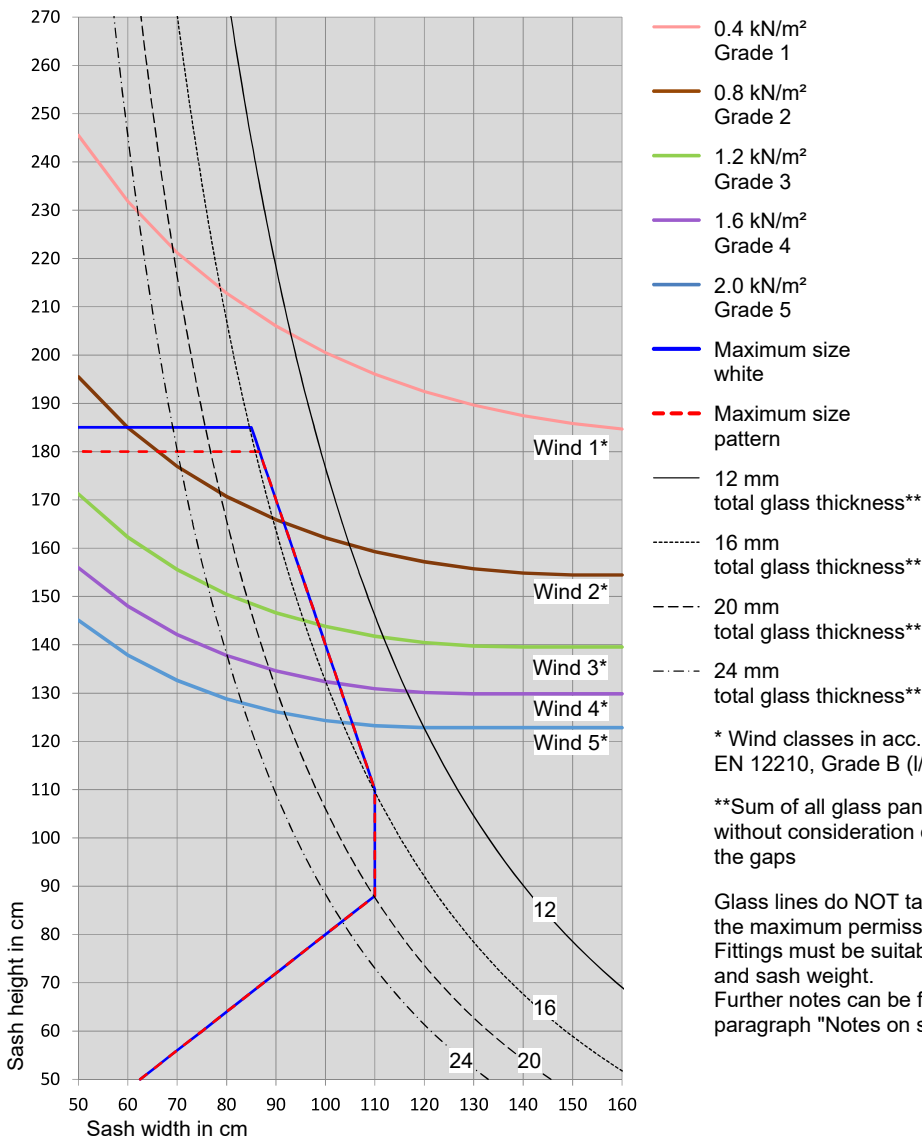
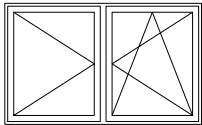

French window sash

**VS8620-74**

Size diagram for strengthening VS8620, 2.0 mm - French window sash

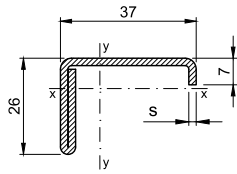

Application for French window sash

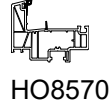

HO8570

VS8620-74  
Thickness  
2.0 mm  
 $I_x = 1.11 \text{ cm}^4$   
 $I_y = 2.48 \text{ cm}^4$

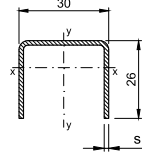

Application for sashes



HO8520

VS8020-73  
Thickness  
1.5 mm  
 $I_x = 0.82 \text{ cm}^4$   
 $I_y = 1.77 \text{ cm}^4$

Window type 1.2 Turn-only / bottom-hung window/door

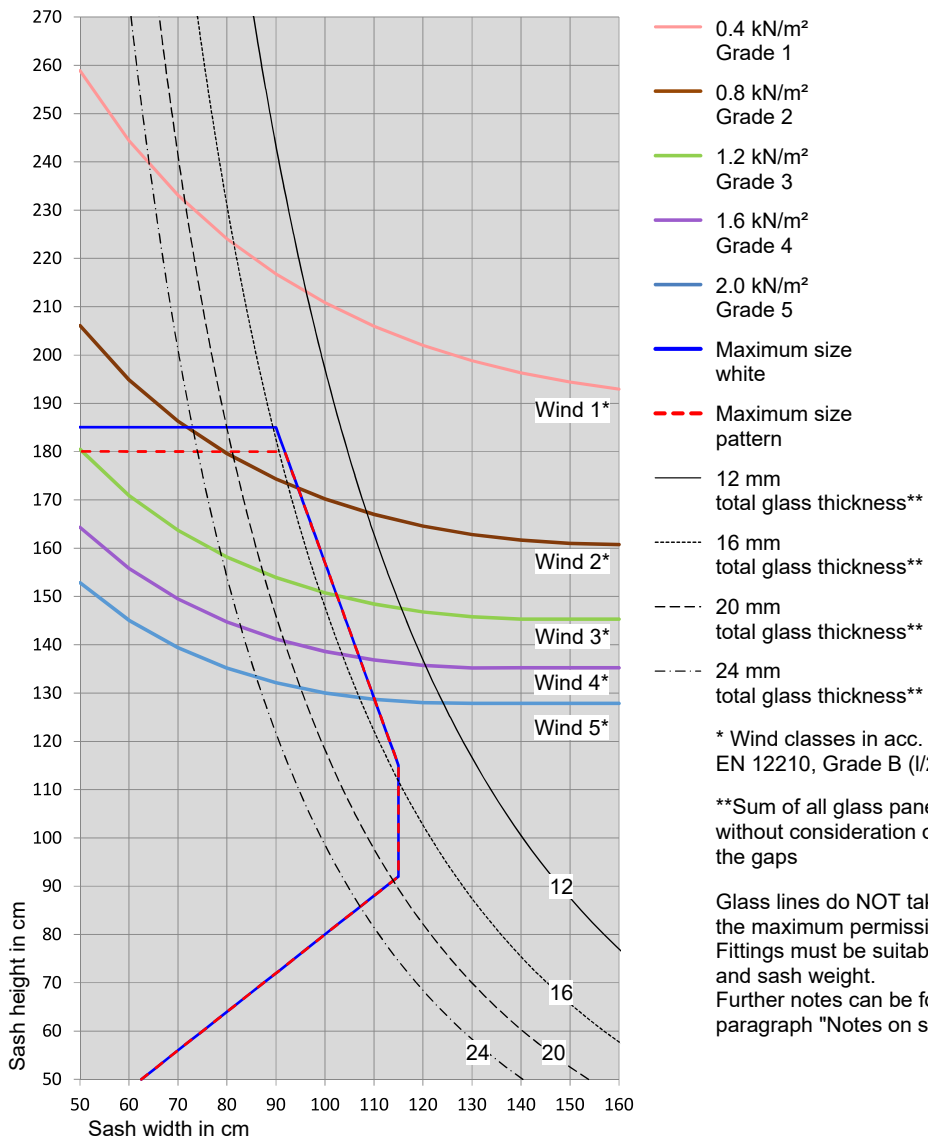
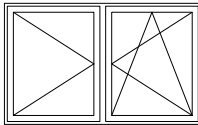

French window sash

VS8620-74

Size diagram for strengthening VS8620, 2.0 mm - French window sash

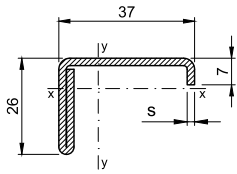

Application for French window sash

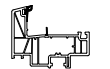

HO8570

VS8620-74  
Thickness  
2.0 mm  
 $I_x = 1.11 \text{ cm}^4$   
 $I_y = 2.48 \text{ cm}^4$

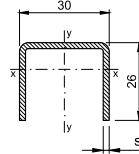

Application for sashes



HO8520

VS8020-74  
Thickness  
2.0 mm  
 $I_x = 1.06 \text{ cm}^4$   
 $I_y = 2.26 \text{ cm}^4$

Window type 1.2 Turn-only / bottom-hung window/door

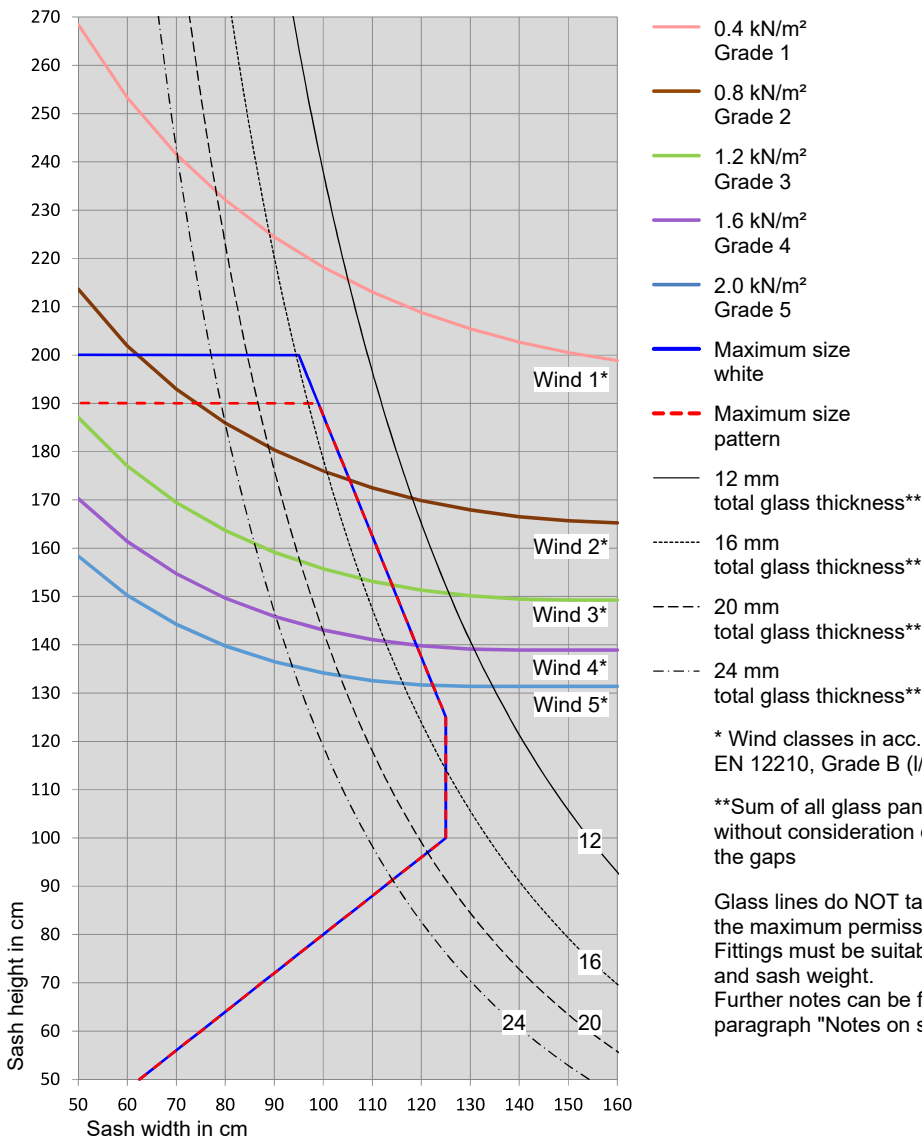
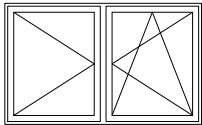

French window sash

**VS8620-74**

Size diagram for strengthening VS8620, 2.0 mm - French window sash

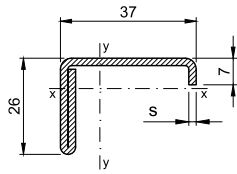

Application for French window sash



HO8570

VS8620-74  
Thickness  
2.0 mm  
 $lx = 1.11 \text{ cm}^4$   
 $ly = 2.48 \text{ cm}^4$

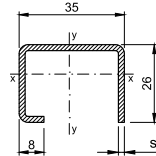

Application for sashes



HO8520

VS8050-74  
Thickness  
2.0 mm  
 $lx = 1.40 \text{ cm}^4$   
 $ly = 3.41 \text{ cm}^4$

Window type 1.2 Turn-only / bottom-hung window/door

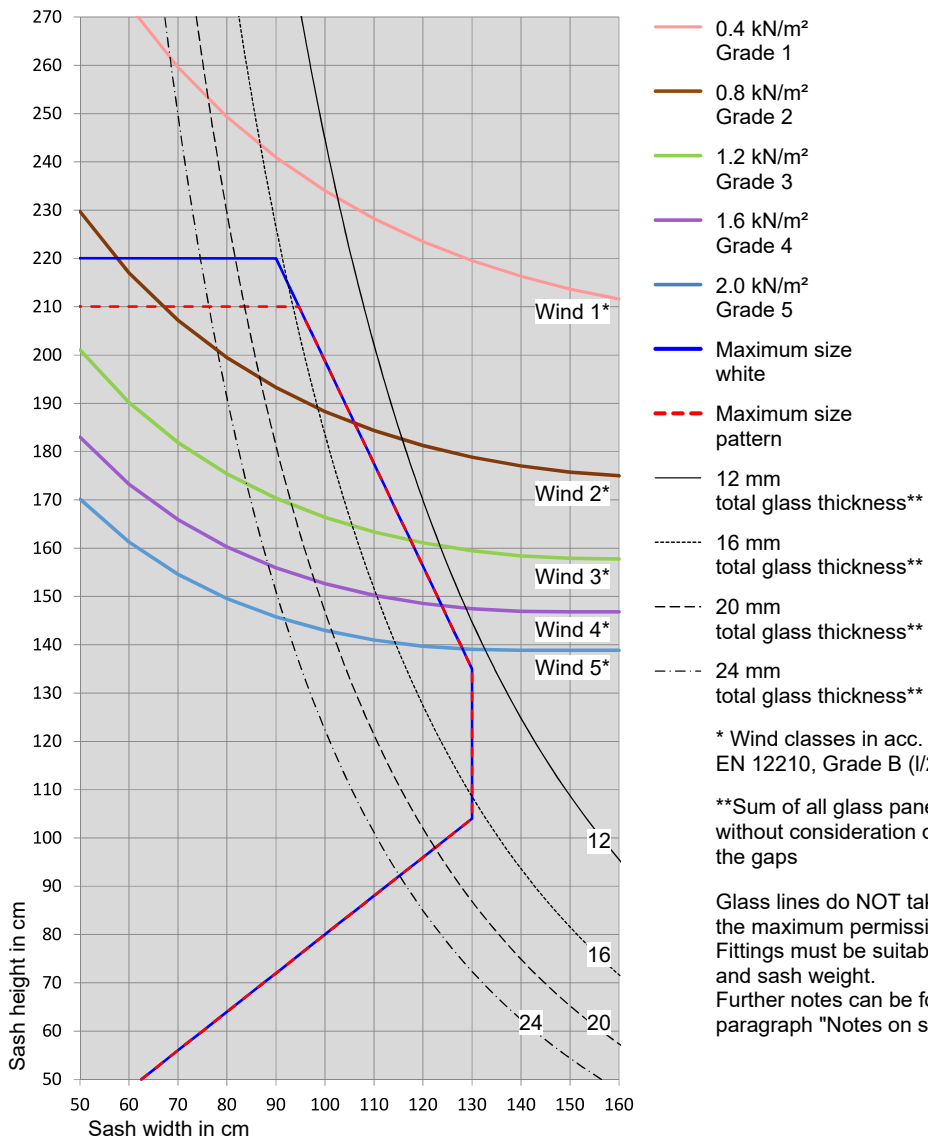
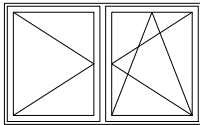

\* Wind classes in acc. with EN 12210, Grade B (I/200)

\*\*Sum of all glass panes without consideration of the gaps

Glass lines do NOT take into account the maximum permissible sash weight. Fittings must be suitable for sash size and sash weight. Further notes can be found in paragraph "Notes on sash sizes".

French window sash

VS8620-74

Size diagram for strengthening VS8620, 2.0 mm - French window sash

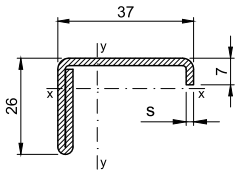

Application for French window sash

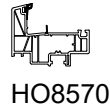

HO8570

VS8620-74  
Thickness  
2.0 mm  
 $I_x = 1.11 \text{ cm}^4$   
 $I_y = 2.48 \text{ cm}^4$

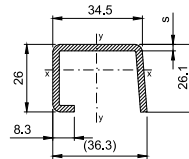

Application for sashes



HO8520

VS8055-75  
Thickness  
2.5 mm  
 $I_x = 1.65 \text{ cm}^4$   
 $I_y = 4.09 \text{ cm}^4$

Window type 1.2 Turn-only / bottom-hung window/door

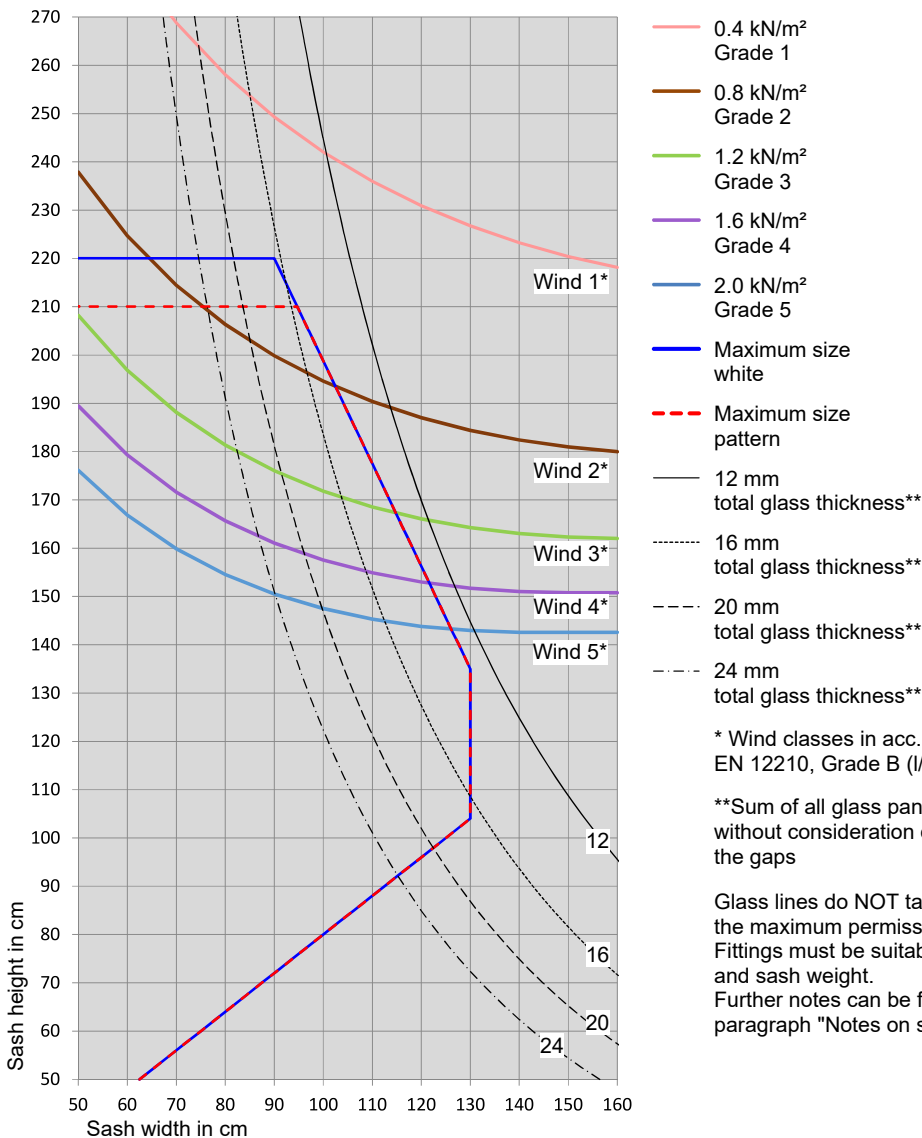
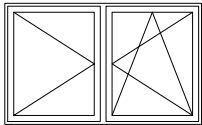

- 0.4 kN/m<sup>2</sup> Grade 1
- 0.8 kN/m<sup>2</sup> Grade 2
- 1.2 kN/m<sup>2</sup> Grade 3
- 1.6 kN/m<sup>2</sup> Grade 4
- 2.0 kN/m<sup>2</sup> Grade 5
- Maximum size white
- - - Maximum size pattern
- 12 mm total glass thickness\*\*
- ..... 16 mm total glass thickness\*\*
- - - 20 mm total glass thickness\*\*
- . - . 24 mm total glass thickness\*\*

\* Wind classes in acc. with EN 12210, Grade B (I/200)

\*\*Sum of all glass panes without consideration of the gaps

Glass lines do NOT take into account the maximum permissible sash weight. Fittings must be suitable for sash size and sash weight. Further notes can be found in paragraph "Notes on sash sizes".

French window sash

**VS8620-74**

Size diagram for strengthening VS8620, 2.0 mm - French window sash

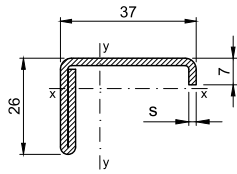

Application for French window sash



VS8620-74  
Thickness  
2.0 mm  
 $l_x = 1.11 \text{ cm}^4$   
 $l_y = 2.48 \text{ cm}^4$

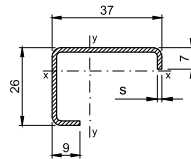

Application for sashes



VS8520-73  
Thickness  
1.5 mm  
 $l_x = 0.89 \text{ cm}^4$   
 $l_y = 1.72 \text{ cm}^4$

Window type 1.2 Turn-only / bottom-hung window/door

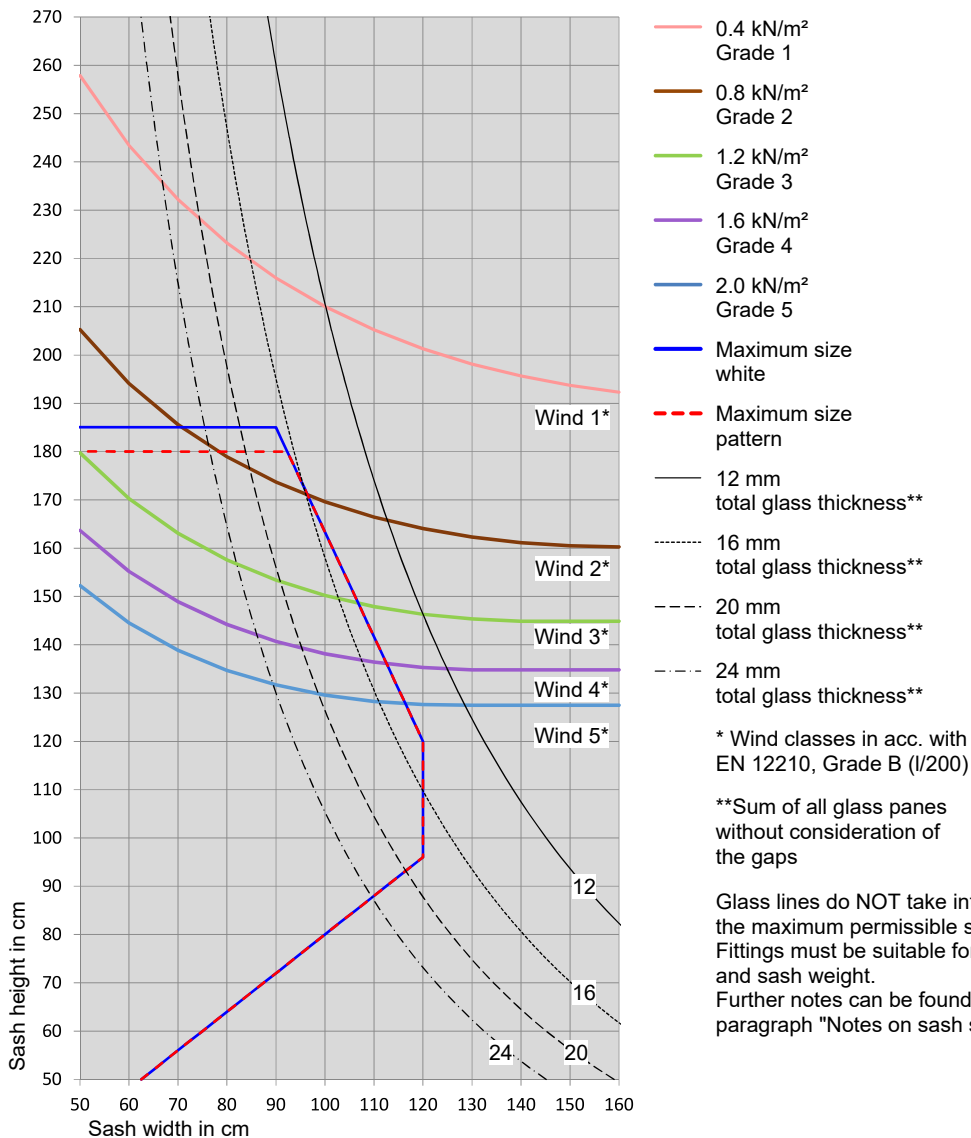
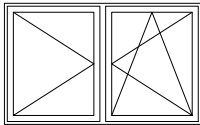

French window sash

VS8620-74

Size diagram for strengthening VS8620, 2.0 mm - French window sash

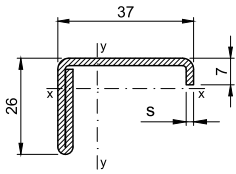

Application for French window sash

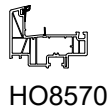

HO8570

VS8620-74  
Thickness  
2.0 mm  
 $I_x = 1.11 \text{ cm}^4$   
 $I_y = 2.48 \text{ cm}^4$

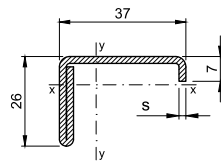

Application for sashes



HO8520

VS8620-74  
Thickness  
2.0 mm  
 $I_x = 1.11 \text{ cm}^4$   
 $I_y = 2.48 \text{ cm}^4$

Window type 1.2 Turn-only / bottom-hung window/door

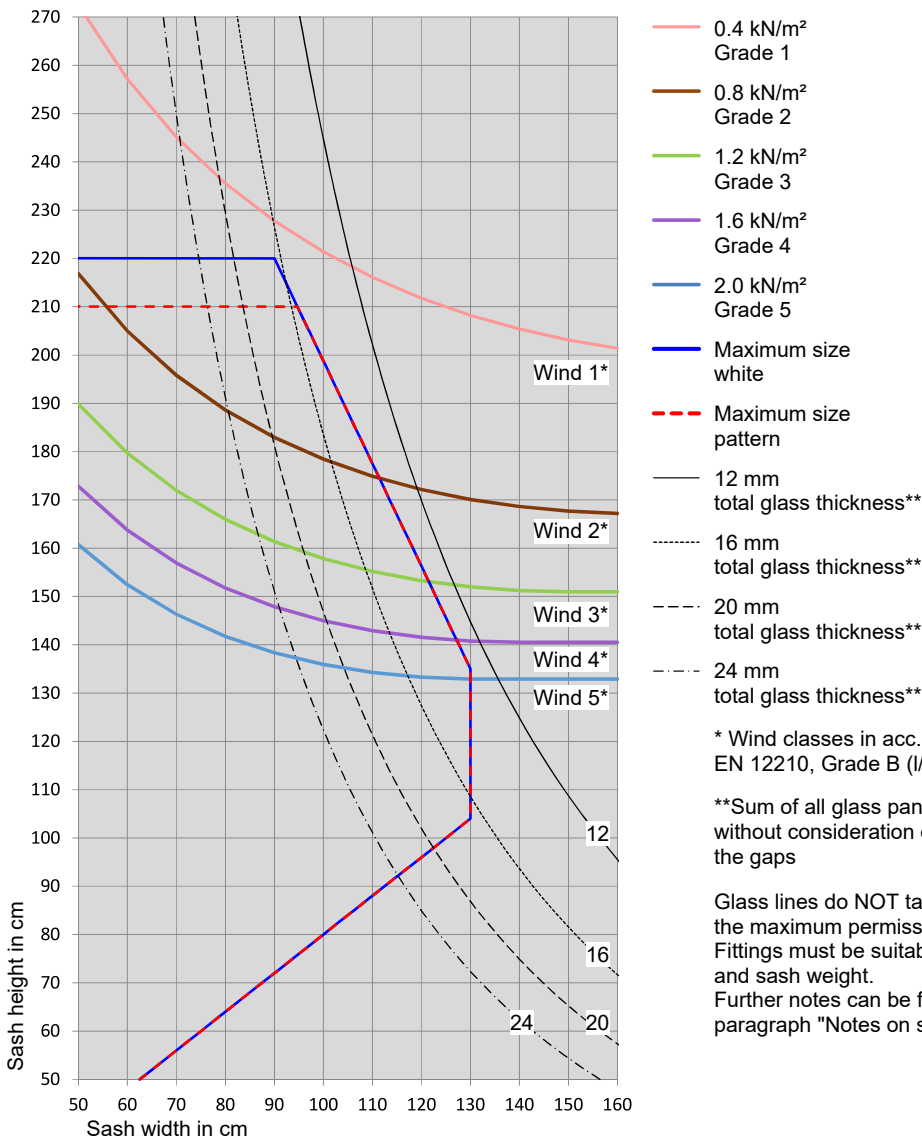
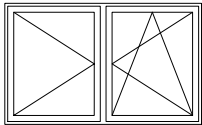

French window sash

**VS8620-74**

Size diagram for strengthening VS8620, 2.0 mm - French window sash

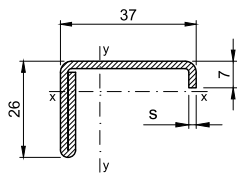

Application for French window sash

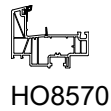

VS8620-74  
Thickness  
2.0 mm  
 $l_x = 1.11 \text{ cm}^4$   
 $l_y = 2.48 \text{ cm}^4$

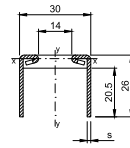

Application for sashes



VS9029  
Thickness  
1.5 mm  
 $l_x = 0.74 \text{ cm}^4$   
 $l_y = 1.90 \text{ cm}^4$

Window type 1.2 Turn-only / bottom-hung window/door

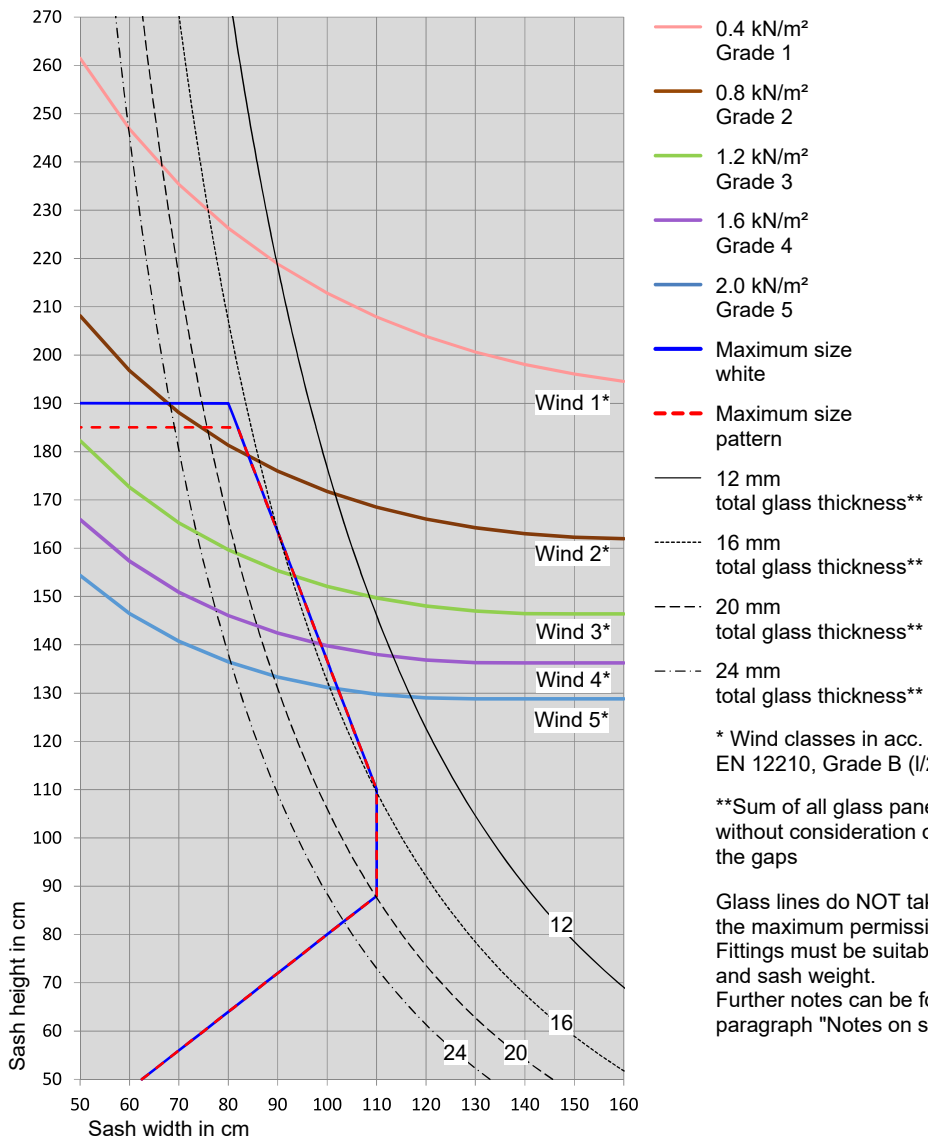
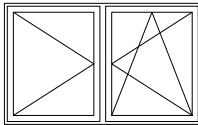

## Wind load

**Explanation wind load**

Wind acts on the structure through wind pressure. It is measured as wind loads. These wind loads are made up of wind pressure or wind suction and the corresponding surcharge values. The wind loads depend, among other things, on the height of the building, the position of the building and the shape of the building.

Wind loads can be applied according to the simplified procedure for wind loads in accordance with DIN EN 1991-1. They apply to installation heights of up to 25 m.

**Classification**

The classification of resistance to wind is carried out according to DIN EN 12210.

The aim is to guarantee:

- permanently tight glass edge seal of multi-pane insulating glazings
- sufficient tightness of window elements
- functional efficiency of window elements.

This is achieved by limiting the deformation of insulating glass panes ( $L/200$ , maximum 15 mm).

Class	P1 (in Pa)	P2 * (in Pa)	P3 (in Pa)
0	Not tested		
1	400	200	600
2	800	400	1200
3	1200	600	1800
4	1600	800	2400
5	2000	1000	3000
E xxxx **	xxxx		

\* This pressure must be repeated 50 times.

\*\* Test specimens with stress due to wind tested above class 5, are classified as E xxxx, if xxxx is the actual test pressure P1 (e.g. 2350, etc.).

**Wind speed**

Class	Pa	km/h	Wind strength	Designation
2A	50	33	5	Fresh breeze
3A	100	46	6	Strong wind
4A	150	56.5	7	Stiff wind
5A	200	65	8	Stormy wind
6A	250	72	8	Stormy wind
7A	300	79	9	Storm
8A	450	98	10	Severe storm
9A	600	113	11	Hurricane-like storm
E750	750	127	12	Hurricane

Wind zones

**Wind zones**

Germany is divided into 4 wind zones. Depending on the location, different wind loads result. The wind load is indicated with the value for V/REF. V/REF indicates the time-averaged wind speed in m/s with the corresponding speed pressure q/REF in kN/m<sup>2</sup>.

**Wind zone map Germany**

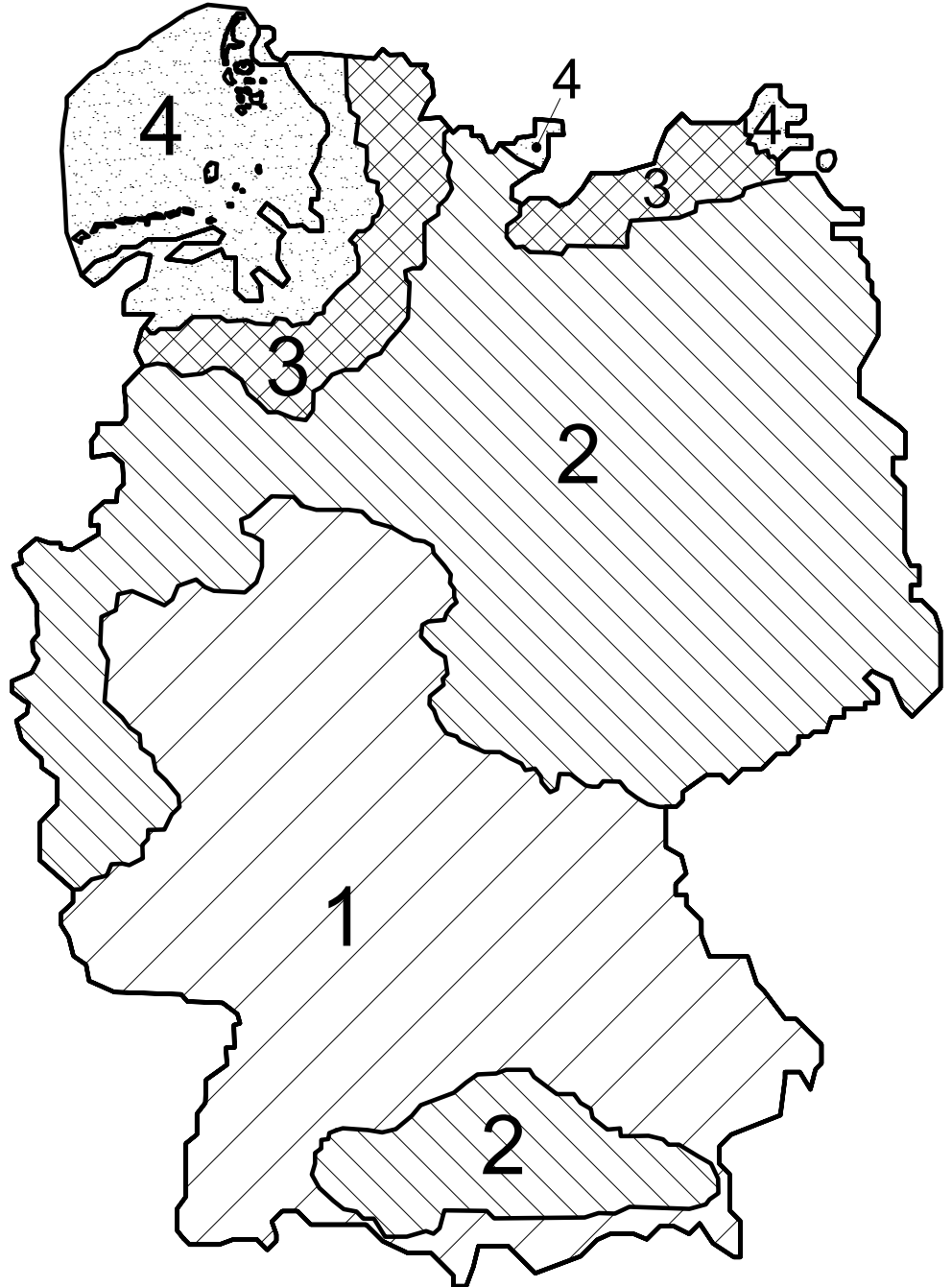

Wind zone	1	2	3	4
V/REF in m / s	22.5	25.0	27.5	30.0
q/REF in kN / m <sup>2</sup>	0.32	0.39	0.47	0.56
Marking				

Stress classes for windows

In accordance with DIN 18055.

Inland	Wind zone 1						Wind zone 2						Wind zone 3						Wind zone 4					
	0 – 10 m		>10 – 18 m		> 18 – 25 m		0 – 10 m		>10 – 18 m		> 18 – 25 m		0 – 10 m		>10 – 18 m		> 18 – 25 m		0 – 10 m		>10 – 18 m		> 18 – 25 m	
	Centre	Edge	Centre	Edge	Centre	Edge	Centre	Edge	Centre	Edge	Centre	Edge	Centre	Edge	Centre	Edge	Centre	Edge	Centre	Edge	Centre	Edge	Centre	Edge
Velocity pressure in kN/m <sup>2</sup> according to DIN EN 1991-1	0.50	0.50	0.65	0.65	0.75	0.75	0.65	0.65	0.80	0.80	0.90	0.90	0.80	0.80	0.95	0.95	1.10	1.10	0.95	0.95	1.15	1.15	1.30	1.30
Wind load - wind pressure in kN/m <sup>2</sup> cpe,1 = 1.0/1.0	0.50	0.50	0.65	0.65	0.75	0.75	0.65	0.65	0.80	0.80	0.90	0.90	0.80	0.80	0.95	0.95	1.10	1.10	0.95	0.95	1.15	1.15	1.30	1.30
Wind load - wind suction in kN/m <sup>2</sup> cpe,1 = 1.1/-1.7	0.55	0.85	0.72	1.11	0.83	1.28	0.72	1.11	0.88	1.36	0.99	1.53	0.88	1.36	1.05	1.62	1.21	1.87	1.05	1.62	1.27	1.96	1.43	2.21
Resistance to wind load according to DIN EN 14351-1	B2	B3	B2	B3	B3	B4	B2	B3	B3	B4	B3	B4	B3	B4	B3	B5	B4	B5	B3	B5	B4	B5	B4	E22 10
Water tightness according to DIN EN 14351-1	4A	4A	5A	5A	5A	5A	5A	5A	5A	5A	6A	6A	5A	5A	6A	6A	7A	7A	6A	6A	7A	7A	8A	8A
Air permeability according to DIN EN 14351-1	2	2	2 (3)	2 (3)	2 (3)	3	2	2	2 (3)	3	2 (3)	3	2	2	3	2	3	3	2	2	3	3	3	4
Coast and islands of the Baltic Sea	Wind zone 2						Wind zone 3						Wind zone 4											
Velocity pressure in kN/m <sup>2</sup> according to DIN EN 1991-1	0 – 10 m		>10 – 18 m		> 18 – 25 m		0 – 10 m		>10 – 18 m		> 18 – 25 m		0 – 10 m		>10 – 18 m		> 18 – 25 m		0 – 10 m		>10 – 18 m		> 18 – 25 m	
	Centre	Edge	Centre	Edge	Centre	Edge	Centre	Edge	Centre	Edge	Centre	Edge	Centre	Edge	Centre	Edge	Centre	Edge	Centre	Edge	Centre	Edge	Centre	Edge
Wind load - wind pressure in kN/m <sup>2</sup> cpe,1 = 1.0/1.0	0.85	0.85	1.00	1.00	1.10	1.10	1.05	1.05	1.20	1.20	1.30	1.30	1.05	1.05	1.20	1.20	1.30	1.30	1.25	1.25	1.40	1.40	1.55	1.55
Wind load - wind suction in kN/m <sup>2</sup> cpe,1 = 1.1/-1.7	0.94	1.45	1.10	1.70	1.21	1.87	1.16	1.79	1.32	2.04	1.43	2.21	1.38	2.12	1.54	2.38	1.71	2.63	1.38	2.12	1.54	2.38	1.71	2.63

Stress classes for windows

Inland	Wind zone 1						Wind zone 2						Wind zone 3						Wind zone 4							
	0 – 10 m		>10 – 18 m		> 18 – 25 m		0 – 10 m		>10 – 18 m		> 18 – 25 m		0 – 10 m		>10 – 18 m		> 18 – 25 m		0 – 10 m		>10 – 18 m		> 18 – 25 m			
	Centre	Edge	Centre	Edge	Centre	Edge	Centre	Edge	Centre	Edge	Centre	Edge	Centre	Edge	Centre	Edge	Centre	Edge	Centre	Edge	Centre	Edge	Centre	Edge		
Resistance to wind load according to DIN EN 14351-1	B3	B4	B3	B5	B4	B5	B3	B5	B4	B5	B3	B5	B4	E20 40	B4	E22 10	B4	E21 25	B4	B4	B4	E23 80	B5	E26 35		
Water tightness according to DIN EN 14351-1	6A	6A	6A	6A	6A	6A	6A	6A	6A	6A	6A	6A	6A	7A	7A	7A	7A	7A	7A	7A	7A	7A	7A	7A		
Air permeability according to DIN EN 14351-1	2	3	2 (3)	3	3	3	2	3	3	3	2	3	3	4	3	4	3	4	3	3	4	3	3	4		
Coast of the North Sea	Wind zone 4																									
Velocity pressure in kN/m <sup>2</sup> according to DIN EN 1991-1	1.25		1.25		1.25		1.25		1.25		1.25		1.25		1.25		1.25		1.25		1.25		1.25		1.25	
Wind load - wind pressure in kN/m <sup>2</sup> cpe,1 = 1.0/1.0	1.25		1.25		1.25		1.25		1.25		1.25		1.25		1.25		1.25		1.25		1.25		1.25		1.25	
Wind load - wind suction in kN/m <sup>2</sup> cpe,1 = 1.1/-1.7	1.38		2.12 5		1.54		2.38		1.71		2.63 5		1.40		1.55		2.38		1.71		2.63 5		1.40		1.55	
Resistance to wind load according to DIN EN 14351-1	B4	E21 25	B4	B4	B4	B5	B3	B5	B4	B5	B3	B5	B4	E20 40	B4	E22 10	B4	E21 25	B4	B4	B4	E23 80	B5	E26 35		
Water tightness according to DIN EN 14351-1	8A	8A	8A	8A	8A	8A	8A	8A	8A	8A	8A	8A	8A	7A	7A	7A	7A	7A	7A	7A	7A	7A	7A	7A		
Air permeability according to DIN EN 14351-1	3	4	3	4	3	4	3	4	3	4	3	4	3	4	3	4	3	4	3	3	4	3	3	4		

Stress classes for windows

Inland	Wind zone 1			Wind zone 2			Wind zone 3			Wind zone 4		
	0 – 10 m	>10 – 18 m	> 18 – 25 m	0 – 10 m	>10 – 18 m	> 18 – 25 m	0 – 10 m	>10 – 18 m	> 18 – 25 m	0 – 10 m	>10 – 18 m	> 18 – 25 m
	Centre Edge	Centre Edge	Centre Edge	Centre Edge	Centre Edge	Centre Edge	Centre Edge	Centre Edge	Centre Edge	Centre Edge	Centre Edge	Centre Edge
Islands of the North Sea	Wind zone 4											
Velocity pressure in kN/m <sup>2</sup> according to DIN EN 1991-1	Special calculation required											
Wind load - wind pressure in kN/m <sup>2</sup> cpe,1 = 1.0/1.0	1.40 1.40											
Wind load - wind suction in kN/m <sup>2</sup> cpe,1 = 1.1/-1.7	1.54 2.38											
Resistance to wind load according to DIN EN 14351-1	B4 E23 80											
Water tightness according to DIN EN 14351-1	8A 8A											
Air permeability according to DIN EN 14351-1	3 4											
NOTE 1 For air permeability, a class is given in brackets if the requirement according to DIN 4108-2 results in a higher class than the calculation (see 4.12).												
NOTE 2 The pair of values given for cpe,1 refers in each case to the centre of the building or the edge of the building.												

Stress classes for exterior doors with thermal insulation requirements

In accordance with DIN 18055.

Building height (m)	Location	Wind load	Driving rain tightness*	Air permeability
0 to 8	Protected installation	B 2	NPD to 4 B	2
	Non-protected installation	B 2	4 A	2

\* In certain structural situations, air permeability class 3 may also be necessary for exterior doors.

**Explanation of driving rain tightness**

Driving rain tightness is the resistance of a window to water penetration into the interior of the building or into areas that cannot be drained to the outside in a controlled manner. The window is closed and locked at a defined wind force, amount of rain and duration of exposure.

The building location, the installation height and the installation situation of the window element are decisive for the classification according to the product standard for windows and doors (DIN EN 14351-1).

**Classification**

Classification DIN EN 12208		Test method DIN EN 1027 ( $\Delta p$ in Pa)
1 A	1 B	0
2 A	2 B	50
3 A	3 B	100
4 A	4 B	150
5 A	5 B	200
6 A	6 B	250
7 A	7 B	300
8 A	-	450
9 A	-	600
E xxx	-	> 600
1 A to 9 A = Suitability for unprotected installation position of windows 1 B to 7 B = Suitability for protected installation position of windows 0 Pa 15 min. Pressurisation in steps of 5 min. each		

## Imprint

**Publisher:**

Salamander Industrie-Produkte GmbH  
Jakob-Sigle-Straße 58  
86842 Türkheim/Unterallgäu  
Germany

Telephone: +49 8245 52 0  
Fax: +49 8245 52 359  
info@salamander-windows.com  
salamander-windows.com

**Company management:**

Götz Schmiedeknecht  
Till Schmiedeknecht  
Wolfgang Sandhaus

**Legal form:**

Private limited company

**Headquarters:**

Türkheim/Unterallgäu

**Register court:**

District Court Memmingen

**Register number:**

HRB 5175

**VAT ID No.:**

DE129089528

© 2025,  
SALAMANDER Industrie-Produkte GmbH,  
86842 Türkheim  
All rights reserved.

Changes, errors, printing and typesetting errors reserved.

Salamander Industrie-Produkte GmbH

Jakob-Sigle-Straße 58  
86842 Türkheim/Unterallgäu  
Deutschland

