

G100T

ISICAMLI GIYOTIN SÜRME CAM BALKON SİSTEMİ
VERTICAL SLIDING GLASS BALCONY SYSTEM WITH THERMAL GLASS

ASISTAL

KESİM ve MONTAJ
CUTTING & ASSEMBLY

G100T

ISICAMLI GIYOTIN SÜRME CAM BALKON SİSTEMİ
VERTICAL SLIDING GLASS BALCONY SYSTEM WITH THERMAL GLASS



G100T A1

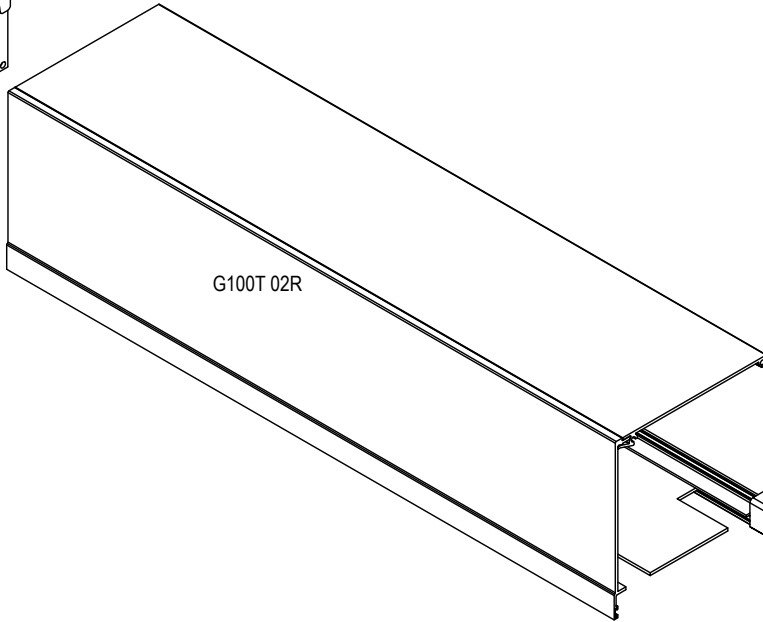
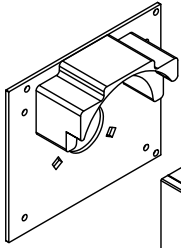

G100T 02R

G100T A1

G100T 02R

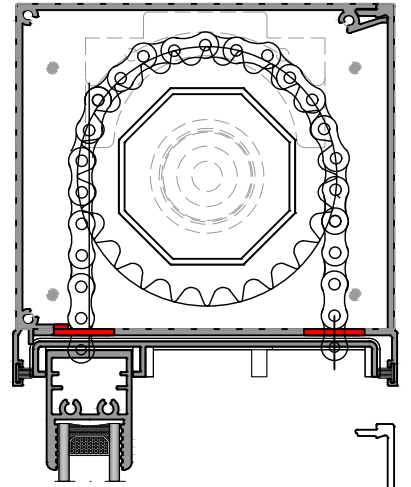

G100T 02B

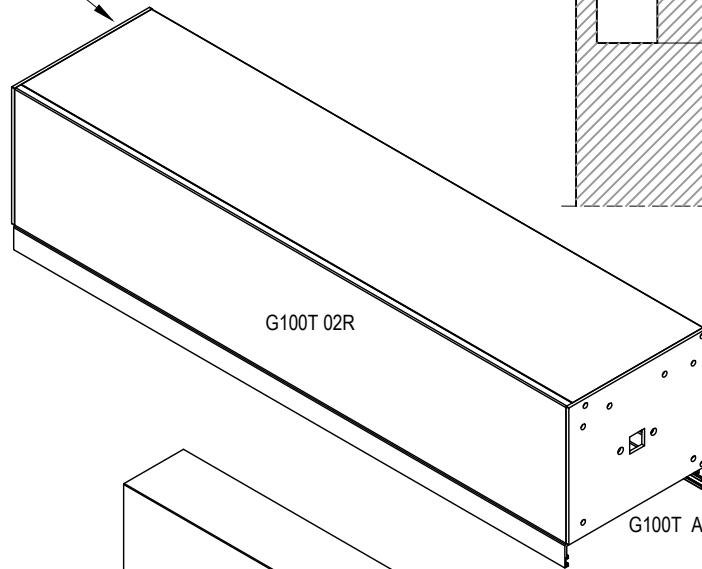
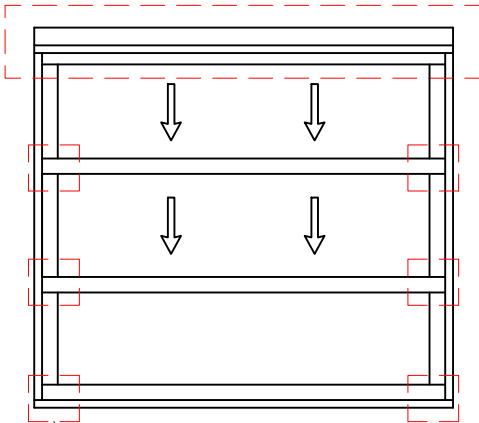
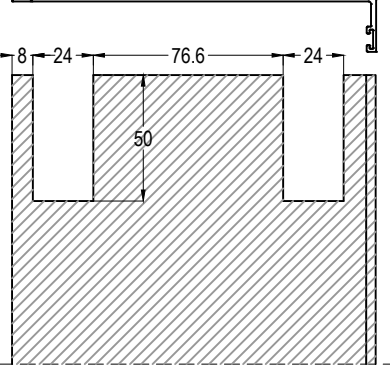

G100T 02R

G100T A1

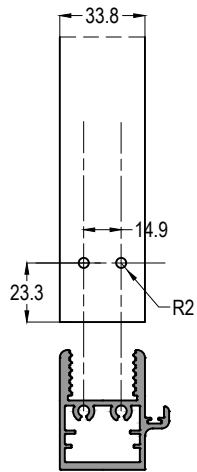

G100T 12

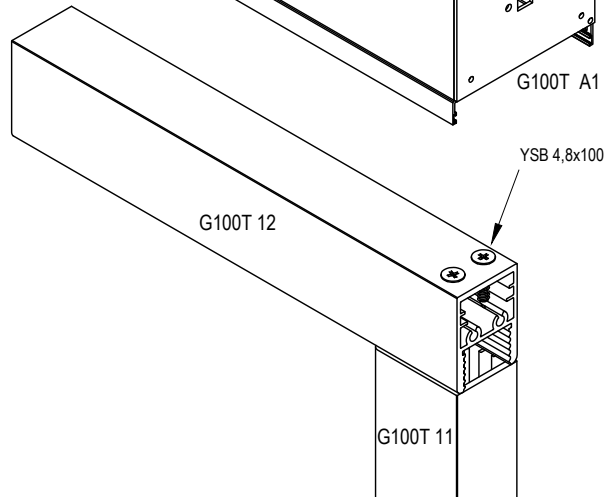

G100T 12

YSB 4,8x100

G100T 11

G100T

ISICAMLI GIYOTIN SÜRME CAM BALKON SİSTEMİ
VERTICAL SLIDING GLASS BALCONY SYSTEM WITH THERMAL GLASS

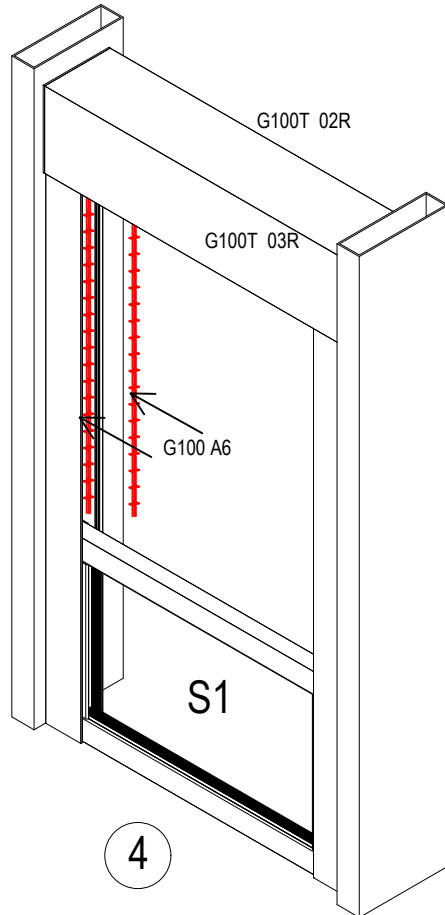
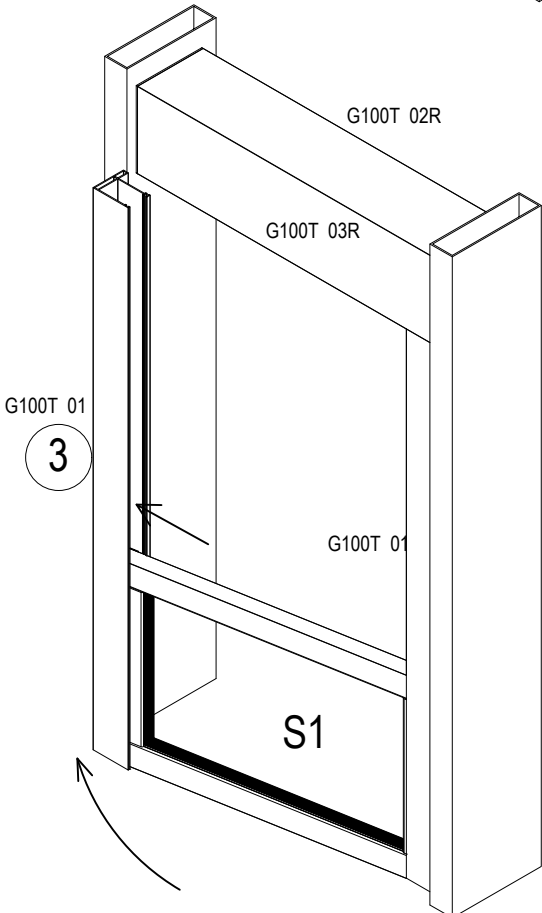
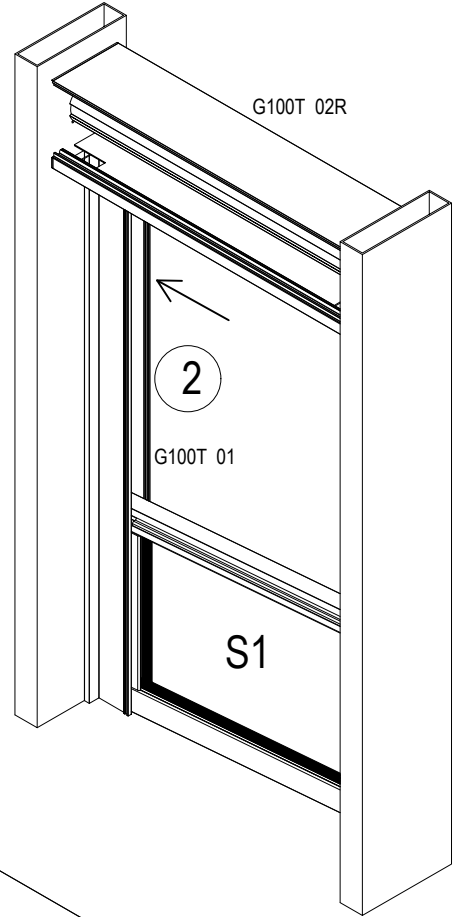
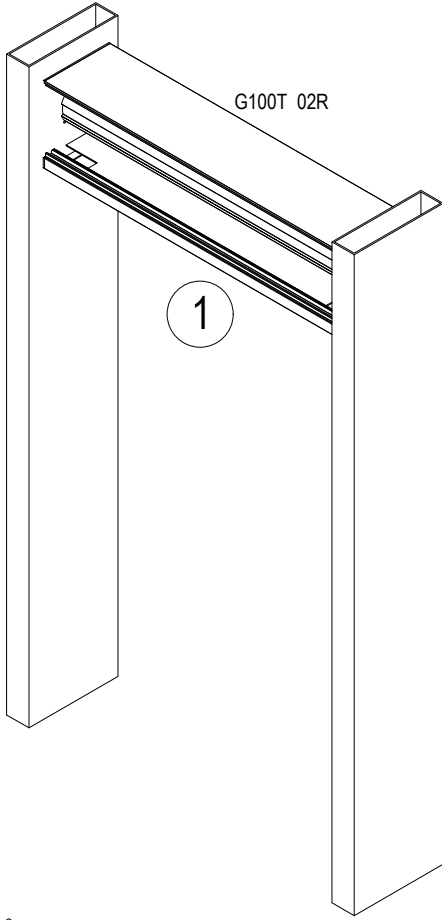

G100T

ISICAMLI GIYOTİN SÜRME CAM BALKON SİSTEMİ
VERTICAL SLIDING GLASS BALCONY SYSTEM WITH THERMAL GLASS

ASISTAL

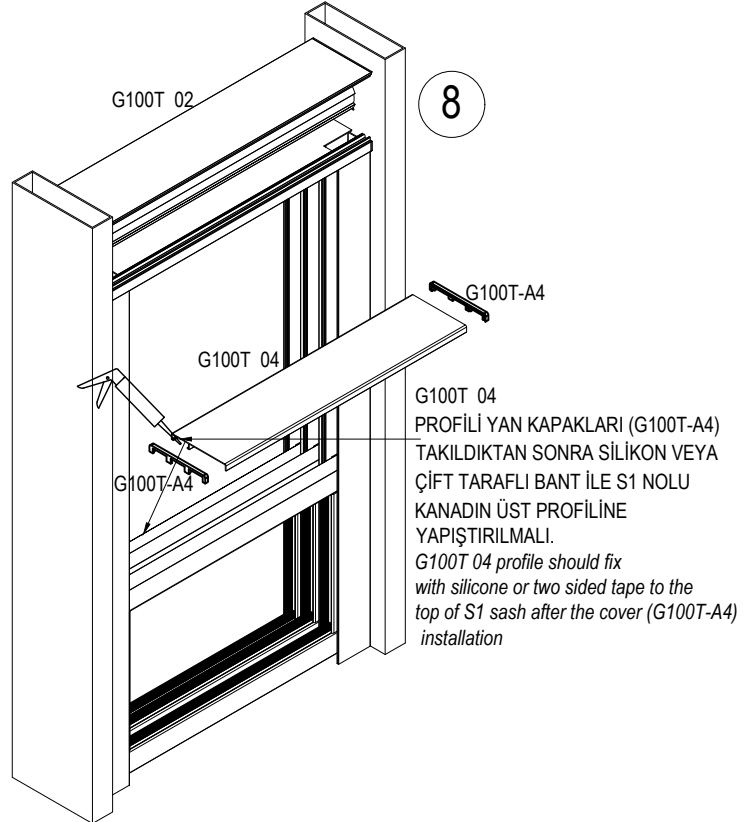
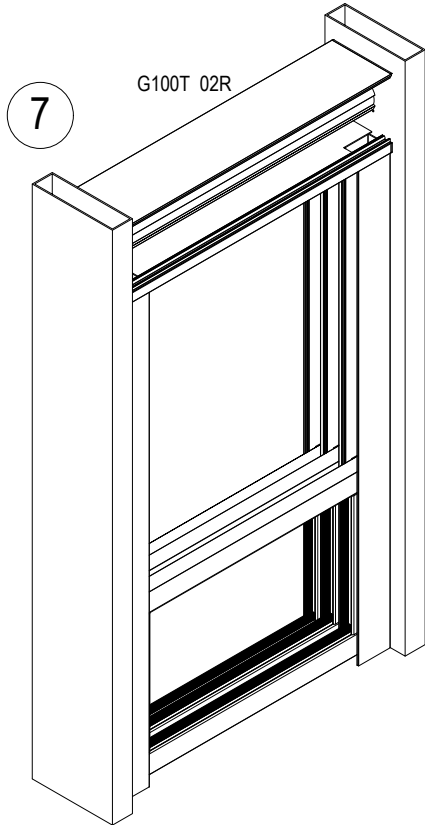
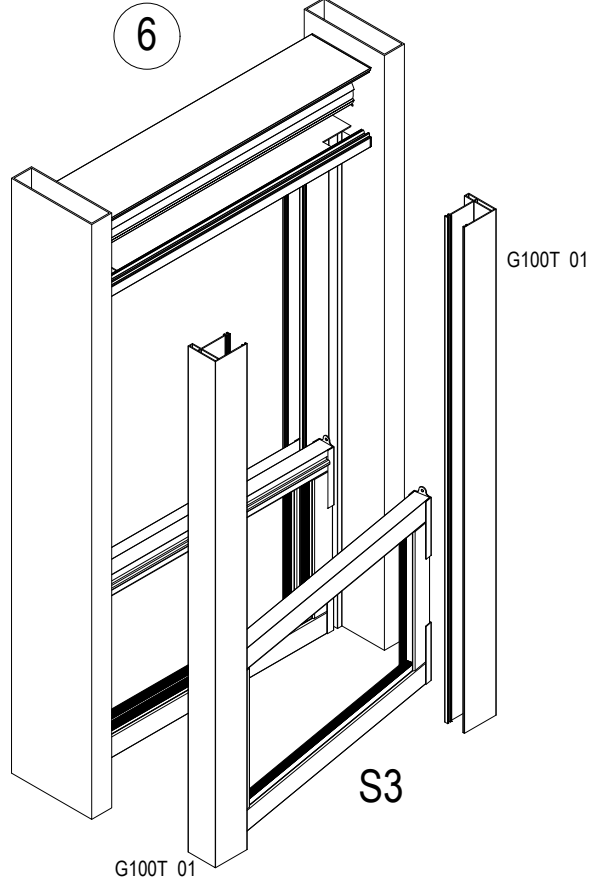
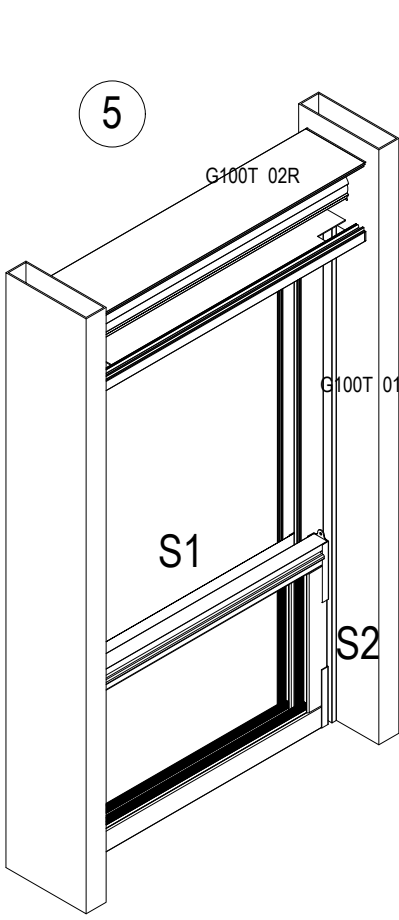

G100T

ISICAMLI GIYOTIN SÜRME CAM BALKON SİSTEMİ
VERTICAL SLIDING GLASS BALCONY SYSTEM WITH THERMAL GLASS



9

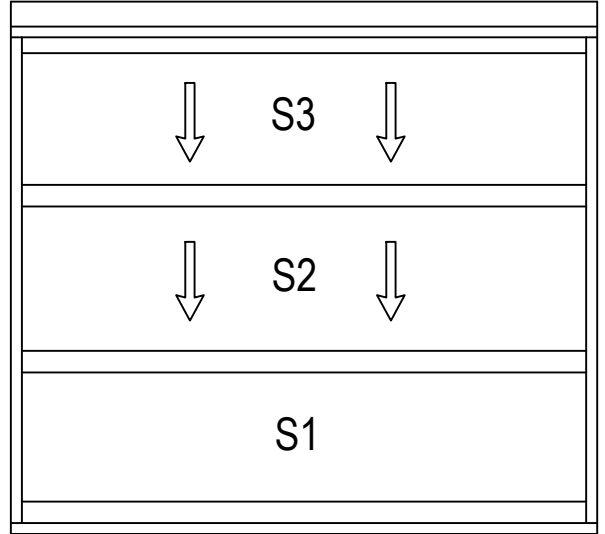
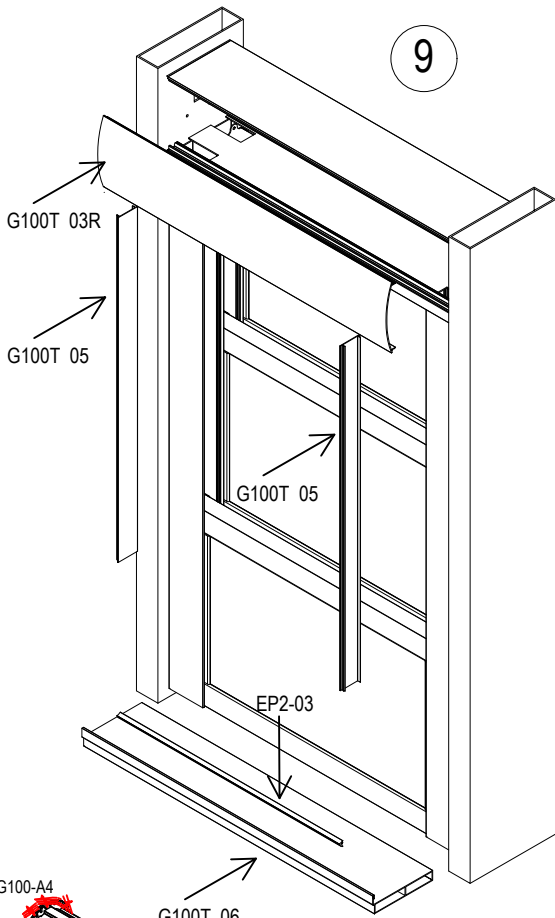

10

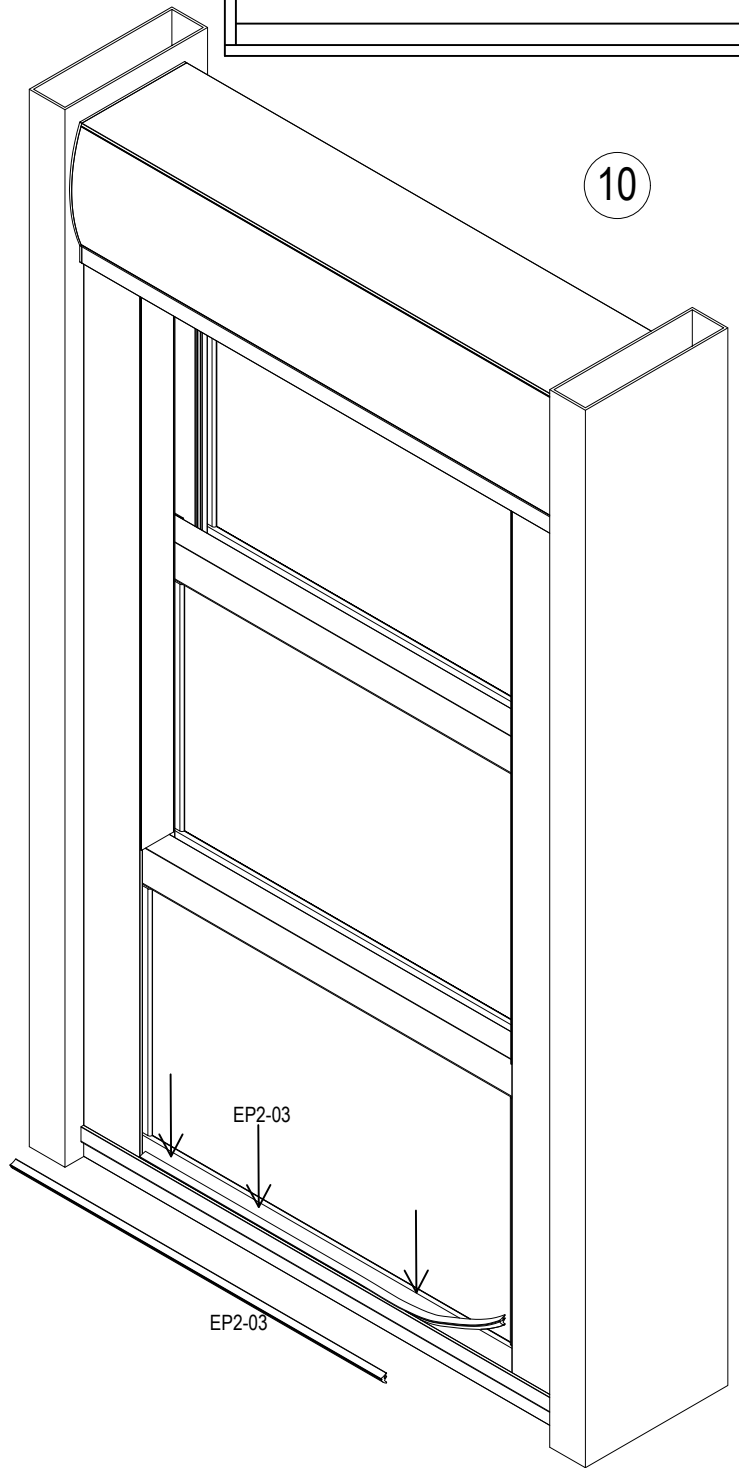
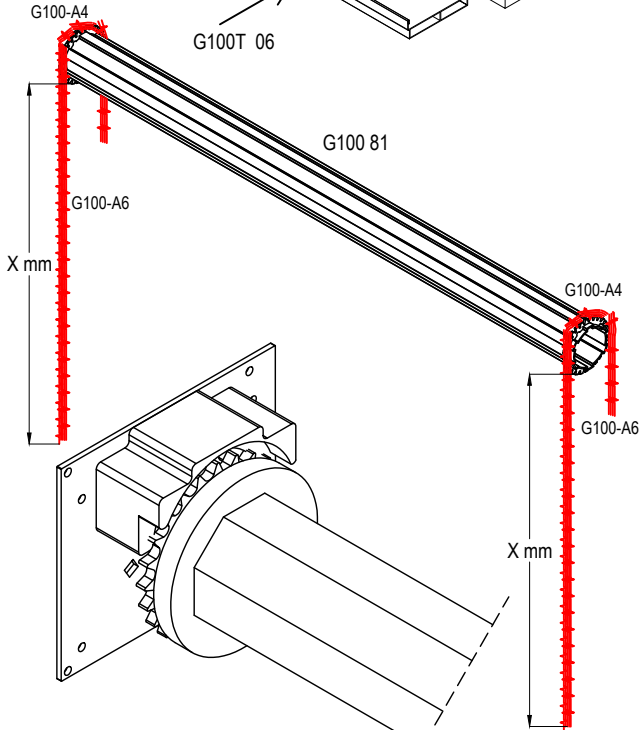

G100T-A1
G100-A11

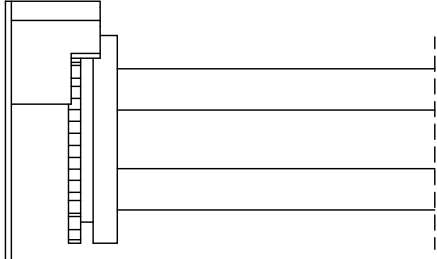

G100T

ISICAMLI GIYOTIN SÜRME CAM BALKON SİSTEMİ
VERTICAL SLIDING GLASS BALCONY SYSTEM WITH THERMAL GLASS

ASISTAL

TEKCAM UYGULAMASI SINGLE GLAZING ASSEMBLY

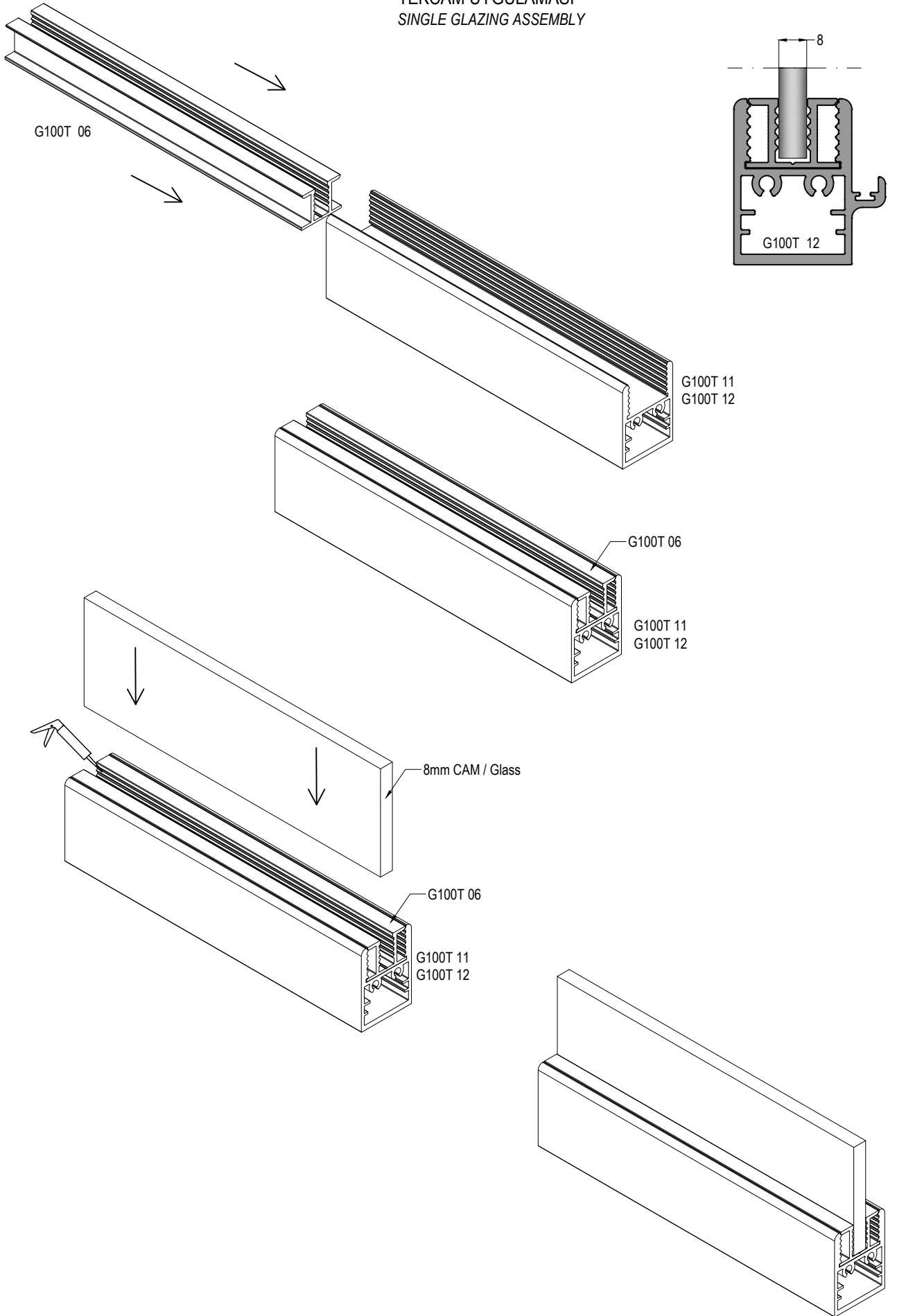

G100T

ISICAMLI GIYOTIN SURME CAM BALKON SISTEMI
VERTICAL SLIDING GLASS BALCONY SYSTEM WITH THERMAL GLASS

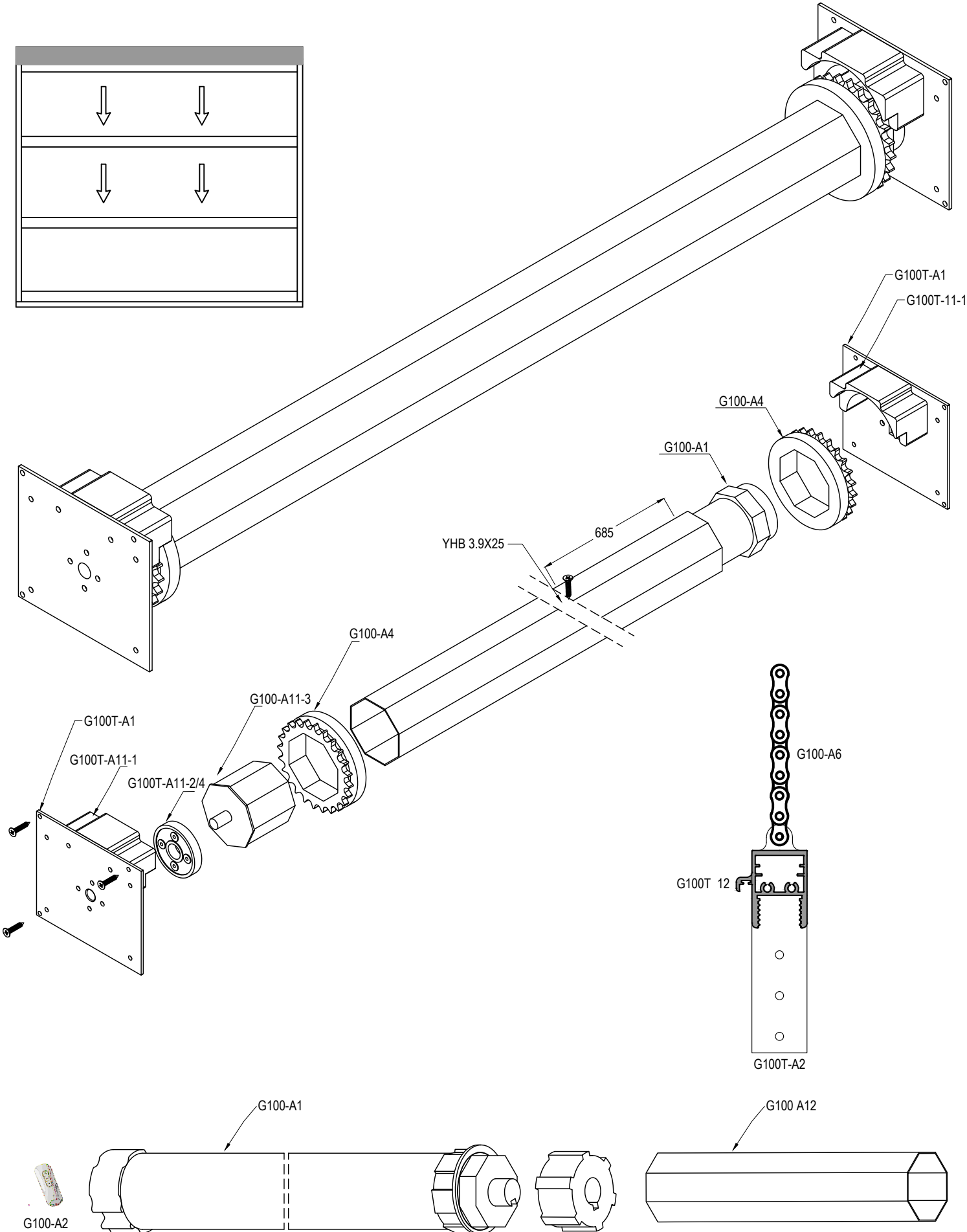
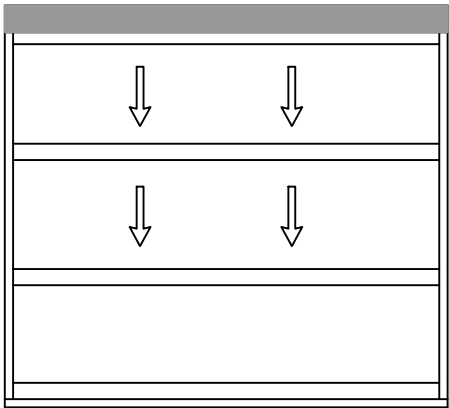

G100-A2

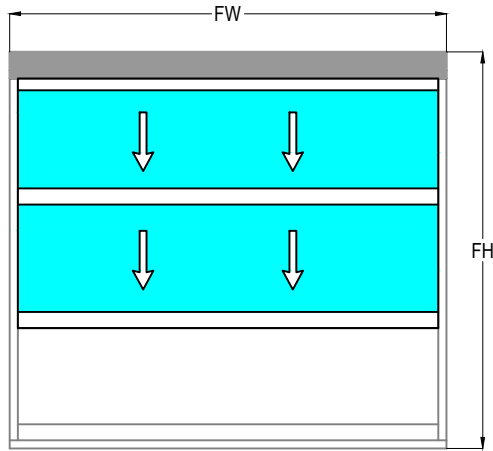

NOT: MAX KASA ENİ 4500mm, MAX KASA YÜKSEKLİĞİ 3000mm
MAX FRAME WITDH 4500mm, MAX FRAME HEIGHT 3000mm

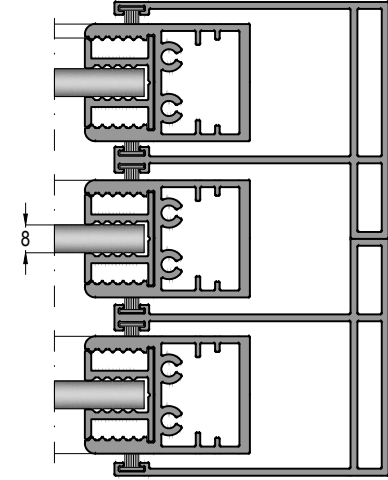

G100T 2 KANAT AĞIRLIKLARI (8mm Cam) - 2 SASH WEIGHTS (8mm Glass)

GENİŞLİK (MM) FW - WIDTH

YÜKSEKLİK (MM) FH - HEIGHT	KG.	1000	1250	1500	1750	2000	2250	2500	2750	3000	3250	3500	3750	4000	4250	4500
	1400	28,58	34,97	41,36	47,75	54,14	60,53	66,93	73,32	79,71	86,10	92,49	98,88	105,27	111,66	118,05
1500	30,13	36,85	43,58	50,30	57,03	63,75	70,47	77,20	83,92	90,65	97,37	104,09	110,82	117,54	124,27	
1600	31,68	38,74	45,79	52,85	59,87	66,97	74,02	81,80	88,14	95,19	102,25	109,31	116,37	123,42	130,48	
1700	33,23	40,62	48,01	55,40	62,71	70,18	77,57	84,96	92,35	99,74	107,13	114,53	121,92	129,31	136,70	
1800	34,78	42,50	50,22	57,95	65,67	73,40	81,12	88,84	96,57	104,29	112,02	119,74	127,46	135,19	142,91	
1900	36,33	44,38	52,44	60,50	68,51	76,61	84,67	92,73	100,78	108,84	116,90	124,96	133,01	141,07	149,13	
2000	37,87	46,27	54,66	63,05	71,44	79,83	88,22	96,61	105,00	113,39	121,78	130,17	138,56	146,95	155,34	
2100	39,42	48,15	56,87	65,60	74,32	83,04	91,77	100,49	109,22	117,94	126,66	135,39	144,11	152,84	161,56	
2200	40,97	50,03	59,09	68,14	77,20	86,26	95,32	104,37	113,43	122,49	131,55	140,60	149,66	158,72	167,73	
2300	42,52	51,91	61,30	70,69	80,08	89,47	98,87	108,26	117,65	127,04	136,43	145,82	155,21	164,60	173,99	
2400	44,07	53,79	63,52	73,24	82,97	92,69	102,41	112,14	121,86	131,59	141,31	151,03	160,76	170,48	180,21	
2500	45,62	55,68	65,73	75,79	85,85	95,91	105,96	116,02	126,08	136,14	146,19	156,25	166,31	176,36	186,42	
2600	47,17	57,56	67,95	78,34	88,73	99,12	109,51	119,90	130,29	140,68	151,07	161,47	171,86	182,25	192,64	
2700	48,72	59,44	70,17	80,89	91,61	102,24	113,06	123,79	134,51	145,23	155,96	166,68	177,41	188,13	198,85	
2800	50,27	61,32	72,38	83,44	94,50	105,55	116,61	127,67	138,72	149,78	160,84	171,90	182,95	194,01	205,07	
2900	51,82	63,21	74,60	85,99	97,38	108,77	120,16	131,55	142,94	154,33	165,72	177,11	188,50	199,89	211,28	
3000	53,36	65,09	76,81	88,54	100,26	111,98	123,71	135,43	147,16	158,88	170,60	182,33	194,05	205,78	217,50	

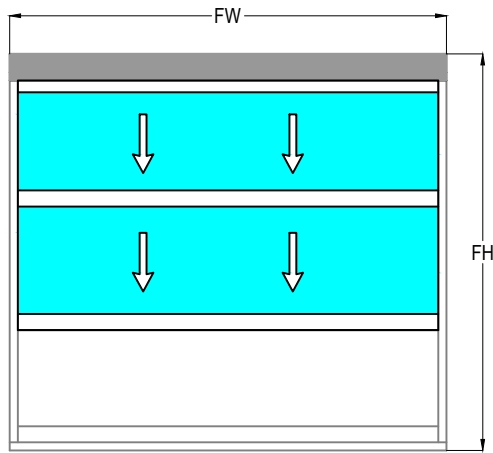

NOT: MAX KASA ENİ 4500mm, MAX KASA YÜKSEKLİĞİ 3000mm
MAX FRAME WITDH 4500mm, MAX FRAME HEIGHT 3000mm

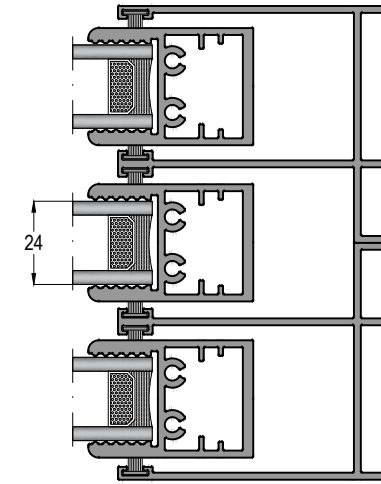

G100T 2 KANAT AĞIRLIKLARI (4+16+4mm Cam) - 2 SASH WEIGHTS (4+16+4mm Glass)

GENİŞLİK (MM) FW - WIDTH

YÜKSEKLİK (MM) FH - HEIGHT	KG.	1000	1250	1500	1750	2000	2250	2500	2750	3000	3250	3500	3750	4000	4250	4500
	1400	26,77	32,86	38,94	45,02	51,10	57,19	63,27	69,35	75,44	81,52	87,60	93,68	99,77	105,85	111,93
1500	28,28	34,70	41,11	47,53	53,95	60,36	66,78	73,19	79,61	86,03	92,44	98,86	105,27	111,69	118,11	
1600	29,79	36,54	43,29	50,04	56,79	63,54	70,29	77,04	83,78	90,53	97,28	104,03	110,78	117,53	124,28	
1700	31,30	38,38	45,46	52,55	59,63	66,71	73,79	80,88	87,96	95,04	102,12	109,21	116,29	123,37	130,46	
1800	32,81	40,22	47,64	55,05	62,47	69,89	77,30	84,72	92,13	99,55	106,97	114,38	121,80	129,21	136,63	
1900	34,31	42,06	49,81	57,56	65,31	73,06	80,81	88,56	96,31	104,06	111,81	119,56	127,31	135,05	142,80	
2000	35,82	43,90	51,99	60,07	68,15	76,23	84,32	92,40	100,48	108,57	116,65	124,73	132,81	140,90	148,98	
2100	37,33	45,75	54,16	62,58	70,99	79,81	87,83	96,24	104,66	113,07	121,49	129,91	138,32	146,74	155,15	
2200	38,84	47,59	56,34	65,09	73,83	82,58	91,33	100,08	108,83	117,58	126,33	135,05	143,83	152,58	161,33	
2300	40,34	49,43	58,51	67,59	76,68	85,56	94,84	103,92	113,01	122,09	131,17	140,25	149,34	158,42	167,50	
2400	41,85	51,27	60,68	70,10	79,52	88,93	98,35	107,76	117,18	126,60	136,01	145,43	154,84	164,26	173,68	
2500	43,36	53,11	62,86	72,61	82,36	92,11	101,86	111,61	121,3	131,10	140,85	150,60	160,35	170,10	179,85	
2600	44,87	54,95	65,03	75,12	85,20	95,28	105,36	115,45	125,53	135,61	145,70	155,78	165,86	175,94	186,03	
2700	46,38	56,79	67,21	77,62	88,04	98,46	108,87	119,29	129,70	140,12	150,54	160,95	171,37	181,78	192,20	
2800	47,88	58,63	69,38	80,13	90,88	101,63	112,38	123,13	133,88	144,63	155,38	166,13	176,88	187,63	198,37	
2900	49,39	60,47	71,56	82,64	93,72	104,81	115,89	126,97	138,05	149,14	160,22	171,30	182,38	193,47	204,55	
3000	50,90	62,32	73,73	85,15	96,56	107,98	119,40	130,81	142,23	153,64	165,06	176,48	187,89	199,31	210,72	

MOTOR LİMİTLEME MOTOR LIMITING

G100-A1



G100-A2



70'LİK SERİ GIYOTİN MOTORU

WHITEPLUS ALICILI MOTORUN OKUTULMASI-SİLİNMESİ OKUTULMASI:

- ÖNCELİKLİ OLARAK MONTAJI YAPILMIŞ MOTORA ELEKTRİĞİ VERİYORUZ.
- KUMANDAYI MOTORA KODLAMAK İÇİN:
- KUMANDANIN ÜST VE ALT TUŞUNA AYNI ANDA BASILI TUTUYORUZ.
- MOTOR YUKARI-AŞAĞI UFAK HAREKETLERLE BİLDİRİM VERECEKTİR.
- DAHA SONRA MOTORUN YÖNÜ KONTROL EDİLİR.
- BU İŞLEM İÇİN KUMANDANIN ALT TUŞUNA BİR KERE BASILIR.
- GIYOTİN AŞAĞI İNİYOR İSE İŞLEM DOĞRUDUR.
- KUMANDANIN YUKARI VE AŞAĞI TUŞUNA AYNI ANDA BASILIR.
- MOTORDAN YUKARI VE AŞAĞI GERİ BİLDİRİM GELDİĞİ TAKTİRDE MOTORUN YÖNÜ HAFIZAYA ALDIĞI ANLAŞILIR.

YÖN TERS İSE:

- KUMANDANIN ORTA TUŞUNA BASILI TUTULUR.
- MOTOR YUKARI-AŞAĞI BİLDİRİM VERİR.
- MOTORUN YÖNÜ DEĞİŞİR.
- DAHA SONRA ALT VE ÜST SWİÇ AYARLARINA GEÇİLİR.
- ÖNCE ALT SWİÇTEN BAŞLANIR.
- ALT SWİÇ İÇİN KUMANDANIN ALT TUŞUNA BASILI TUTULUR.
- GIYOTİN İSTENEN ALT SEVİYEYE İNDİRİLİR.
- KUMANDANIN ORTA TUŞUNA BASILI TUTULURAK ALT LİMİT HAFIZAYA ALINIR.
- BU ESNADA MOTOR YUKARI AŞAĞI GERİ BİLDİRİM VERİR.
- ÜST SWİÇ İÇİN KUMANDANIN ÜST TUŞUNA BASILI TUTULUR.
- KEPENK İSTENİLEN ÜST SEVİYEYE ÇIKARILIR.
- KUMANDANIN ORTA TUŞUNA BASILI TUTULURAK ÜST LİMİT HAFIZAYA ALINIR.
- BU ESNADA MOTOR YUKARI AŞAĞI İKİ DEFA GERİ BİLDİRİM VERİR.
- PANJURSUZ KULLANIMA HAZIRDIR.

SİLME İŞLEMİ:

- ELEKTRİK KESİLİR 10 SN BEKLENİR.
- SONRA ELEKTRİK TEKRAR VERİLİR.
- KUMANDANIN ÜST-ALT VE ORTA TUŞUNA AYNI ANDA BASILI TUTULUR.
- MOTOR YUKARI-AŞAĞI GERİ BİLDİRİM VERİR.
- SONRA KUMANDANIN ARKASINDAKİ PROGRAM TUŞUNA BASILI TUTULUR.
- MOTOR BİRİNCİ YUKARI AŞAĞI BİLDİRİM VERİR.
- DÜĞMEYE BASMAYA DEVAM EDEREK BEKLENMELİDİR.
- YAKLAŞIK 7 SN SONUNDA İKİNCİ YUKARI-AŞAĞI BİLDİRİM VERİLİR.
- BU ŞEKİLDE MOTORUN HAFIZASI SİLİNMİŞ OLUR.

WORKING INSTRUCTIONS FOR 70 SERIES GUILLOTINE MOTOR READING AND DELETING THE MOTOR WITH WHITEPLUS RECEIVER READING PROCESS:

- FIRSTLY, ELECTRICITY SHOULD BE GIVEN TO THE MOTOR WHICH IS INSTALLED.
- IN ORDER TO CODE THE REMOTE CONTROL TO THE MOTOR:
- THE TOP AND BOTTOM KEY OF THE CONTROL SHOULD BE PRESSED AT THE SAME TIME.
- MOTOR WILL PROVIDE NOTIFICATION WITH UP AND DOWN MOVEMENTS.
- THEN THE DIRECTION OF THE MOTOR SHOULD BE CHECKED.
- FOR THIS OPERATION, PRESS ONCE TO THE BUTTOM BUTTON OF THE CONTROL.
- IF THE GUILLOTINE IS MOVING DOWN, THE PROCESS IS CORRECT.
- THEN, THE TOP AND BOTTOM KEY OF THE CONTROL SHOULD BE PRESSED AT THE SAME TIME.
- IF THE FEEDBACK COMES UP AND DOWN FROM THE MOTOR, IT CAN BE UNDERSTOOD THAT THE MOTOR TAKES THE DIRECTION TO MEMORY.

IF THE DIRECTION IS REVERSE:

- THE CENTER BUTTON OF THE CONTROL SHOULD BE PRESSED.
- MOTOR WILL PROVIDE NOTIFICATION WITH UP AND DOWN MOVEMENTS.
- THE DIRECTION OF THE ENGINE CHANGES.
- LATER, THE LOWER AND UPPER SWITCH SETTINGS SHOULD BE SET UP.
- FIRSTLY, BEGIN FROM THE LOWER SWITCH.
- THE LOWER BUTTON OF THE REMOTE CONTROL SHOULD BE HELD DOWN FOR THE LOWER SWITCH.
- GUILLOTINE IS LOWERED TO THE DESIRED LEVEL.
- BY HOLDING DOWN THE MIDDLE BUTTON OF THE CONTROL, THE LOWER LIMIT IS MEMORIZED.
- MEANWHILE, THE MOTOR GIVES UP AND DOWN FEEDBACK.
- THE UPPER BUTTON OF THE CONTROL SHOULD BE HELD DOWN FOR THE UPPER SWITCH.
- SHUTTERS ARE INCREASED TO THE DESIRED LEVEL.
- BY HOLDING DOWN THE MIDDLE BUTTON OF THE CONTROL, THE UPPER LIMIT IS MEMORIZED.
- MEANWHILE, THE MOTOR GIVES UP AND DOWN TWICE FEEDBACK.
- READY TO USE WITHOUT BLINDS.

DELETING PROCESS:

- ELECTRICITY SHOULD BE CUT OFF, WAITING FOR 10 SECONDS.
- THEN THE ELECTRICITY IS RE-APPLIED.
- THE UPPER-LOWER AND MIDDLE KEYS OF THE CONTROL ARE PRESSED AT THE SAME TIME.
- THE MOTOR GIVES UP-DOWN FEEDBACK.
- THEN THE PROGRAM BUTTON ON THE BACK OF THE CONTROLLER SHOULD BE HELD DOWN.
- THE MOTOR GIVES UP AND DOWN NOTIFICATION IN FIRST.
- IT SHOULD BE WAITED BY CONTINUING TO PRESSING THE BUTTON.
- IT GIVES SECOND UP-DOWN NOTIFICATION AFTER ABOUT 7 SECONDS.
- BY THIS WAY, THE MEMORY OF THE MOTOR HAVE BEEN ERASED.

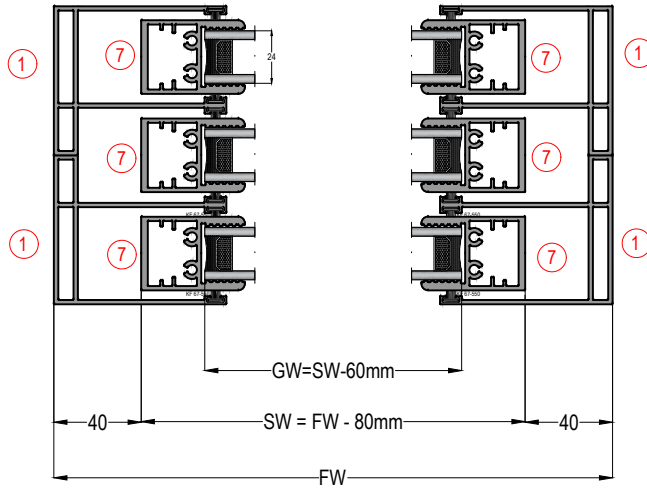

NOT: MAX KASA ENİ 4500mm, MAX KASA YÜKSEKLİĞİ 3000mm
MAX FRAME WITDH 4500mm, MAX FRAME HEIGHT 3000mm

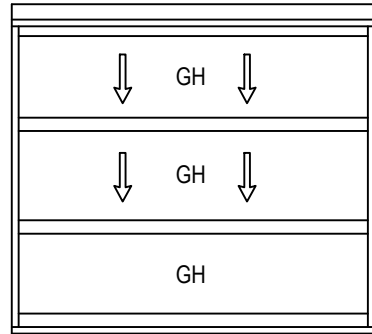

24MM CAM KESİM ÖLÇÜLERİ / 24MM GLASS CUTTING SIZES		
KOD / Code	TANIMI / Description	KESİM ÖLÇÜSÜ / Cutting Dimensions
GW	CAM GENİŞLİK / Sash Glass Width	SW - 60mm
GH	KANAT CAM YÜKSEKLİK / Sash Glass Height	SH - 60mm

(Kanat Geniřliđi / Sash width) SW = FW - 80mm
(Kanat Yüksekliđi / Sash Height) SH = (FH - 62.2mm) / 3

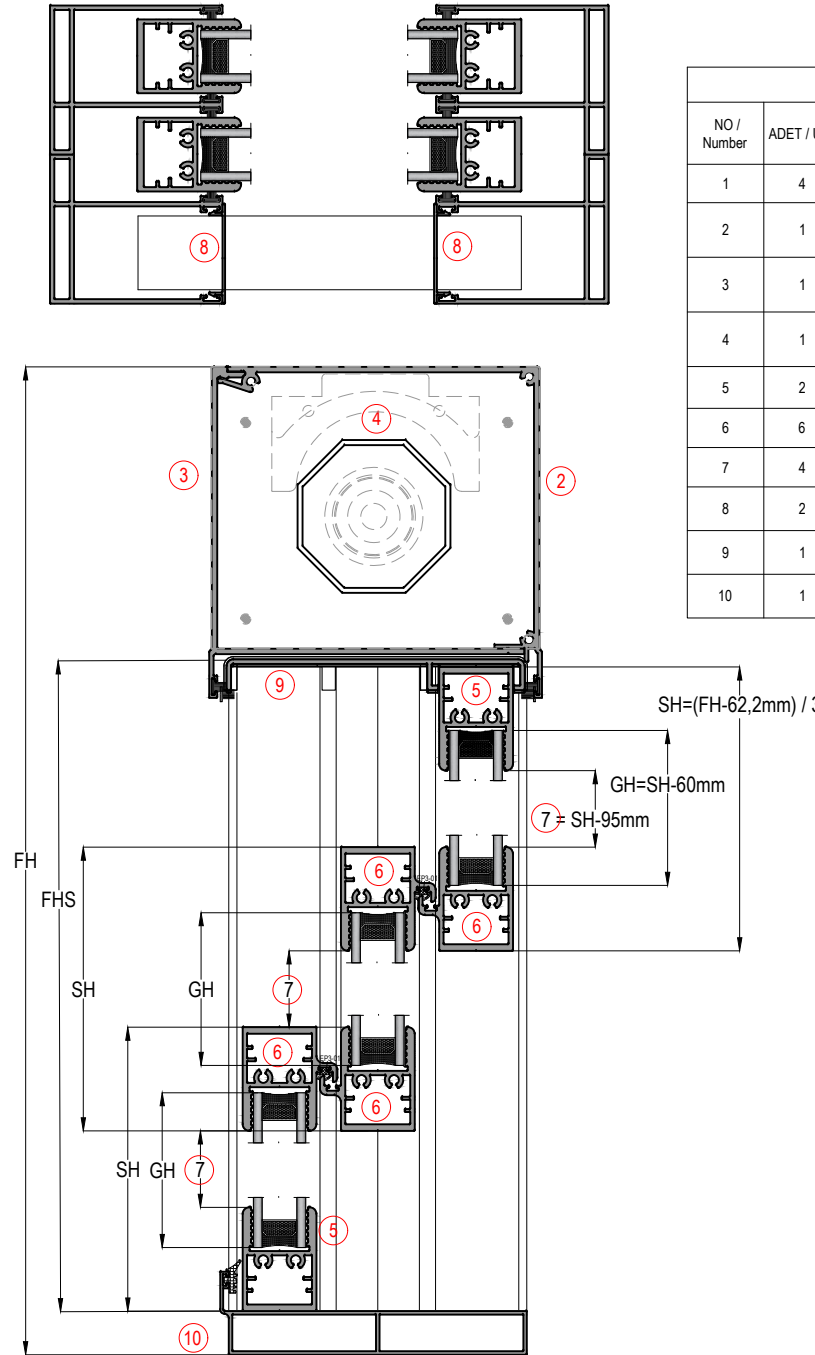

KESİM ÖLÇÜSÜ VE AKSESUAR LİSTESİ CUTTING SIZES AND ACCESORIES

PROFİLLER / PROFILES					
NO / Number	ADET / Unit	KOD / Code	PROFİL ÇİZİMİ / Drawing	PROFİL TANIMI / Description	KESİM ÖLÇÜSÜ / Cutting Dimensions
1	4	G100T 01		YAN KASA RAY PROFİLİ / Vertical Frame Rail Profile	FHS = FH - 152mm
2	1	G100T 02 R		ÜST KASA MOTOR İÇ KAPAK PROFİLİ / Horizontal Top Frame Cover Motor Profile	FW - 6mm
3	1	G100T 03R		ÜST KASA MOTOR DIŞ KAPAK PROFİLİ / Horizontal Top Frame Cover Motor Profile	FW - 6mm
4	1	G100 A12		MOTOR BORU PROFİLİ / Horizontal Motor Profile	FW - 40mm
5	2	G100T 11		ALT ve ÜST YATAY KANAT PROFİLİ / Horizontal Sash Profile Top&Bottom	FW - 80mm
6	6	G100T 11		DÜŞEY KANAT PROFİLİ / Vertical Sash Profile	SH - 95mm
7	4	G100T 12		ARA YATAY KANAT PROFİLİ / Horizontal Sash Profile Middle	FW - 80mm
8	2	G100T 05		YAN ÇİTA PROFİLİ / Side Cover Profile	FHS - SH
9	1	G100T 04		KAPAK PROFİLİ / Cover Profile	FW - 175mm
10	1	G100T 06		ALT KASA PROFİLİ / Bottom Frame Profile	FW

AKSESUARLAR / ACCESSORIES				
MİKTAR / Unit	KOD / Code	PROFİL ÇİZİMİ / Drawing	PROFİL TANIMI / Description	
1 Adet / Pcs	G100-A1		120 LİK MOTOR / Motor	
* 1 Adet / Pcs	G100 - A2		TEKLI KUMANDA / Single Remote Control	
* 1 Adet / Pcs	G100 - A3		ÇOKLU KUMANDA / Multi Remote Control	
2 Adet / Pcs	G100T - A4		DIŞLI / Gear	
2 Adet / Pcs	G100T - A6		METAL ASKI ZİNCİRİ / Metal Chain	
1 Takım / Set	G100T - A1		MOTOR YAN SACI / Motor Side Cover	
2 Adet / Pcs	G100 - A11-1		ZİNCİR KORUYUCU / Chain Guide	
1 Adet / Pcs	G100 - A11-2		PLASTİK RULMAN YATAĐI / Roller Slot	
1 Adet / Pcs	G100 - A11-3		GIYOTIN TAMBUR BAŐI / Motor Provisions	
1 Adet / Pcs	G100 - A11-4		RULMAN / Roller	
2 Adet / Pcs	G100T-A2		ZİNCİR ASKI SACI / Hanging Part	
10 Adet / Pcs	G100T-A3		MONTAJ PARÇASI / Assembly Part	
1 Takım / Set	EM-G100-A4		G100T 04 YAN KAPAK / Cover For G100T 04	
((4X(FHS-SH))+ (4X(FHS-(2XSH))))	KF 67-550		FİRÇA FİTİL-5,5mm / Brush	
2XFW	KF 67-560		FİRÇA FİTİL-6,5mm / Brush	
2XSW	EP3-01		KANAT BİNİ FİTİLİ / Sash Gasket	
FW	EP1-01		İÇ FİTİLİ - 5mm / Inner Gasket	

* İKİ KUMANDADAN BİRİSİ SEÇİLEBİLİR
YOU CAN CHOOSE ONE OF THEM

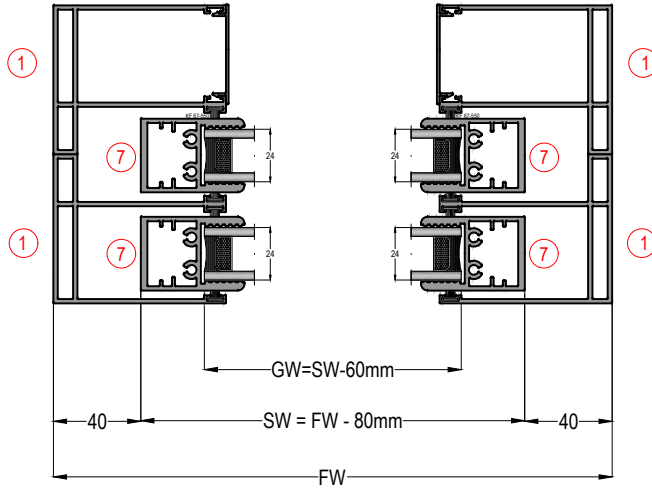

NOT: MAX KASA ENİ 4000mm, MAX KASA YÜKSEKLİĞİ 3000mm
MAX FRAME WITDH 4500mm, MAX FRAME HEIGHT 3000mm

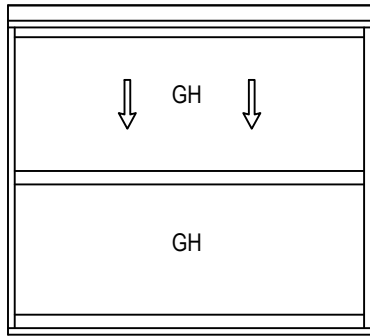

24MM CAM KESİM ÖLÇÜLERİ / 24MM GLASS CUTTING SIZES		
KOD / Code	TANIMI / Description	KESİM ÖLÇÜSÜ / Cutting Dimensions
GW	CAM GENİŞLİK / Sash Glass Width	SW - 60mm
GH	KANAT CAM YÜKSEKLİK / Sash Glass Height	SH - 60mm

(Kanat Geniřliđi / Sash width) SW = FW - 80mm
(Kanat Yüksekliđi / Sash Height) SH = (FH - 110mm) / 2

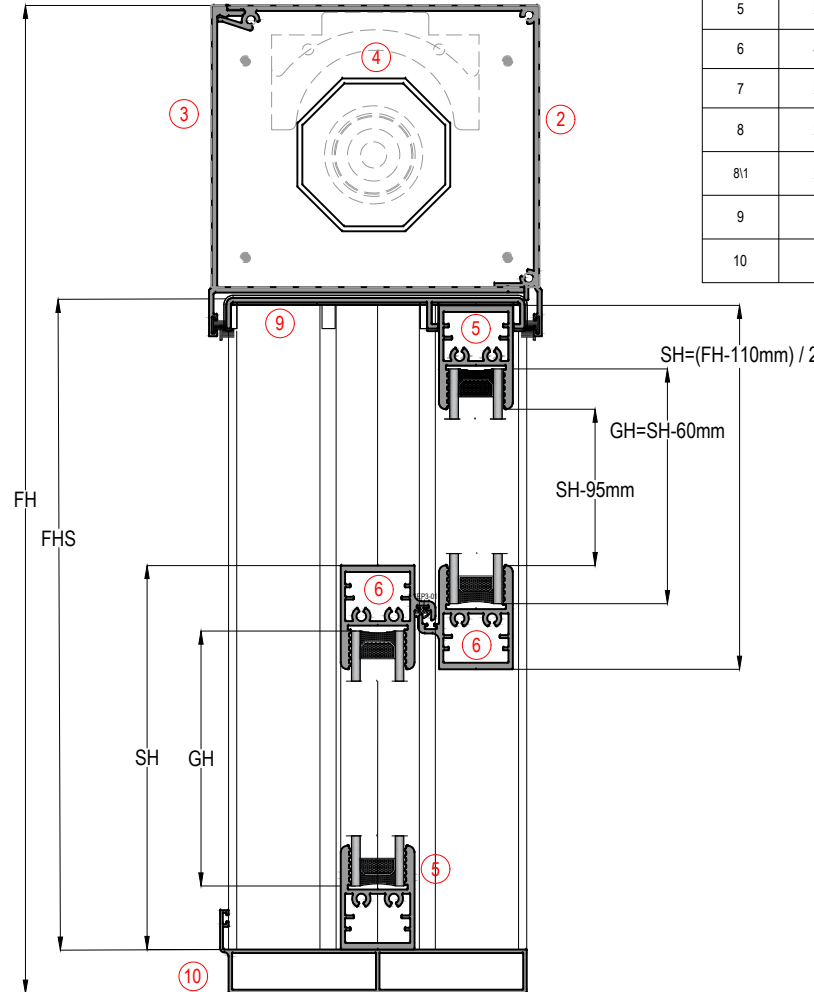
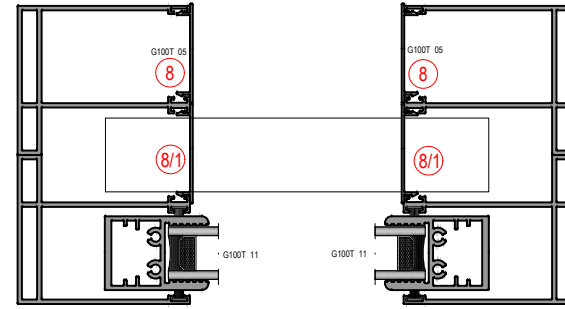

KESİM ÖLÇÜSÜ VE AKSESUAR LİSTESİ CUTTING SIZES AND ACCESORIES

PROFİLLER / PROFILES					
NO / Number	ADET / Unit	KOD / Code	PROFİL ÇİZİMİ / Drawing	PROFİL TANIMI / Description	KESİM ÖLÇÜSÜ / Cutting Dimensions
1	4	G100T 01		YAN KASA RAY PROFİLİ / Vertical Frame Rail Profile	FHS = FH - 152mm
2	1	G100T 02 R		ÜST KASA MOTOR İÇ KAPAK PROFİLİ / Horizontal Top Frame Cover Motor Profile	FW - 6mm
3	1	G100T 03 R		ÜST KASA MOTOR DIŐ KAPAK PROFİLİ / Horizontal Top Frame Cover Motor Profile	FW - 6mm
4	1	G100 A12		MOTOR BORU PROFİLİ / Horizontal Motor Profile	FW - 40mm
5	2	G100T 11		ALT ve ÜST YATAY KANAT PROFİLİ / Horizontal Sash Profile Top&Bottom	FW - 80mm
6	4	G100T 11		DÜŐEY KANAT PROFİLİ / Vertical Sash Profile	SH - 95mm
7	2	G100T 12		ARA YATAY KANAT PROFİLİ / Horizontal Sash Profile Middle	FW - 80mm
8	2	G100T 05		YAN ÇİTA PROFİLİ / Side Cover Profile	FHS
8/1	2	G100T 05		YAN ÇİTA PROFİLİ / Side Cover Profile	FHS - SH
9	1	G100T 04		KAPAK PROFİLİ / Cover Profile	FW - 175mm
10	1	G100T 06		ALT KASA PROFİLİ / Bottom Frame Profile	FW

AKSESUARLAR / ACCESSORIES			
MİKTAR / Unit	KOD / Code	PROFİL ÇİZİMİ / Drawing	PROFİL TANIMI / Description
1 Adet / Pcs	G100-A1		120 LİK MOTOR / Motor
* 1 Adet / Pcs	G100 - A2		TEKLI KUMANDA / Single Remote Control
* 1 Adet / Pcs	G100 - A3		ÇOKLU KUMANDA / Multi Remote Control
2 Adet / Pcs	G100T - A4		DİŐLİ / Gear
2 Adet / Pcs	G100T - A6		METAL ASKI ZİNCİRİ / Metal Chain
1 Takım / Set	G100T - A1		MOTOR YAN SACI / Motor Side Cover
2 Adet / Pcs	G100 - A11-1		ZİNCİR KORUYUCU / Chain Guide
1 Adet / Pcs	G100 - A11-2		PLASTİK RULMAN YATAĐI / Roller Slot
1 Adet / Pcs	G100 - A11-3		GIYOTIN TAMBUR BAŐI / Motor Provisions
1 Adet / Pcs	G100 - A11-4		RULMAN / Roller
2 Adet / Pcs	G100T-A2		ZİNCİR ASKI SACI / Hanging Part
6 Adet / Pcs	G100T-A3		MONTAJ PARÇASI / Assembly Part
1 Takım / Set	EM-G100-A4		G100T 04 YAN KAPAK / Cover For G100T 04
(4X(FHS-SH))+ (4XFHS)	KF 67-550		FİRÇA FİTİL-5,5mm / Brush
2XFW	KF 67-650		FİRÇA FİTİL-6,5mm / Brush
2XSW	EP3-01		KANAT BİNİ FİTİLİ / Sash Gasket
FW	EP1-01		İÇ FİTİLİ - 5mm / Inner Gasket

* İKİ KUMANDADAN BİRİŐİ SEÇİLEBİLİR
YOU CAN CHOOSE ONE OF THEM